



## Characterization of the influence of Amyloid $\beta$ (1-42) By Way of Modeling Synaptic Cleft with an RC Electronic Circuit

Mehmet Emin Tagluk <sup>1</sup>, Ibrahim Isik <sup>2,\*</sup>

<sup>1</sup> İnönü University, Electrical Electronics Engineering Department, Malatya, Turkey, ORCID iD: 0000-0001-7789-6376

<sup>2</sup> İnönü University, Electrical Electronics Engineering Department, Malatya, Turkey, ORCID iD: 0000-0003-1355-9420

### ARTICLE INFO

#### Article history:

Received 13.03.2020

Received in revised form

14.10.2020

Accepted 14.10.2020

Available online 13.01.2021

#### Keywords:

Alzheimer disease, Amyloid beta,  
Synaptic cleft

Doi: 10.24012/dumf.703270

### ABSTRACT

The research toward understanding the role of oligomeric amyloids in Alzheimer's disease (AD) has gained considerable attention in recent years. The information obtained in this direction showed that Amyloid Derived Diffusible Ligands (ADDLs) cause ambiguous ions movements across lipid bilayers in the plasma membrane and consequently alter its dielectric properties such as permeability. Nevertheless, how this amyloid protein selectively alters the permeability of the cell membrane has not been noted down because none of the specific receptors have been identified for ADDLs binding. As a result of the increase of cellular calcium level, local micromechanical properties of cells can change and thus induce reorganization of cytoskeletal structures that can cause neurodegenerative disorders such as AD. Therefore, in this study we have tried to specify the effect of alteration of permittivity and permeability of synaptic channel as modeling synaptic cleft by an RC circuit. By linking the electronic neuronal models that we have previously designed with the RC cleft model, when the information transferred from one neuron to another, the rate of error measured on the later neuron circuit with reference to the former one was determined with respect to the rate of change of R and C values individually. It was observed that C and R, and hence permeability of the synaptic channel do affect the communication error. It is concluded that a healthy synaptic channel conserves optimum resistivity and capacity levels at which the inter-neuronal signaling is achieved at a minimum error. These results could be linked to hypothesize that amyloids have a common feature in structuring channel-like concentrations which are supported by their electrical activity as well as the rate of permeability of Calcium like cautions.

## Introduction

Investigation of the role of oligomeric amyloids in Alzheimer's disease (AD) has attained substantial concentration in recent times. From the results obtained through the studies conducted in this trend, now it is believed that large amyloid oligomers in the form of diffusible ligands could be responsible for amyloid-induced cell toxicity [1]. Based on the data obtained through biophysical studies it has been deliberated that Amyloid Derived Diffusible Ligands (ADDLs) allow non-specified travel of ions across lipid bilayers (a membrane or zone of a membrane

composed of lipid molecules; usually phospholipids) [2]. This could probably happen via the thinning of plasma membrane and altering its dielectric properties such as permeability. However, it has not been spelled out how these amyloid proteins would specifically alter cell membrane permeability, and yet, there are none of the specific receptors that have been identified for ADDLs binding. Large scale oligomers have been mentioned to possibly alter the permeability of membrane not only through pathways of ion channels but also by way of shrinking the height of the dielectric barrier provided by the bilayer structure [2].

\* Corresponding author

Ibrahim, Isik

✉ e-mail: [ibrahim.isik@inonu.edu.tr](mailto:ibrahim.isik@inonu.edu.tr)

In some studies, globular shaped amyloids have been shown to induce toxic effect, by either non specific membrane leakage [3-4], or to develop ion channel like structures [5-8]. Interestingly, when the concentration of Amyloid beta, A $\beta$  (1-42) is low (typically around 0.22  $\mu$ m) some calcium waves have been observed, and these waves were increased with the increase of Amyloid beta concentration. These observations may be explained as that Amyloid beta forms calcium ion permeable channels in the plasma membrane. Through the intracellular calcium imaging studies, such as Lal et al., it has been shown that A $\beta$  (1-42) causes rapid cellular damage which does not seem to be triggered by an oxidative mechanism but undoubtedly initiated by means of calcium uptake by A $\beta$  [9]. As a consequence of the increase of cellular calcium level, the local micromechanical properties of cells can change [10] and thus induce reorganization of cytoskeletal structures that can cause neurodegenerative disorders/diseases such as AD [11].

From the evidence acquired through imaging of cellular structures by atomic force microscopy, it has been mentioned that A $\beta$  does not form fibres relevant to physiological concentrations, but does adapt to small oligomeric complexes by way of interaction with lipid bilayers found in the cellular porous medium [9]. In the study, it has been clearly shown that amyloids form oligomeric structures with a central pore that bear a resemblance to ion channels. This information is in parallel to the results obtained through electrophysiological studies made toward the formation of lipid bilayer channels that show a typical channel-like activity that exhibiting single channel conductance characteristics. This information is also supported by theoretical models [12-14] derived for amyloid channel-like structures.

In parallel to biophysical and imaging studies, through electrophysiological studies typical lipid bilayers on formation channels with signatures of channel conductance have been confirmed. Theoretical systematic models introduced for amyloid channel-like structures and Alphasynuclein based highly conductive ion channels [15] also do support these ion channel-like structures. It has been shown that Sialylation (Sialic acid) can cause a large depolarising shift in the activation mechanism [16] of voltage-gated

sodium channels and so altering the spiking threshold of the neuron without any variation in the patch-clamp recorded membrane voltage  $V_m$  in hippocampal pyramidal neurons [17].

Now, the issue is that could these small peptides, which can only partly infuse membrane, have the potential of formation of ionic amyloid channel models. The hypothesis made toward channel formation is convincing that amyloids have a common feature in structuring such channel-like concentrations that are supported by their electrical activity and the rate of permeability of Calcium like cations. Herein, in this study, we have tried to specify the effect of alteration of permittivity and/or permeability of synaptic channel by modeling synaptic channel/cleft with an RC circuit. By linking two electronic neuronal models that we have previously designed with the RC cleft model, when the information transferred from one neuron to another, the rate of error measured on the later neuron circuit with reference to the former one was determined with respect to the rate of change of R and C values individually. It was observed that C and R, and hence permeability of the synaptic channel do affect the communication error. It is concluded that a healthy synaptic channel conserves optimum resistivity and capacity levels at which the inter-neuronal signaling is achieved at a minimum error.

## Materials and Methods

From the literature, it is understood that Amyloid beta, A $\beta$ (1-42) eventually causes some sort of errors in the electro-chemical based communication of neuronal network, and this error is claimed to be the main reason behind AD [11, 18, 19].

In previous studies we have established an electronic circuit (model) that simulates the functional behaviour of a neuron (see Figure 1) [20-21-22]. In order to understand the role of the electrical properties of synaptic channel on the nano-scale communication managed between neurons we have simply characterized synaptic cleft with a parallel RC circuit. The RC channel model was aimed to relatively represent the permittivity and permeability of the channel. By way of altering the value of these circuit elements we try to understand how does the structure of synaptic cleft effect the electro-chemical

communication managed between synapses and/or neuronal cells. With the use of this model, it is aimed to understand how  $A\beta$  (1-42) peptide does change the electrical properties (mainly the permittivity and permeability of the medium which affects the impedance) of the circuit, and what sort of problems/errors do arise as a result of this change in the neuronal system.

For this, a series of experiments were conducted on the system where two neuronal electronic models were coupled via the RC synaptic channel model. With these experiments the impact of variation of complex impedance (resistance and capacitance) of the synaptic channel model on the communication error has been examined.

When the former neuron model is excited by a sinusoid wave like source, the membrane potential (spike train generated in response to the excitation) on both former and later neuron models were measured. The error that does arise in the impulse train measured on the membrane of the second neuron (the output of the later circuit) is calculated as given in Equation (1). This error is a spectral error that ultimately shows the rate of missing impulses and uneven delays that are considered to cause misinformation translation between neuronal cells.

$$error = \frac{1}{N} \sum_{n=1}^N \frac{1}{M} \left( \sum_{m=1}^M \left( \frac{f_{im} - f_{om}}{f_{im}} \right)^2 \right), \quad (1)$$

where,  $f_{im}$  is the instantaneous frequency of the spikes measured at the output of the former circuit calculated as  $f_{im} = 1/T_{im}$ ,  $f_{om}$  is the frequency of the spikes measured at the output of the later circuit calculated as  $f_{om} = 1/T_{om}$ .

$T$  is the time course measured between two successive impulsive peaks.  $M$  is the number of samples within each bin or window and  $N$  is the number of windows (bins) set over the signal.

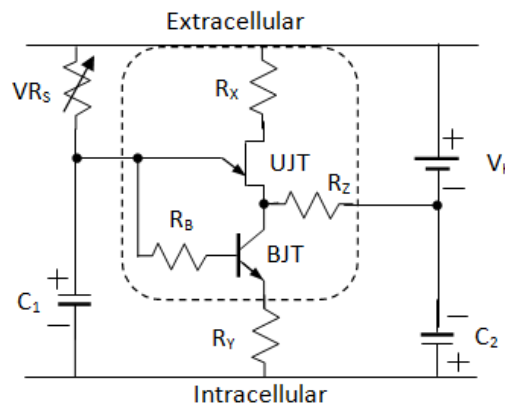

Figure 1. Electronic model of a segment of the membrane of a neuron, where all the information related to the circuit is explained [20, 21]

### Results

The results of experiments conducted on the neuronal electronic models coupled via the RC synaptic channel model showed that the impedance of the synaptic channel has an effect on the cellular communication error. It is shown that with the rate of change of  $A\beta$  (1-42) in the channel and cellular medium the ionic permittivity and permeability change and hence the impedance of synaptic channel (RC model) changes.

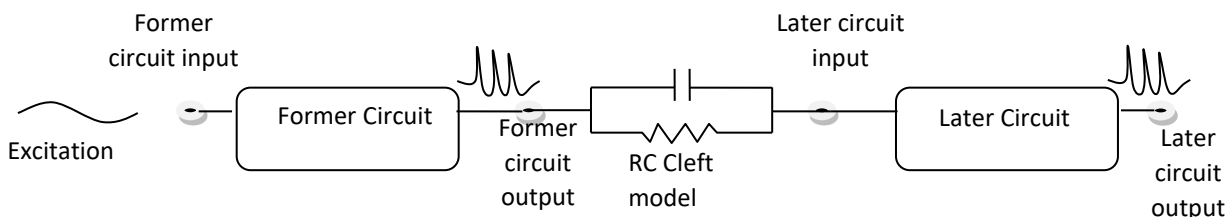

Figure 2. The schematic representation of the synaptic link between two neuronal cells (Electronic models)

The results also showed that, with the alteration of the RC values of channel model some errors arise in the cellular communication channel. As shown in Figure 3, while the output of former neuron (output1) comes up with a spike train characteristics fine-tuned with the input excitation, the later one, however, comes up with some deviations (output2) both in spike characteristics and temporal delays and/or missing spikes that cause fluctuations in the instantaneous frequency of the signal, as a kind of error. Therefore, in this sense, the error rate was measured in terms of instantaneous frequencies of the pulse trains occurred on both the former and the later neuronal electronic models, with respect to rate of change of the channel components, as given in Equation 1. Figure 4 and 5, respectively, show that as the values of R and/or C used in modelling synaptic channel increases the level of error first decreases up to a certain level, and then increases. The values of the R and C that give rise to a minimum rate of error can be said as the optimum channel parameters. As a common rule, it is known that increasing the permittivity of the dielectric between two current carrying conductor plates increases the capacitance per unit area and also decreases the impedance per unit area which in turn decreases the velocity of propagation of electrical current. On the contrary, increasing the permeability of the dielectric between the conductor plates increases the inductance per unit area, increases the impedance and so decreases the velocity of propagation. Since  $A\beta$  (1-42) is considered to alter the permittivity and permeability of the cellular medium, this should lead to a change of impedance, capacitance and inductance of the cellular medium as well as of the synaptic channel. As mentioned, the rate of change in impedance cause a chance in the velocity of propagation and consequently this comes up with cellular communication error.

**Discussion**

In this particular work we have investigated the possible role of  $A\beta$  (1-42) on the synaptic communication channel in terms of error measured at the later circuit model, when two electronic neuron models are connected in serial. This work is not aimed to cope with the cell

toxicity mentioned as caused by diffusible Amyloid oligomers [1], but aimed to somehow

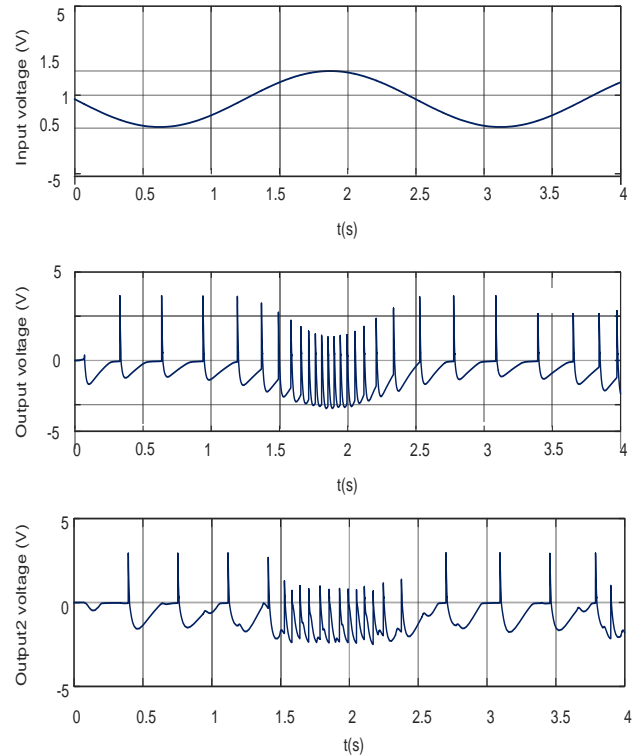

Figure 3. The waveforms (spike trains) measured at the output of the former (output1) and later (output2) circuits as the model of the synaptic cleft

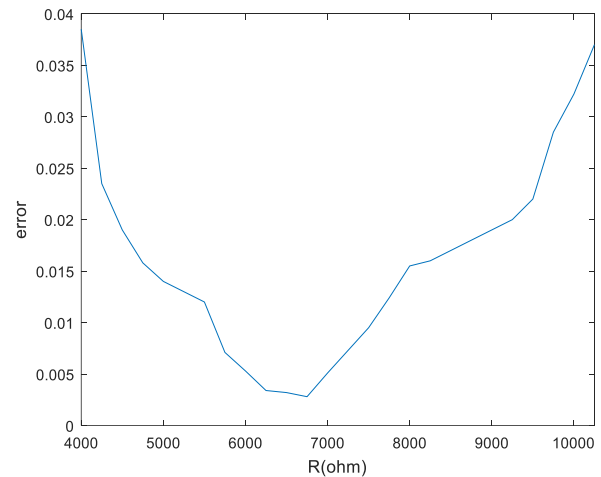

Figure 4. The rate of change of error with respect to the rate of change of Resistance of cleft medium at the Later circuit's output when the cleft's medium Capacitor is kept at  $C=1\mu F$

reveal the role of alteration of the permeability of plasma membrane with the damage of cellular

assembly mainly caused by ADDLs [9] in the format of membrane narrowing and/or reducing

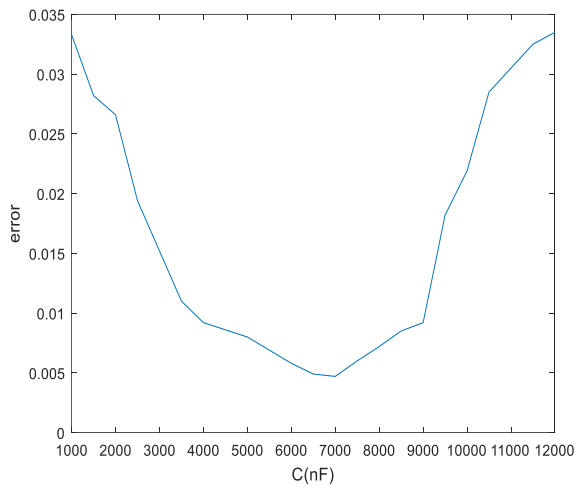

Figure 5. The rate of change of error with respect to the rate of change of Capacitance of cleft medium at the Later circuit's output when cleft's medium Resistance is kept at  $R=5\text{ K}\Omega$

the height of the dielectric barrier provided by the bilayer structure [2]. The work may also explore the role of development of  $\text{Ca}^{2+}$ -permeable ion channel like structures mentioned in [5-8] that cause an increase in cellular calcium level which might alter the local micromechanical properties of the cell [10] that consequently cause neurodegenerative disorders such as AD [11].

From the results we obtained it is proven that the information configured with an electrical signal that is propagating throughout the cellular network deforms in accordance with the variation of both resistance and capacitance of the medium derived from characteristic permittivity and permeability of the medium. In this work we showed the error resulted in the second neuron on the neuronal chain. We also analyzed the error rate at the output of third and fourth neurons subsequently connected to the second one as a kind of neuronal chain. When electrical information transmitted from one neuron to another, we observed that the highest error caused by the channel between first and second neuron. This can be explained as that, while the first neuron was excited with a pure sinusoidal waveform the second one was consequently excited by a pulse train. That is why the error at the output of the second neuron was so high. However, the subsequent neurons were excited

with pulse trains almost synchronized with the one at the output of second neuron. Since all of the neurons set in the chain were having the same characteristics and excited with similar pulse trains (one excites the other) the error arisen in the channel between them were not found so much high.

In Figure 4 it is seen that the signaling error first reduces to a minimum level and then increases with the increase of synaptic channel resistivity. In Figure 5 it is seen that the signaling error, as in the case of resistivity, also reduces to a minimum level and then increases with the increase of synaptic channel capacity. This means that a healthy synaptic channel conserves optimum resistivity and capacity levels at which the inter-neuronal signaling is achieved at a minimum error. This results prove that the permeability of the ionic channel has an effect on the signalling (information exchange) error which could be interrelated to the hypothesizes that amyloids have a common feature in structuring channel-like concentrations that are supported by their electrical activity and permeability of Calcium like cautions [12-14].

As can be seen from Figure 3 some of the spikes measured at the output of the later circuit are delayed or shifted compared to the ones measured at the output of the former circuit. This shift can also be linked to the assumption that Sialylation (Sialic acid) could cause a large depolarising shift in the activation curve [15] of voltage-gated sodium channels which consequently alter the spiking threshold of the neuron without any alteration in the patch-clamp recorded membrane voltage  $V_m$  in hippocampal pyramidal neurons [16].

## Conclusions

In this study the effect of alteration of electric properties of synaptic cleft such as permittivity and permeability on the cellular communication was investigated based on modelling synaptic cleft with an RC circuit. It was observed that when the electrical information transferred from one neuron to another the rate of error measured on the later neuron circuit first decreases and then increases with respect to the change of RC values. Thus it can be concluded that inter-neuronal signalling can be achieved at a minimum error at a certain R and C values of the synaptic channel

which may be termed as the healthy synaptic impedance. This result in turn proves the effect of permeability of ionic channel on the data translation error that might be arisen from A $\beta$  (1-42) that structure channel-like concentrations.

**Acknowledgments:** This study is supported by the İnönü University Scientifics Researchers Project Department (BAP) under project ID: FDK-2019-1359.

## References

- Gong YS, Chang L, Viola KL, Lacor PN, Lambert MP, Finch CE, Krafft GA, Klein WL., "Alzheimer's disease-affected brain: Presence of oligomeric A beta ligands (ADDLs) suggests a molecular basis for reversible memory loss." *Proc Natl Acad Sci U S A* 2003;100:10417–10422. [PubMed: 12925731]].
- Sokolov Y, Ashot Kozak J, Kayed R, Chanturia A, Glabe CG, Hall JE., "Soluble amyloid oligomers increase bilayer conductance by altering dielectric structure." *J Gen Physiol* 2006;128:637–647. [PubMed: 17101816]].
- Green JD, Kreplak L, Goldsbury C, Blatter XL, Stolz M, Cooper GS, Seelig A, Kist-Ler J, Aebi U., "Atomic force microscopy reveals defects within mica supported lipid bilayers induced by the amyloidogenic human amylin peptide.", *J Mol Biol* 2004;342:877–887. [PubMed: 15342243].
- Kayed R, Sokolov Y, Edmonds B, MacIntire TM, Milton SC, Hall JE, Glabe CG., "Permeabilization of lipid bilayers is a common conformation-dependent activity of soluble amyloid oligomers in protein Misfolding diseases", *J Biol Chem.* 2004, 279(45):46363-6.
- Lin H, Bhatia R, Lal R. "Amyloid beta protein forms ion channels: implications for Alzheimer's disease pathophysiology". *Faseb J* 2001;15:2433–2444. [PubMed: 11689468].
- Lin H, Zhu YWJ, Lal R. "Amyloid beta protein (1–40) forms calcium-permeable, Zn<sup>2+</sup>-sensitive channel in reconstituted lipid vesicles". *Biochemistry* 1999;38:11189–11196. [PubMed: 10460176].
- Quist A, Doudevski I, Lin H, Azimova R, Ng D, Frangione B, Kagan B, Ghiso J, Lal R. "Amyloid ion channels: A common structural link for protein-misfolding disease". *Proc Natl Acad Sci U S A* 2005;102:10427–10432. [PubMed: 16020533].
- Arispe N. "Architecture of the Alzheimer's A beta P ion channel pore". *J Membr Biol* 2004;197:33–48. [PubMed: 15014916].
- Ratnesh Lal, Hai Lin, and Arjan P. Quist, "Amyloid beta ion channel: 3D structure and relevance to amyloid channel paradigm." *Biochim Biophys Acta.* 2007, 1768(8): 1966–1975. doi:10.1016/j.bbamem.2007.04.021.
- Thomas T, Thomas G, McLendon C, Sutton T, Mullan M. "Beta amyloid mediated vasoactivity and vascular endothelial damage." *Nature* 1996;380:168–171. [PubMed: 8600393].
- Mattson MP. "Cellular actions of beta-amyloid precursor protein and its soluble and fibrillogenic derivatives." *Physiol Rev* 1997;77:1081–1132. [PubMed: 9354812].
- Mobley DL, Cox DL, Singh RRP, Maddox MW, Longo ML. "Modeling amyloid beta-peptide insertion into lipid bilayers". *Biophys J* 2004;86:3585–3597. [PubMed: 15189856].
- Durell SR, Guy HR, Arispe N, Rojas E, Pollard HB. "Theoretical-Models of the Ion-Channel Structure of Amyloid Beta-Protein". *Biophys J* 1994;67:2137–2145. [PubMed: 7535109].
- Tsigelny IF, Bar-On P, Sharikov Y, Crews L, Hashimoto M, Miller MA, Keller SH, Platoshyn O, Yuan JXJ, Masliah E. "Dynamics of alpha synuclein aggregation and inhibition of pore-like oligomer development by beta synuclein". *FEBS J* 2007;274:1862–1877. [PubMed: 17381514].
- Zakharov SD, Hulleman JD, Dutseva EA, Antonenko YN, Rochet JC, Cramer WA, "Helical alpha-synuclein forms highly conductive ion channels" *Biochemistry.* 2007 Dec 18;46(50):14369-79. Epub 2007 Nov 22.
- Savtchenko, L. P., Korogod, S. M. & Rusakov, D. A. "Electrodifusion of synaptic

- receptors: a mechanism to modify synaptic efficacy?" *Synapse* 35, 26-38 (2000).
17. Isaev, D. et al. "Role of extracellular sialic acid in regulation of neuronal and network excitability in the rat hippocampus". *J Neurosci* 27, 11587-11594 (2007).
  18. [https://www.alz.org/national/documents/topicsheet\\_betaamyloid.pdf](https://www.alz.org/national/documents/topicsheet_betaamyloid.pdf) "Beta-amyloid and the amyloid hypothesis", Alzheimer association, 888-372-3900, Alz.org, TS-0039 Updated August 2019.
  19. Sara H. Mokhtar, Maha M. Bakhuraysah, David S. Cram, and Steven Petratos, "The Beta-Amyloid Protein of Alzheimer's Disease: Communication Breakdown by Modifying the Neuronal Cytoskeleton", Hindawi Publishing Corporation International Journal of Alzheimer's Disease 2013, <http://dx.doi.org/10.1155/2013/910502>.
  20. M. E. Tagluk, "A New Dynamic Electronic Model of Neuron's Membrane", *Anatolian Journal of Computer Sciences*, Volume 3, Issue 1, 2018, Page 1-6.
  21. M Emin Tagluk, Ibrahim Isik, "Communication in nano devices: Electronic based biophysical model of a neuron" *Nano Communication Networks*, Vol 19, pp 134-147, 2019.
  22. E. Isik, I. Isik, M. E Tagluk, "Effect of A $\beta$  on the Probability of Molecule Reception in MCvD", *ICONDATA'20* June 25 - 28, 2020 in Istanbul, Turkey.