



# Design of an Automatic Item Pick-up System for Unmanned Aerial Vehicles

M. Emin Mumcuoğlu<sup>1</sup>, Ilgaz Yüksel<sup>1</sup> and Erdiñç Altuğ<sup>1\*</sup>

<sup>1</sup> İstanbul Technical University, Department of Mechanical Engineering, İnönü Cad. No:65, Beyoğlu, İstanbul.  
\*altuger@itu.edu.tr

Received: 21 February 2019

Accepted: 17 March 2020

DOI: 10.18466/cbayarfbe.529996

## Abstract

The interest of Unmanned Aerial Vehicles (UAVs) for the purpose of package delivery has increased significantly in recent years. However, the abilities of those vehicles are quite limited since the arms have not been designed considering the UAV geometry and the center of gravity (CG) changes. Usual approach taken by various researchers were to use a regular gripper or a robotic manipulator, which is not quite satisfactory for access. In this paper, a novel arm mechanism has been proposed to access objects near and under the UAV without risking any collision, with little rotor wash on objects and little change of UAV CG while enabling grip of variable shaped objects. The mechanism is based on a double four-bar linkage. Moreover, the gripper and the mechanism enable access to objects from locations below as well as next to UAV. With the help of the onboard controller and camera, the arm acts as an independent entity to identify the position of the part, catch it, and autonomously hold it. It is also possible to carry more than one object within the storage area. A flexible three-finger gripper has been designed to hold several different geometric shaped objects. The proposed arm and gripper designed, manufactured and installed on a UAV. Initial tests verify that it can identify and catch spherical, cylindrical, and box shaped pieces weighting up to 650 grams.

**Keywords:** Robotics arm design for UAV, Flexible Gripper, Four-bar mechanism.

## 1. Introduction

Unmanned aerial vehicles (UAVs), also known as drones, are among one of the most interesting research topic in the robotic field since last decade. These are aerial vehicles that can be operated remotely or can work autonomously. Nowadays they are being used for civilian, military and scientifically domains, for aerial photo shootings, agricultural tasks, drone races, commercial tasks, as well as just for fun. Non-military drone sales reach above 3 million in 2017 [1]. Quadrotors UAVs are the most popular subclass of UAVs. Thanks to their relatively simple mechanism and abilities of vertical take-off and landing, as well as agile maneuvering and hovering, it is accepted as an ideal candidate for search and rescue [2], mapping [3] and exploration [4].

Even though they are popular in many applications, they lack interacting with environment and objects. In previous literature, robotic manipulators or grippers are installed on UAVs for manipulation. In [5], a deployable manipulation system with 2 degrees of freedom (DOF) developed for a helicopter and in [6]

serial chain manipulator for a commercial quadrotor has been designed. Some research focused on increasing the limit of DOF and payload capacity [7]. Many of the designed manipulation mechanisms are connected to UAV from a single spot, which can easily cause undesired moment on the vehicle. Image-based control for aerial manipulation [8] is also relevant. UAVs are also used for disasters, such as the radiation monitoring in Fukushima, where nuclear leakage occurred in 2011 [9]. Picking and transporting objects could be valuable at these locations.

In the logistics sector, due to rapid urbanization, congestion and pollution increased, and logistics efficiency declined. A study conducted by Swiss Re predicts that the global urban population will increase by between 1.4 billion and 5 billion between 2011 and 2030. This trend will further increase delays in the flow of people and goods. In addition, research by McKinsey shows that e-commerce, has increased at an extraordinary level [10]. With all of this in mind, the widespread use of UAVs in the logistics industry can create great relief, especially within the city by taking a certain portion of the traffic from land to air (Fig. 1).

There are some prototypes of cargo carrying UAV systems of global cargo companies. Generally, objects are loaded to the UAV with a human or automatic system. UAVs with the ability to take parts from one place can only take one piece from the vertical direction. Moreover, if they have an arm, it is a general robotic manipulator designed for general robotic activities. It has not been designed by keeping in mind the UAV center of gravity change and accessibility.



**Figure 1.** UAVs to be used for the logistics sector [11].

USA based e-commerce company, Amazon, launched a project in 2013 that target delivery of a product within 30 minutes of the customer's order placement [12]. After the ordered product is placed in the box, it will be brought under the storage area under the UAV system with the rail system and the vehicle will be released for delivery. Amazon Prime Air, produced by Amazon, has a maximum weight of 25 kg and a carrying capacity of 2.26 kg. Amazon Prime Air predicts delivery at an average of 80.5 km per hour to destinations within 16 km range. In this context, the first experiment successfully in Cambridge, England on December 7, 2016.

DHL, an international logistics company, aims to deliver cargo with Parcelcopter unmanned aerial vehicle. Cargo loading to Parcelcopter is done manually by an operator [13]. DHL Parcelcopter has a carrying capacity of 1.2 kg. It has a 12 km range and planned speed of 43 km/h.

"Matternet M2" unmanned aerial vehicle, developed by Matternet company in partnership with Mercedes, is planned to be inserted in cargo vehicles. Therefore, when the cargo vehicle goes to the nearest delivery area, the range and charge limitations of the UAV will no longer be limited. In this system, the product to be delivered is placed under the UAV by the automatic shelf system [14]. Matternet M2's box size is 19x11x13 cm with a maximum weight of 2 kg and the maximum weight of the UAV is 11.5 kg. It is able to deliver at a distance of up to 20 km from the place where it is located with a flight speed of 36 km/h.

Another international cargo company, UPS, has built its own unmanned aerial vehicle for product distribution. UAV named, as "UPS HorseFly" will be loaded by the

operator into the cage below the UAV. UPS will also use commercial vehicles, such as those on Matternet M2, for cargo distribution [15]. UPS HorseFly's maximum speed is 80 km/h and the flight time is 30 minutes with a carrying capacity of 4.5 kg.

Unmanned aerial vehicle made by American-based Pepsi for commercial purposes has the ability to receive an object vertically [16]. This unmanned aerial vehicle, whose specifications are not shared, has designed to receive a ball.

Another important issue in design is the gripper. The ability to pick up objects other than standard boxes, such as spherical or cylindrical objects could be very useful. In literature, it has been seen that 3-finger holders provide a better grip on spherical objects than 2-finger systems.

The Robotiq Company [17] designed an articulated fingered gripper. The three fingers in Festo's product "Multichoice Gripper" are flexible, and provide a firm grip on different shaped objects [18]. Bosch's product "Apas Assistant" contains a 3-fingered holding system, which provides good grip on the cylindrical and box-shaped parts. In addition, hollow structures like cups or pipes can be hold [19]. In the patent "Gripper device for gripping objects" of FESTO Company in 2013, a spherical piece is held by a three-fingered mechanism [20].

Some researchers focus on vehicle routing side of delivery with drones [21, 22]. Some projects focused on UAV design and landing [23, 24].

In previous studies, UAVs are usually equipped with a simple robotic manipulators and simple grippers. It is quite easy to cause flight instabilities with a manipulator movement. This approach is not quite satisfactory since it changes the center of gravity of the vehicle, moreover does not enable easy access to objects near or under the UAV. In this paper, a novel mechanism for catching and holding variable shaped objects without considerable changing dynamic balance of the UAV, while enabling easy access to objects around it, has been proposed (Fig.2).

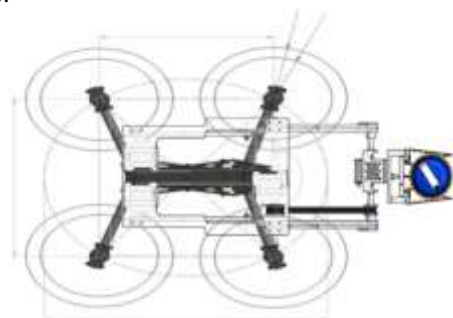

**Figure 2.** Top view of a robotic gripper and arm mechanism to be used on an UAV.

Since the object pick up and drop tasks require hovering, the type of UAV to be integrated in this paper was considered as a multi-rotor, quadrotor UAV.

The developed mechanism consisting of four-bar linkages mounted on the UAV and work cooperatively to avoid obnoxious moves. It will determine the location of an object by using image-processing techniques and will be capable of autonomously grasping multiple objects with different shapes. With this feature, the system can be easily used as a garbage collector (such as pet bottle, gum box) and keep it in its storage area. In addition, due to its ability to pick up objects it can be used in hard conditions/environments such as in a radiation environment that people cannot enter. The system also has a camera and on board vision processing to distinguish objects using QR or barcodes on them.

The mechanism designed in the project has the ability to receive objects from open shelves, such as the ones in pharmacies. The pick-up mechanism was designed to reach beyond the UAV propellers when it is going to make a horizontal pick up. It can also be used to pick up or deliver products to area under UAV, due to the rotating gripper mechanism.

The paper is organized as follows: Section 2 presents the design of the arm mechanism and adaptive gripper. In section 3, design of the mechanical and electronic of the arm, which can be implemented on a quadrotor, is described with applied computer vision method. Section 4 explains the autonomous grasp operation. In section 5 experiments are exhibited. Finally, in section 6 conclusions and future works are introduced.

## 2. Design of the Arm and the Adaptive Gripper

### 2.1. Design of the Arm Mechanism

The goal of the mechanism is to move the gripper to desired location in order to retrieve the object as needed. For indoor operation, a mini UAV is suitable, yet useful payload capacity of a mini UAV is very limited. Any additional weight not only limits useful payload capacity, but also useful flight time as well. Therefore, the arm mechanism has to be low weight, yet strong, and it should not move the center of gravity of the UAV beyond its stabilization limits. The load, which is at a considerable distance from the center of gravity of the drone during gripping, forces the vehicle to tilt, creating an additional torque to be balanced by the UAV. There are balancing systems on the drone against external factors such as wind, etc. However, designing the robotic gripper as physically balanced as possible will help those systems work properly. To limit CG and the torques due to the payload, the mechanism rests initially under the UAV. It moves forward when it needs to grasp an object. When it grasps an object, it carries it its initial position to limit its impact on UAV center of gravity.

For maneuverability and its ease of control, a mechanism consisting of four-bar linkages was selected. This approach is quite useful to extend and grasp the object and retrieve it towards to the center of the vehicle, therefore limit the center of gravity changes. The limits of the motion of the mechanism while it is holding an object is shown in Fig.3.

The other desired specification is the ability to grab the object even if there is some eccentricity in object location with respect to the UAV. To overcome this problem a mechanism consisting of two four-bar linkages was selected. With this design, the mechanism can grab objects with crosswise movements. The mechanism also enables slight yaw motions of the adaptive gripper to be placed at the end. In addition, a basket is put between the four bar linkages, enabling a secure storage area for multiple objects.

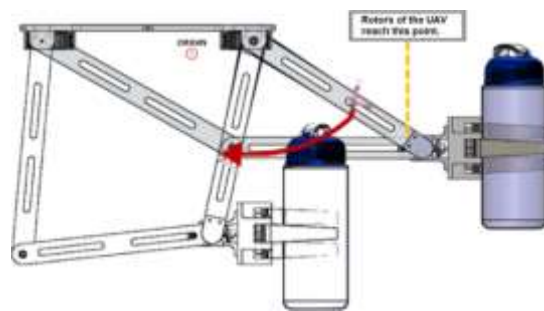

**Figure 3.** Motion limits of the mechanism

The target UAV's distance from its center to the tip of the rotors are 33 cm. The arm and the gripper should extend at least this far to grip and release any object. The selection of servomotors for the peak torque requirements, reachability analysis of the mechanism and cost were critical factors in design. Under strict torque requirements and weight limits, the size of the four-bar mechanisms were determined (Fig.4).



**Figure 4.** Mechanism at the position of grasping (up). Mechanism is at the position of balance (bottom).

## 2.2. Design of the Adaptive Gripper

The gripper is the most critical part of the system. It will grab objects horizontally as well as vertically. Various different shapes of objects e.g. spherical, cylindrical or rectangular shapes should be grasped. It should also hold this object safely, without dropping. The shape and size of some potential objects to be carried are listed in Table.1.

**Table.1** : Shape and Size of objects to be carried.

Shape	Size
Medication box	5x7,5x10 cm
A small box	7x12,5x12,5 cm
Bottle	Diameter of 8 cm x 28 cm
Water Bottle	Diameter of 5~7,5 cm x10 cm
Apple	Diameter of 5 cm

Taking into the size, weight and reliability criteria into consideration, a three-fingered adaptive retention mechanism was developed. The fingers have a flexible structure that allows the object to take its shape during the gripping movement. A screw mechanism that works with a continuous servo motor gives it the ability to grip and release.

A mechanical force analysis can determine the maximum load capacity of the gripper (Fig.5). The PowerHD AR3606HB servomotor can take 6 volts and a maximum of 1.2 amps. As the servo is squeezing the part, it will apply 0.4151 Nm. The maximum torque (M) applied on the M5 screw of pitch  $p$  of 0,8 mm with 0.15 ( $\mu_k$ ) friction can be gripped up to 8 cm.

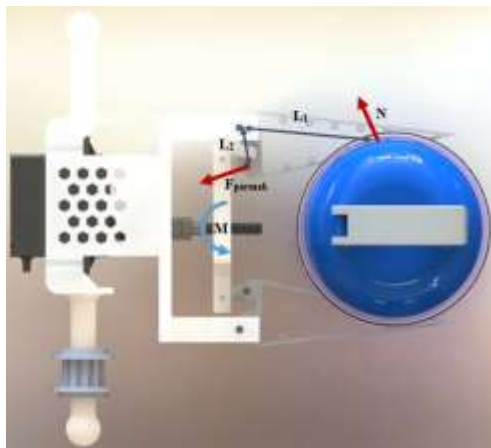

**Figure 5.** Design of the gripper rotator, and gripper moving systems.

Applied torque the gripper is;

$$T = F_{force} \left( \frac{d_2}{2} \tan(\varphi + p) + \mu_k \frac{d_k}{2} \right) \quad (2.1)$$

where  $\varphi$ ,  $p$  and  $d_k$  values are given as

$$\varphi = \tan^{-1} \frac{p}{\pi d} = 2.91^\circ$$

$$p = \tan^{-1} \frac{\mu_k}{\cos \frac{\alpha}{2}} = 8.66^\circ$$

$$d_k = 1.4d = 7mm.$$

The gripper force,  $F_{force}$ , can be calculated from Eqn.2.1 as 379.7 Newtons. The force per finger ( $F_{finger}$ ) can be calculated by dividing this number to 3. The finger force determined to be 126,6 Newtons. The gripper's fingers are made of polyurethane (with a coefficient of friction 0.2). The friction force can be calculated with Eqn.2.2, where  $g$  is the gravitational acceleration.

$$F_{friction} = mgk \quad (2.2)$$

In addition, there is a relation between finger force and friction force as

$$L_2 F_{friction} = 3L_1 F_{finger} \quad (2.3)$$

where  $L_1$  and  $L_2$  are given in Fig.5.

Combining these two equations lead us to calculate the maximum object weight that can be gripped without slipping as 2.97 kg.

$$m = \frac{3L_1 F_{friction}}{L_2 gk} \quad (2.4)$$

The designed system was produced with a 3D printer and mounted as shown in Fig.6.



**Figure 6.** a) Flexible finger, b) Manufactured gripper with three fingers.

## 2.3. Design of the Belt-Pulley System

A belt-pulley system was developed to rotate and hold the gripper, if needed (see pulley located on lower left side on Figure 5). To determine the torque transferred from the servo to the smaller pulley, gear ratio and belt efficiency are considered. The weight of the object and the gripper should be balanced with the transferred torque (Eqn.2.5).

$$T_{SmallPulley} > m_{gripper} gL_1 + m_{object} gL_2 \quad (2.5)$$

Under strict torque requirements and weight limits, the capacity of the gripper as well as the belt-pulley system

(to rotate the gripper) were designed (Fig.7). It was determined that for the particular choice of the servo mentioned previously, the upper limit of the weight of the object to be less than 746.63 grams. In addition, length of the belt for suitable operation is calculated.



**Figure 7.** Belt-pulley system.

One other issue to be investigated is the motion of the center of gravity (CG) as the manipulator grasps any object. Using SolidWorks program, CG location variation with respect to servo shaft angle are calculated (Table.2). It is verified that, for 700 grams of payload, the CG change is acceptable for the UAV.

**Table.2:** The center of gravity change.

Degree	x (mm.)	y (mm.)
30	203,8	-55,43
40	192,22	-64,29
50	171,19	-71,94
60	146,81	-78,03
70	119,81	-82,32
80	90,99	-84,61
90	61,2	-84,74

The mechanical design was finalized as presented in Fig.8.



**Figure 8.** Final design of the mechanism.

Table 3 lists the materials and the weights of each component of the arm. Total designed weight of the arm, gripper and the electronics is 1013 grams. A mini-

UAV that has a payload capacity of 2.5 kg can easily lift the mechanism and any object that weight up to 700 grams.

Assuming a 1 kg weight acting on the gripper, various analyses were made on ANSYS program (Fig.9) to determine the size, thickness, weight and strength of the mechanism. The four-bar mechanism and the shaft stress levels are calculated, and found to be low for failure. For the four-bar mechanism, the biggest stress appears at the connection points of the arm to the upper plate, as expected. The maximum stress determined to be 3.26 MPa is less than the stress limit of polycarbonate (63 MPa), which is the material choice for the arm. The safety factor, the ratio of the stress of the material to the calculated maximum stress value, is determined to be 19.2.

**Table.3 :** The weight of the materials.

Name	Quantity	Weight (g)
Finger	3	28,82
Gripper lower plate	1	61,99
Gripper connector	1	17,63
Shaft	1	41,63
Polycarbonate Bar	6	227,43
Upper plate	1	239,27
Pulley	1	11,21
Shaft-bar connection	2	13,21
Upper late connection	2	8,88
Servo Motor	4	160
Arduino	1	25
Raspberry Pi	1	45
Camera	1	15
Battery	1	88
Other Electronics	-	15
Other mechanical components	-	15
TOTAL		1013,11

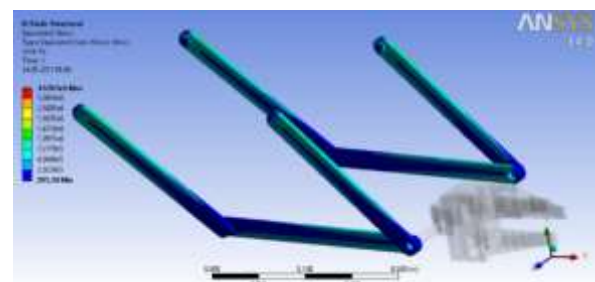

**Figure 9.** Design of the mechanism in ANSYS.

For the robotic gripper, the most critical part has been found as the gripper shaft. The maximum stress found to

be 12.9 MPa (Fig.10), appearing near the pulley. The shaft is made from ABS-M30, whose limit is 36 MPa. The safety factor was determined to be 2.79.

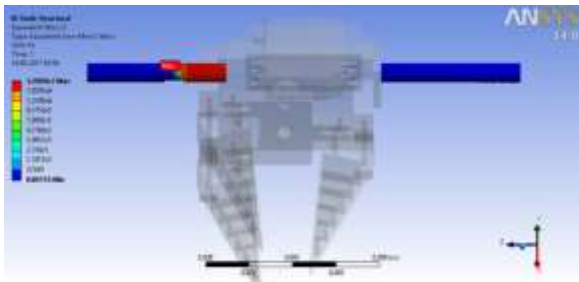
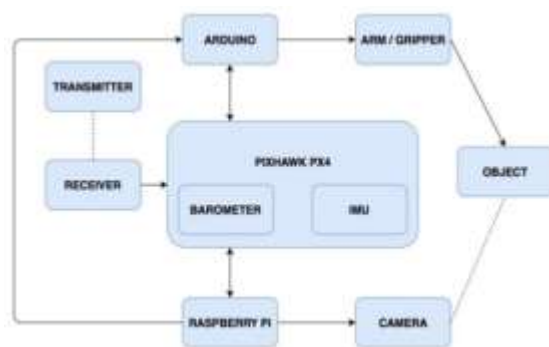

**Figure 10.** ANSYS analysis of the gripper.

Additional ANSYS analysis were made to verify that the servomotors could supply the required torque values as the arm and gripper are working. For the servomotors, the safety factor determined to be over 3.

#### 2.4. Control of the Manipulator Arms and the Gripper

The manipulator and gripper control intentionally separated from the UAV control to build a self-sufficient system. This enabled an autonomous system that can easily installed to any UAV. The block diagram of the developed system is shown in Fig.11. When there is an object with the desired QR or barcode tag (within reach), the arm will approach to grasp it. The UAV will wait in hover mode during the reaching and grasping operation. The arm actuation is done with four DC servomotors. The position control of these motors were managed by the Arduino Uno card with the help of the data received from the image processing.



**Figure 11.** Block diagram of the autonomous grab ability of the robotic gripper system.

The power required by the system is provided by an 1150 mAh Lithium-ion polymer battery running at 11.1V. This type of batteries is preferred in the UAV operations due to the high energy density and efficiency. In addition, to reduce the 11.1 V battery output value to 6V, which is the operating voltage of the servomotors, LM2596 adjustable voltage regulator,

which can carry up to 3 amperes, were used. In order to verify that an object was securely kept in the robot gripper, a current meter was used in the circuit. When the servomotor starts to compress object higher currents are observed. The controller monitors the current meter to prevent servomotor and/or object damage during grasping.

#### 2.5. Vision-based Object Detection and Grabbing

The goal of the vision-based detection and grabbing system is to locate a label and then direct the arm to grab it, independent of the UAV system. This requires tag detection in a scene, and estimation of its relative distance to the camera. Object detection and segmentation is the most important and fundamental task of computer vision. Even though it is still an open problem due to the variety and complexity of object classes and backgrounds, there is an easy and in some application acceptable solution for this problem which is using color based methods to detect and segment an object from an image.

For an autonomous grasping of an object, a color based computer vision algorithm has been developed on RaspberryPi by using a fish-eye lens camera and OpenCV library. To simplify the object detection process a label attached to it (Fig.12). This can be a QR code, a barcode or a special colored tag. A camera is positioned on UAV looking towards the arm extension area. The captured image frames by this camera are converted into HSV, since it is easier to work in HSV color space rather than RGB. At last step, we apply threshold with predefined value to discriminate the label from everything else in the environment and apply some morphological operations and Gaussian filter to reduce noise and have smooth output. The edge detection methods are used to calculate the area of the label. With pre-known measures of label, the position and distance of the object can be determined. Eventually the location and distance of the object are obtained in the 3D space.



**Figure 12.** Vision-based object detection algorithm.

The distance ( $d$ ) of the tag with respect to the camera is calculated from pixel data, and it is used to control the arm. Using this distance data, controller calculates suitable angle ( $\alpha$ ) of the mechanism to grasp the object (Fig.13), using Eqn.2.6.

$$\alpha = a \cos(1.73d^2 - 0.813) \quad (2.6)$$

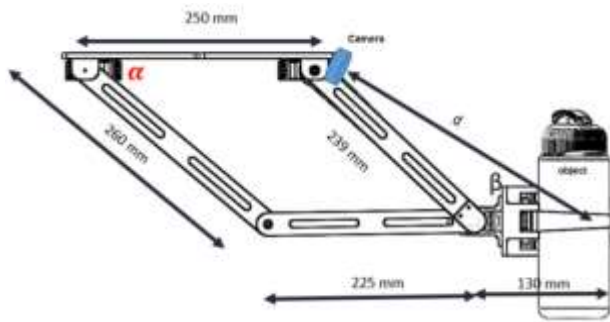
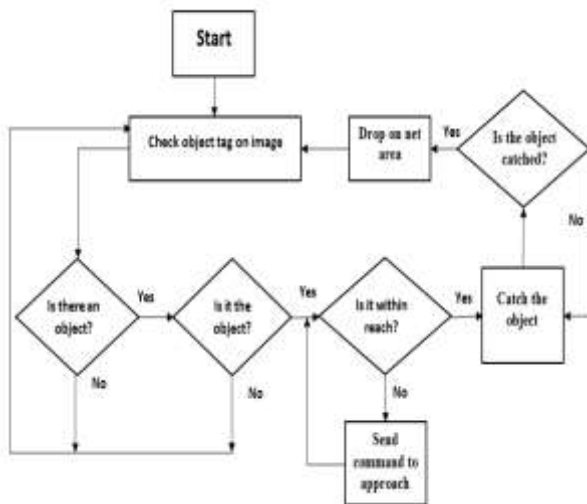

**Figure 13.** Geometry of the camera and the object on the UAV.

If the tag is at the center, the  $\alpha$  angle for both of the four-bar mechanisms will be same. If the object is slightly off the center,  $\alpha$  angle for both of the four-bar mechanisms should be different to compensate the offset of the tag, so that it can be grasped.

### 3. Object Detection and Gripping

The flow-chart of the operation of the system is shown in Fig.14.



**Figure 14.** Flowchart of the object grasping approach.

In operation, quadrotor UAV adjusts its position autonomously until the object is within reach of gripping mechanism. The arm is expected to grab the stationary object itself, independent of the UAV system. The system equipped with Pixhawk flight control card which has an internal barometer that measures the aerial pressure and sensors output used by Pixhawk to switch altitude hold mode. RaspberryPi uses the MAVLink protocol over a serial connection to communicate with Pixhawk. The position data is sent to the Pixhawk from RaspberryPi to adjust horizontal alignment of UAV according to object and the distance between vehicle and object is sent to Arduino UNO, which initiates autonomous grasping by operating the arm. Then the

four-bar linkage moves with the calculated angle that is directly related to the distance between the object and camera. After that, the adaptive gripper takes its position by belt and pulley mechanism. Gripper compresses the object until the current sensor in the gripper shows the critical current value, which means gripping process, is successful. Finally, the four-bar linkage turns into its initial balance position and release the object to basket. When the object is securely stored, the system is ready for another gripping. All these steps are coded with a locking system that avoids mechanism to skip processes without success.

### 4. Tests

The first step was to test the gripper's ability to grasp and hold various shaped and weighted objects. With its flexible fingers, the gripper can hold different objects firmly (Fig.15).



**Figure 15.** Object grasping test.

Table 4 presents grip test results, where it was observed if the UAV has enough payload carrying capacity, then the developed gripper mechanism can successfully grip and hold objects up to 650 grams.

**Table 4:** Designed gripper test results

Test Object No	Weight (grams)	Result
1	504	Successful
2	650	Successful
3	658	Unsuccessful

Second experiment was performed to test the ability to move the four-bar mechanism effectively to reach and grip objects.



**Figure 16.** Mechanism motion tests.

Finally, vision algorithm implemented on RaspberryPi was tested. In this test, whole system approached to the stationary test object, and the objects label were identified by the camera. When the distance is within acceptable limit, the mechanism was activated to grip the object by first approaching it with the four bar mechanism, and then grip it until the gripper servo reached a limiting current value.

When all of the subsystems are determined to be functional as desired, the whole system was assembled and mounted on a mini UAV system (Fig.17).



**Figure 17.** Manufactured mechanism, gripper and the electronic system installed on a UAV.

## 5. Conclusion

In this study, a self-sufficient, robotic arm with a gripper has been designed for UAV operations. Firstly, an adaptive flexible gripper is designed which can grasp various shaped objects. To improve grasping ability, inner surfaces of the retaining fingers were covered with a material with a higher coefficient of friction. It was seen that the system was quite successful in terms of strength with the analysis and observations made.

3D printer technology has been highly utilized to produce the ideal design. Especially the production of flexible gripper, this method was quite useful and easy. Embedded computer vision algorithm to determine object tag enabled the system to locate the object and grasp it if it is within reach, independent from the UAV controller.

This work assumed that the mechanism control and UAV control are two separate and distinct tasks. Combining the UAV control and arm control can

improve grasping of objects considerably. The UAV controller and arm controller can communicate about the location of the target, grip status, as well as other data. Similarly, the arm dynamics can be integrated on the UAV controller, which can lead to a more stable flight.

During the pick-up from horizontal position, the center of gravity should not change too much to disrupt the UAV balance. Another future work could be to develop a platform that has the center of gravity shifting ability. This can be done by extending another arm towards the opposite side of the grasping arm to balance the moment.

Flight tests were outside the scope of this paper. Our future work will include testing the system during flight and gripping items firstly with remote control of the UAV, and then with autonomous operation of the UAV.

## Acknowledgement

We would like to thank the Symmetrical Design for its support to the project. We also would like to thank Mr. Snyder, Eyüp Yüksel and Mr. Majid Mohammad Sadeghi for their support.

## Author's Contributions

**M. Emin Mumcuoğlu and İlğaz Yüksel:** Drafted and wrote the manuscript, performed the experiment and result analysis.

**Erdinç Altuğ:** Assisted in analytical analysis on the structure, supervised the experiment's progress, result interpretation and helped in manuscript preparation.

## Ethics

There are no ethical issues after the publication of this manuscript.

## References

1. Gartner Inc., Gartner says almost 3 million personal and commercial drones will be shipped in 2017. <http://www.gartner.com/newsroom/id/3602317> (accessed at 3.5.2017).
2. Michael, N, Shen, S, Mohta, K, Mulgaonkar, Y, Kumar, V, Nagatani, K, Tadokoro, S. 2012. Collaborative mapping of an earthquake-damaged building via ground and aerial robots. *Journal of Field Robotics*; 29 (5): 832-841.
3. Ozaslan T, Shen, S, Mulgaonkar, Y, Michael, N, Kumar, V. Inspection of Penstocks and Featureless Tunnel-like Environments Using Micro UAVs. In: Mejias L, Corke P, Roberts J. (eds) *Field and Service Robotics*, Springer Tracts in Advanced Robotics, vol 105, pp 123-136.
4. Tomic T, Schmid, K, Lutz, P, Domel, A, Kassecker, M, Mair, E, Burschka, D. 2012. Toward a Fully Autonomous UAV: Research





- Platform for Indoor and Outdoor Urban Search and Rescue. *IEEE Robotics & Automation Magazine*; 19 (3): 46-56.
5. Kucinski T. et al. Deployable Manipulator Technology with Application for UAVs. In: Sasiadek J (eds) *Aerospace Robotics II. GeoPlanet: Earth and Planetary Sciences*, Springer, Cham, 2015, pp 93-103.
  6. Orsag, M, Korpela, C, Oh, P. 2013. Modeling and Control of MM-UAV: Mobile Manipulating Unmanned Aerial Vehicle. *J Intell Robot Syst*; 69: 227-240.
  7. Fanni, M, Khalifa, A. 2017. A New 6-DOF Quadrotor Manipulation System: Design, Kinematics, Dynamics, and Control. *IEEE/ASME Transactions on Mechatronics*. Institute of Electrical and Electronics Engineers (IEEE). <https://doi.org/10.1109/tmech.2017.2681179>
  8. Mebarki, R., & Lippiello, V. 2014. Image-Based Control for Aerial Manipulation. *Asian Journal of Control*. Wiley-Blackwell. <https://doi.org/10.1002/asjc.887>
  9. International Atomic Energy. 2014. Monitoring radiation with drones. [Online]. [Accessed: 3 May 2017]. <https://www.iaea.org/newscenter/multimedia/podcasts/monitoring-radiation-drones>
  10. Kuckelhaus, M. 2014. Microdrones in logistics. <https://www.microdrones.com/en/applications/growth-markets/quadcopter-for-logistics/>. [Online]. [Accessed: 3 May 2017].
  11. Amazon Lays Out Plan for Drones to Navigate Skies. <https://www.wsj.com/articles/amazon-lays-out-plan-for-drones-to-navigate-skies-1438106902>. [Online]. [Accessed: 9 December 2018].
  12. Wikipedia. 2017. Amazon Prime Air. [Online]. [Accessed: 3 May 2017]. [https://en.wikipedia.org/wiki/Amazon\\_Prime\\_Air](https://en.wikipedia.org/wiki/Amazon_Prime_Air)
  13. DHL. 2014. DHL Parcelcopter. [Online]. [Accessed: 14 February 2019]. <https://discover.dhl.com/business/business-ethics/parcelcopter-drone-technology>
  14. Matternet. 2017. In action for public health: MatternetM2. [Online]. [Accessed: 3 May 2017]. <https://www.post.ch/-/media/post/ueber-uns/medienmitteilungen/2017/drohnen/spezifikationen-matternet-m2.pdf?la=en>
  15. Perez, S. 2017. 'UPS tests show delivery drones still need work'. [Online]. [Accessed: 3 May 2017]. <https://techcrunch.com/2017/02/21/ups-tests-show-delivery-drones-still-need-work/>
  16. Macleod, D. 2015. Pepsi Max Drone Football. [Online]. [Accessed: 3 May 2017]. <http://theinspirationroom.com/daily/2015/pepsi-max-drone-football/>
  17. Robotiq. 2017. Adaptive 2-finger robot gripper. [Online]. [Accessed: 3 May 2017]. <http://robotiq.com/products/adaptive-robot-gripper/>
  18. FESTO, 2014. Multichoicegripper. [https://www.festo.com/net/SupportPortal/Files/333986/Festo\\_MultiChoiceGripper\\_en.pdf](https://www.festo.com/net/SupportPortal/Files/333986/Festo_MultiChoiceGripper_en.pdf) [Online]. [Accessed: 3 May 2017].
  19. BOSCH. 2017. APAS Assistant. [Online]. [Accessed: 3 May 2017]. [http://www.bosch-apas.com/en/apas/produkte/assistant/apas\\_assistant\\_3.html](http://www.bosch-apas.com/en/apas/produkte/assistant/apas_assistant_3.html)
  20. FESTO AG & CO KG. 2014. Gripper device for gripping objects. European Patent, No: EP2735408 (A1), 2014.
  21. Dorling, Kevin, Jordan Heinrichs, Geoffrey G Messier, and Sebastian Magierowski. "Vehicle Routing Problems for Drone Delivery." *IEEE Transactions on Systems, Man, and Cybernetics: Systems* 47, no. 1 (2016): 70-85.
  22. Scott, Judy, and Carlton Scott. "Drone Delivery Models for Healthcare." Paper presented at the Proceedings of the 50th Hawaii international conference on system sciences, 2017.
  23. Köse O, and Oktay, T. "Non Simultaneous Morphing System Design for Quadrotors," *European Journal of Science and Technology*, vol.16, pp.577-588, 2019
  24. Ören, A, Koçyiğit, Y. "Unmanned Aerial Vehicles Landing Sequencing Modelling Via Fuzzy Logic / İnsansız Hava Araçları İniş Sıralamasının Bulanık Mantık Modellemesi". *Celal Bayar University Journal of Science*, 12, 2016.