

INTERCEPTOR DESIGN AND CONTROL FOR THE HIGH SPEED CRAFT

Ataol TUNÇER*, Gökhan Tansel TAYYAR* and Yalçın ÜNSAN*
* *Istanbul Technical University*

ABSTRACT

Constant trim by stern at high speeds is an important element which decreases the performance of the high speed craft. Interceptor is one of the solutions for this issue. The aim of this study is to analyze an interceptor mechanical design and to preview the electronic control options.

Keywords: Trim Tab, Interceptor, Automation, Control Systems, High Speed Crafts

1. Introduction

Achieving high speeds on water is a desirable but challenging ambition. Therefore different types of hulls were used to achieve desired speeds. Some of major types are as follows; Mono hull, Catamaran & Trimaran (Multi-Hulled Vessels), Hydrofoil Craft, Surface Effect Ship (SES) and Small Waterplane Area Twin Hull (SWATH). [1] Within this study mono hull high speed crafts will be the subject hull form.

2. Planing Mono Hulls

Planing mono hull forms broadly look like Figure 2.1 Planing Mono Hull Elements [2] and Figure 2.2 Sample Planing Mono Hull Forms [3].

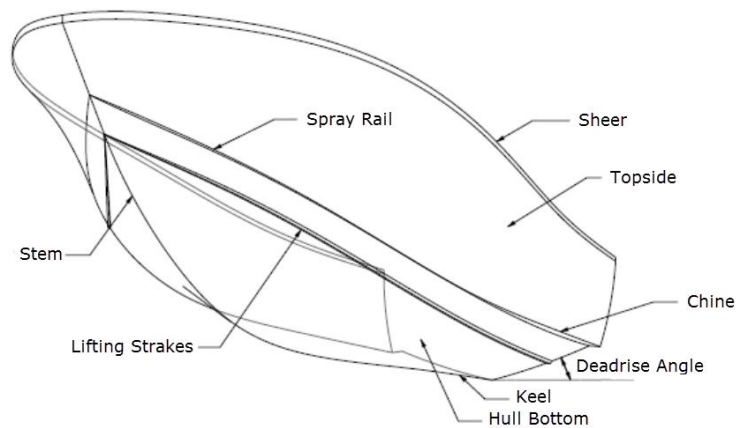

Figure 2.1 Planing Mono Hull Elements [2]

Chine is to ease planing for a high speed craft by creating a flat surface to allow a greater lift force. Lift force is essential to reach higher speeds with a mono hull craft, as it lifts the vessel upwards, thus decreasing the displacement volume. This hydrodynamic lift force replaces the

equivalent buoyant force supporting the vessel's weight during planing. [3] But the lift force is not only advantageous, since it mostly lifts the bow creating a trim angle by the stern.

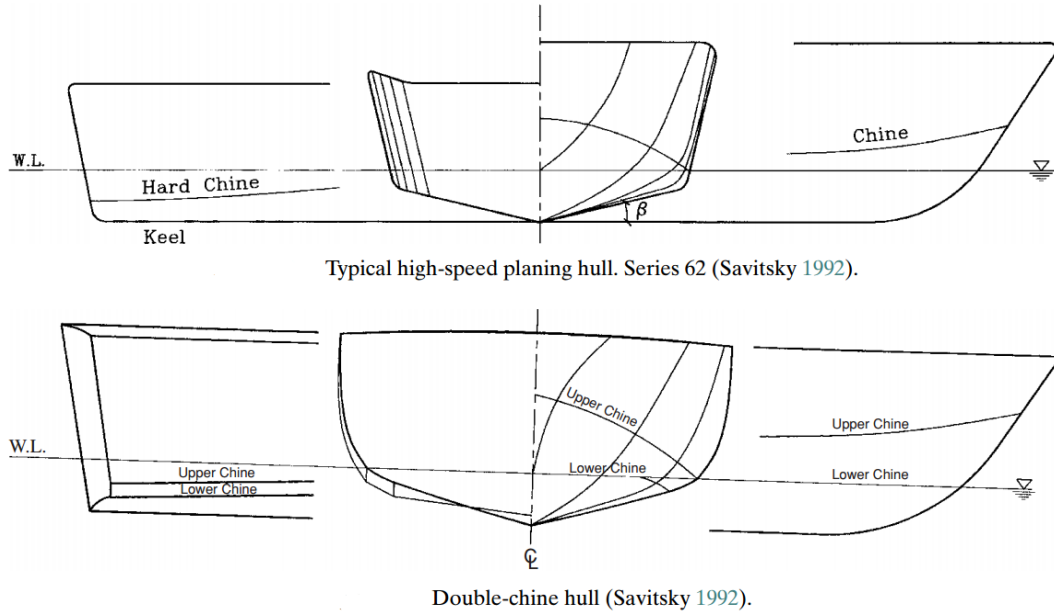

Figure 2.2 Sample Planing Mono Hull Forms [3]

Constant trim of the high speed crafts cause not taking the full advantage of the thruster since the propulsion will occur at a certain angle, not parallel to the water plane, as seen in Figure 2.3 Trim by Stern While Planing [4].

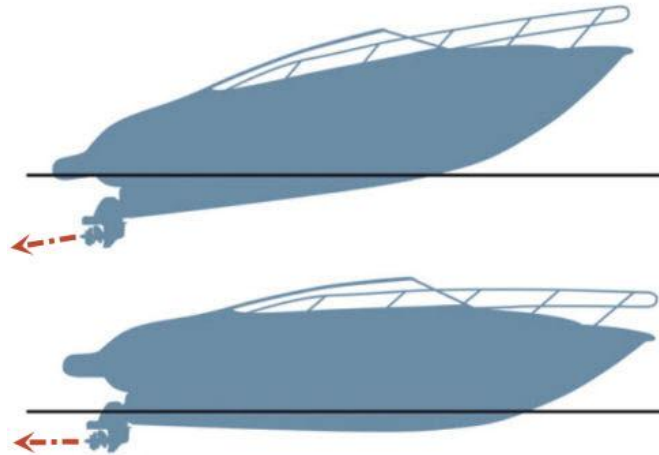

Figure 2.3 Trim by Stern While Planing [4]

3. Trim Tabs

Trim tab is a solution to aforementioned trim caused problem. Trim tabs basically eliminate the trim but also with a pair of trim tabs (one on port side one on starboard side), one can easily eliminate heel and yaw motions for a more comfortable ride. Trim tabs can be considered as motion stabilizers in a way, thus inventions and designs leading to trim tab goes back until late 1800s. First developments were in favor of stabilizing the roll and pitch motions, then specializing in high speed crafts lead to traditional and interceptor type trim tabs' invention.

3.1 History of Vessel Stabilizing Devices and Trim Tabs

First ship motion stabilizing devices were invented in late 1800s and early 1900s. Below inventions, shown in chronological order, project the development leading to trim tabs and eventually interceptors.

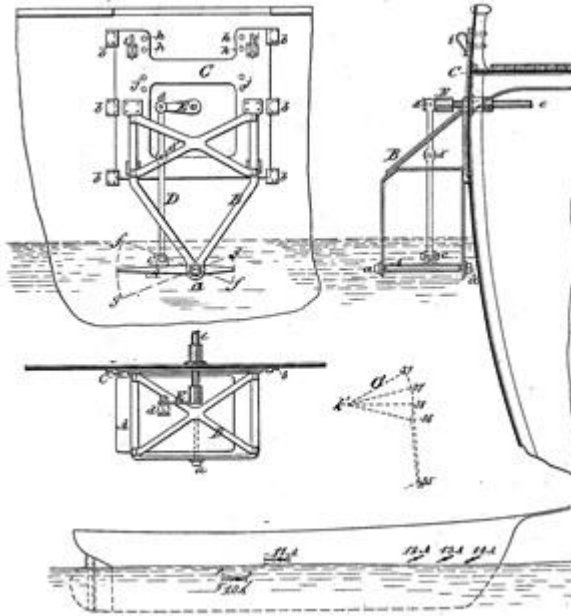

Figure 3.1 Apparatus for regulating the rolling and pitching of vessels [5]

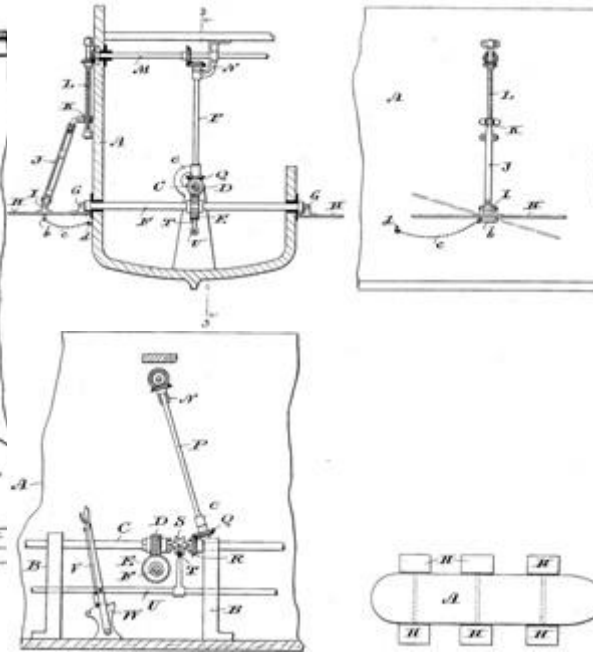

Figure 3.2 Adjustable fin for vessels [6]

First few vessel stabilizing extensions/devices were as shown in Figure 3.1 Apparatus for regulating the rolling and pitching of vessels [5] and Figure 3.2 Adjustable fin for vessels [6]. Then in the mid-1900s initial “trim tabs” were invented (Figure 3.3 Extension attachment for boats [7]). Although the first few inventions aimed the same objectives with their predecessors, such as stabilizing the vessel or decreasing the vibrational effects, they are practically similar to conventional trim tabs.

After moving the stabilizing extensions from side shell to the transom, different variations were invented (these inventions vary as different actuating methods or different plate types but fundamentally serve similar purposes). For example, same stabilizing purposes with pivotable hydrofoils were invented as seen in Figure 3.4 Boat having pivotable underwater hydrofoils [8].

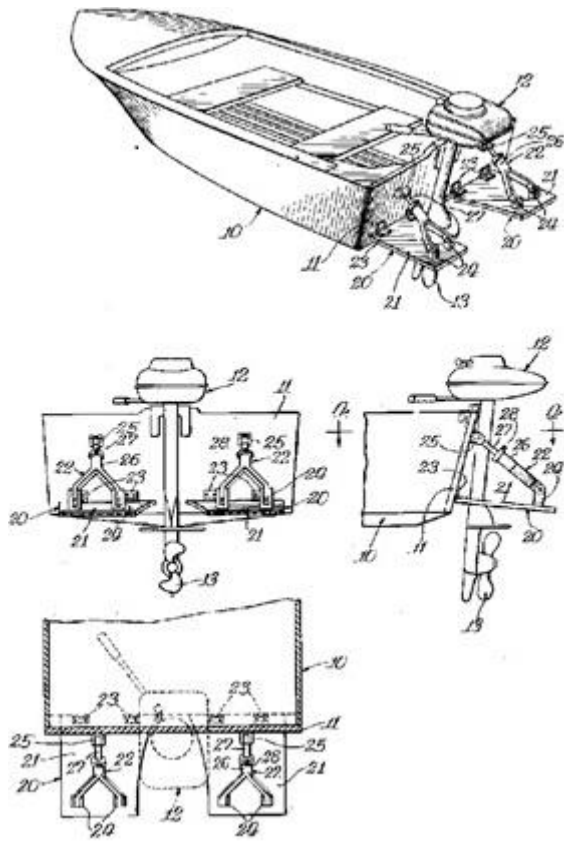

Figure 3.3 Extension attachment for boats [7]

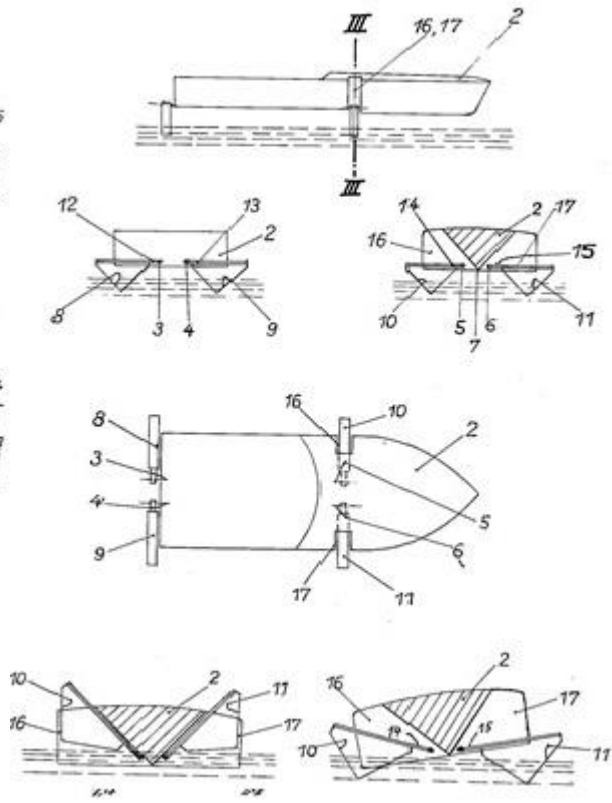
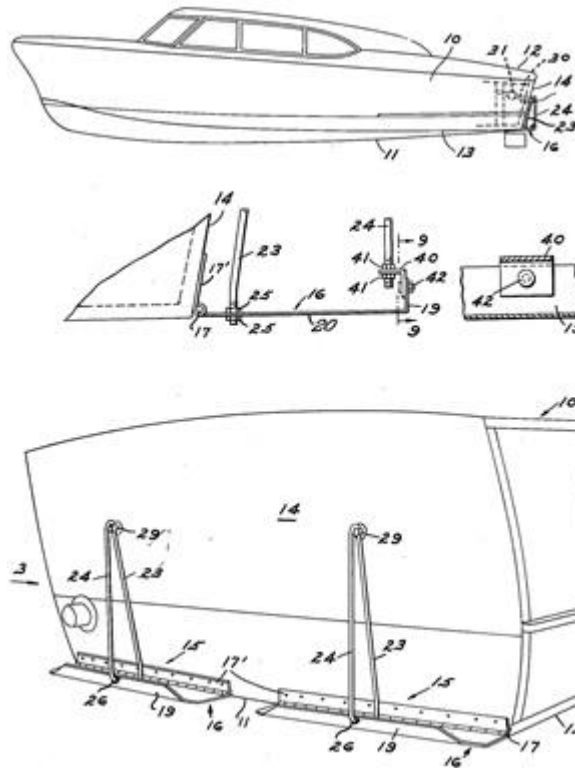

Figure 3.4 Boat having pivotable underwater hydrofoils [8]

First trim tabs (for high speed craft trim adjusting purposes) were invented in 1961-1962 (Publication dates). These inventions are as seen in Figure 3.5 Adjustable planing-floats for power



boats [10] and

Figure 3.6 Trim attachment for power boats [9]. Later on, due to the high drag forces and bulkiness of traditional trim tabs, interceptor trim tabs were invented as seen in Figure 3.7 Arrangement for dynamic control of running trim and list of a boat [11].

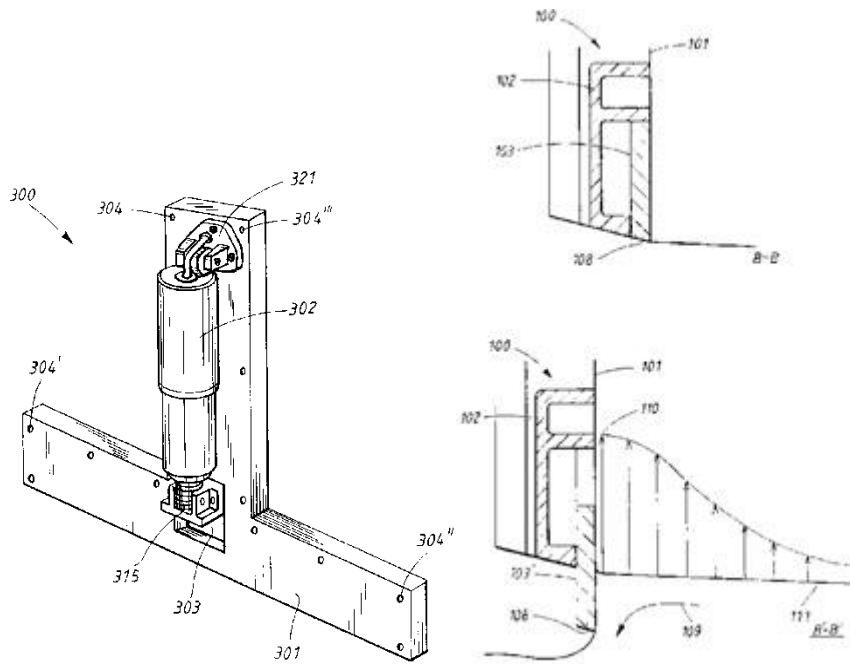

Figure 3.7 Arrangement for dynamic control of running trim and list of a boat [11]

3.2 Interceptors vs. Conventional Trim Tabs

Conventional trim tabs are basically flat plates that are flush and on the same plane with the bottom of the vessel. An actuator (or two) connects the tab plate to the transom, commonly diagonally. Interceptors are vertical plates (while conventional trim tabs are horizontal) actuated in a parallel vector.

Conventional trim tabs can be seen in Figure 3.8 Conventional Trim Tab [12] and interceptors can be seen in Figure 3.9 Interceptor [13].

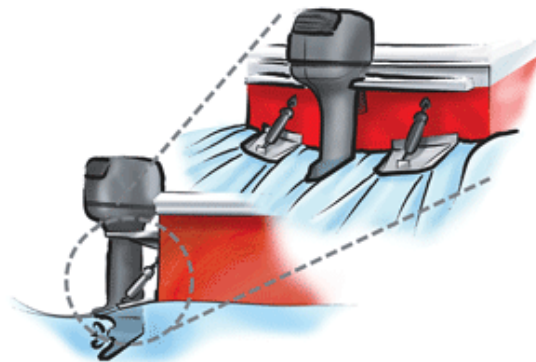

Figure 3.8 Conventional Trim Tab [12]

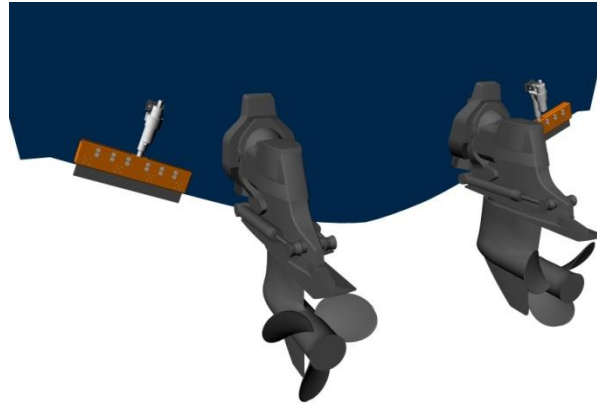

Figure 3.9 Interceptor [13]

Interceptors can be chosen over trim tabs due to many reasons. These reasons vary from low drag force to easy maintenance or from low cost to lightness. Interceptors are significantly lighter than trim tabs and minimizing the weight is essential for high speed crafts. [3]

Table 3.1 was provided for a better understanding of the comparison between trim tabs and interceptors.

Table 3.1 Comparison between Trim Tabs and Interceptors [14]

Parameter	Trim Tab	Interceptor
Maximum Lift Developed for Ride Control	Significantly Higher	Lower
Hull Resistance at Optimum Trim	Same	Same
Weight	Higher	Lower
Installation	Harder	Simpler
Cost	Higher	Lower
Maintenance	Harder	Simpler
Damage from Floating Objects	Minimal Risk	Higher Risk
Established User Base	Large	Smaller

Below, Figure 3.10 Drag force comparison [15] shows drag force comparison for both options.

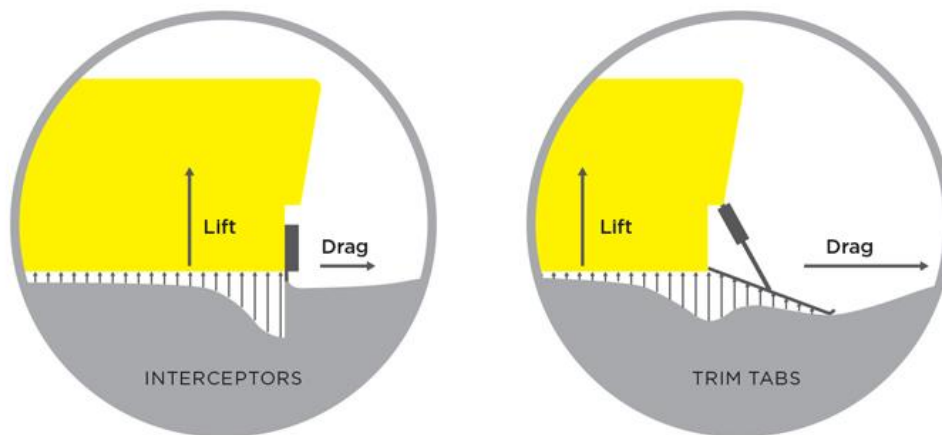

Figure 3.10 Drag force comparison [15]

4. Mechanical Design of an Interceptor

Mechanical design of an interceptor starts with designating the main components and breaking down these components to parts.

Main components are basically as follows (but may vary according to the design);

- Actuator (with linear or rotary actuating and could be pneumatic, hydraulic or electric driven)
- Interceptor blade (best preferred to be light weight, most likely aluminum or a stiff composite)
- Case or something similar to mount the interceptor to the hull and to embed the interceptor blade

4.1 Actuator

All displacement of the interceptor blade is provided by the actuator. Therefore actuator selection is important. Required criteria should be achieved with this selection, such as required force, stroke length and speed.

Minimum actuating force should be calculated.

$$F_L = \frac{1}{2} \times \rho \times v^2 \times A \times C_L \quad (4.1)$$

Lift force can be calculated according to the above formula (4.1).

$$F_f = \mu \times N \quad (4.2)$$

Friction force between the interceptor blade and the bearing can be calculated with the above formula (4.2). Minimum actuating force is equal to the calculated friction force.

Actuator should be selected according to designated force, stroke length that provides enough area for required lift force and desired stroke speed. Also either the actuator should meet IP67 criteria or there should be a watertight casing covering the actuator.

4.2 Interceptor Blade

Interceptors (or also trim tabs) are sized according to the lift required for the vessel. The required lift force has a direct effect on interceptor blade size and thereby the actuating force (as aforementioned). By the Formula 4.1 required area for the interceptor blade can be determined. Chord and span then will be designated according to limitations.

After designating the dimensions of the interceptor blade, the material and the thickness of the blade should be designated. Material selection will affect the weight, thickness and the friction against the bearings. Thickness can be calculated according to the below formula; (v = shear force)

$$\tau_{max} = 1.5 \frac{V}{A} \quad (4.3)$$

By calculating the maximum shear stress (τ_{\max}), minimum thickness of the blade can be decided. Note that it is important to remember the distribution of force on the interceptor blade is not linear, but polynomial. Refer to Figure 4.1.

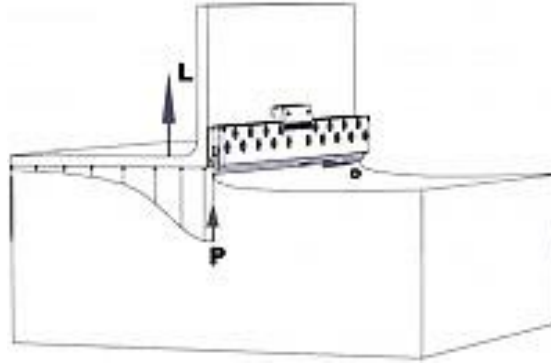

Figure 4.1 Pressure distribution [16]

4.3 Case/Housing

A housing to be designed to contain and protect the selected interceptor blade, appropriate bearings, required fastening elements and allows the actuator to work properly. Important items to consider during the design progress are as follows;

- Rigidity
- Ease of assembly
- Sufficient shear and tensile stress values for bolts or other fasteners
- Secure and long-lasting fastening
- Water-tightness towards inside of the vessel
- Working conditions to be considered as immersed in sea water or exposed to sea water splash
- Having no sharp corners exposed
- No obstacles to block the actuating movement
- Protection against corrosion and fouling
- Low bearing friction coefficient with the selected blade material

4.4 Reference Design

Sample vessel with below specifications was considered for the reference design [13] in this study:

- $L= 10.5$ m
- $B= 3.3$ m
- $\Delta= 4500$ kg
- $v= 45$ knots
- 2x385 hp Sterndrive Bravo II engines

Allowed space for the interceptor is given in Figure 4.2 (considering 50 mm margins from both sides of the vessel)

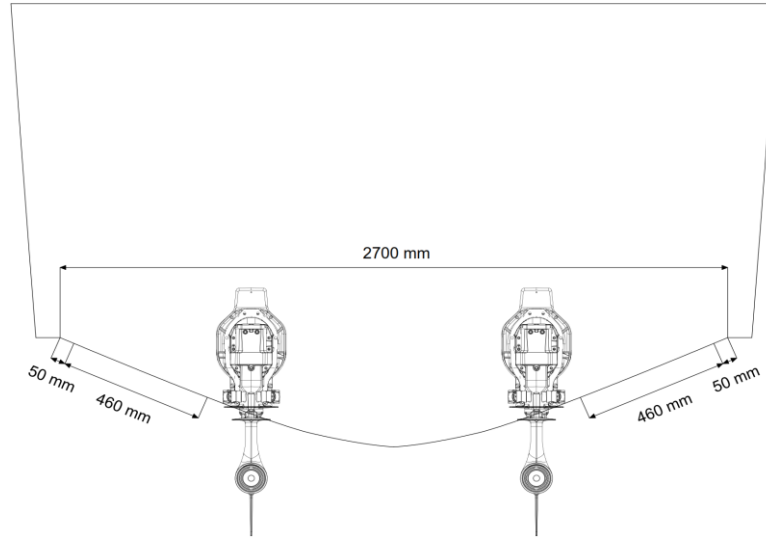

Figure 4.2 Sample vessel [13]

Interceptor blade's exposed area has dimensions of 450x50mm, using the maximum length available and the minimum extension length which provides the required lift force. Blade material is carbon fiber due to its high stiffness, lightness and low friction coefficient. The casing itself and the fastening components (except rubber gaskets) are AISI316. Bearing material is Aluminum Bronze (SS 5716-15) which is resilient against sea water and has a low friction coefficient. Actuator has a protection code of IP69K which is more than enough in such working conditions.

Reference design drawing is given in Figure 4.3.

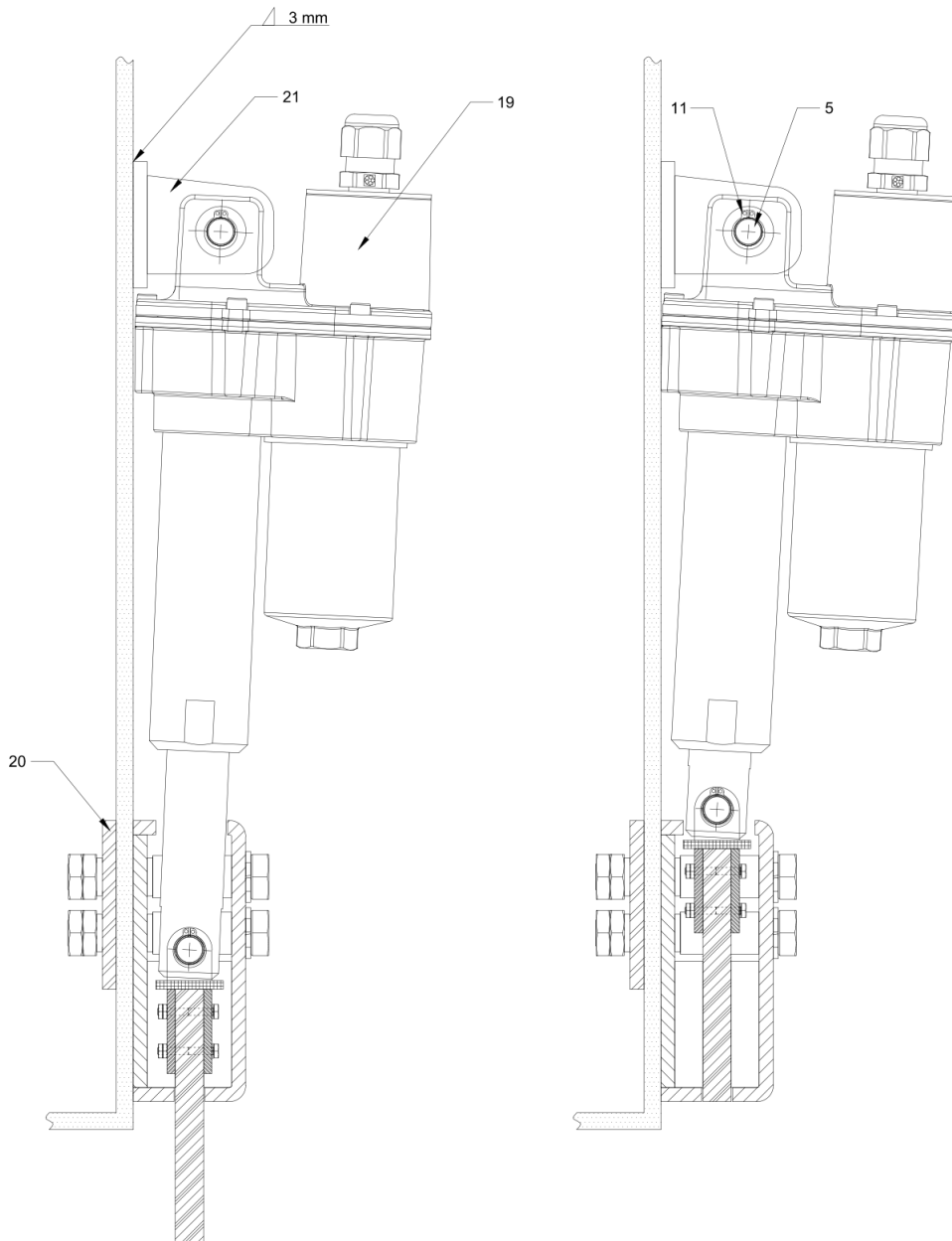

Figure 4.3 Actuator assembly [13]

5. Control Systems

Automatic control or operation of a process can be defined by the term automation [17]. First automated control system, as seen in Figure 5.1, was installed on Watts' steam engine in 1775, a flyball governor was connected to the shaft and by the rotational speed flyballs move up or down thus decreasing or increasing the inlet volume of steam supply valve to adjust shaft speed to a certain level. [18]

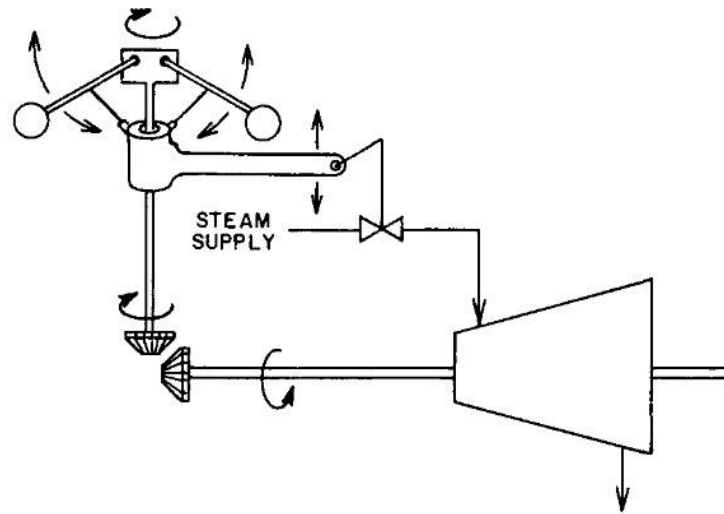

Figure 5.1 The first automated control system [18]

5.1 History of Control Systems

The development of machinery started with the more efficient factories due to the use of steam engines and water wheels in the 18th century England, which is the beginning of the modern manufacturing. Then in the early 1900s, accuracy of components such as bolts and nuts were increased by starting to produce them separately in identical batches instead of producing them individually according to a particular product. In 1909, Henry Ford's idea of production lines which breaks up the production process in sequences was a challenge.

Theoretical practices to control a process system using feedback were started in 1920s, the development of automatic steering for ships and aircrafts was a particular aim in these studies. Control systems were applied to military tasks (such as gun control or radar tracking) during the Second World War (1940s). In the mid-1900s, feedback amplifiers and tool positioning by numerical control was studied, thus developing open-loop control systems. Control systems were improved and developed to be used in wider application areas and to be cheap with the invention of the transistor (1948) and the inventions of microprocessors and computers (1970s). [17]

5.2 Open and Closed Loop Control Systems

There are two types of control systems; open-loop and closed-loop systems. In open-loop systems, the system output does not affect the input by any kind of feedback to adjust the desired output. When the loop is closed by a feedback signal, it is a closed-loop control system, this feedback signal is then used to adjust the inputs in order to acquire the optimum results with the desired/required outputs. [17]

Samples of open-loop (Figure 5.2) and closed-loop (Figure 5.3) control systems can be seen below.

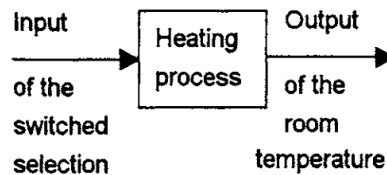

Figure 5.2 Open-loop system [17]

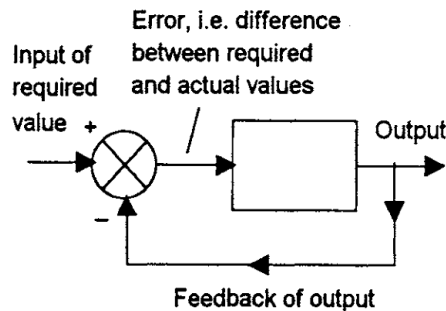

Figure 5.3 Closed-loop system [17]

Elements of a simple closed-loop can be sorted as follows;

- **Comparison Element:**
This element calculates an error value from the required value of the controlled variable and the achieved value provided from the feedback signal.
- **Control Element:**
Control element determines whether to increase or decrease the value of the input according to the calculated error value. Basically determines the course of action according to the error.
- **Correction Element:**
Correction Element is the actuating component which produces the change designated by the control element, e.g. an actuator, a motor or an air condition unit.
- **Process:**
Process is the system containing the variable that is being controlled. E.g. driven length of an actuator, rpm of a motor or temperature inside a vessel.
- **Measurement Element:**
Measurement element is the measurement signal from the controlled variable in the process.

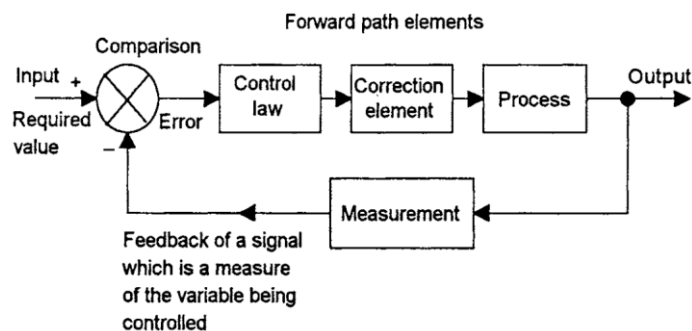

Figure 5.4 Closed loop elements [17]

In Figure 5.4 the upper row which includes the comparison element, the control element, the correction element and the process is the forward path, and the bottom row which includes the measurement element is the feedback path. [17]

5.3 Digital and Analog I/O

Basically there are two types of signals for both inputs and outputs, digital and analog. Digital signals are either 1 or 0 (e.g. depending on the input/output type; 5V or 0V, HIGH or LOW) not anything between. Analog signal can be any value in between these values for example, 2.3V or 4.56V etc.

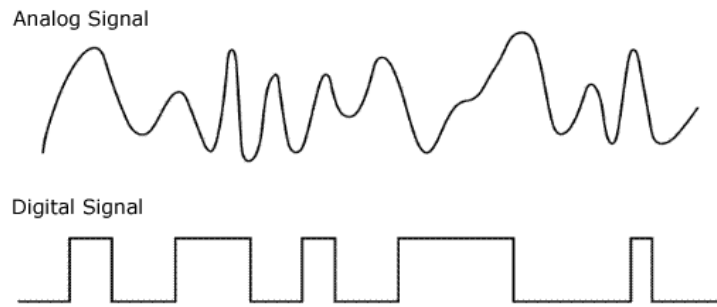

Figure 5.5 Analog and digital signals from different sources [19]

5.4 PWM (Pulse Width Modulation)

To mimic an analog output which drives the actuator to 30 mm for example, instead of initial point 0 mm and the utmost point of 50 mm (which is also the stroke length) digital output signal is not sufficient since it is only HIGH or LOW, 1 or 0, 5V or 0V. First option to drive the actuator to 30 mm length is to adjust the voltage as 3 volts, but with 3V the actuator will not have the sufficient torque to actuate the designated load at the designated speed. To drive the actuator on 30 mm length without the torque loss one should create an analog output but with the maximum power, the best option is PWM (Pulse Width Modulation). PWM signals can be simply explained as follows; during constant periods, “on” signal is given for a time (which is referred as the pulse width), and then “off” signal until next period. Duty cycle is proportional with pulse width which can be formulated as below. [20]

$$Duty\ Cycle = \frac{pulse\ on\ time}{pulse\ period} \times 100\% \quad (4.1)$$

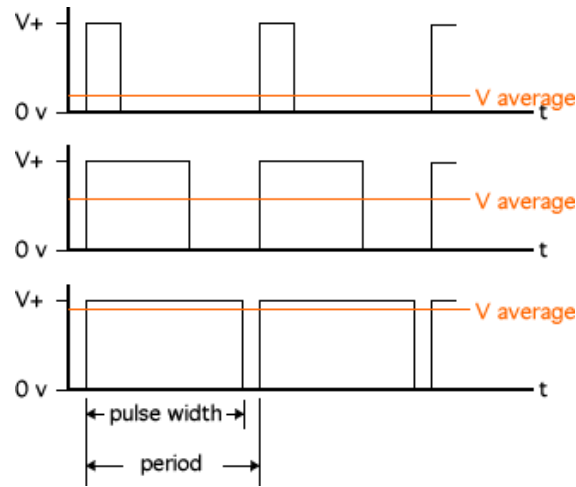

Figure 5.6 PWM [21]

5.5 PID

Desired output values can be adjusted by several methods in closed-loop systems. PID is the majority of the control types in the industrial applications. PID stands for Proportional, Integral and Derivative. Proportional path multiplies the error by a constant (K_p) while the integral path multiplies the error with a constant (K_i) then integrates it and the derivative path multiplies the error with a constant (K_d) then differentiates it.

These paths can be used alone as; P, I or D. Or used as PI, PD or PID according to the required output. In Figure 5.7 P, I and D control modes' treatment to the input signals can be observed.

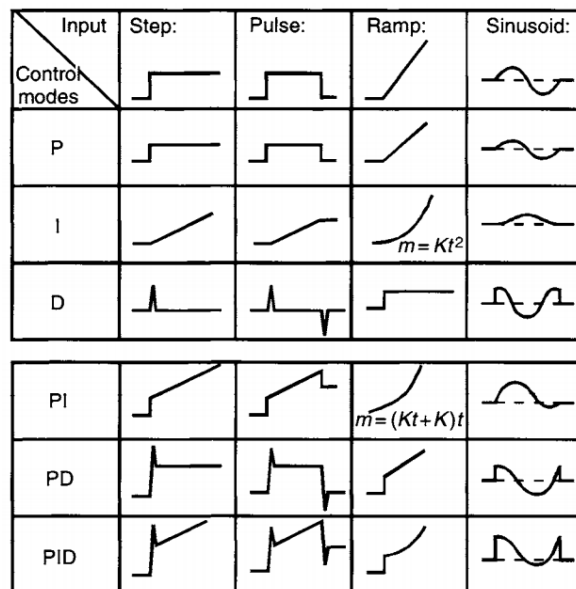

Figure 5.7 PID control modes [22]

5.6 Actuator Control

As the chosen actuator for the reference design, Thomson Max Jac actuator has available input voltages of either 12V or 24V. In this case 12V version is chosen, and e.g. for 50 mm stroke length, if desired actuated length is 25 mm then PWM signal should have 50% duty cycle, which will have a 6V average.

6. Marine Systems Control

Control systems can be used for many automation requirements/demands, such as;

- To give the autopilot a heading direction:
While rudder position and steering gear will be controlled according to compass measurements, external disturbances or changes in the conditions for example; wind/wave conditions, ship draught and water depth may interrupt this progress.
- To maintain cooling water temperature of a diesel engine:
Coolant flow will be controlled with flow control valves according to the readings from the thermocouple at diesel engine cooling water outlet. Meanwhile engine load variations and sea water temperature variations may disturb this process.
- To maintain diesel generator engine speed and electrical frequency:
Fuel pump/governor will be used to control engine fuel flow according to the measurements from the tachometer, while the electric load and ambient conditions may vary thus causing external disturbances. [23]

Above examples can be varied furthermore, since marine crafts have many equipment and systems.

7. Interceptor Control

By having required components and sufficient programming knowledge, one can prepare an interceptor control project.

Components can be exemplified as below;

- Pair of Interceptors
- Pair of Actuators
- DC Power Source
- Microprocessor
- DC Motor Driver
- GPS
- Accelerometer
- Gyroscope

In this case; interceptors are custom-engineered, actuators are supplied from a manufacturer, vessel's generated power can be used as the power source, an arduino or two can be used as microprocessor (or Raspberry Pi, PIC devices or a PLC device such as Siemens S7-1200),

motor driver chipset or motor driver shield and three sensors (GPS, accelerometer and gyroscope) either combined or separate.

To eliminate the “white noise” from the sensors, a filtering should be used during programming; complementary filter, Mahony filter or Kalman filter can be used. Then these three sensors can provide useful outputs such as; speed, acceleration, trim angle, roll or heel angle. With mentioned data one can design and program an interceptor control system, furthermore, can optimize it according to the boat characteristics for better results.

Furthermore, the system can be optimized with PID. Actuator position feedback is required for exact positioning of the interceptor.

8. Conclusion

In conclusion, mechanical design and automatic control of an interceptor system can be done according to aforementioned details. Important topics such as the interceptor blade area calculation, or the ease of manufacturing, assembly and maintenance should be considered during the design stage. For the control stage, even though there are many ways to create the control system, motor controller system is one of the simplest ways. Further works may include stabilizing vessel’s roll movements according to the readings from gyroscope, optimizing interceptor stroke according to the trim angle or the vessel’s speed or even a complete stabilizing system.

References

- [1] Molland, Anthony F. The Maritime Engineering Reference Book. s.l. : Elsevier, 2008.
- [2] Potgieter, Kobus. Articles. KND. [Online] October 7, 2006. [Cited: March 19, 2016.] <http://www.navaldesign.co.za/articles.html>.
- [3] Faltinsen, Odd M. Hydrodynamics of High-Speed Marine Vehicles. Cambridge : Cambridge University Press, 2005.
- [4] Volvo Penta. Powertrim Assistant. Volvo Penta. [Online] 2015. [Cited: March 20, 2016.] http://www.volvopenta.com/volvopenta/na/en-us/marine_leisure_engines/accessories/Trimsystems2/Pages/PTA.aspx.
- [5] Emery, Charles E. Apparatus for regulating the rolling and pitching of vessels. 471,212 United States of America, 1892.
- [6] Noll, Henry John. Adjustable fin for vessels. 767,827 United States of America, 1904.
- [7] Anderson, Emil S. Extension attachment for boats. 2,576,744 United States of America, 1947.
- [8] Herz, Johannes. Boat having pivotable underwater hydrofoils. 2,713,317 Germany, 1955.
- [9] Bennett, Charles H. Trim attachment for power boats. 3,062,167 United States of America, 1962.

- [10] Jacobs, Joseph H. and Jacobs, Marcellus L. Adjustable planing-floats for power boats. 2,985,130 United States of America, 1961.
- [11] Olofsson, Bo. Arrangement for dynamic control of running trim and list of a boat . 6,006,689 United States of America, 1999.
- [12] Bennett Trim Tabs. Why do I need Trim Tabs? Bennett Trim Tabs. [Online] [Cited: March 24, 2016.] <http://www.bennetttrimtabs.com/tech-help/why-do-i-need-trim-tabs/>.
- [13] Tunçer, Ataol. Trim Tab Design for the High Speed Craft. Istanbul : Istanbul Technical University, 2015.
- [14] Maritime Dynamics. Naiad Dynamics. Interceptors/Trim Tabs/Force Producers for Ship Motion Control. [Online] [Cited: March 27, 2016.] <http://naiaddynamics.com/interceptor.pdf>.
- [15] Zipwake. Zipwake. [Online] [Cited: March 27, 2016.] <http://www.zipwake.com/assets/images/Compare%20info.png>.
- [16] Humphree. Humphree. How it Works. [Online] [Cited: March 28, 2016.] <http://www.humphree.com/learn-more/how-it-works/>.
- [17] Bolton, William. Control Systems. Oxford : Newnes Elsevier, 2002.
- [18] Lipták, Béla G. Instrument Engineers' Handbook, Third Edition: Process Control. s.l. : CRC Press, 1995.
- [19] King, Paul. Is the human brain analog or digital? Quora. [Online] December 07, 2014. [Cited: April 06, 2016.] <https://www.quora.com/Is-the-human-brain-analog-or-digital>.
- [20] Toulson, Rob and Wilmshurst, Tim. Fast and Effective Embedded System Design Applying the ARM mbed. Oxford : Elsevier (Newnes), 2012.
- [21] Dedeoglu, Kemal. Pulse Width Modulation - Darbe Genişlik Modülasyonu. Güç Elektroniği. [Online] 2014. [Cited: April 06, 2016.] <http://powerelectronicsdesign.blogspot.com.tr/2014/04/pulse-width-modulation-darbe-genislik.html>.
- [22] Altmann, Wolfgang. Practical Process Control for Engineers and Technicians. Oxford : Elsevier (Newnes), 2005.
- [23] Roskilly, Tony and Mikalsen, Rikard. Marine Systems Identification, Modeling and Control. s.l. : Elsevier (Butterworth-Heinemann), 2015.