

Fuzzy and Neuro-Fuzzy Forecasting Approaches to Whiplash Effect in Supply Chains

Tedarik Zincirlerinde Kırbaç Etkisine Bulanık Ve Sinirsel-Bulanık Yaklaşımlar

Hakan TOZAN¹, Özalp VAYVAY²

Turkish Naval Academy Dept. of Industrial Engineering, Istanbul, Turkey¹

Marmara University Dept. of Industrial Engineering, Istanbul, Turkey²

htozan@dho.edu.tr, ovayvay@eng.marmara.edu.tr

Abstract

The whiplash or bullwhip effect bullwhip is simply the variability of the demand information between stages of the supply chain and the increase of this variability as the information moves upstream through the chain. The selection of the appropriate forecasting model that best fits the demand pattern is not an easy decision but is among the corner stones of smoothing this undesirable variability. This paper analyze the effects of fuzzy linear regression, fuzzy time series and neuro-fuzzy forecasting models on supply chain performance quantifying the demand variability through the stages in a simple supply chain Matlab simulation.

Özetçe

Kırbaç etkisi basit olarak, tedarik zinciri safhaları arasında talep bilgisindeki değişkenlik ve zincirde bilgi üst seviyelere ilerledikçe bu değişkenlikteki artıştır. Talep yapısına en uygun tahmin yönteminin seçimi kolay olmayan bir karar olmasına rağmen, bu istenmeyen değişkenliğin yumuşatılmasında önemli yapı taşlarından bir tanesidir. Bu çalışma, bulanık lineer regresyon, bulanık zaman serileri ve sinirsel-bulanık tahmin modellerinin tedarik zinciri performansı üzerindeki etkilerini Matlab tabanlı sade bir tedarik zinciri benzetimi yardımı ile talep değişkenliğini sayısallaştırarak analiz etmektedir.

Keywords: Supply chain, Whiplash Effect, Forecasting, Fuzzy regression, Fuzzy time series, Neuro-fuzzy, ANFIS, Exponential Smoothing.

Anahtar Kelimeler: Tedarik zinciri, Kırbaç etkisi, Tahminleme, Bulanık regresyon, Bulanık zaman serileri, Sinirsel-Bulanık, ANFIS, Üssel Düzeltme.

1. Introduction

In today's competitive business environment the competition power of companies and even countries (in public or military applications) in the international business area are mainly based on customer relations; understanding the needs of customer and ability of immediate response to those needs. These activities include many sophisticated related functions either directly or indirectly based on the customer demand or more specifically, what customer wants; such as a new product development, production, marketing, distribution, finance, management and ect. These complex structures with all related functions have to be managed perfectly pointing us to well-known terms supply chain (Sc) and Sc management (ScM). Sc models are dynamic systems including many sophisticated activities such as constant on time information, scheduling, production, distribution, services and decision making processes which are all required for satisfying the customer demand. A simple definition for these complex systems can be express as "the network of organizations that are involved, through upstream and downstream linkages, in the different process and activities that produce value in the form of products and services in the hand of ultimate customer" [1]. Although the information flow in Sc systems consists of cumulative data about costs parameters, production activities, inventory systems and levels, logistic activities and many other related processes; bethinking of the definition exposes that the performance of a successful Sc system concerns mostly with accurate and appropriate demand information as this vital data influences all decision making processes of Sc [2].

A well-known phenomenon of Sc systems is the variability of the demand information between the stages of the supply chain (i.e. the whiplash or bullwhip effect (WE).) This variability increases as the demand data moves upstream from the customer to the other stages of the SC system engendering undesirable excess inventory levels, defective labor force, cost increases, overload errors in production activities and etc. Just like many other Sc related research topics, WE also have a long research history. From 1952 till 2008 many studies have been done about WE. However, very few

of them interested in fuzzy system approaches to WE. The first academic research on WE grounds on Forrester [3, 4]. In his pioneer empirical work, using a simple four echelon supply chain simulation (retailer, wholesaler, distributor and factory) he discovered the existence of the ‘demand amplification’ which later denominated by P&G as WE. He argued about the possible causes and suggested some ideas to control the WE. He emphasized on the decision making process in each phase of SC and betrayed that this process could be the main reason the demand amplification through the chain from the retailer to the factory level [2]. He also denoted that, time lags for clerical work, purchasing and transportation, lead times and specific factory capability could be other likely reasons of WE. Like Forrester, Sterman [5, 6] also focused on the existence and causes of WE. He used an experimental Sc simulation that simulate the beer distribution in a simple Sc consists of four echelons; retailer, wholesaler, distributor, factory which is then became a well-known Sc simulation model; "Beer Distribution Game", widely used for teaching the behavior, concept and structure of Sc. The model was so simple but despite to its simplicity, it successfully showed the impact of the decision process in echelon on the demand variability. Main objective is to govern each echelon achieving the desired inventory and pipeline levels minimizing the total cost including inventory and shortage costs. Fig.1 illustrates the general system structure of a beer game [7].

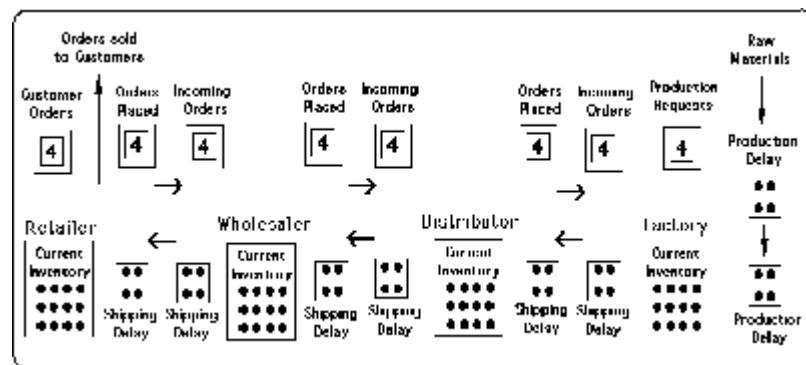

Figure 1. The System Structure of Beer Game.

Sterman apprised that inaccurate judgments made by the participants and the adoption of these judgments to the Sc system are the main reason of this phenomenon. Larsen *et al.* [8]; using a Sterman based beer game model, showed that the structure of a production-distribution chain produce broad variety of dynamic behaviors. In the study different types of behaviors are summarized with Lypunov exponents. There were two important assumptions in the model; i) the parameters of the decision rule is constant, (i.e, remain the same through the entire solution), ii) decisions in each stage constituted under the information available in each stage. Larsen *et al.* after showing the effect of inventory control policies on dynamics and costs concluded that "a sophisticated management information system" and reducing time lags are important keys for reduction in demand amplification and costs. Also they claimed that "interlocking" common parameters in ordering policies might cause high cost and intricacy dynamics. Lee *et al.* [9, 10, 11, 12] declared causes of WE as: price fluctuations, rationing game, order batching, lead times and demand forecast updating. Baganha *et al.* [13], Graves [14], Drezner *et.al* [15], Chen *et al.*[16] and Li *et al.* [17] also studied WE from the perspective of information sharing and demand forecasting / updating. Based on the idea of treating systems (including ordering activities) as a filter from control theory, Dejonckheere *et al.* [18, 19, 20], Disney *et al.* [21, 22, 23, 24] and Geary *et al.* [25] used control theory approach to investigate this phenomenon and obtained remarkable results for WE reduction.

An important managerial object to cope with WE is appropriate demand prediction. But through system uncertainties, variable and deficient demand information, determining the proper forecasting model for the system snarl [2]. Although not much attention is paid on their usage in Sc systems; when sample data that will used for prediction is relatively few and the analyzed system is raging under uncertainties similar to chaotic nature of Sc, the fuzzy forecasting models such as fuzzy time series (FT) [26, 27, 28, 29, 30, 31], fuzzy linear regression (FL) [32, 33, 34] and neuro-fuzzy (NF) forecasting models [35, 36, 37,] performed successfully. This paper focuses on the effects of selected fuzzy and neuro-fuzzy forecasting models on demand variability in Sc systems quantifying WE using proposed near beer

game multi echelon Sc Matlab simulation extended with cost, time, different demand patterns and fuzzy parameters.

The following sections of the paper are organized as follow. In section 2, FT, FR, FGG and NF forecasting models are introduced. In section 3, BWE is quantified in terms of demand variances. In section 4, the Sc simulation model is introduced. Finally in sections 5 and 6 the effects of selected forecasting models on demand variability is examined and findings and conclusions are presented.

2. Fuzzy and Neuro-Fuzzy Forecasting Models

2.1 FR Forecasting Model

Linear regression; which shows the relation between response or dependent variable y and independent or explanatory variable x , can be formulate considering the relation of y to x as a linear function of parameters with $Y = f(x) = \theta X$ where θ is the vector of coefficients and X is the matrix of independent variable [38]. The application of linear regression model is suitable for the systems in which the data sets observed are distributed according to a statistical model (i.e. unobserved error term is mutually independent and identically distributed). But generally, fitting the demand pattern of a real Sc to a specific statistical distribution is not possible. The FR model introduced by Tanaka *et al.* [32, 33] in which “deviations reflect the vagueness of the system structure expressed by the fuzzy parameters of the regression model” (i.e. possibilistic) is suitable for the declared demand patterns and basically can be formulate as:

$$\bar{Y} = (c_0, s_0) + (c_1, s_1)x_1 + (c_2, s_2)x_2 + \dots + (c_n, s_n)x_n \quad (1)$$

where c_k is the central value and s_k is the spread value, of the k th fuzzy coefficient; $\bar{A}_k = (c_k, s_k)$, usually presented as a triangular fuzzy number (TFN). And this representation is fact that relaxes the crisp linear regression

model. The degree of belonging of observations y_i to \bar{Y}_i ; that characterized by h as :

$$\mu_{Y_i}(y_i) \geq h, \quad i = 1, 2, 3, \dots, m \quad (2)$$

As s_k shows the fuzziness of A_k , to get minimum fuzziness in FR, the total spread of the fuzzy output parameter \bar{Y}_k must be minimized. Usage of fuzzy triangular membership function for the coefficients in the model enables the usage of linear programming (LP) for solutions. So, the minimum fuzziness for \bar{Y}_k can be maintained with a LP model as follow [2, 33, 38, 39];

$$Z = \text{Min} \left\{ ms_0 - (1-h) \sum_{i=1}^m \sum_{k=0}^n s_k x_{ik} \right\}$$

St

$$\sum_{k=1}^n c_k x_{ki} - (1-h) \sum_{k=1}^n s_k x_{ki} \leq y_i$$

$$\sum_{k=1}^n c_k x_{ki} - (1-h) \sum_{k=1}^n s_k x_{ki} \geq y_i$$

where $x_{0i} = 1, 0 \leq h \leq 1; \quad \forall_k = 1, 2, 3, \dots, n \quad \forall_i = 1, 2, 3, \dots, n.$

2.2 FT Forecasting Model

For systems in which the historical demand data that will use to calculate the desirable forecast value are linguistic values and (or) are in small amounts (just like the situation in many Sc) FT model best fit the aspect [29, 30, 31]. Song *et al.* [26, 27, 28]; fuzzifying the enrollments of the University of Alabama, used fuzzy time series in forecasting problems and proposed a first-order time-variant fuzzy time series with first-order time-invariant fuzzy time series for the solution of the forecasting problems. Later Song *et al.* [28] introduced a new FT model and betrayed that best results are held by applying neural network for defuzzifying data. Wang

[29], Li *et al.*[30] and Hwang *et al.* [40] also successfully used FT forecasting model. Hwang's FT models simply can be summarized as follow:

- I. First, the variation between two continuous historical data is to be calculated and minimum / maximum increases (i.e. D_{\min} / D_{\max}) are to be determined,
- II. Next step is to define the universe discourse; U_d , with following equation using D_{\min} and D_{\max} ,

$$U_d = [D_{\min} - D_1, D_{\max} + D_2] \quad (3)$$

where D_1 and D_2 are positive values that fits for separating U_d into equal lengths. Then fuzzy sets on U_d are to be defined (i.e. defining fuzzy time series ($F(t)$) and variation data is to be fuzzified. Defining $F(t)$ as:

$$F(t) = p_{z1}/u_1 + p_{z2}/u_2 + \dots + p_{zm}/u_m \quad (4)$$

where the memberships p_{zi} are $0 \leq p_{zi} \leq 1$. The fuzzy sets A of U then can be represented as;

$$A = \left\{ p_{z1}/u_1 + p_{z2}/u_2 + \dots + p_{zm}/u_m \right\} \quad (5)$$

Fuzzifications of variations are determined according to u_i that they fit.

- III. And the final step includes composing the relation matrix; $R(t)$, which is governed by operation and criterion matrixes (i.e. $O^w(t), Z(t)$) and defuzzifying the calculated variation [28, 31] which will be used for estimating the forthcoming value using the relation of the chance value gathered from relation matrix. In this step the windows basis; w , have to be determined which shows the number of periods of variations that will be used for forecasting. For period t , $O^w(t), Z(t)$ and $R(t)$ is defined as follow [40]:

$$Z(t) = F(t-1) = [Z_1, Z_2, Z_3, \dots, Z_n] \quad (6)$$

$$O^w(t) = \begin{bmatrix} F(t-2) \\ F(t-3) \\ \cdot \\ \cdot \\ F(t-w-1) \end{bmatrix} = \begin{bmatrix} O_{11} & O_{12} & \dots & O_{1m} \\ O_{21} & O_{22} & \dots & O_{2m} \\ \cdot & \cdot & \cdot & \cdot \\ \cdot & \cdot & \cdot & \cdot \\ O_{w1} & O_{w2} & \dots & O_{wm} \end{bmatrix} \quad (7)$$

$$R(t) = \begin{bmatrix} O_{11} \times Z_1 & O_{12} \times Z_{11} & \dots & O_{1m} \times Z_m \\ O_{11} \times Z_1 & O_{12} \times Z_{11} & \dots & O_{1m} \times Z_m \\ \cdot & \cdot & \cdot & \cdot \\ \cdot & \cdot & \cdot & \cdot \\ O_{11} \times Z_1 & O_{12} \times Z_{11} & \dots & O_{1m} \times Z_m \end{bmatrix} \quad (8)$$

where $1 \leq j \leq m$ and $R_{ij} = O_{ij} \times Z_j$, $1 \leq i \leq w$. Then the estimated variation will be determined with the following equality;

$$F(t) = [r_1, r_2, \dots, r_m] \quad (9)$$

where $r_j = \text{Max}(R_{ij})$; $i = 1, 2, \dots, w$ and $j = 1, 2, \dots, m$. The forecast value for the period t is calculated by defuzzification of $F(t)$ and adding this value to the actual data of the period $t-1$ and this operation concludes the FT forecasting method.

2.3 NF Forecasting Model

Because of artificial neural networks ability of learning and easily identifying patterns and fuzzy inference systems' (FIS) ability of incorporating human knowledge and performing inference, the combination

of these two systems; i.e. NF; became one of the most popular soft computing forecasting approaches. An artificial neural network (ANN) can simply be defined as “a parallel, distributed information processing structure consisting of processing elements (-which can possess a local memory and can carry out localized information processing operations) interconnected via unidirectional signal channels called connections.”[41]. The name is given to this mathematical information processing system because of its similar functioning structure to biological neural system in brain. Basically neurons in biological neural systems correspond to nodes and synapses correspond to weighted links in ANN. [42]. Researches on ANN can be based on the study of McCulloch and Pitts [43] about computation of arithmetic or logical function with networks of artificial neurons and configuration of any arbitrary logical function by a neural network of interconnected digital. Another milestone study for ANN is introduced by Rosenblatt [44] in which, a learning algorithm and pattern recognition in a perceptron network is demonstrated. With the pioneer works of Parker [45], and Rumelhart *et al.*[46] about backpropagation (i.e., a method of training a multilayer neural network), usage of ANN became prevalent nearly every field of science including forecasting. As FIS (which base on the fuzzy sets, fuzzy if-then rules and fuzzy reasoning) infer information from defined rules, the combination of ANN and fuzzy logic (i.e., NF) became a powerful and extremely successful methodology together with adaptive network based fuzzy inference system (ANFIS, see [47]) in many fields of science including decision making, control theory, system engineering, operations research, forecasting and etc. Past studies showed that NF and adaptive network based fuzzy inference system (ANFIS) forecasting models perform successfully in dynamic systems with highly uncertainties in and uncontrollable parameters (i.e., human behavior) like Sc. Fig.2 illustrates a general five layer neuro-fuzzy architecture [42].

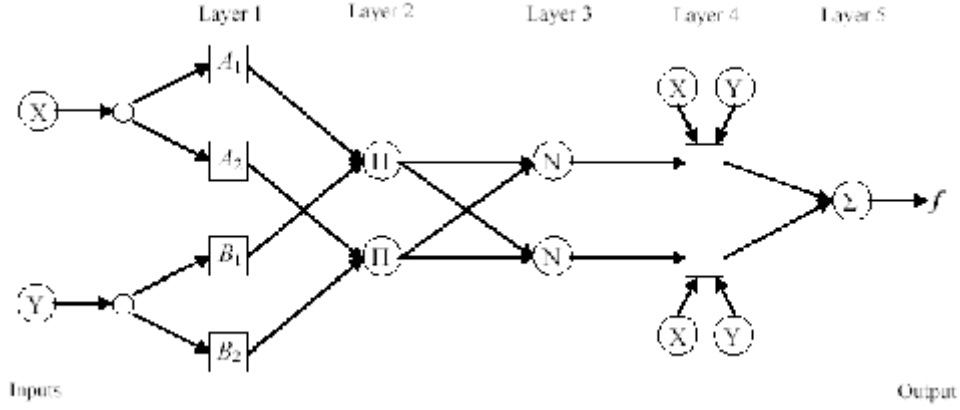

Figure 2. A Neuro-Fuzzy Architecture.

3. Quantification of WE

This study quantifies the demand variability (i.e. WE) in various stages of the proposed Sc simulation defining WE as the ratio of demand variances of two consequent stages with Chen *et al.*'s model [38]. The performance will be measured via WE as the smaller the WE the better the Sc performance will be. Chen *et al.*; assuming the customer demand in period t to the retailer (D_t) as random variables; defined D_t with the following equation.

$$D_t = \mu + D_{t-1}\rho + \varepsilon_t' \quad (10)$$

where μ and ρ denotes a non negativity constant and correlation parameters ($|p| < 1$) respectively (as ρ indicates the relationship between demands $\rho = 0$ betrays the independent identically distributed (i.d.d.) demand). The variance of D_t is emerged as

$$Var(D_t) = \frac{\delta^2}{1 - \rho^2} \quad (11)$$

and assuming the inventory system in the retailer is order-up-to policy with fixed lead time WE is quantified as $Var(q)$ relative to $Var(D)$ (see [2, 38]).

4. The Simulation Model

In this study a near beer distribution game model is used; which is extended from the Paik's [48] model with predetermined cost items (holding, setup / production), inventory restrictions, production restrictions and delay functions. The beer game model; which is an effective tool for investigating the behaviors and factors effecting Sc performance as it successfully can reflect the attitude of the real life models, was introduced by Sterman [6]. The model proposed here, is simply a two staged Sc system consists of a retailer and a factory. Due to its common use and successful primed fuzzy functions; MatLab is the adjudicated simulation tool. Demand information in each period can be either crisp or fuzzy depending on the forecasting model that will be analyzed; similar to our previous model [2]. The model evaluates the Sc performance by computing the ratio of demand variances of consequent stages; i.e. $VarD_{S_i} / VarD_{S_{i+1}}$ where D_{S_i} denotes the demand from stage S to upstream stage S_{i+1} and (i.e., $i = c, r, f$ where c, r, f represent customer, retailer, factory respectively). The cost, delay and factory production capacity parameters are variable and their values depend on the analyzer. The generic decision rule in each time period t can be summarized with the following equation [2, 6].

$$\text{Upstream Order Quantity} = [\text{Forecast Value} + \text{Correction of Inventory} + \text{Correction for Supply Line}] \quad (12)$$

Simple exponential smoothing (EXS) model is used as a crisp forecasting technique for comparison. The customer order received from retailer in period t is taken as a base for forecasting the forthcoming demand, and each time the order received, forecasting function update its structure according to the new demand information. After estimating the forthcoming demand; simulation model, using the decision rule in (12) and other parameters (i.e. cost, lead time, availability, demand pattern etc.), makes an

ordering decision to upper echelon of Sc. And the ratio of variability between the customer orders, retailer orders and manufacturing decision of factory shows the performance of Sc system based on the selected forecasting model.

5. The Experiment

The following figures in the next page illustrate randomly generated D_c (the same for all simulation runs), and calculated D_r and D_f values derived from the simulations using selected forecasting methods for a time horizon of 30 periods. And to reflect the response of Sc performance to the selected forecasting model, the calculated standard deviation values are given Table-1 (variance values can also obtain using Table-1). In the simulations, the production capacity of factory is taken as 100 units per period and on hand inventory in each echelon at time zero is set to again 80 units. Smoothing constant for crisp model is taken as 0.9, adjustment parameters α and β are both 0.5 and safety stock rate is two periods, total delay for each echelon is 4 periods [see 5, 6 and 48]. For NF forecasting the values, parameters and optimization method for training for ANFIS are: the error tolerance is zero, the number of epoch is 50, and training FIS optimization method is hybrid and the membership functions for FIS are triangular. The set of D_c values for 30 periods; D_{set} , are given below.

$D_{set} = \{66 \ 62 \ 76 \ 56 \ 36 \ 47 \ 50 \ 59 \ 52 \ 38 \ 36 \ 28 \ 49 \ 57 \ 43 \ 40$
 $49 \ 46 \ 30 \ 75 \ 58 \ 75 \ 40 \ 27 \ 66 \ 50 \ 34 \ 48 \ 60 \ 71\}.$

6. Research Findings and Conclusion

In this study the effects of selected fuzzy forecasting models; FR, FT and NF, on Sc performance are analyzed using computed demand variability as a ratio of variances of consequent stages (i.e.WE). For comparing the obtained results of the simulation using fuzzy forecasting, EXS forecasting model is chosen as a base crisp forecasting model. A simple numerical example is made using random generated demand data. The results exposed

that the fuzzy forecasting models used in the study quickly captured the demand pattern and considerably increased the performance of proposed Sc system decreasing demand variability and through the chain. In our working paper a different FIS and NF model is adapted to a four echelon Sc simulation model and cost/inventory parameters also examined. But as the finding are beyond the scope of this paper, they are not mentioned here. Further researches can be made using fuzzy costs, fuzzy inventory systems and fuzzy lead times as to more adapt the model to complex real-world Sc systems.

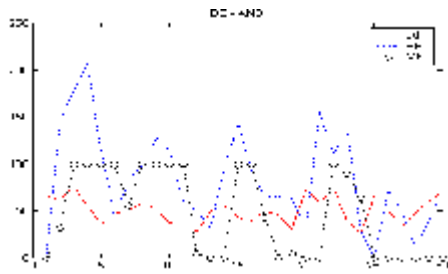

Figure3. Demand response to EXS forecasting model

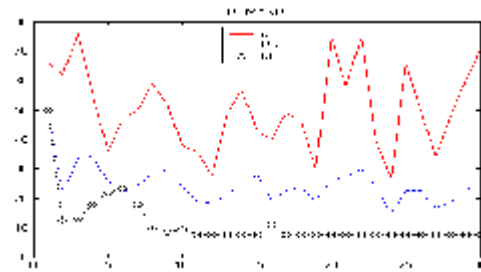

Figure 4. Demand response to NF forecasting model

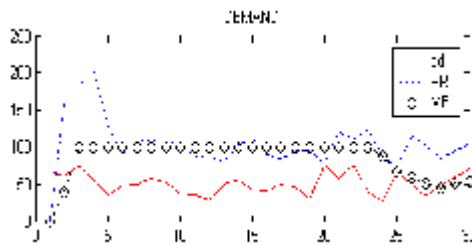

Figure4. Demand response to FR forecasting model

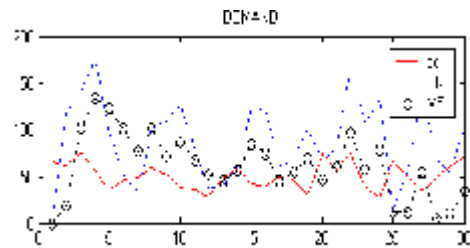

Figure 4. Demand response to FT forecasting model

Fuzzy and Neuro-Fuzzy Forecasting Approaches to Whiplash Effect in Supply Chains

Forecasting Model				
S.Deviations	EXS	NF	FR	FT
Sd_c	14.17	14.17	14.17	14.17
Sd_r	52.46	6.36	35.22	43.38
Sd_f	46.74	8.589	26.34	34.74

References

- [1] Christopher M., Logistic and Supply Chain Management, *Pitman Publishing, London, UK*, 1994, pp.30.
- [2] Tozan H., Vayvay O., Analyzing Demand Variability Through SC Using Fuzzy Regression and Grey GM(1,1) Forecasting Models, *Information Sciences 2007, World Scientific*, 2007, pp. 1088--1094.
- [3] Forrester J., Industrial Dynamics: A major breakthrough for decision makers, *Harvard Business Review*, 36, 1958, pp. 37--66.
- [4] Forrester J., Industrial Dynamics, *MIT Press, Cambridge, MA*, 1961.
- [5] Sterman J.D., Modeling Managerial Behavior: Misperception of Feedback in a Dynamic Decision Making Experiment, *Management Science*, 35, 1989, pp.321-399.
- [6] Sterman J.D., Deterministic Chaos in an Experimental Economic System, *Journal of Economic Behavior and Organization*, 12, 1989, pp.1-28.
- [7] <http://beergame.uni-klu.ac.at/bg.htm>, 2008.
- [8] Larsen E.R., Morecroft J.D., Thomsen J.S., Complex Behavior in a Production-Distribution model, *European Journal of Operation Research*, 119, 1999, pp. 61-14.
- [9] Lee H. L., Padmanabhan V., Whang S., The Bullwhip Effect in Supply Chains, *MIT Sloan Management Rev.*, 38, 1997a, pp. 93-10 2.
- [10] Lee H. L., Padmanabhan V., Whang S., Information Distortion in a Supply Chain: The bullwhip effect, *Management Science*, 43, 1997b, pp. 546--558.
- [11] Lee H. L., Aligning Supply Chain Strategies with Product Uncertainties, *California Management Review*, 44, 2002, pp. 105-119.
- [12] Lee H. L., Padmanabhan V., Whang S., Information Distortion in a Supply Chain: The bullwhip effect, *Management Science*, 50, 2004, pp. 1875--1886.
- [13] Baganha M., Cohen M., The Stabilizing Effect of Inventory in Supply Chains, *Operations Research*, 46, 1998, pp.572-583.
- [14] Graves S. C., A Single Inventory Model foe a Nonstationary Demand Process, *Manufacturing &Service Operations Management*, 1, 1999, pp.50-61.
- [15] Drezner Z., Ryan J., Simchi-Levi D., Quantifying the Bullwhip Effect: The impact of forecasting, lead time and information, *Management Science*, 46 (3), 2000, pp.436-443.
- [16] Chen F., Drezner Z., Ryan J., Simchi-Levi D.,The Impact of Exponential Smoothing Forecasts on the Bullwhip Effect, *Naval Research Logistics*, 47, 2000, pp. 269-286.

- [17] Li G., Wang S., Yan H., Yu G., Information Transportation in Supply Chain, *Computers and Operation Research*, 32, 2005, pp. 707-725.
- [18] Dejonckheere J., Disney S.M., Lambrecht M., Towill D.R., Transfer function analysis of forecasting included bullwhip in supply chains, *Int.J. Production Economics*, 78, 2002, pp. 133-144.
- [19] Dejonckheere J., Disney S.M., Lambrecht M., Towill D.R., Measuring and avoiding the bullwhip effect: A control theoretic approach, *European Journal of Operational Research*, 147 2003, pp.567-590.
- [20] Dejonckheere J., Disney S.M., Lambrecht M., Towill D.R., The impact of information enrichment on the bullwhip effect in supply chains: A control engineering perspective, *European Journal of Operational Research*, 153, 2004, pp. 727-750.
- [21] Disney S.M., Towill D.R., On the bullwhip and inventory variance produced by an ordering policy, *International Journal of Management Science*, 31 2003a, pp. 157-167.
- [22] Disney S.M., Towill D.R., The effect of vendor managed inventory (VMI) Dynamics on the bullwhip effect in supply chains, *International Journal of Production Economics*, 85 (2003b) 199-215.
- [23] Disney S.M., Towill D.R., Velde W., Variance amplification and the golden ratio in production and inventory control, *International Journal of Production Economics*, 85, 2004, pp. 295-309
- [24] Disney S.M., Farasyn I., Lambrecht M., Towill D.R., Van de Velde W. Taming the bullwhip effect whilst watching customer service in a singular supply chain echelon, *European Journal of Operational Research*, 173, 2006, pp.151-172.
- [25] Gaery S., Disney S.M., Towill D.R., On bullwhip in supply chains-historical review, present practice and expected future impact, *International Journal of Production Economics*, 101, 2006, pp. 2-18.
- [26] Song Q., Chissom B. S., Forecasting Enrollments with Fuzzy Time Series, *Fuzzy Sets and Systems*, 54, 1993, pp. 1-9.
- [27] Song Q., Chissom B. S., Fuzzy Time Series and Its Models, *Fuzzy Sets and Systems*, 54, 1993, pp. 269-277.
- [28] Song Q., Chissom B. S., Forecasting Enrollments with Fuzzy Time Series Part II, *Fuzzy Sets and Systems*, 62, 1994, pp. 1-8.
- [29] Wang C.H., Predicting Tourism Demand Using Fuzzy Time Series and Hybrid Grey Theory, *Tourism Management*, 25, 2004, pp.367-374.
- [30] Li S., Cheng Y., A Hidden Markov Model-based Forecasting Model for Fuzzy Time Series, *WSEAS Transactions on System*, 5, 2006, pp. 1919-1925
- [31] Kahraman C., Fuzzy Applications in Industrial Engineering,, 1th edt., *Springer*, 2006, pp.40–55.
- [32] Tanaka H., Uejima S., Asai K., Fuzzy Linear Regression Model, *IEEE Trans. System, Man and Cybernet*, 12 , 1982, pp. 903-907.,
- [33] Tanaka H., Watada J., Possibilistic Linear Systems and Their Application to the Linear Regression Model, *Fuzzy Sets and Systems*, 27, 1988, pp.275–289.

Fuzzy and Neuro-Fuzzy Forecasting Approaches to Whiplash Effect in Supply Chains

- [34] Wang, H.F., Tsaur R.H., Insight of a Fuzzy Regression Model, *Fuzzy Sets and Systems*, 2000, 112, pp. 355-369.
- [35] Escoda I., Ortega A., Sanz A., Herms A., Demand Forecasting by Neuro-Fuzzy Techniques, *Proceedings of Sixth IEEE Int.Conf. on Fuzzy Systems*, 1982, pp. 1381-1386.
- [36] Kuo R.J., A Sales Forecasting System Based on Fuzzy Neural Network with Initial Weights Generated by Genetic Algorithm, *European Journal of Operational Research*, 129, 2001, pp.496-517.
- [37] George A., Ucenic C., Forecasting the Wind Energy Production Using a Neuro-fuzzy Model, *WSEAS Transactions on Environment and Development*, 2, 2006, pp. 823-829
- [38] Tozan H., Vayvay O., Effects of Fuzzy Forecasting Models on Supply Chain Performance, *Advanced Topics on Fuzzy Systems, WSEAS*, 2008, pp.107-113.
- [39] Ross T. J., Fuzzy Logic with Engineering Applications, 2th ed., *John Wiley and Sons*, 2005, pp.555-567.
- [40] Hwang J., Chen S.M., Lee C.H., Handling Forecasting Problems Using Fuzzy Time Series, *Fuzzy Sets and Systems*, 100, 1998, pp.217-228.
- [41] Hecht-Nielsen R., Neurocomputing, *Addison-Wesley*, 1990.
- [42] Maduko A., Developing and Testing a Neuro-Fuzzy Classification System for IOS Data in Asthmatic Children, *Texas University Press*, 2007.
- [43] McCullough B., Pitts W., A Logical calculus of the Ideas Immanent in Nervous Activity, *Bulletin on Mathematical Biophysics*, 5, 1973, pp.115-133.
- [44] Rosenblatt F., The Perceptron: A Probabilistic Model for Information Storage and Organization in the Brain, *Psychological Review*, 65, 1958, pp.386-408.
- [45] Parker D.B., Learning Logic, Invention Report S81-64, *Stanford University Press*, 1982.
- [46] Rymelhart D., McClelland J., Paralel Distribution Processing: Explorations in the Microstructure of Cognition, *MIT Press*, 1, 1986
- [47] Jang J.S., ANFIS: Adaptive Network Based Fuzzy Interference System, *IEEE Transactions on Systems, Man and Cybernetics*, 23, 1993, pp.665-684.
- [48] Paik S.K., Analysis of the Causes of Bullwhip Effect in Supply Chain: A Simulation Approach, *George Washington University Press*, 2003