

## The Evaluation and Comparison of Stress Node on Extended Octagonal Ring Transducers by Strain Energy Theory and Finite Element Method

Sina HAGHIGHAT SHISHVAN<sup>1</sup>, R.Cengiz AKDENİZ<sup>1</sup>, Yusef ABBASPOUR GILANDEH<sup>2</sup>  
Gurdal AKKUS<sup>1</sup>

<sup>1</sup> EGE University, Faculty of Agriculture, Department of Agricultural Machinery, 35100 Bornova- İzmir-TURKEY

<sup>2</sup> Mohaghegh Ardabili University, Faculty of Agriculture, Department of Agricultural Machinery, Ardabil-IRAN  
haghighatsina@yahoo.com

Received (Geliş Tarihi): 09.05.2011

Accepted (Kabul Tarihi): 09.07.2011

**Abstract:** The extended octagonal ring transducer generally are used in studies of agricultural engineering, particularly in the study of the forces and moments acting on soil engaging implements. The extended octagonal ring transducer provides simultaneous monitoring of the horizontal and vertical force components and the moment in the plane of these forces. The essential principle of an extended octagonal ring transducer is that when horizontal and vertical forces and moment are applied to a ring there are stress nodes which can be used as a basis for independent force component measurement with appropriately mounted strain gauge bridges. The two force components need to be measured with minimum cross sensitivity. In this study, in order to estimate the stress nodes locations and calculating the strain distribution on the extended octagonal ring transducer to identify optimal strain gage locations and reduce cross sensitivity the strain energy theory and linear elastic finite element analysis were used and the results were compared. The strain gauges location estimating by means of strain energy theory was selected according to a program which was constructed in MATLAB for Mclaughlin equations and in the case of finite element method, the ANSYS 12 finite element package was used to generate a mesh of SOLID187 type elements for the extended octagonal ring transducer.

**Key words:** Extended octagonal ring transducer, strain energy theory, finite element analysis, stress node

### INTRODUCTION

The octagonal ring transducers using strain gauge sensing elements were first reported in the literature in studies of the forces acting upon machine tool cutting elements. They have been applied in recent years in research in agricultural engineering, particularly in the study of the forces and moments acting on soil engaging implements (Dogherty, 1996).

The extended octagonal ring transducer offers a high ratio of sensitivity to stiffness, compactness and simple mounting. Also, the extended octagonal ring transducer has been claimed to be the most suitable and robust transducer due to its capability of independently measuring forces in two dimensions and resultant moment in the plane of these forces, simultaneously.

The essential principle of a ring transducers is that when horizontal and vertical forces and moment are applied to a ring, there are stress nodes which can be

used as a basis for independent force component measurement. For example; if horizontal force is applied to the extended octagonal ring transducer, there are zero bending moments in the ring at angles  $\phi$ , resulting in zero stress and hence zero strain at the ring inner and outer surfaces at the section corresponding to  $\phi$ . At the same time, if vertical force is applied to the ring, this force will result in strain at these positions and if strain gauges are attached to the outer ring surface at these position in the form of wheatstone bridge, the vertical force can be measured independently of the horizontal force. Therefore, if strain gauges are mounted in these positions and connected into Wheatstone bridge configurations, the gauges at horizontal force stress nodes will measure the force  $F_x$  independently of  $F_y$  and those at vertical force stress nodes will measure the force  $F_y$  independently of  $F_x$ . The two force components need

to be measured with minimum cross sensitivity (Kheiralla et al, 2003).

Much effort has been devoted to locating the strain nodes on an extended octagonal ring transducer, and many hypotheses have been presented in the literature.

Cook, Loewen and Rabinowicz presented generalized strain and displacement formulas for plain ring transducers in order to estimate dimensions and nodes location of transducers by using photo elasticity method.

However, the design formulas of plain extended ring transducers can not represent that of extended octagonal ring transducers, O'Dogherty, Godwin and Thakur used the design formulas by Loewen, Cook and Rabinowicz for the development of their extended octagonal ring transducers (Kheiralla et al, 2003).

Hoag and Yoerger presented a complete analytical solution based on strain energy for strain distribution in the rings of an extended ring transducer with rings of uniform thickness. They formulated equations for determination of vertical displacements, horizontal displacements, bending moments and other design considerations.

However, analytical solutions are not available for strain distribution in the extended octagonal ring transducer with ring sections of varying thickness, the bending moment and strains in the ring sections of the extended octagonal ring transducers were estimated using the equations developed by Hoag and Yoerger.

Consequently, many researchers have used the Hoag and Yoerger equations as a first approximation of strain distribution in an extended octagonal ring transducer. This along with experimental data has yielded several estimates of the optimum locations for strain gages (Chen et al., 2007).

McLaughlin noted some typographical errors in the Hoag and Yoerger equations and presented corrected equations (McLaughlin, 1996).

$$M_{\varphi} = \frac{F_x R}{2} \left( \frac{2}{\pi} - \sin \varphi \right) + \frac{F_y R}{2} \cos \varphi - \frac{M_o \left\{ \left( 2 + \frac{\pi R}{2l} \right) - \left[ \left( \frac{2R}{l} + \pi \right) \sin \varphi \right] \right\}}{\left( 8 + \frac{\pi R}{l} + \frac{2l\pi}{R} \right)}$$

$\Rightarrow$  for..... $0 < \varphi \leq \pi$  (1)

$$M_{\varphi} = \frac{F_x R}{2} \left( \frac{2}{\pi} + \sin \varphi \right) - \frac{F_y R}{2} \cos \varphi + \frac{M_o \left\{ \left( 2 + \frac{\pi R}{2l} \right) + \left[ \left( \frac{2R}{l} + \pi \right) \sin \varphi \right] \right\}}{\left( 8 + \frac{\pi R}{l} + \frac{2l\pi}{R} \right)}$$

$\Rightarrow$  for..... $\pi < \varphi \leq 2\pi$  (2)

$$\varepsilon_{\varphi} = \frac{6M_{\varphi}}{Ebt^2} \quad (3)$$

Where,  $M_o$  is the applied external moment in Nm,  $\varphi$  is the angle measured from the x-axis with positive angles counter clockwise from the left side of the ring in radians, R is the mean radius of the ring measured to the centroidal axis of the cross section in mm, and L is one half distance between ring centres in mm. In these equations, all forces applied on the left hand side (implement side) of the extended octagonal ring transducers. The sign convention employed is positive horizontal load,  $P_x$  compresses the ring; positive vertical load,  $P_y$  is upward; positive moment,  $M_o$ , is counter clockwise, and positive ring bending moment,  $M_{\varphi}$  tends to open or increase the radius of curvature of the rings.

There was agreement that gauges for horizontal force should be located at 90, but various locations for the strain nodes for vertical force were given in the literature through different researchers. For instance, O'Dogherty (1975) and Gu et al (1993) suggested 45°, Leonard (1980) and McLaughlin et al (1998) recommended 50°, and Godwin (1975) proposed 56° in order to locate strain gauges for vertical force measurement (Chen et al., 2007).

The gauge locations were selected according to strain energy theory at node angles of 90° and 39.6° for the measurement of the horizontal force and vertical force, respectively (Kheiralla et al, 2003).

## MATERIALS and METHODS

In this study, the dimensions of the extended octagonal ring transducer were designed based on transducer operation condition and analytical equations derived by cook and rabinowicz. Therefore, we have:

$$K = \frac{L}{r} = 1.6 \quad (4)$$

$$M_s = \frac{\varepsilon E b t^2}{M_o} = 0.4 \quad (5)$$

In this method, the extended octagonal ring transducer was design and constructed by taking into consideration of (K) stiffness of 1.6 which provided a (Ms) moment sensitivity of 0.4 and design loads on the ring.

$$P_x = -38.625 \text{ kN}$$

$$P_y = -23.17 \text{ kN}$$

$$M_o = 3.384 \text{ kN.m}$$

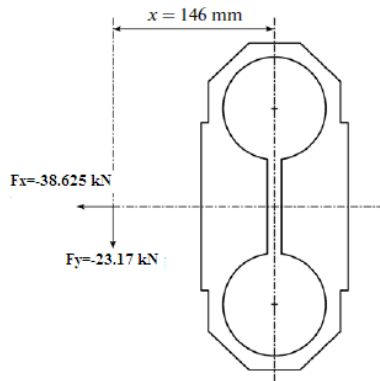

Figure 1. Forces on extended octagonal ring transducer

The material selected for the design of the extended octagonal ring transducers was mild steel 1030 AISI having yield stress of 235 Mpas and modulus of elasticity of 207 Gpas.

Also, a maximum design strain of  $1500 \mu\text{m}^{-1}$  was set as a practical design limit, as recommended by Measurement Group and used by McLaughlin et al to ensure long fatigue life of the strain gages and bonding cements (Chen et al., 2007).

So, major dimension of extended octagonal ring transducer is shown in, Fig. 2.

As discussed, the essential principle of an extended octagonal ring transducer is that when horizontal and vertical forces and moment are applied to a ring there are stress nodes which can be used as a basis for independent force component measurement with appropriately mounted strain gauge bridges. The two force components need to be measured with minimum cross sensitivity. Hence, in order to eliminate cross sensitivity, accurate locating of strain nodes is necessary.

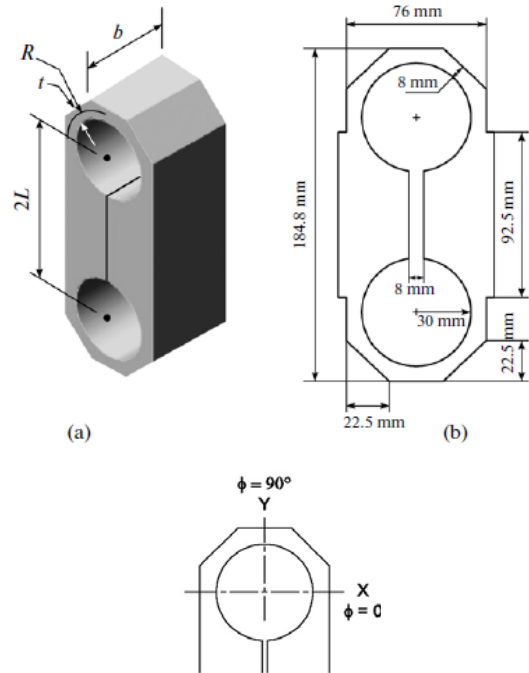

Figure 2. Major dimension and direction of extended octagonal ring transducer

The present work is a follow-up to the previous efforts on estimating the stress nodes locations and calculating the strain distribution on the extended octagonal ring transducer to identify optimal strain gage locations and reduce cross sensitivity. Therefore, the strain energy theory and linear elastic finite element analysis were used and the results were compared.

### Strain energy theory analysis

The strain energy theory and bending moment equation presented by Mclaughlin (1996) were applied in order to determine the strain nodes locations on the extended octagonal ring transducers for installing strain gauge.

In this study, the strain gauges location was selected according to a program which was constructed in MATLAB about Mclaughlin equations.

According to extended octagonal ring transducer's operation condition in this study, external applied moment expected on the external octagonal ring transducer imposed through the vertical force which applied on the transducer. The horizontal force had no effect on the external applied moment. So, the

bending moment  $M\phi$  at angle  $\phi$ , was a function of  $F_x$  and  $F_y$ .

Therefore, a program was constructed on MATLAB software that was able to present the bending moment  $M\phi$ , in the form of two independent sector  $M\phi(F_x)$  and  $M\phi(F_y)$  at angle  $\phi$  on the extended octagonal ring transducer.

$$M_{\phi}(F_x) = \frac{F_x R}{2} \left( \frac{2}{\pi} - \sin \phi \right)$$

$$M_{\phi}(F_y) = \frac{F_y R}{2} \cos \phi - \frac{146 F_y \left\{ \left( 2 + \frac{\pi R}{2l} \right) - \left[ \left( \frac{2R}{l} + \pi \right) \sin \phi \right] \right\}}{\left( 8 + \frac{\pi R}{l} + \frac{2l\pi}{R} \right)}$$

$\Rightarrow \text{for } \dots\dots\dots 0 < \phi \leq \pi$  (6)

$$M_{\phi}(F_x) = \frac{F_x R}{2} \left( \frac{2}{\pi} + \sin \phi \right)$$

$$M_{\phi}(F_y) = -\frac{F_y R}{2} \cos \phi + \frac{146 F_y \left\{ \left( 2 + \frac{\pi R}{2l} \right) + \left[ \left( \frac{2R}{l} + \pi \right) \sin \phi \right] \right\}}{\left( 8 + \frac{\pi R}{l} + \frac{2l\pi}{R} \right)}$$

$\Rightarrow \text{for } \dots\dots\dots \pi < \phi \leq 2\pi$  (7)

Only the tangential strains are of interest as a strain gage measures strain parallel to the surface it is installed on. Therefore, tangential strain can be calculated by substitution of  $M\phi$  values in the  $\epsilon_{\phi}$  equation.

$$\epsilon_{\phi} = \frac{6M_{\phi}}{Ebt^2} \quad (8)$$

Therefore, optimal locations for strain gauges, were selected on the ring based on the analysis results of the MATLAB program. Hence, the gauge locations were selected according to strain energy theory at node angles of  $90^\circ$  and  $39.54^\circ$  for the measurement of horizontal force and vertical force, respectively.

### Finite element method analysis

Linear elastic finite element analysis was used to identify the optimal strain nodes locations on the extended octagonal ring transducer.

In order to generate a mesh of SOLID187 type elements for the extended octagonal ring transducer, the ANSYS 12 finite element package was used. The SOLID187 element is a higher order 3D, 10-node

element. Also, SOLID187 has quadratic displacement behaviour and is well suited to model irregular meshes.

The loads,  $P_x = -38.625$  kN and  $P_y = -23.17$  kN, were applied separately to the left side of the extended octagonal ring transducer. Loads were applied on the nodes over an area of 92.5 mm wide along the width of the ring at the centre of the left section of the ring. This was to represent the width of the implement mounting bracket attached to the extended octagonal ring transducer. As the other site of extended octagonal ring transducer is generally fixed in applications, the fixed boundary condition (displacement = 0 in all directions) was imposed on an area of 92.5 mm along the width of the extended octagonal ring transducer at the centre of the right section of the ring. The moment was ignored in the finite element analysis.

From the finite element method analysis, the strain distribution in the extended octagonal ring transducer shows strains in the horizontal ( $\epsilon_x$ ) and vertical ( $\epsilon_y$ ) directions.

However, as a strain gage measures strain parallel to the surface it is installed, only the tangential strains on the extended octagonal ring transducer are of interest. Tangential strain can be calculated from the strains in the x and y directions using the well known strain transformation equation:

$$\epsilon_t = \frac{\epsilon_x + \epsilon_y}{2} + \frac{\epsilon_x - \epsilon_y}{2} \cos 2\theta + \frac{\gamma_{xy}}{2} \sin 2\theta \quad (9)$$

where  $\theta$  is the angle between the x-axis and the surface that the strain gage is installed on. Strain transformation equation uses the standard convention for angles with positive angles measured counter clockwise from the x-axis. To calculate tangential strain at a point on the inner surface of the ring, set  $\theta = \phi - 90$  in strain transformation equation. For the outside surface, the angle  $\theta$  is  $90$  and  $-90$  for the left and right vertical surfaces, respectively,  $45$  and  $-45$  for the left and right inclined surfaces, respectively, and  $0$  for the horizontal surface at the end of the EOR. At  $\phi = 0$  or  $180$  for both inside and outside surfaces, boundary conditions require that the shear strain,  $\gamma_{xy}$  is zero, and the tangential strain,  $\epsilon_t$  is equal to the vertical strain,  $\epsilon_y$ . Similarly, at  $\phi = 90$ ,  $\gamma_{xy}$  is zero and  $\epsilon_t$  is equal to the horizontal strain,  $\epsilon_x$ .

So, four optimal locations for strain gages were selected on the ring based on the finite element analysis results.

The location of the strain gage 1 for  $F_x$  measurement was at  $\varphi=79.5^\circ$  outside the circumference. Similarly, the location of the strain gage 2 for  $F_x$  measurement was at  $\varphi=75^\circ$  on the inside circumference.

For  $F_y$  measurement, strain nodes were identified at  $\varphi = 18.5^\circ$  and  $161^\circ$  outside the circumference, but it was decided to install strain gages inside the circumference because these locations are near the crest of the outside circumference, which implies difficulties in installing strain gages.

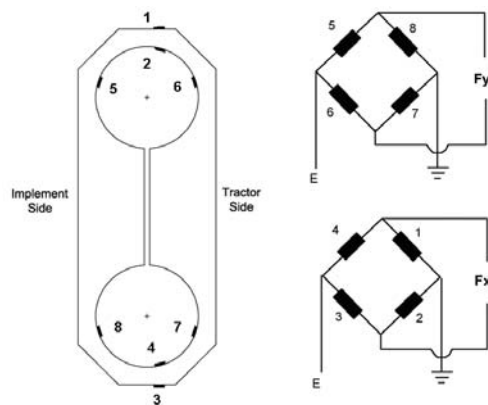

Figure 3. Strain gage positions and Wheatstone bridges on the extended octagonal ring transducer

## RESULTS and DISCUSSION

Based on the data obtained from the MATLAB program and finite element method, the strain nodal

## REFERENCES

- Chen, Y., N.B. McLaughlin, S. Tessier, 2007. Double Extended Octagonal Ring (DEOR) Drawbar Dynamometer. *Soil & Tillage Research. Res.* 93: 462-471.
- Godwin, R.J., 1975. An Extended Octagonal Ring Transducer for Use in Tillage Studies. *Journal of Agricultural Engineers Research. Res.* 20: 347-352.
- Kheiralla, A.F., A. Yahya, M. Zohadie, W. Ishak, 2003. Design and Development of Three-Point Auto Hitch Dynamometer for an Agricultural Tractor. *AJSTD.* 20(3&4): 271-288.
- McLaughlin, N.B., 1996. Correction of an Error in Equations for Extended Ring Transducers. *Trans. ASAE* 39: 443-444.
- O'Dogherty, M.J., 1996. The Design of Octagonal Ring Dynamometers. *Journal of Agricultural Engineers Research. Res.* 63: 9-18.

points for specification of the location of strain gauges on the extended octagonal ring transducer were determined.

From the results of strain energy theory, strain gauge were installed at the angle of  $90^\circ$  and  $39.54^\circ$  for independent measurement of  $F_x$  and  $F_y$  loads, respectively.

Also, as a result of the finite element analysis, strain gage locations were different from those which obtained from strain energy theory. The gauge locations were selected according to finite element analysis at node angles of  $79.5^\circ$  outside the circumference and  $75^\circ$  on the inside circumference for the measurement of the horizontal force and for vertical force measurement, strain nodes were identified at node angles of  $18.5^\circ$  and  $161^\circ$  inside the circumference.

As it is seen from the results, the node location from each method is different from the other. Such strain gage locations which were obtained from the finite element analysis will minimize the cross sensitivity effects. These locations are expected to result in reduced cross sensitivity in measuring  $F_x$  when compared to the strain gage location of  $90^\circ$  commonly used for extended octagonal ring transducer in the past. Furthermore, better mechanical protection is provided for strain gages located on the inside circumference of the ring than for those located on the outside surfaces of the ring.

The estimation of stress nodes by using strain energy theory has only one advantageous. If anyone uses this method, the strain gauges mounting will be so easy than other method.