

A Microcontroller-Based Data Logging System for Cone Penetrometry

**Mojtaba NADERI-BOLDAJI^{1*}, Reza ALIMARDANI¹, Ahmad SHARIFI²,
Ahmad TABATABAEFFAR¹**

¹Department of Agricultural Machinery Engineering, Faculty of Biosystems Engineering,
University of Tehran, Karaj, Iran

²Agricultural Engineering Research Institute (AERI), Karaj, Iran

*Corresponding author: m.nadery_boldaji@yahoo.com

Abstract: High soil strength has been shown by many researchers to be a significant soil physical property that reduces crop yields. A fast and yet accurate method of determining whether this problem exists in a particular soil is needed for tillage practices and for studies involving yield trails. A Microcontroller-Based Data Logging System (MBDLS) was designed and developed for collecting, monitoring, saving and processing penetration data with a tractor-mounted penetrometer. An AVR microcontroller was employed for this purpose. The software was developed with CODE VISION AVR and standard C language. To eliminate the errors in designing the system circuitry, the PROTUES software was utilized and for final print of optimized circuit, the PROTEL DXP-2004 was employed. The instrumentation is powered from the tractor's battery. Force and depth signals are generated by a cantilever beam strain-gage load cell and a photodiode sensor, respectively installed on the penetrometer unit and sent to the MBDLS. A serial RS-232 cable transfers the data to a PC. The system can save data related to 300 insertions to a depth of 60 cm in memory. Soil bin test was conducted to evaluate the system. The system performance was found to be reliable and the electronic parts worked without any malfunctions. The device is very economical and easy to use.

Key words: Data logging system; Microcontroller; Cone index; Strain gage; Photodiode sensor

INTRODUCTION

In agricultural systems, the risk of soil compaction increases with the growth of farm operations and the drive for greater productivity causing farmers to use heavier machinery. It adversely affects soil structure, reduces crop production, increases runoff and erosion, accelerates potential pollution of surface water by organic waste and applied agrochemicals, and causes inefficient use of water and nutrients due to slow drainage (Hemmat and Adamchuk, 2008).

High bulk density and strength of soil have been shown to be a significant soil physical property that reduces crop yields. A fast and reproducible system for determining soil strength is needed for tillage and research involving yield trails. Cone index is a relative measure of soil strength defined as force per unit base area of a circular cone required to penetrate the cone through a small increment of soil expressed in MPa (ASAE Standard S313.3, 2006). Strong correlations have been shown to exist between cone index and root penetration and elongation, off-road

vehicle trafficability, soil hydraulic conductivity, and some of the other soil parameters (Riethmuller et al., 1983).

Electric cone penetrometers were first developed in Holland in 1965 (Jaksa and Kaggwa, 1994). At that time, measurements of cone tip resistance and sleeve friction were recorded using analogue instruments. De Ruiter (1971) detailed one of the first data logging systems consisted of a Wheatstone bridge instrument which records load variations directly as a continuous graph. Depth of the cone penetrometer was measured by a magnetic reduction coupling installed between the loading frame which is connected to the push rods and the transport mechanism of the chart recorder. In this way, the chart paper advanced 1 mm for every centimeter of cone penetration.

Several improvements have been made with respect to the recording of cone penetrometer data. Prather et al., (1970) developed a hand-operated penetrometer, which measures force and depth

electronically and provides an X-Y plot of force versus depth. Williford et al. (1972) and Smith and Dumas, (1978) also used X-Y plotter in their tractor-mounted penetrometers. X-Y plotters require frequent calibration, and processing data from X-Y plots is a very time-consuming task. Carter (1969) developed a penetrometer which utilizes a dc operational amplifier circuit to provide a voltage signal proportional to the average penetration force for a given depth.

A microcomputer-based data logging system was developed by Riethmuller et al. (1983) for a tractor-mounted penetrometer. The system was based on a ROCKWELL AIM65 microcomputer which uses a 6502 processor. The AIM 65 was selected for its keyboard, a 20 character thermal printer, and an input/output tape control. With this system, collected data could be manipulated, saved on a magnetic tape, and routed to its line printer for immediate observation. A micro logger (Campbell Scientific Inc. USA) was employed by Chi and Tessier (1995) in a portable micro-penetrometer for measuring seed row compaction by 11 load cells and one LVDT.

A data logger may be used to scan and record data from transducers in an instrumentation system. In addition, it can provide the excitation voltage for the transducers without the need of an external power supply. Many data acquisition systems to record data from the transducers using data loggers and microcomputers have been reported. In order to record the data from the strain gages or load cells suitable data acquisition systems have been designed and built for field use. A personal computer-based data acquisition system was used by Boon et al. (2005) for a tractor-mounted, automated soil penetrometer-shearometer unit for mapping soil mechanical properties. The on-board system in tractor acts as a data recording, processing, and storage center for tractor geo-position, soil penetration resistance and shear stress data. Ohmiya (1998) developed a computer-controlled cone resistance measuring system and visualization software for generating two and three dimensional cone resistance distribution maps. Gohari and Hemmat (2005) developed a laptop-based data logging system for recording penetration resistance with a GPS-tractor mounted penetrometer used in variable depth tillage system. A digital caliper and S-shaped load cell were

employed for measuring penetration depth and force, respectively.

The main objective of this task was to develop a microcontroller-based data logging system for acquiring data with a tractor-mounted penetrometer related to soil penetration resistance.

MATERIALS and METHODS

A microcontroller-based data logging system was developed for versatility in programming, low cost, high data manipulation speed and ease of interfacing with input data (Fig. 1). The instrumentation system consisted of a depth sensor, force transducer, and a data logging system based on an AVR microcontroller.

Depth Sensor

Several methods can be employed to obtain the depth signals in penetrometry. A linear variable differential transformer or a multi-turn potentiometer is used to obtain an electrical signal proportional to the penetration depth. In this study, for design of depth measuring mechanism, a different approach was undertaken by using a photodiode sensor. A 2 mm thick plate (800 x 30 mm) folded 90 degrees along the length forming L-shaped plate, a base and a guiding block form the depth measurement mechanism. On one side of L-shaped plate, forty holes (4 mm in diameter) were drilled equally with 15 mm intervals. The penetrometer cone shaft and L-shaped plate were fitted into a machined guiding block so that the guiding block could move easily. The photodiode sensor was mounted on guiding block so that the L-shaped plate can pass through the detectors (transmitter-receiver sensor set) and interrupt the ultra-red rays passing from transmitter to detector. The number of output pulses of the detector is a representative of depth (each pulse as 15 mm of depth). The maximum depth of penetration is 600 mm. Input voltage of the photodiode is 3 V provided by a regulator fed from battery of tractor. This device for depth measurement is very precise and low cost.

Force Transducer

The force on the penetrometer is measured using a temperature compensated cantilever beam strain gage load cell. The maximum load is 2.2 kN with a

50% peak safe overload of 3.3 kN. The hydraulic cylinder oil pressure is regulated to 7 MPa (read on a pressure gage) so as to not allow the force greater than 2.2 kN. With this pressure, the maximum measurable cone index is nearly 7 Mpa which is usually sufficient enough even in most hardpan soil conditions. However, the system can measure the cone index up to 10 MPa. Typical values of cone index that stop root growth are near 2 MPa (Price and Throit, 2003). If this maximum allowable force is not enough for a particular soil condition, then a cone with lower diameter can be used. Input voltage of the Wheatstone bridge is 5 V powered by regulating the voltage of tractor's battery.



Fig. 1. Microcontroller-based data logging system

Data Logging system

The developed data logging system (MBDLS) consists of an AVR microcontroller, a 256 KB EEPROM, a 40-column with 4-line monochrome LCD display with blue background, a 16-key keyboard and an RS-232 serial port. The components of MBDLS were installed on a 15×20 cm circuit board (Fig. 1). The developed integrated MBDLS is placed in front of operator and powered from tractor's battery. A block diagram of the system is shown in Fig. 2.

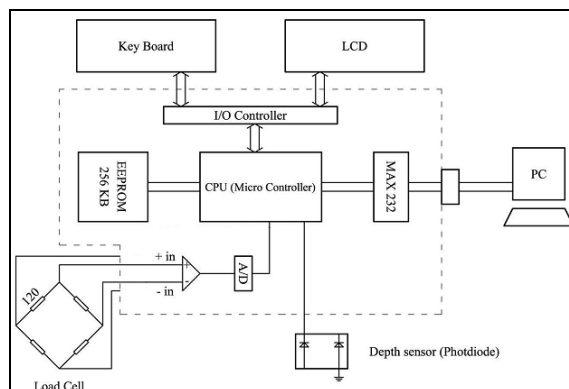

Fig. 2. Block Diagram of the Data Logging System

The heart of the MBDLS is an 8 bit-16 MHz AVR microcontroller model ATMEGA 32 provided by ATMEL Company. The features of this microcontroller are; 32 KB of In-system programmable flash memory, 1024 bytes of EEPROM, 2 KB SRAM, 32 general purpose I/O lines, 8-channel, and 10-bit A/D converter.

The keyboard consists of 10 numeric keys and 6 function keys (SET, ENTER, F1, F1, F3 and F4). Four LED indicators above the keyboard show the operating status of the system. These statuses are ON/OFF, ready to work, data collection and data transmission.

In cases that the speed of data transfer is low, serial EEPROMs is better than parallel EEPROMs. In addition, when design of a board with small dimensions is desirable, serial EEPROMs is more adequate. Therefore, a 256 KB EEPROM (ATMEL) with high performance and low power requirement was employed in this system. The required input voltage is 3 to 3.6 V that is proper for portable systems fed by battery.

The PROTEL- DXP-2004 software was employed for design of circuit board on a two layer-metalized electronic board. The LCD and keyboard were mounted on this board to make a compact and portable data logging system. To eliminate the noise effects on the board, power-plain were used and connected to ground terminal. Also, for elimination of noise interrupting the sensor signal, shielded wires were used. In design process, no variable-resistor was employed to avoid the error encountered by temperature variation.

Software

The software developed for the data logging system is a compiler version 1.0.2.1-CODE VISION AVR written with C-standard language. All functions were written in separate added files. The functions allow the entrance of decimal numbers with positive and negative signs. The software also provides the features of prompts to user and selected options. The auxiliary memory is a 256 KB EEPROM in which data and commands are passed via a two-wire interface protocol provided by Philips-12C (Philips, USA). This allows the programmer to have random access to all points of memory in order to do a function task. These functions are designed so that in every task, only 10 bytes of memory is occupied in the way that Julian date, field number, block number depth and load cell output signals each occupies two bytes.

In order to record data, parameters are in the form of structure and saved in blocks of the memory. The advantage of this method is ease of understanding the software operation. For number of pulses received from photodiode sensor, the external interrupt of microcontroller is used. At this section, a software filter is set to reduce the undesirable noises caused by tractor vibration and magnetic field of tractor's alternator. In this way, the interrupts and counts take place when real pulses are received from sensor. The PROTUS – VSM was employed for software simulation. Therefore, most of the errors were eliminated before final design. Also, from output investigation of simulator, most of unpredicted cases that might occur during operation are anticipated in the software and therefore were eliminated.

Load Cell Data Acquiring

Since the circuit of load cell is composed of four strain gages in a Wheatstone bridge configuration, the output of load cell is in the form of positive and negative signals in accordance to force direction. So, the A/D converter has two positive and negative inputs. Therefore, the differential system in the A/D converter is activated and two base pins of microcontroller are reserved for transducer's output. With regard to the sensitivity of system and very low output voltage of the load cell, the microcontroller's amplifier is turned on and its gain factor is determined by software. The default gain factor is 200. But this

gain factor causes an increased noise over the system. To eliminate the noises, all the operations during sampling with A/D are stopped (including CPU). In this status, after sampling and digital conversion of signals, the system is reset back to its original case. Also for recording, an average of 200 data points is saved as final data with a speed of 1 KHz.

A computer interface program was written with Visual Basic Version 6.0 to upload the data from system memory into a computer. The data consisted of replications, date, field number, block number, depth and pressure are shown in six columns. Also the calibration formula for load cell is shown beneath the columns.

System Operation

After the data logging system is powered on, four labels of ON/OFF, MEMORY, RUN and OPTION are displayed on the LCD panel. By pressing the OPTION key information such as date, field number, block number, calibration formula for the load cell in the format of AX+B, depth measurement (number of holes and their interval on depth index), gain factor of amplifier is asked to bring the system into ready mode. These options are arbitrary to select. By pressing RUN key, system is ready to collect data from depth sensor and load cell. At this time, operator pushes the cone tip into the soil by hydraulic system of tractor. Depth mechanism is designed so that as the base of cone is reached the soil surface, a pulse introducing the zero depth is sent to data logger system. During data collection, location of depth and value of pressure applied is displayed. When the cone is reached to desired point, system prompts a question for saving data. By pressing YES key, data is stored. In the case, that cone tip is in contact with obstacle, the hydraulic system stop pressing the cone tip and data is discarded by selecting the EXIT key. The memory of the system is capable of saving 300 measurements up to depth of 600 mm. After ending data collection in the field, through an RS-232 cable, data are uploaded into a computer by interface software PENETROMETER DATA RECORDER (PDR) written with Visual Basic V6.0 program language. By pressing the MEMORY button and then EXPORT button, data is dumped as an EXCEL file. Also by

pressing MEMORY and then READ button, the saved data and free spaces are displaced. The ERASE button from MEMORY option would cause the data to be erased.

SYSTEM PERFORMANCE

To evaluate the performance of MBDLS, several laboratory tests were conducted by comparison of the data obtained by a developed hand-pushed penetrometer (with instrumentation system similar to that of tractor mounted penetrometer) with those of a commercial hand-pushed Eijkelkamp (Model 06.15 Netherlands) penetrometer.

Soil Bin Tests with a Developed Hand-Pushed Penetrometer

Since there was no standard tractor-mounted penetrometer in access for comparison, a hand pushed-penetrometer with measurement system similar to tractor-mounted penetrometer was designed and fabricated as a portable instrument that can be used by the MBDLS. The evaluation of the penetrometer unit was performed in the soil bin of agricultural engineering research institute (AERI) located in Karaj-Iran. The soil of the soil bin was found as a clay-loam with moisture content of 12%. The soil was prepared with compacted layers in the middle depth of 10-20 cm by a soil processor unit. The developed and commercial hand-pushed penetrometers were used in soil bin tests. The commercial penetrometer has an S-shape load cell for measuring the penetration force and an ultrasonic sensor for determining the depth.

In the soil bin, soil penetration resistance measurements were made with both developed and commercial hand-pushed penetrometers. Twenty-eight locations along the 14 m plot with interval of 0.5 m were selected for data collection by two penetrometers. The measurements by the developed penetrometer were made with a lateral distance of 10 cm relative to the points measured by commercial penetrometer. Two penetrometers had a 30 degrees cone angle and equal cone shaft diameter during the experiments.

RESULTS and DISCUSSIONS

The averaged cone index measurements recorded by the data logging system for both the developed hand-pushed penetrometer and Eijkelkamp penetrometer tested in soil bin, were plotted for the depth to 550 mm (Fig. 3).

Statistical analysis (t-test) was used for comparison of data obtained by the two hand-pushed penetrometers in soil bin for soil cone index values. The results of F-test showed no significant difference ($p > 0.01$) between the variances of two variables. Since the data samples have equal variances, the t-test analysis was run assuming equal variance. The presence of no differences ($p > 0.01$) between the data obtained from the tests led to conclude that the soil cone index measurements for both hand-pushed penetrometers were similar as shown in Fig. 3. The soil compaction profiles plotted for two penetrometers are similar. Also, the agreement between the two penetrometers was high with correlation coefficient of 0.997 and a slope close to one with an almost zero-intercept. In order to verify the cone index values measured by a bevameter, Garciano et al. (2006) compared the instrument with a commercially available cone penetrometer. They found a high correlation between two penetrometers with coefficient of correlation of 0.970.

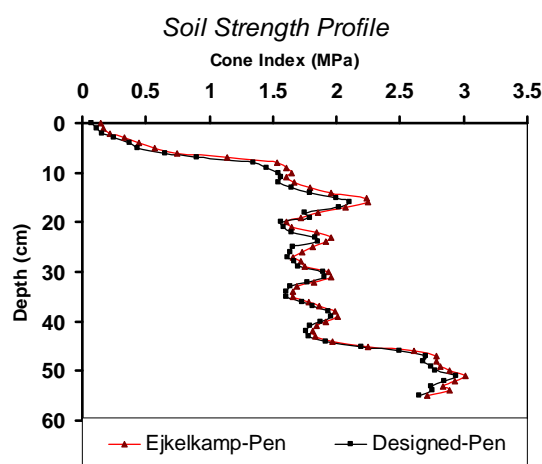

Fig. 3. Average soil strength profile for the hand-pushed penetrometers

CONCLUSIONS

A microcontroller-based data logging system was developed and used to record and display depth and cone index for both tractor-mounted and hand-pushed penetrometers. Depth and force signals were generated by a photodiode and load cell, respectively. The analogue data inputs were converted to digital and saved in the memory of the system for further processing. The use of an electronic data logging soil penetrometer made it possible and convenient to gather digitized soil resistance data. The microcontroller-based data logging system was designed and developed for measuring, displaying, and acquiring the soil penetration resistance in real time. The system tested in this study has been proven good and can be used for acquiring and evaluation of

soil strength, trafficability predictions, and soil compaction. The data storage capacity of the system is approximately 300 insertions up to 55 cm of depth. The required measurement depth determines the number of test data sets that can be stored on the data logger. The system is low cost and accurate as well as easy to use by one individual.

ACKNOWLEDGMENT

The authors gratefully acknowledge the technical guidance of Iranian Agricultural Engineering Research Institute (IAERI) and financial supports of National Elites Foundation (Bonyade Melli-e Nokhbegan) and University of Tehran that provided for me the possibilities to participate in this congress.

REFERENCES

- ASAE standards. ASAE Standard S313.3, 2006. Soil cone penetrometer. ASAE St. Joseph, MI 49805.
- Boon, N.E., A. Yahya, A.F. Kheiralla, B.S. Wee, S.K. Gew, 2005. A tractor-mounted, automated soil penetrometer-shearometer unit for mapping soil mechanical properties. *Biosystems Engineering* 90: 381-396.
- Carter, L.M., 1969. Integrating penetrometer provides average soil strength. *Agricultural Engineering* 50: 618-619.
- Chi, L., S. Tessier, 1995. A portable micro-penetrometer for measuring seed row compaction. *Soil & Tillage Research* 34: 27-39.
- De Ruiter, J., 1971. Electric penetrometer for site investigations. *Journal of Soil Mechanics & Foundations Div, ASCE*, 97: 457-472.
- Garciano, L.O., S.K. Upadhyaya, R.A. Jones, S.R. Jersey, 2006. Development of an instrumented device that measures shear, sinkage and friction properties of soil in-situ, ASAE Meeting Paper No: 061093, St. Joseph.
- Gohari, M., A. Hemmat, 2005. A tractor-mounted soil cone penetrometer for mapping spatial variability of soil strength. In: *International Agricultural Engineering Conference, Bangkok, Thailand*.
- Hemmat, A., V.I. Adamchuk. 2008. Sensor systems for measuring soil compaction: Review and analysis. *Computer and Electronics in Agriculture* 63: 89-103.
- Jaksa, M. B., W. S. Kaggwa, 1994. A Micro-Computer Based Data Acquisition System for the Cone Penetration Test. Department of Civil and Environmental Engineering University of Adelaide. Research Report No. R 116.
- Ohmiya, k. 1998. Three dimensional cone resistance mapping: A technique for soil strength assessment. In: *International Agricultural Engineering Conference, Bangkok, Thailand*.
- Prather, O.C., J.G. Henrich, R.L. Shafer, 1970. An electronic hand-operated recording penetrometer. *Transaction of the ASAE* 13: 385-386, 390.
- Price, R.R., J. Theriot, 2003. Development of a frame to automatically insert a hand-held penetrometer. ASAE Meeting Paper No. 031077. St. Joseph. Mich.
- Riethmuller, G.P., D.G. Batchelder, P.D. Bloome, 1983. A microcomputer system for cone index measurement. *Transaction of the ASAE* 26: 996-999.
- Smith, L.A., W.T. Dumas, 1978. A recording soil penetrometer. *Transaction of the ASE* 21:12-14.
- Wilford, J.R., O.B. Wooten, F.E. Fulgham, 1972. Tractor mounted field penetrometer. *Transaction of the ASE* 15: 226-227.