

LCL Filter Design for Grid Connected NPC Type Three-Level Inverter

Sangmin Lim*, Jaeho Choi*[‡]

*School of Electrical Engineering, Chungbuk National University, 362-763, Republic of Korea

[‡]Corresponding Author: Jaeho Choi, 1 Chungdae-ro, Seowon-gu, Cheongju, Chungbuk, 362-763, Republic of Korea
Tel: +82 43 261 2425, Fax: +82 43 276 7217,

E-mail: choi@cbnu.ac.kr

Received: 19.10.2014 Accepted: 18.11.2014

Abstract- This paper describes a LCL filter design method for a grid connected NPC three-level inverter. By analyzing the ripple current according to the switching of NPC three-level inverter, the inverter side inductor is designed without any information about the modulation index. After considering the relation between the inductance ratio of inverter inductor to grid inductor and the filtering effect at the switching frequency, the relation between the inductance ratio and the attenuation of output ripple, and the current ripple of inverter side inductor, the optimized value of LCL filter is designed to meet the design criteria. Finally, the proposed design method is validated through the simulation and experimental results.

Keywords- Solar energy, PCS (power conditioning system, LCL filter design, NPC three-level inverter, grid-connected inverter

1. Introduction

Researches in the area of distributed power generation system (DPGS) such as wind turbines, solar power systems, fuel cells, etc. have been increased recently [1]. DPGS is normally connected to the grid system through inverter. The output current of grid connected inverter includes higher order harmonics due to the switching of PWM inverter. Typically, L filter has been used between the inverter and the grid to suppress the current harmonics. But the cost of L filter for large power applications is very high and the system dynamic response may be slow. Comparing with L filter, LCL filter has been known to be more effective to suppress the switching harmonics, but it brings the disadvantage of generating a resonance problem. Also, the design procedure to determine the parameter values of LCL filter is complicate to consider several constraints, such as filter size, current ripple, absorbed reactive power at filter capacitor, etc. Therefore, it is important to choose appropriate parameters for LCL filter [2,3].

Recently, there have been done some researches how to design LCL filter [2-9]. In [2], the LCL filter parameters are designed by using the reactive power rate and the current ripple rate. If both of rates are not appropriately selected, it does not meet the design criteria. As a result, the system is unstable and LCL filter parameters should be designed again. In [6], the inverter side inductor and the grid side inductor are assumed to be one inductor ($L_i + L_g = L_T$) for the design. The

advantage of this design method is that the total inductance is defined firstly to meet the total inductance criteria which is different from other design. However, the formula is complex when each inductance has to be calculated. In [7], the design of the inductor to the waveform of PWM is divided into eight modes to calculate the parameter value, so the inverter side inductor can be obtained more accurately. But for the design of the inverter side inductor, three variables such as THD of inverter output current, modulation index, and grid side inductor are considered. If they are not assigned properly to formula process, there are some problems to be recalculated again [8]. In [9], to solve this problems, it determines the region satisfying the design criteria. And the LCL filter is designed considering the voltage ripple factor under the critical load and the rated power. But for the design of the inverter side inductor, it uses the switching modulation index depending on the fundamental modulation index. Then it may be difficult to design accurately without the exact information about the switching modulation index.

To improve the output power quality and to reduce the filter size, it has been used the multi-level inverter for the application of DPGS [10]. And as the increase of interests in the multi-level inverter, there have been some researches to design the LCL filter for three-level inverter [11-13]. But most of them are based on the given modulation index [11,12] or about choosing the resonant frequency of LCL filter for the application of active power filter [13].

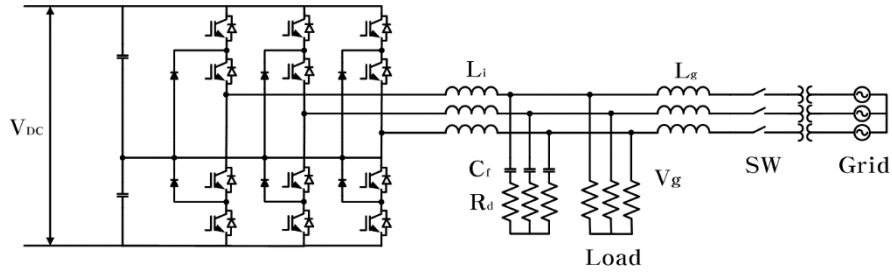

Fig. 1. Configuration of grid connected NPC type three level inverter with LCL filter.

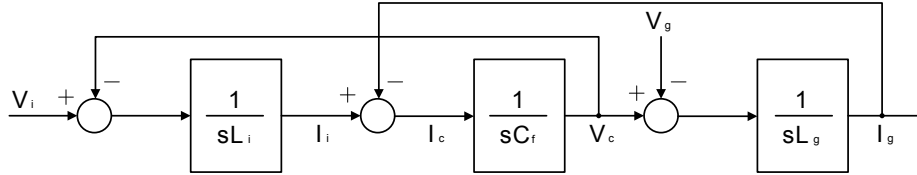

Fig. 2. System block diagram of LCL filter.

In this paper, the inverter side inductor is designed by analyzing the ripple current according to the switching of NPC type three level inverter without any information about the switching modulation index. And the design area to meet the design criteria of LCL filter is determined. In addition, by considering the relation between the filtering effect and the attenuation of output current and the inductance ratio of grid side inductor to inverter side inductor, the optimized value of LCL filter will be designed.

2. LCL Filter Design

2.1 Modeling of the LCL Filter

Figure 1 shows the configuration of grid connected NPC type three-level inverter with LCL filter. The system block diagram of LCL filter is shown in Fig. 2. From Fig. 2, the transfer function of LCL filter and its resonant frequency are given as (1) and (2):

$$G(s) = \frac{I_g(s)}{V_i(s)} = \left(\frac{1}{L_i L_g C_f} \right) / s \left(s^2 + \frac{L_i + L_g}{L_i L_g C_f} \right) \quad (1)$$

$$f_{res} = \frac{1}{2\pi} \sqrt{\frac{L_i + L_g}{L_i L_g C_f}} \quad (2)$$

2.2 Criteria of LCL Filter Design

The base impedance of system must be given for choosing the LCL filter parameters in order not to create the problems such as resonance problem, voltage drop problem and reactive power problem [8]. The base values of each component of LCL filter are defined as (3)~(5).

$$Z_b = 3V_c^2 / P \quad (3)$$

$$L_b = Z_b / \omega_1 \quad (4)$$

$$C_b = 1 / \omega_1 Z_b \quad (5)$$

The criteria of LCL filter design is described as followings:

A. The total inductance value of both inverter side inductor and grid side inductor should be lower than 10% of base inductance value to limit the voltage drop at inductors during

the operation.

$$L_T \leq 0.1L_b = \frac{3V_c^2}{10\omega_1 P} \quad (6)$$

B. The filter capacitance value should be less than 5% of base capacitance in order to limit the reactive power at the rated power.

$$C_f \leq 0.05C_b \quad (7)$$

C. The resonance frequency should be in the range between ten times of line frequency and one half of switching frequency not to generate the resonance problem.

$$10f_1 \leq f_{res} \leq (1/2)f_{sw} \quad (8)$$

2.3 LCL Filter Design

One leg of NPC type three-level inverter consists of four switching devices with anti-parallel diodes and two clamping diodes. Each clamping diode is connected to the neutral point of two DC link capacitors. The output voltage is determined according to the switching state of each phase. The pole voltage is $+V_{dc}/2$ when the upper two switches are turned on, zero when the two middle switches are turned on, and $-V_{dc}/2$ when the lower two switches are turned on. These conditions are indicated as P (positive), O (neutral-point), N (negative) and can be defined as (9).

$$S_{abc} = \begin{cases} 0.5 & \text{upper two switches are turned on} \\ 0 & \text{middle two switches are turned on} \\ -0.5 & \text{lower two switches are turned on} \end{cases} \quad (9)$$

And the switching states, the pole voltages, and the symbols are listed in Table 1 [12,13]. The offset voltage is 1/3 value of sum of pole voltage according each switching state as (10).

$$V_N = \frac{V_{dc}}{3} (S_a + S_b + S_c) \quad (10)$$

The analysis for current ripple of inverter output side is done under the assumption of inverter side inductor only for LCL filter. It is complicate to consider all PWM switching condition, so the voltage waveform is simply modified as that in the most serious situation which generates the highest ripple

Table 1. Switching state and pole voltage

SW Ftn.	S_1	S_2	S_3	S_4	Pole Vtg.	SW State
0.5	ON	ON	OFF	OFF	$+\frac{V_{dc}}{2}$	P
0	OFF	ON	ON	OFF	0	O
-0.5	OFF	OFF	ON	ON	$-\frac{V_{dc}}{2}$	N

as shown in Fig. 3(b). Figure 3 shows the waveforms of phase voltage and current.

As shown in Fig. 3, when the switching stage changes from (P,N,N) to (O,O,O), each switch changes step by step. If it is assumed that T_1 , T_2 , and T_3 in Fig. 3(a) are extremely close to be equal, it can be shown as like Fig. 3(b) simply. And then, it generates the highest current ripple at this condition, and the inverter side inductor is to be designed to suppress the current ripple at this most serious situation. Figure 4 shows the equivalent circuit for analysis in this situation

According to Fig. 4, when S_1 and S_2 are turned on, the voltage equation can be expressed as:

$$V_{dc} = L_i \frac{\Delta I}{T_{on}} + V_c + V_N$$

$$= L_i \frac{\Delta I}{T_{on}} + V_c + \frac{V_{dc}}{3} (0.5 + (-0.5) + (-0.5)) \quad (11)$$

And when S_1 is turned off while S_2 is turned on, the voltage equation can be expressed as:

$$\frac{V_{dc}}{2} = -L_i \frac{\Delta I}{T_{on}} + V_c + V_N$$

$$= -L_i \frac{\Delta I}{T_{on}} + V_c + \frac{V_{dc}}{3} (0 + 0 + 0) \quad (12)$$

The switching frequency is much higher than the grid frequency, so the grid voltage and the duty cycle can be assumed to be constant during one switching period. Hence the switching on and off time, T_{on} and T_{off} , can be expressed by using the modulation index m_a as:

$$T_{on} \approx m_a T_s \quad \text{and} \quad T_{off} \approx (1 - m_a) T_s \quad (13)$$

Combining (11), (12), and (13), the current ripple can be described as:

$$\Delta I = \frac{2V_{dc} T_s}{3L_i} (1 - m_a) m_a \quad (14)$$

The current ripple is maximum at the modulation index of 0.5, so it will be given as:

$$\Delta I = \frac{2V_{dc} T_s}{6L_i} = \frac{2V_{dc}}{6L_i f_{sw}} \quad (15)$$

and the RMS value of fundamental component of current ripple is given as:

$$I_{i,sw} = \frac{V_{dc}}{12\sqrt{3}L_i f_{sw}} \quad (16)$$

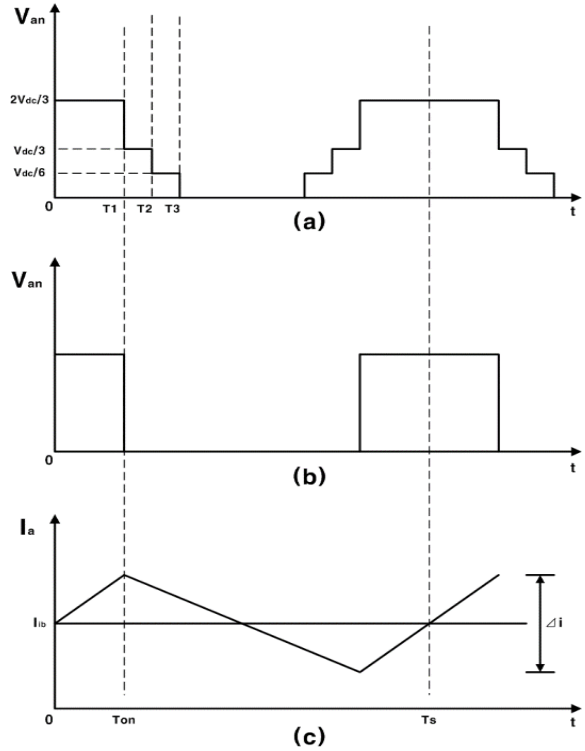

Fig. 3. Relationship between voltage and current ripple: (a) Phase voltage, (b) simplified phase voltage, (c) phase current

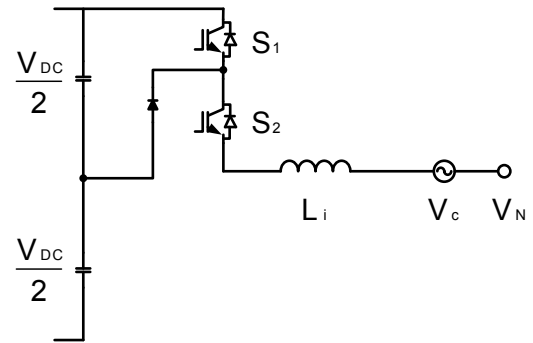

Fig. 4. Equivalent circuit of phase a under positive voltage condition.

The fundamental component of inverter output current can be expressed as:

$$I_{i,1} = \frac{P}{3V_c} \quad (17)$$

According to (16) and (17), the inverter side inductor can be described with the inverter side current ripple ratio of $r_i = I_{i,sw}/I_{i,1}$ as (18):

$$L_i = \frac{V_{dc} V_c}{4\sqrt{3} r_i f_{sw} P} \quad (18)$$

The filter capacitor and the grid side inductor can be designed by using the same method in [9]. The transfer function of the capacitor voltage ripple to the inverter voltage can be described differently for the cases of LC filter and LCL filter, but the former of which the harmonics attenuation effect is worse is considered to design the capacitor value in this work [9,13]. The system block diagram of LC filter is shown as Fig. 5.

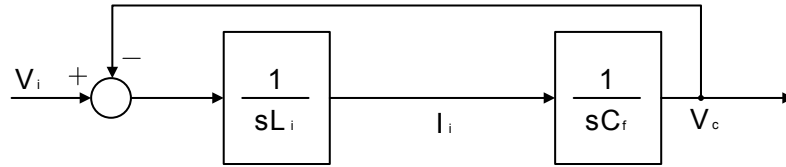

Fig. 5. System block diagram of LC filter.

$$\frac{V_{c,sw}}{V_{i,sw}} = \frac{1}{\omega_{sw}^2 L_i C_f + 1} \quad (19)$$

The harmonic component of the inverter voltage can be expressed as (20), and combining (18), (19) and (20), the filter capacitor is given with the voltage ripple ratio of $r_v = V_{c,sw}/V_{c,1}$ as (21).

$$V_{i,sw} = \omega_{sw} L_i I_{i,sw} \quad (20)$$

$$C_f = \frac{r_i P (\pi V_{dc} - 6\sqrt{3} r_v V_c)}{3\pi r_v \omega_{sw} V_{dc} V_c^2} \quad (21)$$

From Fig. 2, the ripple components ratio of grid current to inverter current can be expressed as (22), and then the grid side inductor is derived from (21) and (22) with the grid side current ripple ratio of $r_g = I_{g,sw}/I_{g,1}$ as (23):

$$\frac{I_{g,sw}}{I_{i,sw}} = \frac{r_g I_{g,1}}{r_i I_{i,1}} = \frac{1}{\omega_{sw}^2 L_g C_f + 1} \quad (I_{g,1} \approx I_{i,1}) \quad (22)$$

$$L_g = \frac{3\pi V_{dc} V_g^2 r_v (r_i - r_g)}{\omega_{sw} r_i r_g P A} \quad (23)$$

2.4 LCL filter design area to meet design criteria

Substituting (18) and (23) into the criterion of total inductance in (6), the first range of the inverter side current ripple ratio, r_i , is given as (24):

$$r_i \geq \frac{5\pi\omega_1 r_g V_{dc} (\pi V_{dc} - 12\sqrt{3} r_v V_c)}{3\sqrt{3} V_c (\omega_{sw} r_g (\pi V_{dc} - 6\sqrt{3} r_v V_c) - 10\pi\omega_1 r_v V_{dc})} \quad (24)$$

Substituting (22) into the criterion of filter capacitance in (7), the second range of r_i is given as (25):

$$r_i \leq \frac{0.05\pi\omega_{sw} r_v V_{dc}}{\omega_1 (\pi V_{dc} - 6\sqrt{3} r_v V_c)} \quad (25)$$

And substituting (18), (21), and (23) into the criterion of resonance frequency in (8), the third range of r_i , is given as (26):

$$\frac{r_g (1.25\pi V_{dc} - 15\sqrt{3} r_v V_c)}{0.25\pi V_{dc} - 7.5\sqrt{3} r_v V_c} \leq r_i \leq \frac{r_g \{ \omega_{sw}^2 (\pi V_{dc} - 12\sqrt{3} r_v V_c) + 100\omega_1^2 (\pi V_{dc} - 6\sqrt{3} r_v V_c) \}}{100\omega_1^2 (\pi V_{dc} - 6\sqrt{3} r_v V_c) - 6\sqrt{3} r_v V_c} \quad (26)$$

The voltage ripple ratio should be less than 0.03 according to regulations of IEEE 519 [14]. And grid current ripple ratio at the switching frequency of 10kHz should be less than 0.003 according to the regulation of IEEE 1547 [15].

The LCL filter parameters are designed according to the voltage ripple ratio, r_v and the current ripple ratio, r_i . Table 2 shows system parameters. The appropriate region for r_v and r_i can be derived to meet the design guide line as the shade region shown in Fig. 6. In Fig. 6, the right side of the dotted line represents (24), the left side of dot-and dash line represents (25), and the region between two solid lines

represents (26), respectively. And also, the region under the x and dash line represents the regulation of IEEE 519.

Table 2. System parameters

System parameters		
Power (P)	5	kW
DC Voltage (V_{dc})	400	V
Capacitor Voltage (V_c)	127	V
Switching Freq. (f_{sw})	10	kHz
Grid Freq. (f_1)	60	Hz

Table 3. LCL parameters for three different cases in Fig. 6

Parameters	Case 1	Case 2	Case 3
r_i	0.07	0.15	0.2383
r_v	0.011	0.0294	0.0294
L_i [mH]	2.1	1	0.59
L_g [mH]	0.55	1.4	1.6
C_f [uF]	11	8	13
f_{res} {Hz}	2,299.7	2,330.9	2,127.1
A	0.26	1.4	2.7
THD _i [%]	1.9	1.7	1.6

As examples of filter design, three cases in Fig. 6 are considered to analyze the filtering performances as shown in Table 3 with different LCL parameters, resonance frequencies, and THD_i values.

Although the LCL filter parameters satisfy all design criteria, but the parameter values are all different in each case, and also the THD_i values of LCL filter output current are also different. In each case, it can be considered the filter transfer function and the suppression ratio of the filter output current as the inductance ratio of grid to inverter inductor which is given as shown in (31).

$$L_g = aL_i, \quad L_i = \frac{1}{a+1} L_T, \quad L_g = \frac{a}{a+1} \quad (27)$$

Substituting (27) into (1), the gain value of LCL filter transfer function at switching frequency can be represented as in Fig. 7.

As shown in Table 3 and Fig. 7, the value of total inductance is largest but the output current THD_i is the highest in case 1.

And also, the filter effect will be changed radically even

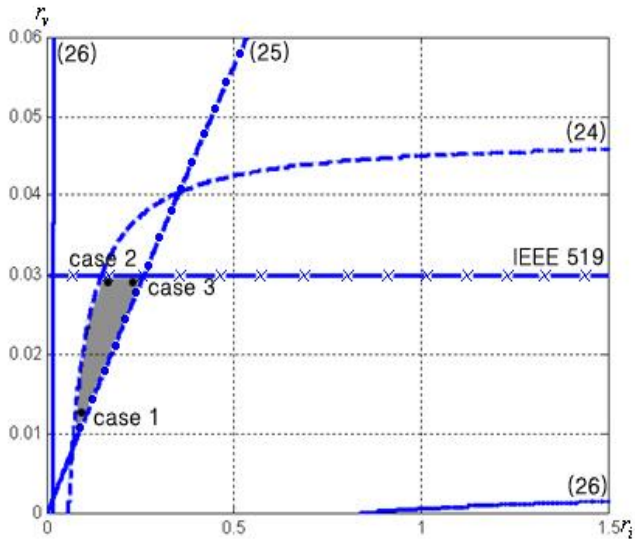

Fig. 6. Region of r_i and r_v meeting filter design criterion.

with the slight change of the inductance ratio. In case 2, the output current THD_i is lower than that in case 1 even with the smaller inductance and the change of the filter effect is steady with the change of the inductance ratio. In case 3, it shows a good filter effect with the small total inductance value. But the size of the inverter side inductor is small, so the filter effect for the low voltage harmonics at the stand-alone mode may be a little bad. It is represented in Fig. 3 that the filter effect is best near the inductor ratio of 0.7 to 1.2. And it shows that the filter effect is significantly unchanged when the inductance ratio is between 0.6 and 1.5, even though the inductance is changed by external factors.

How much value of the current ripple can be reduced by the grid side inductor is described by the factor of output current attenuation ratio, σ , defined as the ratio of grid current harmonics to inverter current harmonics as (28).

$$\sigma = \frac{i_{g,sw}}{i_{i,sw}} = \frac{1}{\omega_{sw}^2 L_g C_f + 1} \quad (28)$$

The change of the output current ripple attenuation ratio according the inductance ratio can be represented by substituting (27) into (28) as in Fig. 8. Figure 8 shows that the output current attenuation ratio is reduced significantly when the inductance ratio changes from 0.1 to 0.6 as shown in case 1 and it may be almost steady when the inductance ratio is bigger than 1.5 as shown in case 2 and case 3.

The magnitude of current ripple included in the current of inverter side inductor is different depending on the size of inverter side inductor. Table 4 shows the maximum current ripple flowing through the inverter side inductor. Considering the current ripple flowing through the inverter side inductor, the voltage drop at the inductor and the burden of current to the elements of inverter can be reduced. And so, the efficiency of the system can be increased [14]. Thus, though the parameter values of LCL filter are selected to meet the design criteria, they may not be optimal in application system. Empirically the inductance ratio is to be 0.7 to make the inductor current small and to keep the change of the filter effect and the output current ripple attenuation to be small in

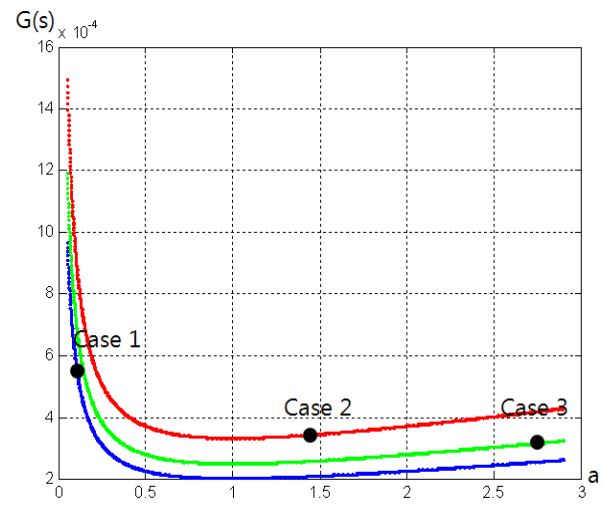

Fig. 7. Relation between filtering effect and inductor ratio.

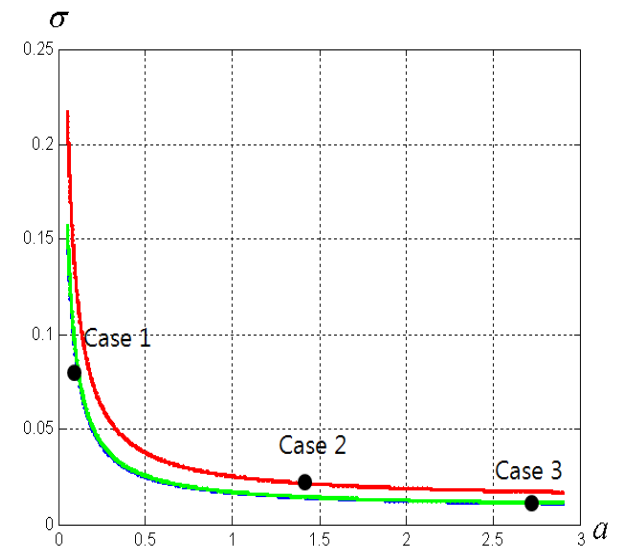

Fig. 8. Relation between output current attenuation, σ and inductor ratio, a .

spite of the change of inductance value.

Table 4. Ripple current of inverter side inductor

Maximum ripple current	Case 1	Case 2	Case 3
$i_{rp,max}$	1.2A	2.3A	4A

Substituting the designed values of L_i and L_g as shown (18) and (24) into (27), the ripple current ratio r_i is given as (31).

$$r_i = \frac{r_g(Aa + 6\sqrt{3}r_v V_g)}{6\sqrt{3}r_v V_g} \quad (29)$$

From (29), the relations between r_i and r_v are described as in Fig. 9 at the given values of a . The filter parameter values at the maximum and minimum values of r_i at $a=0.7$ in Fig. 9 are shown in Table 5.

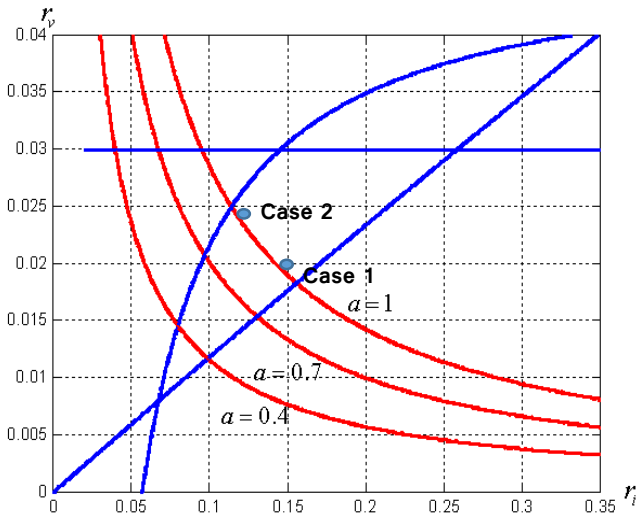

Fig. 9. Relation between r_i and r_v at different values of a .

Table 5. Maximum ripple current $i_{rp,max}$ and LCL filter parameters according to r_i

Parameters	Case 1	Case 2
r_i	0.1312	0.09736
r_v	0.01526	0.02067
L_i [mH]	1.1	1.5
C_f [μ F]	14	7.5
L_g [μ H]	780	1,100
f_{res} [Hz]	1,992.4	2,323.7
$i_{rp,max}$ [A]	1.9	1.3

When r_i is minimum, the total inductance is bigger and the filter capacitance is smaller than those of r_i maximum condition. Simulation results show that the THD of the output current in both cases is less than 3%. The critical load voltage THD of case 1 is lower than that of case 2. The maximum ripple current of each case is 1.9A and 1.3A, respectively. In small rated system, the difference of this ripple current may not a big deal, but high rated system, the inverter current ripple is more serious. Therefore as the increase of the rated power, the inverter current ripple should be considered with more weight. Between two cases, the case 1 of which r_v is smaller, the resonance frequency of the LC filter is further far from the switching frequency. Therefore, if it works under both grid-connected mode and stand-alone mode, the LCL filter in case 1 is suitable for an optimal value of the system.

3. Simulation

Figure 10 shows the current waveform of inverter side inductor, and Fig. 11 shows the harmonic spectrum of this current with 5.1% THD_i. It shows the dominant harmonic component at the switching frequency of 10kHz. Figure 12 shows the current waveform of grid side inductor and its THD_i is 1.6%, which satisfies the regulation of grid connection.

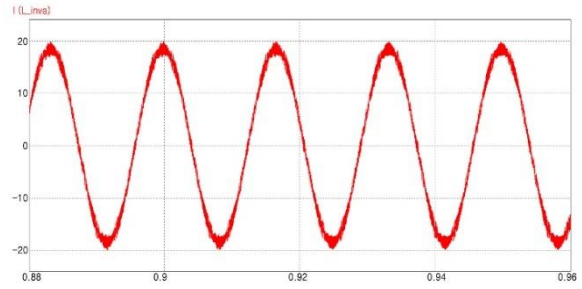

Fig. 10. Simulation results of inverter output current.

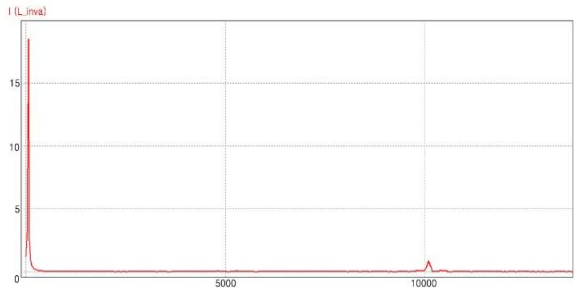

Fig. 11. Simulation results of harmonic spectrum for inverter output current.

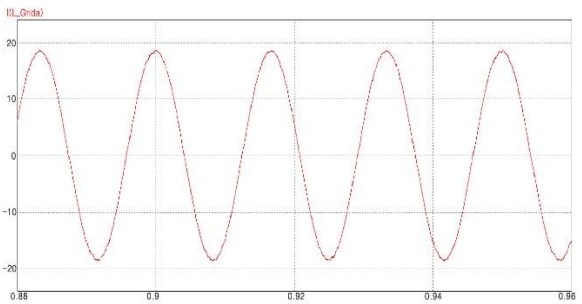

Fig. 12. Simulation results of grid current.

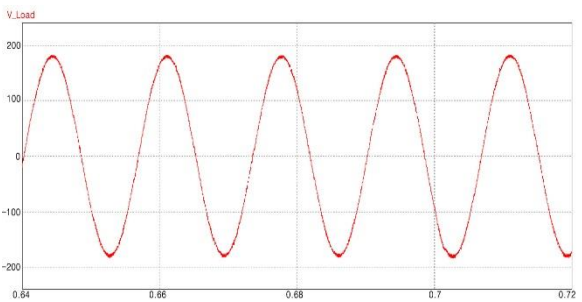

Fig. 93. Simulation results of capacitor voltage under grid-connected mode.

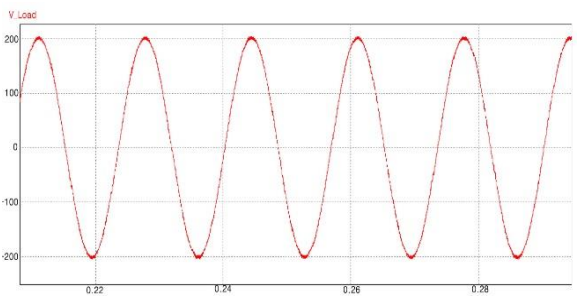

Fig. 104. Simulation results of capacitor voltage under stand-alone mode.

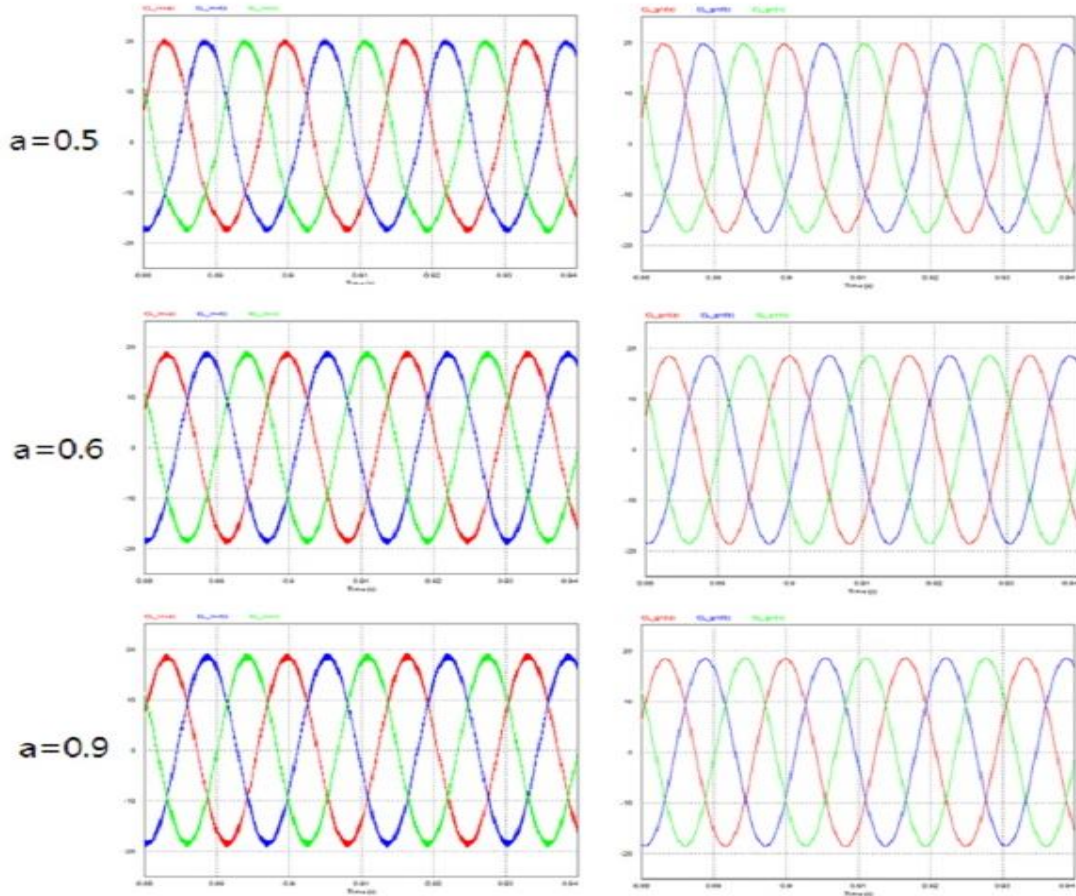

Fig. 15. Simulations results of inverter output current (left) and grid current (right) at different value of a .

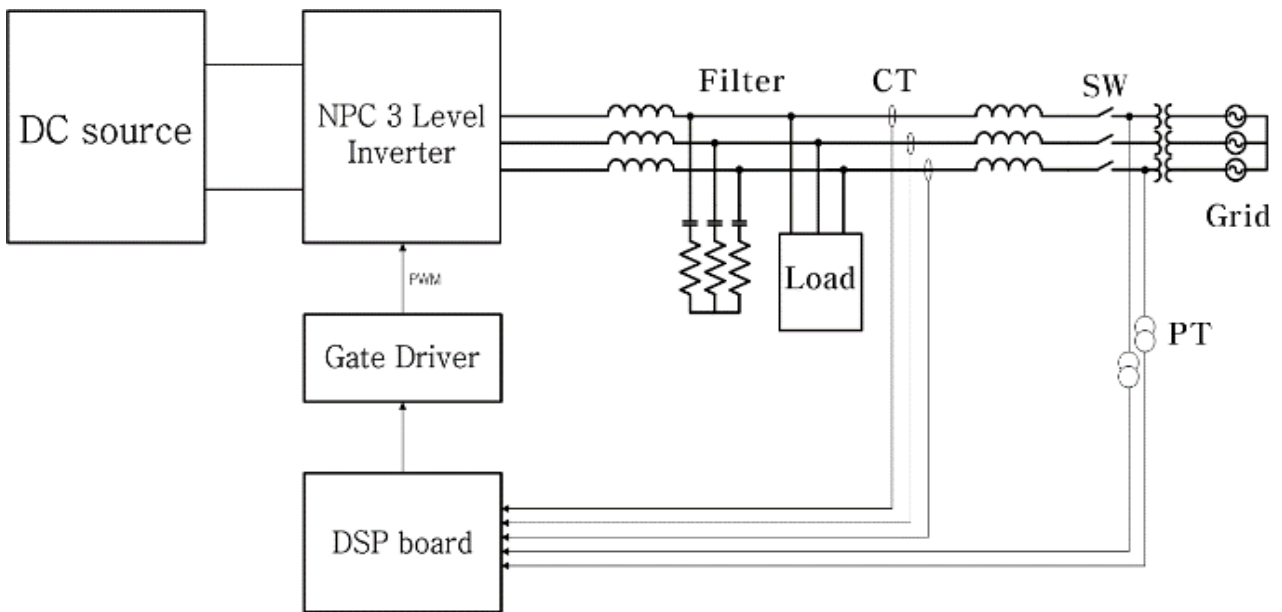

Fig. 116. Configuration of power circuit for experiments.

Figure 13 shows the waveform of the capacitor voltage under the grid-connected mode with 1.2% THD_v.

Figure 14 shows the waveform of capacitor voltage under the stand-alone mode with 1.1% THD_v. Both values are below 0.3 and well meet the regulation of grid connection.

Figure 15 shows the waveforms of inverter output current (left) and grid current (right) at different values of inductor ratio, a of 0.5, 0.6, and 0.9, respectively. Their THD_i are 2.5%, 1.6%, and 1.7%, respectively.

4. Experiment

Figure 16 shows the configuration of experimental system. DC renewable energy source is connected to the grid through NPC 3-level inverter. And the local critical load is connected to the output of capacitor to be supplied from the DC source even though the disconnected condition with grid due to any line faults. By measuring the line voltage of the grid, PLL (Phase-locked loop) is performed to synchronize the phase of inverter output voltage to that of grid voltage.

Figure 17 shows the result of PLL. The green line shows the phase value of grid voltage by using PLL and the red line shows the output voltage waveform. Figure 18 shows the voltage and current waveforms of phase a. Two waveforms are in phase and the current THD_i is 2.4%. Compared with the simulation result, the experiment result shows a little bit higher THD_i but it meets the criterion well. Figure 19 shows the waveform of capacitor voltage for local loads under the stand-alone mode with the voltage THD_v of 2.1%.

5. Conclusion

In this paper, the design method of LCL type filter for grid-connected NPC 3-level inverter is proposed. By analyzing the ripple current according to the switching of NPC three-level inverter, the inverter side inductor is designed without any information about the modulation index. Three design criteria are applied to meet the given specifications of inductor voltage drop, current ripple rate, and reactive power absorbed by filter capacitor. And the design area to meet the design criteria of LCL filter has been shown. In addition, by considering the relation between the filtering effect and the attenuation of output current and the inductance ratio of grid side inductor to inverter side inductor, the optimized value of LCL filter has been designed. Through the simulation and experimental results, it has been verified that the designed values are well meet the design criteria.

Acknowledgement

This work was supported by the research grant of Chungbuk National University in 2013

References

[1] T. Ackermann, G. Andersson, and L. Soder, "Electricity Market Regulations and Their Impact on Distributed Generation," in *Conf. Rec. of Electric Utility Deregulation and Restructuring and Power Technologies*, pp. 608-613, 2000.

[2] M. Lisserre, F. Blaabjerg, and Steffan Hansen, "Design and Control of an LCL Filter Based Three Phase Active Rectifier," *IEEE Trans. Ind. Appl.*, vol. 41, no. 5, pp. 1281-1291, 2005.

[3] Malikarjuna G D, Naik R L, and Suresh H. Jangamshetti, "Performance Analysis of Three Level Inverter for L & LCL Filters Connected to Grid," *Int. Journal of Scientific & Engineering Research*, vol. 3, no. 6, pp. 1-7, 2012.

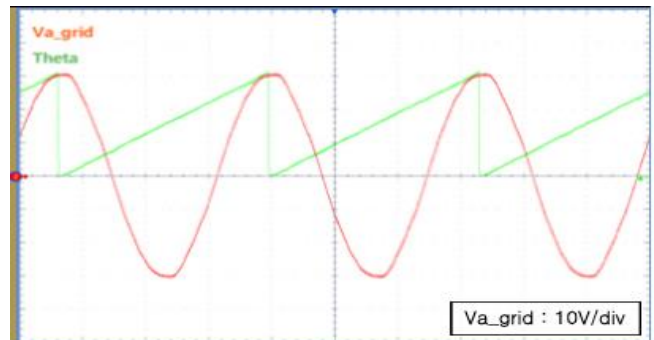

Fig. 17. Results of PLL.

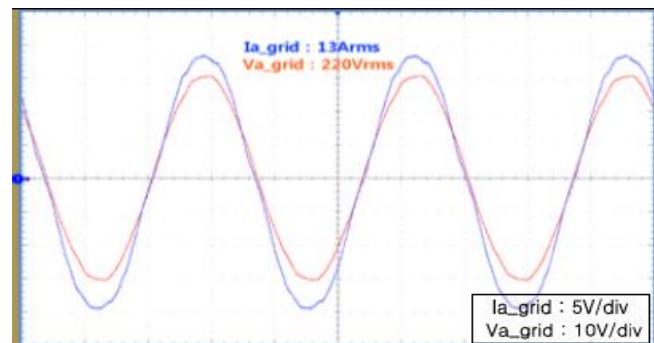

Fig. 18. Voltage and current waveforms of phase a.

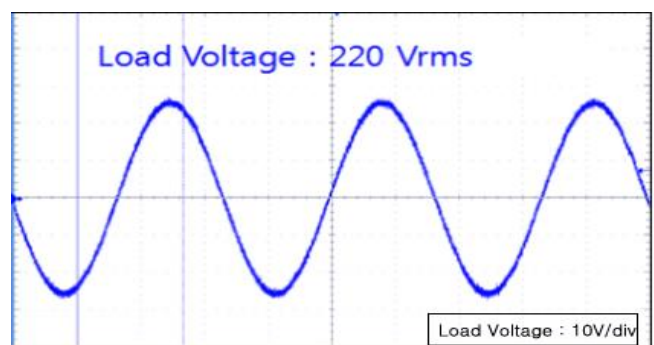

Fig. 19. Load voltage waveform under stand-alone mode.

[4] Youcef Soufi, Sihem Ghodelbourk, Tahar Bahi, and Hichem Merabe, "Harmonics Minimization of Multilevel Inverter Connecting Source Renewable Energy," *International Journal of Renewable Energy Reserch*, vol. 1, no. 4, pp. 265-270, 2011.

[5] Frede Blaabjerg and Eftichios Koutroulis, "Methods for the Optimal Design of Grid - Connected PV Inverters," *International Journal of Renewable Energy Reserch*, vol. 1, no. 2 pp. 54-64, 2011.

[6] Yongqiang Lang, Dianguo Xu, Hadianamrei S.R., and Hongfei Ma, "A Novel Design Method of LCL Type Utility Interface for Three-Phase Voltage Source Rectifier," in *Conf. Rec. of IEEE PESC'05*, pp. 313-317, 2005.

[7] Min-Young Park, Min-Hun Chi, Jong-Hyoung Park, Heung-Geun Kim, Tae-Won Chun, and Eui-Cheol Nho, "LCL-filter Design for Grid-Connected PCS Using Total Harmonic Distortion and Ripple Attenuation Factor," in *Conf. Rec. of IPEC'2010*, pp. 1688-1694, 2010.

- [8] Hamid R. Karshenas and Hadi Saghafi, "Basic Criteria in Designing LCL filter for Grid Connected Converters," in *Conf. Rec. of IEEE ISIE'2006*, vol. 3, pp. 1996-2000, 2006.
- [9] Sang-Hyuk Jung and Se-Wan Choi, "Optimized LCL filter Design Method of Utility Interactive Inverter," *Trans. of KIPE*, vol. 18, no. 1, pp. 103-109, 2013.
- [10] A. Nabae, I. Takahashi, and H. Akagi, "A New Neutral Point Clamped PWM Inverter," *IEEE Trans. Ind. Appl.*, vol. 17, no. 5, pp. 518-523, 1981.
- [11] S. Vasconcelos Araujo, A. Engler, and F. L. M. Antunes, "LCL Filter Design for Grid-Connected NPC Inverters in Offshore Wind Turbines," in *Conf. Rec. Of ICPE'2007*, pp. 1133-1138. 2007.
- [12] Biying Ren, Xiangdong Sun, Shaoliang An, Xiangui Cao, and Qi Zhang, "Analysis and Design of an LCL Filter for the Three-level Grid connected Inverter," in *Conf. Rec. of IPEMC'2012*, vol. 3, pp. 2023-2027, 2012.
- [13] N. Yu, J. Yang, S. Chen, and M. Ye, "Design of LCL-Filter Based Three-Level Active Power Filters," *TELKOMNIKA Indonesian Journal of Electrical Engineering*, vol. 12, no. 1, pp. 48-56, 2014.
- [14] *Recommended Practices and Requirement for Harmonic Control in Electrical Power Systems*, IEEE Std. 519, 1992.
- [15] *Standard for Interconnecting Distributed Resources With Electric Power System*, IEEE Std. 1547.2, 2008.
- [16] Fang Liu, Xing Zhang, Changzhou Yu, and Zhangping Shao, "LCL Filter Design for Grid connected Three Phase PWM Converter Based on Maximum Current," in *Conf. Rec. of IPEMC'2013*, pp. 631-635, 2013.