

Original Review Article

Vehicle Retarder Systems

Ibrahim Dogan^{1,*}, Hasan Aydoğan².

¹*Selcuk University, Institute of Science, Mechanical Engineering, Campus, Selcuklu, Konya, Turkey*

²*Selcuk University, Technology Faculty, Campus, Selcuklu, Konya TURKEY*



ARTICLE INFO

* Corresponding author
ibrahimdogan0594@gmail.com
Received 27 January 2021
Received in revised form
18 March 2021
Accepted 18 March 2021

Published by Editorial Board
Members of RESEPTEM

© This article is distributed by
Turk Journal Park System under
the CC 4.0 terms and conditions.

ABSTRACT

Security systems are the most important feature required for motor vehicles. The most important of these systems are brake systems. Due to the inadequacy and costly maintenance of conventional brake systems, auxiliary brake systems have been developed. In this review, theoretical information about vehicle deceleration systems and regenerative braking systems, especially used in heavy vehicles, is clearly stated.

Keywords: brake system, retarder, regenerative brake

Introduction

The most important feature sought in motor vehicles is the security system. The systems that enable the motion to be controlled or stopped by converting the motion energy into heat with friction are called brake systems. Pressure forces are used in brake systems [1]. Disc brake systems are generally used in vehicles [2].

Hydraulic brake systems, disc brake systems, drum brake systems and air brake systems are used in vehicles. The difference between these systems is that different methods are used to transmit the brake force to the wheels and brake pads. Pascal law has been used in the hydraulic brake system. In disc brakes, the brake disc compressed between the pads provides braking. Drum and shoe pads are used in drum brakes. Shoe pads provide braking by rubbing on the inner surface of the drum. Air brake systems, on the other hand, provide maximum braking with less brake force in larger and heavier vehicles.

However, air brake systems have more components than other systems.

In conventional brakes, the kinetic energy of a moving vehicle is converted into heat through the friction mechanism between the brake disc and brake pads [3]. In conventional brakes, problems such as thermo-mechanical failure [4-6], brake fading problems [7,8], rake jitter problems [9], disc distortions and brake squeak [10-13] can occur.

Mechanical friction, corrosion and erosion cause wear and make mechanism elements unusable in brakes [14]. Disc surfaces are eroded with use. Physical and chemical changes in discs can occur with this wear [15].

Due to frequent failures in brake systems and damage to components, disadvantages have emerged both in terms of time and cost. In addition, sudden failures in the brake systems both damage the vehicle and increase the

possibility of an accident. In order to protect these systems, vehicles and people, auxiliary braking systems have been developed. These; anti-lock braking system (ABS), traction control system (ASR / TRC / TC / TCS), electronic stability system (ESP / VSC / VDC / ESC) and electronic brake force distribution system (EBD / EBV).

In addition to these systems in heavy vehicles, various vehicle deceleration systems have been developed to reduce the load on the main brake system. These systems are intended to use less brakes by keeping the vehicle under control. Thus, possible brake failures, accident probability and costs are minimized.

Many people have made long journeys by bus. In these journeys, a buzzing sound that sounds especially good on night trips has taken place in the memories. For those who do not know this sound, although it is considered as the sound of larger engines and gearboxes in vehicles such as buses and trucks, it is actually a sound originating from retarder systems.

1. Retarder

Retarder, which has meaning such as decelerator as the meaning of the word, is defined as 'speed breaker' in engineering applications. Retarder is an auxiliary braking system that allows the vehicle to brake without applying conventional brakes [16]. By definition [17], a retarder is a continuous brake where the retarding torque is not generated by the friction between two sliding surfaces, such as pads and a drum. Therefore, they are essentially wear-free brakes.

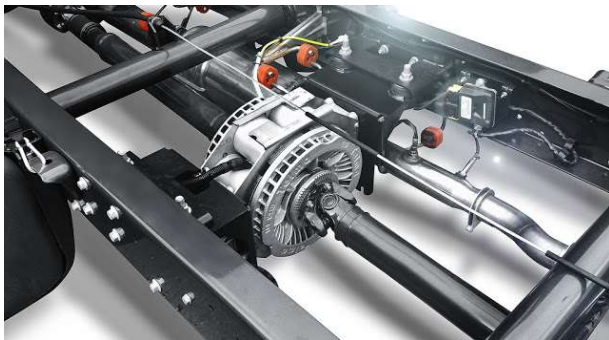

Figure 1.1. Retarder

It was first produced by Voith company in the 1950s to stop freight trains of kilometers long in the USA. Later, Otto Kassbohrer was assigned to Voith company to apply it on buses. Thus, heavy vehicles met the retarder [18].

Retarder is a secondary brake mechanism that is mostly preferred in vehicles such as trucks and buses. The main purpose of the retarder system is not to stop the vehicle, but to slow it down and prevent excessive load on the

main brake system. Both brake systems are independent



Figure 1.2. Freight train

of each other and can be used separately [18]. In other words, it is not necessary to use the main brake system to use the retarder system.

Looking at the advantages of Retarder systems [18];

- Significantly extends the life of primary brakes.
- Soft and smooth deceleration and braking are possible without impairing the comfort level.
- Downhill braking also provides a great advantage and extra safety.
- Downhill acceleration can be controlled without the need for primary brakes.
- Because brake pads wear much less, harmful pad dust pollutes the environment much less.
- It operates independently from the gearbox because it is driven from the cardan shaft, that is, the shaft, there is no interruption in the brake power during gear shifting.
- Since the use of the vehicle linings decreases, the wheels do not get hot, thus the life of the linings, drums and tires is extended.

The changing parts of the vehicle using and not using the retarder are compared in Table 1.1. The most difference appears on the pads. In a vehicle that does not use a retarder, there is a change of 10 times the pads at the same distance compared to the vehicle using it. The service period required for the replacement of wheels, drums and pads at the same distances is 9 days for a retarded vehicle and 58 days for a vehicle that does not use a retarder.

The general scheme of the retarder system placement in the vehicle is given in Figure 1.3. The display screen shown with number 1 is used to display the situations in which the retarder is enabled or disabled. Retarder key is specified with number 2. Used to gradually engage the retarder. It can also work together with the speed stabilizer operation indicated by the retarder number 3. Retarder ECU is specified with number 4 and retarder with number 5.

Table 1.1. Comparison of parts replacement of vehicles with and without retarder [19]

Changed Parts	Retarder Available		No Retarder	
	Part Replacement km	600 thousand km how many times have been changed	Part Replacement km	600 thousand km how many times have been changed
Wheel	200.000	3	150.000	4
Pad front	300.000	2	30.000	20
Pad back	200.000	3	20.000	30
Drum	600.000	1	150.000	4
Out of service		9 day		58 day

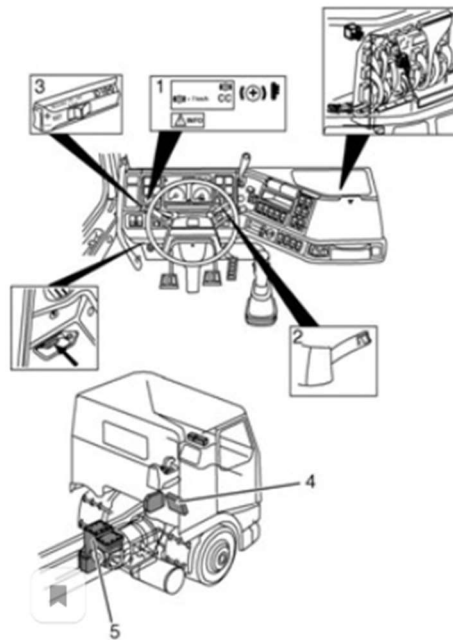

Figure 1.3. General layout scheme of the retarder system

Retarder switch has different stages (Figure 1.4.). Inactive in position 0. When used in position A, when the brake pedal is lightly pressed, the retarder is activated and applies the necessary braking force with the help of sensors. Manual braking is used in 1-2-3 positions. The braking force increases as it is pulled down in these stages, which are completely under the control of the driver. Position B is only available for vehicles with automatic transmission. Applies the maximum braking force [20].

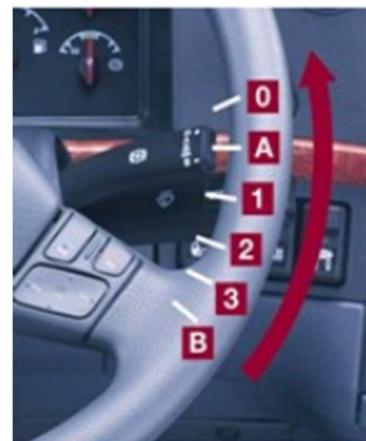

Figure 1.4. Retarder switch stages

2. Primary Retarder Systems

Engine brake and exhaust brake are primary retarder systems. These systems directly affect the cylinders of the vehicle. Unlike other retarders, these systems can take place in a heavy vehicle at the same time.

2.1. Engine Brake

Although many people call the deceleration they achieve at the current speed of the vehicle as engine brake, the engine brake used in heavy vehicles, also known as Jake brake, is a retarder system and does not require downshifting [21].



Figure 2.1. Engine brake

It is activated by a button at the request of the driver and applied in different stages according to the need. However, its purpose is not to stop the vehicle like all retarder systems, but to slow it down [21].

The engine brake has a hydro-mechanical operating principle and is described as a kind of valve mechanism system that can be activated at any time.

The working phases of a four-stroke typical diesel

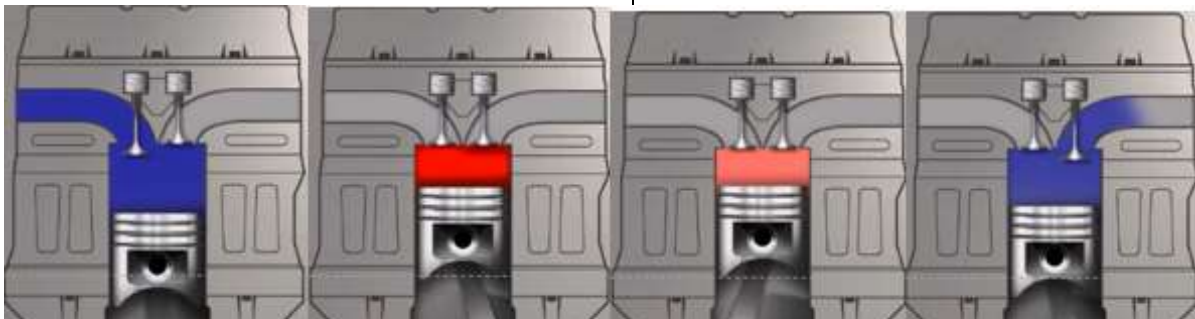

Figure 2.2. Diesel engine operating phas

engine are given in figure 2.2. While the piston moves down, the intake valve is open, the exhaust valve is closed, and fresh air is sucked into the cylinders. While the piston will move up, both valves are closed and the sucked fresh air is compressed. Injectors then spray the

fuel and the compressed air is ignited by the spray pressure and the piston is pushed down as a result of the explosion resulting from the fuel burning. Thus, work is done. The opened exhaust valve also discharges the gases generated by the burning mixture out of the exhaust valve in the exhaust phase. The working principle of the diesel engine is directly related to the working principle of the engine brake.

This system has an electrically controlled solenoid valve. When activated by means of a button located in the cockpit or on the steering wheel, engine oil passes through special channels in the system and activates the mechanism in the exhaust valve. As a result, the exhaust valve should be closed during the compression phase, but remains open for most of this phase (Figure 2.3.) [21].

Considering that the fuel injection is also interrupted, the air entering the cylinders is thrown directly from the exhaust valve in a controlled manner. Considering that the gearbox is still connected to the engine and moves on its pistons, the controlled compression that occurs in the cylinders creates a kind of vacuum effect and causes the engine to brake. As a result, the engine starts to slow down the vehicle. During these processes, a very loud noise is generated [22].

2.2. Exhaust Brake

It is included in both heavy vehicles and some small and medium sized light commercial vehicles. It is simpler and cheaper than a motor brake, but has a lower deceleration effect [23]. Typically made of ductile iron, exhaust brakes block the exhaust path, creating negative torque in the engine and slowing down vehicles [24].

The flow of exhaust gases discharged from the cylinders is throttled by a collapsible flap mechanism located at the

manifold outlet and compression within the cylinders is ensured. In the opposite direction of movement on the pistons, a pressure is created by the exhaust gases.

Thanks to this pressure, the movement of the pistons and crankshaft is restricted. So the vehicle slows down [21].

2.2.1. Exhaust brake valve

Exhaust brake valves are used to activate the exhaust

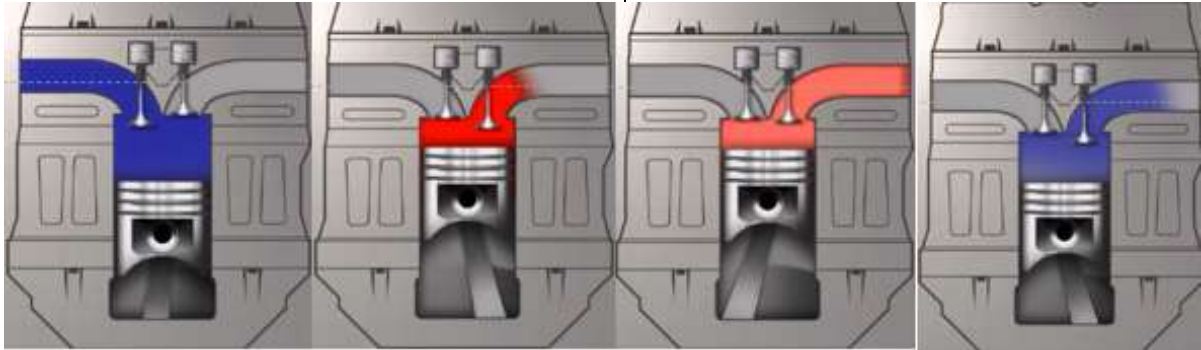

Figure 2.3. Diesel engine operating phas



Figure 2.4. Exhaust brake

The exhaust brake usually engages when the vehicle is off the accelerator and the fuel flow in the engine must be shut. If the fuel flow is not cut;

- Increase in fuel consumption
- Turbo bearing and fins are not damaged
- Engine overpressure

why.

The flap mechanism is never fully closed, a certain amount of exhaust gas flows. If it closes completely; causes excessive pressure build-up in the engine and exhaust system.

brake in desired situations and without damaging engine parts. There are many different types of exhaust brakes, but generally the working principles are the same. The exhaust brake valve used in MAN brand vehicles is shown in Figure 2.7.

Exhaust brake valve is a mechanism that can control the flap in the exhaust pipe thanks to the proportional valve inside.

Exhaust brake valve is powered by air. It sends the air it takes from the inlet line to the piston of the valve in a controlled and gradual manner, thanks to the proportional valve inside. As a result of the forward movement of the piston, the valve closes and the exhaust

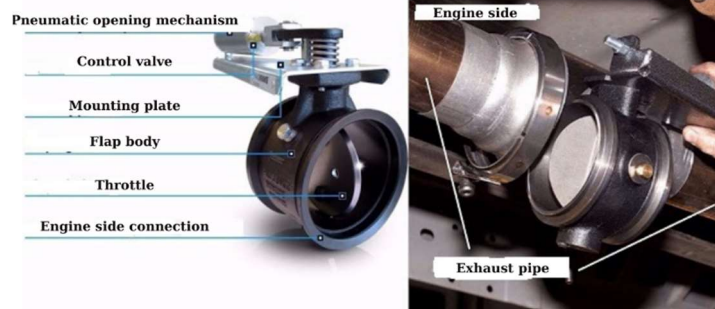

Figure 2.5. Exhaust brake elements

brake is activated. Proportional valve does not direct all incoming air to the outlet line. While the valve, which is activated by the proportional valve, transmits a certain air to the outlet line, the remaining amount of air is sent to the discharge line. When the exhaust brake is disabled or the vehicle is stopped, the remaining air in the system is discharged from the discharge line.



Figure 2.6. Damage caused by exhaust brake malfunctions

There is a pressure sensor line in order for the exhaust brake valve to read the pressure in the exhaust pipe. Pressure is sent to ECU with the help of the sensor inside the valve. It provides a controlled deceleration by activating the proportional valve with the load status, speed and pressure information of the vehicle in the ECU with the help of the connection cable and the socket in it.



Figure 2.7. Exhaust brake valve used in MAN vehicles

In case of failure, there is a sealed cover on the valve that will release when a certain pressure amount is exceeded in order to prevent a sudden pressure increase in the valve and consequently the engine from being damaged. There is a filter cap on the body for atmospheric pressure.

The most important element of the exhaust brake valve is the proportional valve (figure 2.9). It is the part that controls the air passage by being under the influence of the magnetic field with the ECU's signal. The parts

inside move back and forth with the effect of magnetic field. When it is active, the spring inside retracts and directs the air passage from the discharge to the outlet line. When the signal is interrupted, thanks to the non-magnetic parts, the moving parts lose the effect of the magnetic field and succumb to the force of the spring, thus cutting the air going to the exit line. Proportional



valve alone does not provide air flow control. Thanks to the valve at its outlet, the air is directed in a controlled manner (Figure 2.10).

When the exhaust brake valve provides the maximum pressure, the exhaust valve closes at the maximum angle and braking is provided. The situation in which the valve is closed and the situation where it provides the maximum pressure are shown in Figure 2.11.

Looking at the exhaust brake valve test table (table 2.1), there is an inlet pressure of 6 bar. When the PVM signal is 29%, the output pressure starts to increase and the voltage at this moment is 6.7 voltages. The PVM signal has reached its maximum pressure after reaching 55%. However, the volt value continues to increase with the PVM signal.

Looking at the pressure change graph (Figure 2.12), it is seen that the output pressure increases proportionally when the PVM signal is between 25% and 55% and the valve provides active duty only in this range.

When looking at the voltage change graph (Figure 2.13), it is seen that it increases with the PVM signal.

Looking at the output data (Figure 2.14), it is seen that the valve is active between 6-12 voltages.



Figure 2.8. Exhaust brake valve design

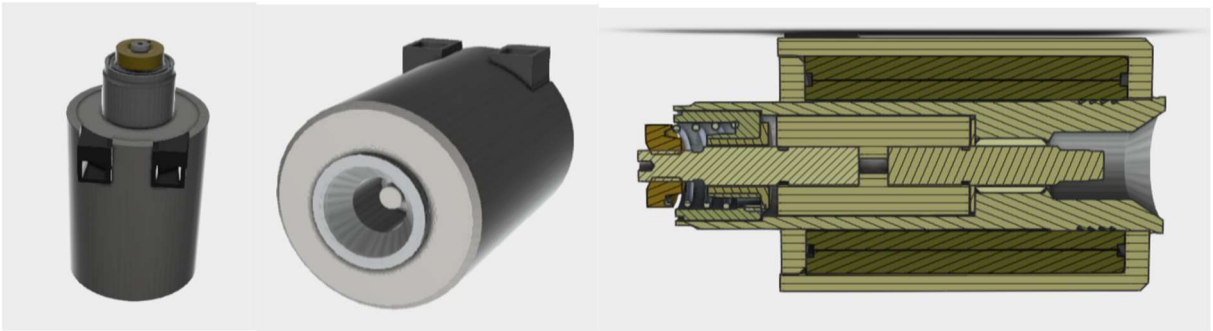

Figure 2.9. Proportional valve

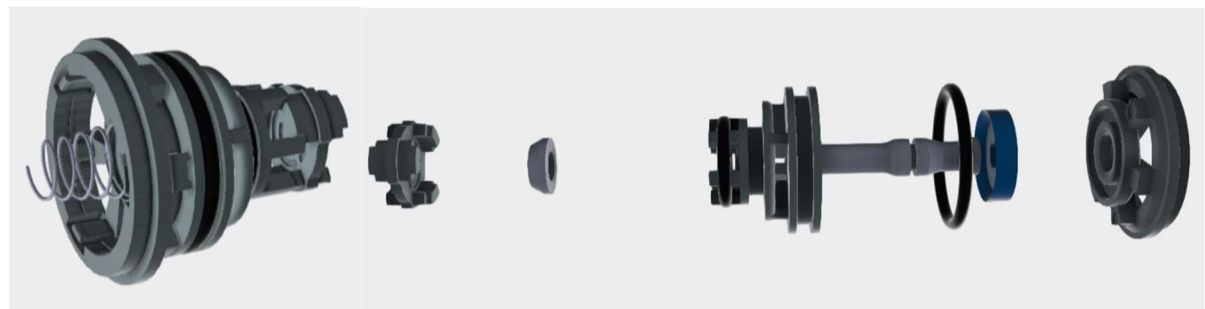

Figure 2.10. Pressure relief valve

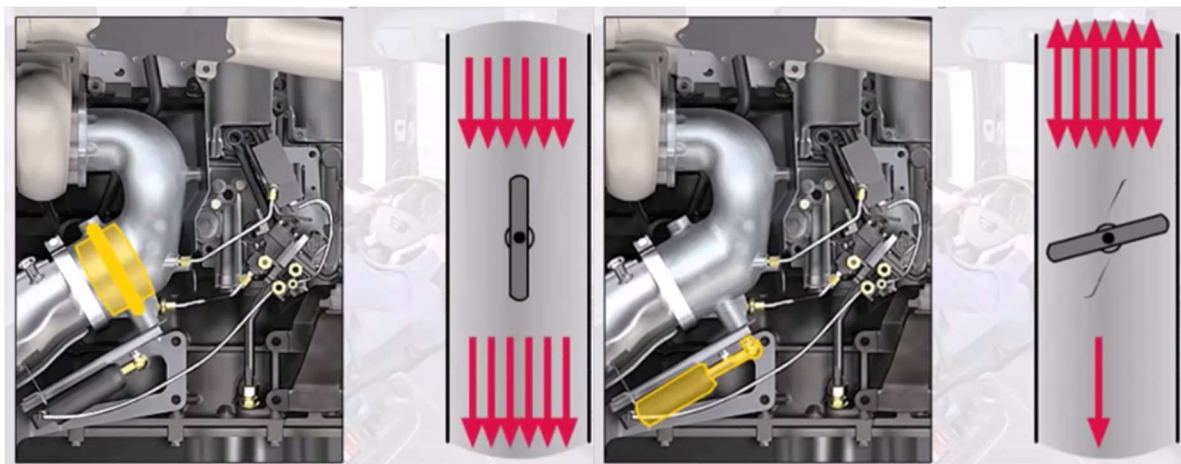

Figure 2.11. Throttle movement in passive and active states of the exhaust brake valve

Table 2.1. Exhaust brake valve test values

Inlet Pressure (Bar)	PWM Signal (%)	Outlet Pressure (Bar)	Voltage
6 Bar	5	0	1
6 Bar	10	0	2,2
6 Bar	15	0	3,4
6 Bar	20	0	4,6
6 Bar	25	0	5,8
6 Bar	26	0	6
6 Bar	27	0	6,2
6 Bar	28	0	6,5
6 Bar	29	0,17	6,7
6 Bar	30	0,36	7
6 Bar	31	0,55	7,2
6 Bar	32	0,78	7,5
6 Bar	33	1,03	7,7
6 Bar	34	1,27	7,9
6 Bar	35	1,52	8,2
6 Bar	36	1,78	8,4
6 Bar	37	2,04	8,7
6 Bar	38	2,29	8,9
6 Bar	39	2,54	9,1
6 Bar	40	2,81	9,4
6 Bar	41	3,07	9,6
6 Bar	42	3,33	9,9
6 Bar	43	3,58	10,1
6 Bar	44	3,84	10,3
6 Bar	45	4,09	10,6
6 Bar	46	4,32	10,8
6 Bar	47	4,56	11,1
6 Bar	48	4,79	11,3
6 Bar	49	5,03	11,6
6 Bar	50	5,25	11,8
6 Bar	51	5,44	12
6 Bar	52	5,68	12,3
6 Bar	53	5,89	12,5
6 Bar	54	5,92	12,8
6 Bar	55	6	13
6 Bar	60	6	14,2
6 Bar	65	6	15,4
6 Bar	70	6	16,6
6 Bar	75	6	17,8
6 Bar	80	6	19
6 Bar	85	6	20,2
6 Bar	90	6	21,5
6 Bar	95	6	22,7
6 Bar	100	6	23,5

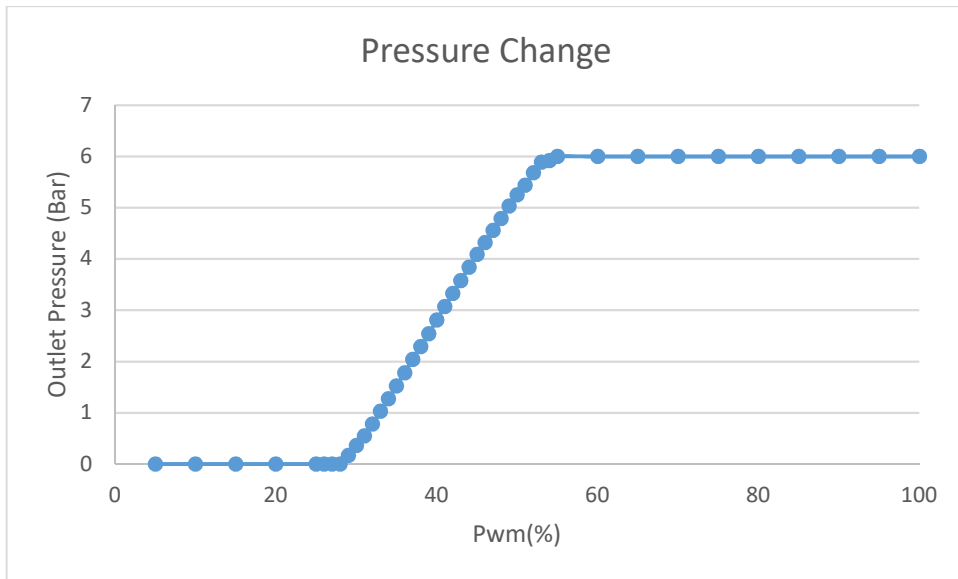

Figure 2.12. Exhaust brake valve pressure change

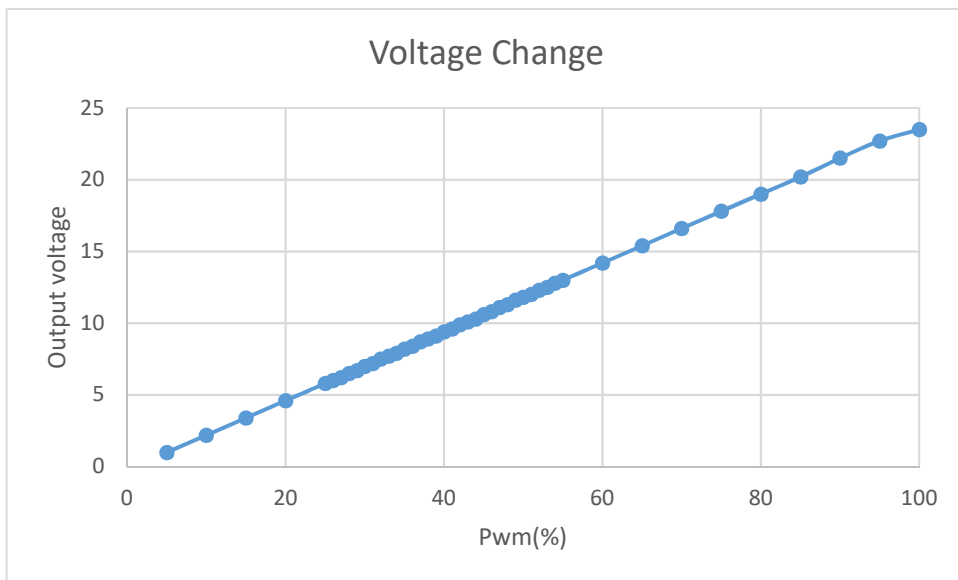

Figure 2.13. Exhaust brake valve voltage variation

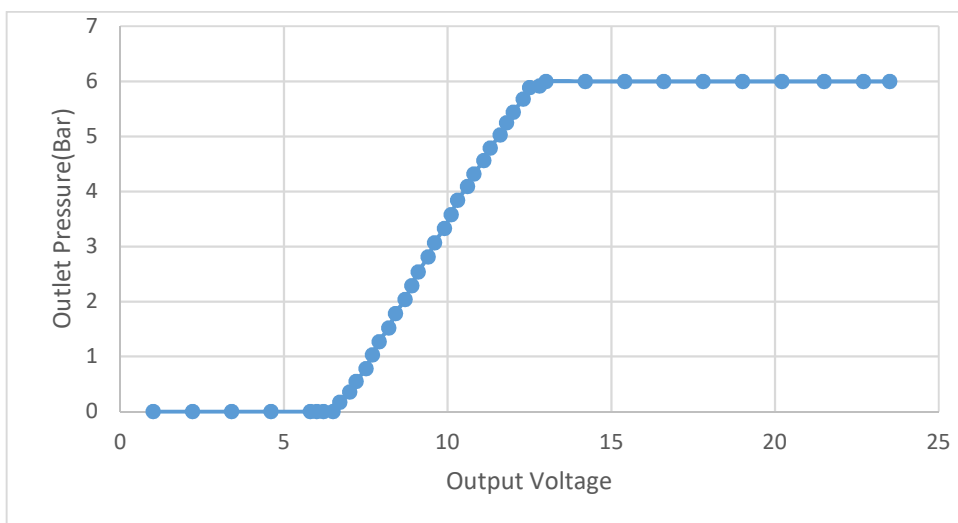

Figure 2.14. Comparison of exhaust brake valve output data

3. Secondary Retarder Systems

Hydrodynamic and electromagnetic retarders are secondary retarder systems. These systems do not directly affect the engine of the vehicle like primary retarder systems. They slow down the vehicle by acting on the propeller shaft. Secondary retarder systems don't happen in a vehicle at the same time. These systems are alternatives to each other and have advantages over each other.

3.1. Hydrodynamic Retarder

It is basically a hydrodynamic pressurized system powered by two impellers called rotors and stators placed at the end of the shaft. Hydrodynamic retarder, an important auxiliary braking system in heavy vehicles, mainly depends on the flexible preventing effect on the transmission to create a braking effect [25].

Based on liquid damping effect, hydrodynamic retarder is widely used in heavy vehicles with advantages such as soft braking, high speed braking and low noise level [26].

While the gears rotate, the rotor continues to rotate. When oil is filled into the rotor, it closes with a stator. As a result of this closure, while the stator remains stable, the rotor continues to rotate (Figure 3.3.) [27, 18].

Oil is mobilized by the movement transmitted by the engine. Rotational movement of oil hits the stator. Since both of them have an angled blade structure, the rotational movement of the oil slows down the system. Since the rotor slows down, the gears connected to it also slow down. Thus, the movement from the gearbox is braked and the vehicle slows down (Figure 3.4.) [27, 18].

When the system goes out of control and starts going at normal speed, the combined Mechanism opens and returns to the oil liquid reservoir. The returning oil temperature increases. Because of the motion energy, it is transformed into heat energy as there must be a transformation in energy. Since the oil needs to be cooled, the heat exchanger system comes into play here. The coolant passing through the channels with the help of the radiator reduces the temperature of the oil and returns to the radiator as it is heated. Since oil and

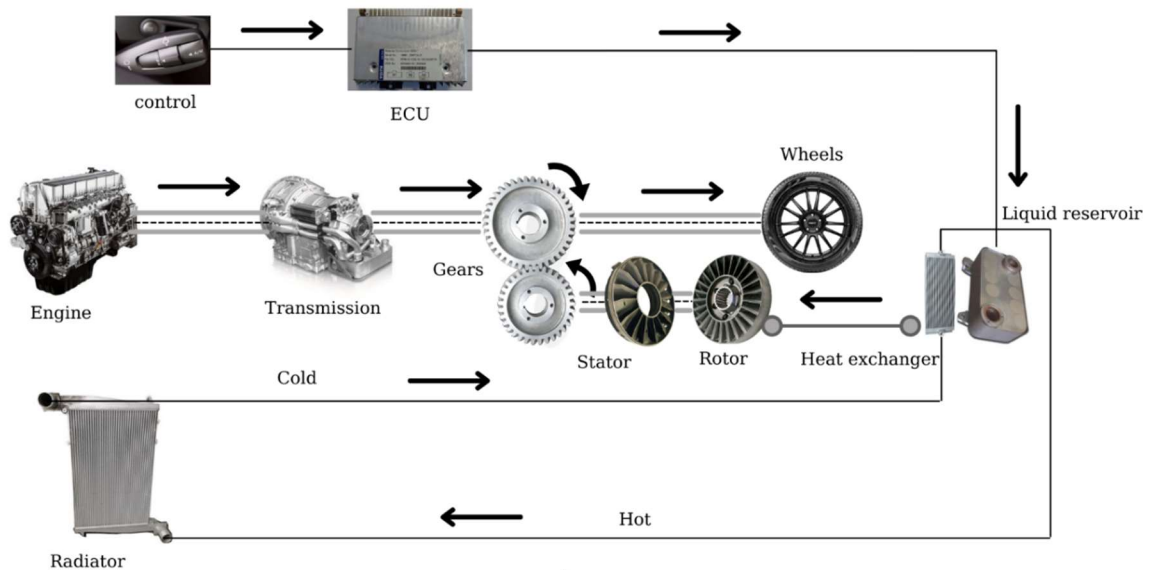

Figure 3.1. Schematic representation of the operation of the hydrodynamic retarder [18]

The motor transfers the rotational movement to the gearbox and then the resulting rotational movement is transmitted to the wheels. However, a vehicle with a hydrodynamic retarder system has a large gear behind the gearbox. Connected to 1 to 2 small gear to ensure power transmission. The small gear is on the same shaft as the stator and rotor (Figure 3.1.) [18].

When the driver gives a command from the control system, a signal comes from the ECU and the system is started. High pressure air presses the oil in the liquid chamber and thanks to this pressure, the oil begins to fill into the rotor (Figure 3.2.) [27, 18].

coolant pass through each other with the help of channels, there is no contact (Figure 3.5) [27, 18].

3.2. Electromagnetic Retarder

The magnetic flux theory, which was discovered by the French physicist Leon Foucault in the middle of the 19th century and named after him, became the basic basis of the working principle of the electromagnetic retarder. In 1903, the inventor named Steckel patented the eddy current converter, the theory of electromagnetic retarder. In 1936, the explorer Raoul Sarazin first used a practical system based on magnetic flux theory as an additional



Figure 3.2. Pressing the oil into the system

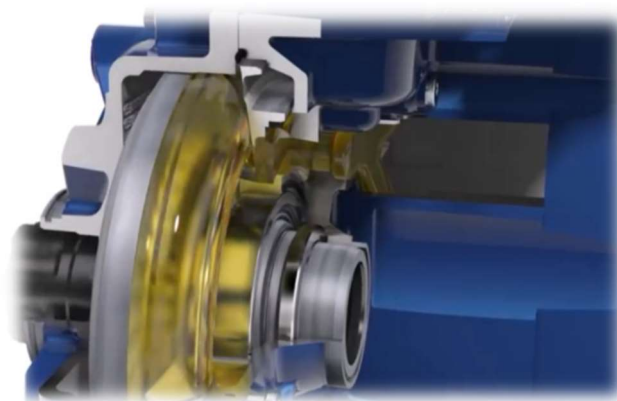

Figure 3.3. System shutdown

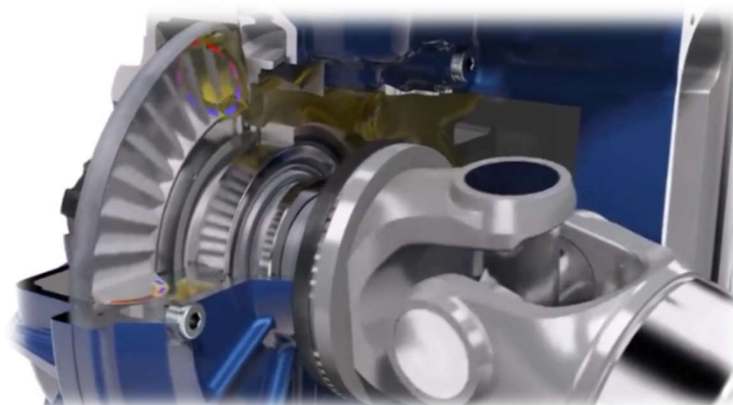

Figure 3.4. System operation

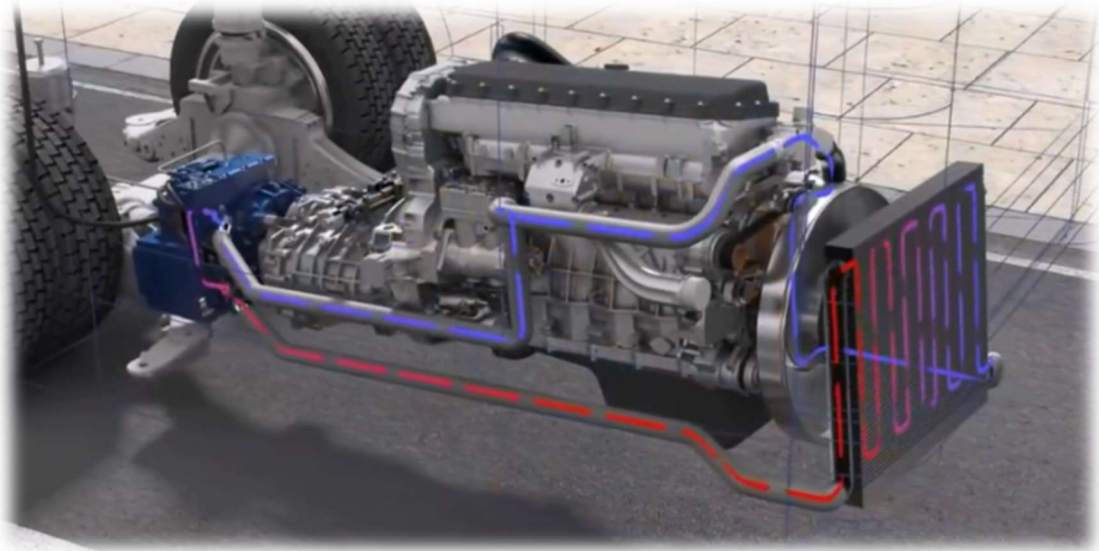

Figure 3.5. Cooling the oil

brake system in a road vehicle. Since 1950, the electromagnetic retarder has been producing and marketing under the Telma brand [28].



Figure 3.6. Electromagnetic retarder

Electromagnetic retarder consists of two rotors fixed to the propeller shaft and one stator fixed to the chassis (Figure 3.7.).

Working principle; It can be summarized as creating current in a steel mass under the influence of a magnetic field of varying intensity. These currents generated along magnetic flux lines are known as fuco currents.

The stator placed between the cardan shaft and rotating rotors is fixed to the chassis with brackets. Windings that will form alternating poles are mounted on the stator. When the speed breaker arm is activated, current flows through the windings and a magnetic field occurs on the rotors. The eddy currents and magnetic force created by this magnetic field slow down the rotor discs and the rotating cardan shaft (Figure 3.8) [30].

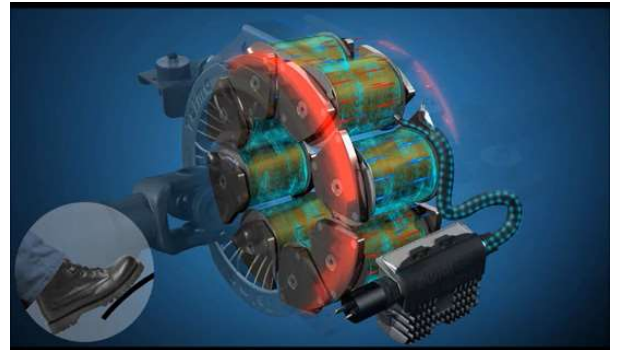

Figure 3.8. System operation

The activation of the electromagnetic retarder does not bring an additional load to the motor. These systems get the power they need from the vehicle's electrical system. In doing so, they meet within certain limits so as not to affect the actual function of the system. In addition, the

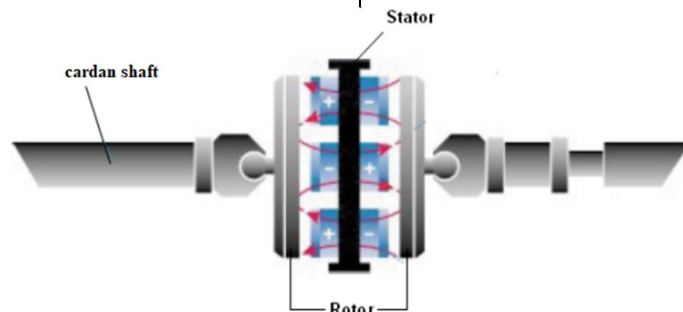

Figure 3.7. Schematic representation of the electromagnetic retarder [29]

use of this force occurs during deceleration and when the vehicle moves only under the effect of its own mass inertia.

Electromagnetic brakes have advantages such as faster brake response time, easy implementation of various control requests, fewer components and wiring, less maintenance with elimination of friction, and elimination of brake fluids [31].

4. Regenerative Brake System

The basic meaning of the word regenerative is the recovery of the spent. Of course, this doesn't mean all the energy expended. But a significant portion of it can be recovered.

In conventional braking systems, about a third of the power in the form of kinetic energy is wasted as heat during deceleration [32].

Regenerative braking is a braking method in which the kinetic energy is converted into electrical energy by using the mechanical energy in the motor and the battery is charged with the electrical energy gained. Regenerative braking is a system that allows the electric motor driving a hybrid or fully electric vehicle to generate electricity back, mainly during braking or slipping [33]. During braking, the electric motor of an electric vehicle can act as an electric generator that converts the vehicle's potential or kinetic energy into electrical energy, and the recycled energy can be stored in the battery for reuse in the vehicle [34, 35]. In an electric vehicle with gearbox, the vehicle's energy efficiency increases when the downshift is performed during regenerative braking. According to the efficiency map of the electric motor, the downshift helps to increase regenerative efficiency when the electric motor operates in the constant torque and low speed area [36, 37].

Hybrid vehicles have two types of engines, electric and gasoline. Only the electric motor runs during vehicle take-off. Two motors work together during acceleration. During fast driving, the internal combustion engine gives the real power and the electric motor supports it (Figure 4.1.).

During deceleration, the internal combustion engine stops and the battery recharges with the energy gained in the braking system.

Components in hybrid vehicles are shown in figure 4.1. Components and their functions [38];

- Battery (auxiliary): Provides electricity to start the vehicle and also powers vehicle accessories.

- DC/DC converter: Converts the high voltage DC power required to run vehicle accessories and charge the auxiliary battery from the traction battery component to DC power of lower voltage.
- Electric Generator: Generates electricity during braking from wheels and transfers it to the traction battery component.
- Electric traction motor: Activates the vehicle using power from the traction battery component.
- Exhaust system: Directs exhaust gases out of the engine.
- Fuel filler
- Fuel tank
- Internal combustion engine
- Power electronics controller: Manages the flow of electrical energy supplied by the traction battery, controlling the torque and speed of the electric motor.
- Thermal system (cooling): Maintains the proper operating temperature range of all components.
- Traction battery pack
- Transmission

Fully electric vehicles have an electric-only motor. The energy requirement of this electric motor is met by a vehicle battery with a power proportional to the power of the engine in the vehicle. As in hybrid vehicles, some of the energy consumed by the regenerative braking system is recovered in all electric vehicles (Figure 4.2).

Components in full electric vehicles are shown in figure 4.2. Components and their functions [39];

- Battery (auxiliary): Used to power vehicle accessories.
- Charge port
- DC/DC converter: Converts the high voltage DC power required to run vehicle accessories and charge the auxiliary battery from the traction battery component to DC power of lower voltage.
- Electric traction motor

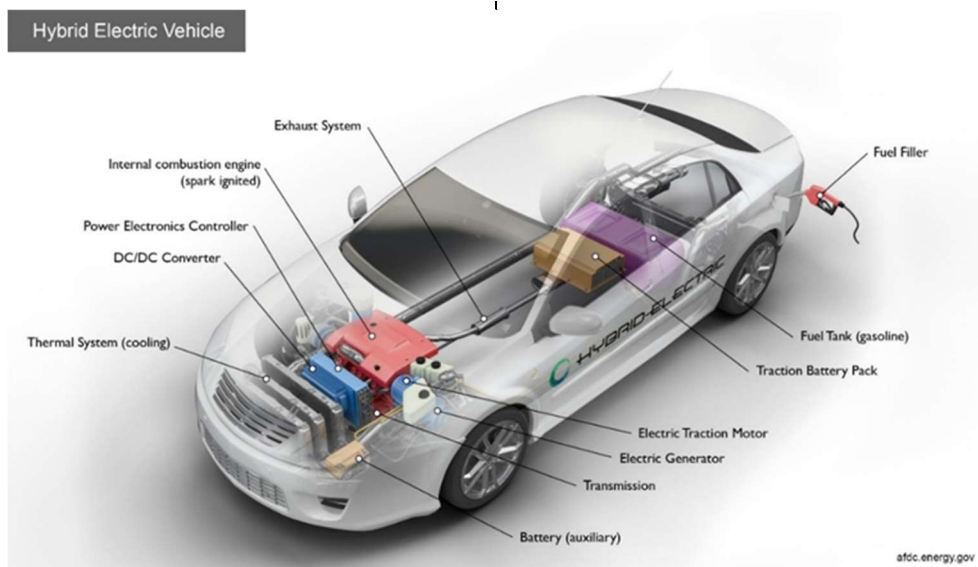

Figure 4.1. Schematic representation of an example hybrid vehicle [38]

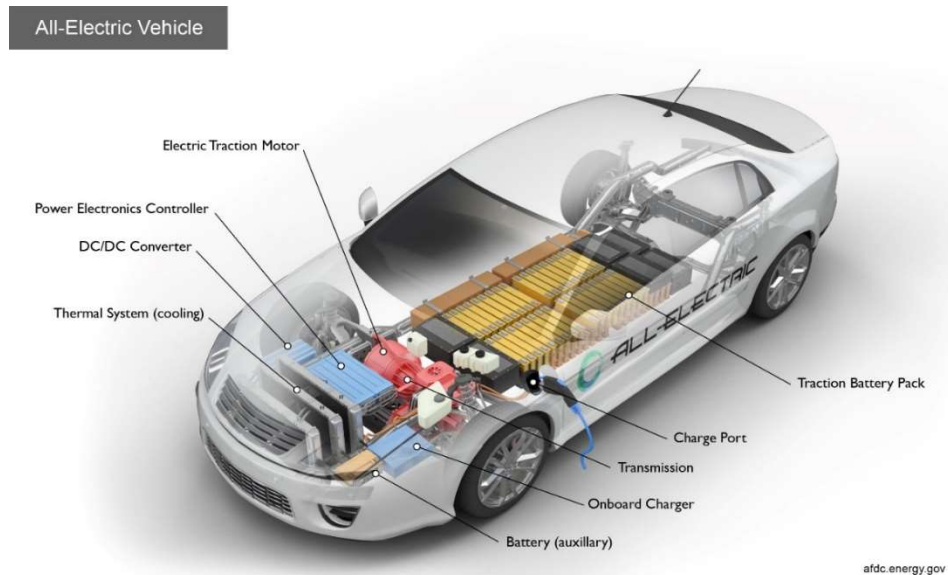

Figure 4.2. Schematic representation of the full electric vehicle [39]

- Onboard charger: Converts AC electricity to DC electricity to transfer it to the traction battery. It also monitors battery characteristics such as voltage, current, temperature and charge status during charging.
- Power electronics controller: Manages the flow of electrical energy supplied by the traction battery, controlling the torque and speed of the electric motor.
- Thermal system (cooling): Maintains the proper operating temperature range of all components.
- Traction battery pack
- Transmission

Regenerative braking is activated as soon as the accelerator pedal is released in an electric vehicle. During regenerative braking, the same induction motor acts as the alternator.

The wheels turn the rotor of the induction motor. We can already say that the rotational revolution of the rotating magnetic field in an induction motor is more than the rotor speed. To turn the motor to the alternator the rotor speed must be higher than the rotational revolution of the magnetic field.

The inverter adjusts the input power frequency so it keeps the rotating magnetic field revolution below the rotor speed. This situation causes a much higher current coming from the inverter in the stator windings. The electricity produced can be stored back in the battery after it is converted from alternating current to direct

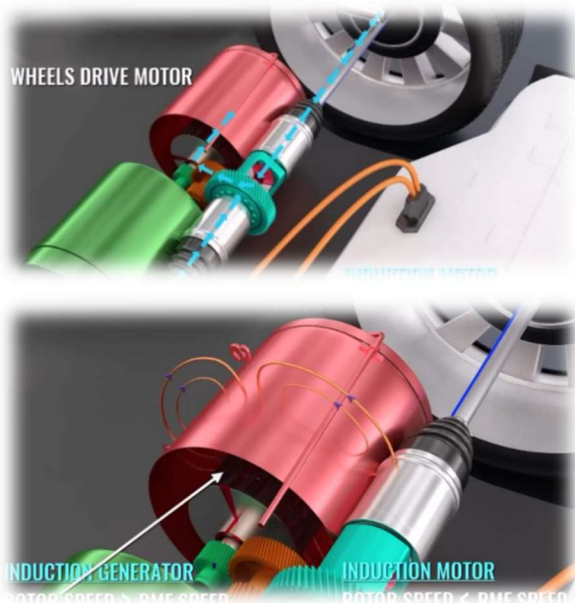

Figure 4.3. Exp. of the concept of alternator and engine

current. A magnetic force in the opposite direction to the movement of the wheels is applied to the rotor, thus slowing the vehicle.

Regenerative braking can significantly reduce vehicle emissions and increase energy efficiency [40].

References

- [1] Mutlu, I.,2002, "Seramik katkili asbestsiz otomotiv fren balatasi uretimi ve frenleme karakteristiginin deneysel incelenmesi", Doktora Tezi, Sakarya Universitesi Fen Bilimleri Enstitüsü, Sakarya.
- [2] Qu, J., Blau, P.J., Watkins, T.R., Cavin, O.B., Kulkarni, N.S.,2005, "Friction and wear of titanium alloys sliding against metal, polymer and ceramic counter faces", *Wear*, 258 (9), 1348-1356.
- [3] Krishna, G. A., & Kumar, K. S. ,2018, "Experimental investigation of influence of various parameters on permanent magnet eddy current braking system", *Materials Today: Proceedings*, 5(1), 2575-2581.
- [4] Al, T. J. M. E.,2002, "Thermal cracking in disc brakes", *Engineering Failure Analysis*, Issue 9, pp.63 – 76.
- [5] Alibelhocine, M.,2012, "Thermomechanical modelling of dry contacts in automotive disc brake", *International journal of Thermal Sciences* Vol.60, pp.161 – 170.
- [6] H.S.Qi, A. J. D.,2007, "Investigation of disc / pad interface temperatures in friction braking", *Wear*, Issue 262, pp.505 – 513.
- [7] J.Bijwe, N., N.Majumdar, B.K.Satapathy,2005, "Influence of modified phenolic resins on the fade and recovery of friction materials", *Wear*, Issue 259, pp.1068 – 1078.

- [8] P.J.Blau, J. C. M.,2003, "Tribol", *Int* 36, pp.709 – 715.
- [9] Osman Tahasen, J. T. D., Rajendra Singh,2013, "Low frequency dynamics of a translating friction element in the presence of frictional guides, as motivated by a brake vibration problem", *Journal of Sound and Vibration*, Issue 332, pp.5766 – 5788.
- [10] Dunlop Kb, R. M., Longhouse Re.,1999, "An investigative overview of automotive disc brake noise", SAE paper.
- [11] H. Hetzler, K. W.,2011, "On the influence of contact tribology on brake squeal", *Tribology International*, Vol.11, pp.237 – 246.
- [12] Kung Sw, D. K., Ballinger Rs.,2000, "Complex Eigenvalue analysis for reducing low frequency brake squeal", Technical report 2000 – 01 – 0444, Warrendale (PA).
- [13] Mario Triches Junior, S. N. Y. G., Roberto Jordan, ,2008, "Analysis of brake squeal noise using the finite element method: A parametric study", *Applied Acoustics* Vol.69, pp.147 -162.
- [14] Holmberg, K., Matthews, A.,1994, "Coating Tribology-Properties", *Techniques and Applications in Surface Engineering*, 28, pp 257-307.
- [15] Bettge, D., Starcevic J., ,2003, "Topographic properties of the contact zones of wear surfaces in disc brakes", *Wear*, 254,195-202.
- [16] Pernestål, A., Warnquist, H., & Nyberg, M.,2009, "Modeling and troubleshooting with interventions applied to an auxiliary truck braking system", *IFAC Proceedings* 42(5), 251-256.
- [17] R, L.,1992, "Brake Design and Safety", SAE International, Warrendale, PA.
- [18] Voithturbo,1999, "Voith retarder, more safety-more business with voith retarders", *Cr* 272 e, Germany, 1-14.
- [19] Kuralay, S., Yeşil, A.,2004, "Yolcu ve yük taşıyan araçlarda fren patlaması sonucu oluşan kazaların azaltılmasında teknoloji seçiminin önemi", II. Trafik Şurası, Ankara, 198-214.
- [20] Voithturbo,2004, "Voith retarder VR 115 HV for mercedes-benz actros, axor, atego", G1819 d, Germany, 1-2.
- [21] Barbieri, F. a. A., Andreatta, E. C., Argachoy, C., Brandao, H.,,2010, "Decompression Engine Brake Modeling and Design for Diesel Engine Application", *Sae Int J Engines*, 3(2).
- [22] Systems, J. V.,2018, "Introduction to engine braking", *JVS Engine Braking Intro*.
- [23] Systems, J. V.,2018, "Exhaust brakes", *Exhaust Brake Sellsheet*.
- [24] Mohammadi, F., & Alfantazi, A. ,2013, "Corrosion of ductile iron exhaust brake housing in heavy diesel engines", *Engineering Failure Analysis*, 31, 248-254.

- [25] T.J. Cooney, J. E. M.,1995, "Development of a hydraulic retarder for the Allison AT545R transmission", Int. Truck Bus Meeting Exposition 503–514.
- [26] Liu, C., Bu, W., & Wang, T.,2017, "Numerical investigation on effects of thermophysical properties on fluid flow in hydraulic retarder", International Journal of Heat and Mass Transfer, 114, 1146-1158.
- [27] Altıparmak, D.,2005, "Fren Sistemleri", ISBN 975-97419-0-3, Ankara, 1-2, 40-41.
- [28] Telma," <http://www.telma.com/en/index.php>", [Visit Date: 01.10.2020].
- [29] Telma,2001, "Telma driver's manual", TDM_9_1, USA, 1-8.
- [30] Kuralay, S., Yeşil, A., Topaç, M.M.,2004, "Yük ve Yolcu Taşıyan Araçlarda İşletme Yükünün ve Fren Patlaması Sonucu Oluşan Kazaların Azaltılması", Toplumsal Bilinçlenme Sürecinde Trafik ve İnsan Sempozyumu, Sakarya, 201-216.
- [31] Karakoc, K., Park, E. J., & Suleman, A.,2012, "Improved braking torque generation capacity of an eddy current brake with time varying magnetic fields: A numerical study", Finite elements in Analysis and Design, 59, 66-75.
- [32] Zhang J, L. C., Gou J, Et Al.,2012, "Cooperative control of regenerative braking and hydraulic braking of an electrified passenger car", Proc Inst Mech Eng, Part D: J Automob Eng, 226(10):1289–302.
- [33] Lamichhane M., Y. S., Bhetal N.,,2016-2020, "Design and Fabrication of Regenerative Braking System", Malla Reddy College of Engineering and Technology.
- [34] Ehsani M, G. Y., Emadi A,2009, "Modern electric, hybrid electric, and fuel cell vehicles: fundamentals, theory, and design", 2nd ed. CRC Press.
- [35] Hu X, J. L., Murgovski N, Egardt B.,2015, "Longevity-conscious dimensioning and power management of the hybrid energy storage system in a fuel cell hybrid electric bus", Appl Energy 137:913–24.
- [36] Li L, Y. S., Yang C, Yan B, Song J, Chen Z,2016, "Driving-behavior-aware stochastic model predictive control for plug-in hybrid electric buses", Appl Energy, 162:868–79.
- [37] Ruan, J. W. P.,2014, "Experimental verification of regenerative braking energy recovery system based on electric vehicle equipped with 2-speed DCT", In: 7th IET international conference on power electronics, machines and drives, p. 0240.
- [38] Energy, A.,"<https://afdc.energy.gov/vehicles/how-do-hybrid-electric-cars-work>", [Visit Date: 10.01.2021].
- [39] Energy, A.,"<https://afdc.energy.gov/vehicles/how-do-all-electric-cars-work>", [Visit Date: 10.01.2021].
- [40] Clarke, P., Muneer, T., & Cullinane, K.,2010, "Cutting vehicle emissions with regenerative braking", Transportation research part D: transport and environment, 15(3), 160-167.
- [41] Altındemir, E.,2008, "Hibrit elektrikli taşıtlarda rejeneratif frenleme", Yüksek Lisans Tezi, İstanbul Teknik Üniversitesi.
- [42] Bolin, G.,2009, "Simulation Study on the Matching Performance of Heavy Vehicle and Hydraulic Retarder", Jilin University.
- [43] Fama,"Auxiliary braking systems, <https://www.fama.org/wp-content/uploads/2018/01/TC033-Auxiliary-Braking-Systems.pdf>", [Visit Date: 01.10.2020].
- [44] Pandey, N., S., Khaliq, A., Zaka, Z., Saleemand, S., M., Afzal M.,,2015, "Retarder used as braking system in heavy vehicles", International Journal of Mechanical Engineering and Robotics Research.
- [45] Voith,"Retarder, https://voith.com/ita-it/brochure_1028_e_cr272_en_retarder_2014-12.pdf", [Visit Date: 01.10.2020].