

Genetic Identification of Algas on The Basis of The Analysis of 18s rRNA and rbcl of Genes Nucleotide Sequence and Development of Technology of Aquaculture Cultivation

18s rRNA ve rbcl Genlerinin Nükleotit Dizilimi Esasına Göre Alglerin Genetik Tanımlanması ve Su Ürünleri Yetiştiriciliği Teknolojisi Geliştirilmesi

Research Article

Z.B. Tekebayeva¹, A.B. Shevtsov², X.K. Rakhymzhan¹, K.A. Aituganov¹, G.A. Babayeva³, A.B. Abzhalelov¹

¹Kazakh University of Technology and Business, Astana, Kazakhstan

²National Center of Biotechnology of The Republic of Kazakhstan, Astana, Kazakhstan

³Yassawi International Kazakh-Turkish University, Faculty of Science, Dept of Biology, Turkestan, Kazakhstan

ABSTRACT

Specific identification of green microalgas, perspective as feed additive for a fry stage of fishes was carried out. The culture was identified as *Parachlorella kessleri*. Technologies of aquaculture cultivation were developed: *Parachlorella kessleri* microalga, and also zooplankton: salt-water crustacean *Artemia salina* and fresh-water crustacean *Daphnia magna* in vitro for receiving feed additives for fishes.

Key Words

Microalgas, PCR, primers, 18S rRNA, rbcl genes, food fishes, forage production, artemia, water flea, technology of cultivation, incubation, biomass

ÖZET

Yeşil mikroalglerin özgün bir şekilde tanımlanmasında, balıkların yavru aşamasında yem katkı maddesi olarak kullanımı gerçekleştirilmiştir. Kültür, *Parachlorella kessleri* olarak tanımlanmıştır. *Parachlorella kessleri* mikroalgi, ve ayrıca Zooplanktonun: tuzlu su kabuklu *Artemia salina* ve tatlı su kabuklu *Daphnia magna* in vitro balıklara yem katkı maddesi olarak kullanımı için su ürünleri yetiştiriciliği teknolojisi geliştirilmiştir.

Anahtar Kelimeler

Mikroalgler, PCR primerler, 18S rRNA, rbcl genleri, gıda balıklar, yem üretimi, artemya, su piresi, ekim teknolojisi, kuluçka, biyokütle

Article History: Received: Dec 22, 2013; Revised: Jan 5, 2014; Accepted: Mar 27, 2014; Available Online: Jun 13, 2014.

Correspondence to: G.A. Babayeva, Yassawi International Kazakh-Turkish University, Faculty of Science, Department of Biology, Turkestan, Kazakhstan.

E-Mail: gulmirababaeva@mail.ru

INTRODUCTION

For today industrial cultivation of sturgeon and other valuable trade species of fish in the Republic of Kazakhstan is only in a stage of the development. Industrial cultivation of fishes assumes also an industrial forage production which in Kazakhstan is almost brought to naught and forages for fishes are generally imported product [1].

The major limiting factor for growth and development of food fishes, even in the conditions of nurseries, is the full-fledged forage. Balance and availability of forage are especially important for individuals of a juvenile stage of development as big mortality of population is the share of this age group. Therefore, the balanced and qualitative diet of forages is one of the main conditions of profitability of fishery.

Microalgas are active producers of proteins, carbohydrates, lipids, vitamins, enzymes and mineral substances in an organic digestible form. High economic efficiency of use of microalgas consists in its richest set of biologically active agents in a digestible form for an organism of fishes. Usually the dry biomass of a microalga *Chlorella* contains 40-55% of protein, 35% of carbohydrates, 5-10% of lipids and to 10% of mineral substances [2].

Water fleas are one of the fullest on structure of forages, high protein content, a large number of microcells and vitamins, optimum amino acid composition of protein - all this does water fleas by very popular forage which enters in this or that species into the majority artificial feeding formula, including dry feeds [3].

Nauply *Artemia* are very nutritious and contain 52% of a protein and 27% of fat, carotinoid pigments, B12 vitamin (to 7,2 mkg/g). In aquaria there usually used the prepared from nauply *Artemia* starting forage for feeding thresh fishes. On fish factories it is used as a bioadditive for accumulation of weight and increase of resistance to diseases in live and dry kinds [4].

The main above-named components which will be used for preparation of biostimulating

additives on forages, are natural components of food supply of fishes, and can be used in common in different combinations and separately. However, feeding of fishes of a fry stage demands the delicate, digestible and balanced forms of forage. Researches offered by us are directed on achievement of such results.

The purpose of work was the studying of technology of aquaculture cultivation for receiving feed additives for fishes *in vitro*.

OBJECTS AND METHODS OF RESEARCH

As studied objects the green microalga of *sp. cp-4*, culture of a fresh-water crustacean *Daphnia magna* and a salt-water crustacean *Artemia salina* were used.

The identification of Microalgas has been spent on the basis of the analysis of fragments of nucleotide sequences *18S rRNA* and *rbcL* of genes. The concentration of DNA has been determined by a spectrophotometric method by using the NanoDrop spectrophotometer with a length of wave of 260 nanometers.

Amplification of a fragment *18S rRNA* and *rbcL* of genes. Reaction of PCR was executed in volume of 30 microliter. The PCR mix contained 20 ng DNA, 1 unit Taq DNA Polymerase (Fermentas), 0,2 mM of each DNTF, 1 PCR buffer (Fermentas), 2,5 mM MgCl₂, 10 pmol of each primer (Table 1). The PCR program of amplification included a long denaturation of 95°C within 4 minutes; 30 cycles: 95°C - 30 seconds, 55°C - 40 seconds, 72°C - 50 seconds; final elongation of 7 minutes at 72°C, the PCR program was executed by with application of DNA Engine Tetrad 2 Cycler PTC-0240 (Bio-Rad) Amplifier [5,6].

Cleaning of PCR products was carried out by a fermentative method, using Exo-nuclease I (Fermentas) and alkaline phosphatase (Shrimp Alkaline Phosphatase, Fermentas). A sequencing reaction was carried out with application of BigDye® Terminator v3.1 Cycle Sequencing Kit (Applied Biosystems) according to the instruction of the producer, with the subsequent division of fragments on the automatic genetic analyzer

3730xl DNA Analyzer (Applide Biosystems).

For receiving a biomass of a microalga there prepared Tamy's liquid nutrient medium, spilled in flasks and carried out strain crops with an initial caption not less than 2 million C/mL. Flasks placed on an orbital multishaker of the PSU-20i brand (Biosan, Latvia) with lighting in 2-6 thousand lx. The number of cells of microalga considered daily by means of Goryaev's camera [7]. Biomass increased within 14-20 days. Medium supervised in the rn-meter equipped with the temperature sensor.

For studying of influence of organic substances for stimulation of growth of cells of a microalga cultivation carried out in glass flasks of 250 mL at a temperature of 23-25°C . Extract from a chicken dung added in number of 5 g/L, a soil extract in number of 3 g/L [8].

Artemies cultivation was carried out using Veis's device, water fleas were grown up in a laboratory glassware.

RESULTS AND DISCUSSION

For development of feed additives for fishes the pure culture of a green microalga of sp.CP-4 was initially allocated. The specific identification was carried out by a method of definition of direct nucleotide sequence of a fragment *18S rRNA* and a fragment of *rbcl* of a gene with the subsequent determination of nucleotide identity to BLAST (<http://blast.ncbi.nlm.nih.gov/Blast.cgi>) b creation of phylogenetic trees. Results are presented in Table 1 and igure 1.

High conservatism of nucleotide sequence *18S rRNA* didn't allow to carry out specific

identification of the received culture. Use of a gene of *rbcl* as a genetic marker allowed establishing 100% identity of the received sequence with *Parachlorella kessleri*, also on a phylogenetic tree the analyzed sequence is on the same level with the given species.

A lot of literature is devoted to development of systems of cultivation of microalgas. Authors offer different types of designs, beginning from the most elementary laboratory cultivators, finishing the automated industrial systems. Usually in research establishments as laboratory cultivators the chemical ware is traditionally used [9,10].

It is possible to apply various laboratory installations to receiving small doses of a biomass of microalgas. We designed laboratory installation for receiving a biomass of microalgas of 2 l (Figure 2).

The growth and development of *Parachlorella kessleri* microalgae cells with the use of the laboratory setup shown on the chart (Figure 3).

It is established that at cultivation of a microalga of *Parachlorella kessleri* for the 14th days the quantity of cells increases by 6.4 times in comparison with initial number of cells.

Not all algas can well grow on pure mineral environments. Many of them demand for the normal growth of existence of organic substances. In that case algas grow up on medium where add various organic compounds, for example broth from peat, soils, fir-tree deposits, extracts from chicken dung, dolls of a silkworm, etc. [11].

Further we studied the influence of a soil extract and chicken extract on a gain of biomass

Table 1. The primers used for identification.

Name	Sequence 5'-3'	Reference
18S (1)	TACCTGGTTGATCCTGCCAGTA	[2]
18S (2)	ATTACCGCGGCTGCTGGCACC	[2]
rbcl (1)	ATGTCACCACAAACAGAACTAAAGC	[1]
rbcl (6)	ATTCAAATTTAATTTCTTTCC	[1]

a)

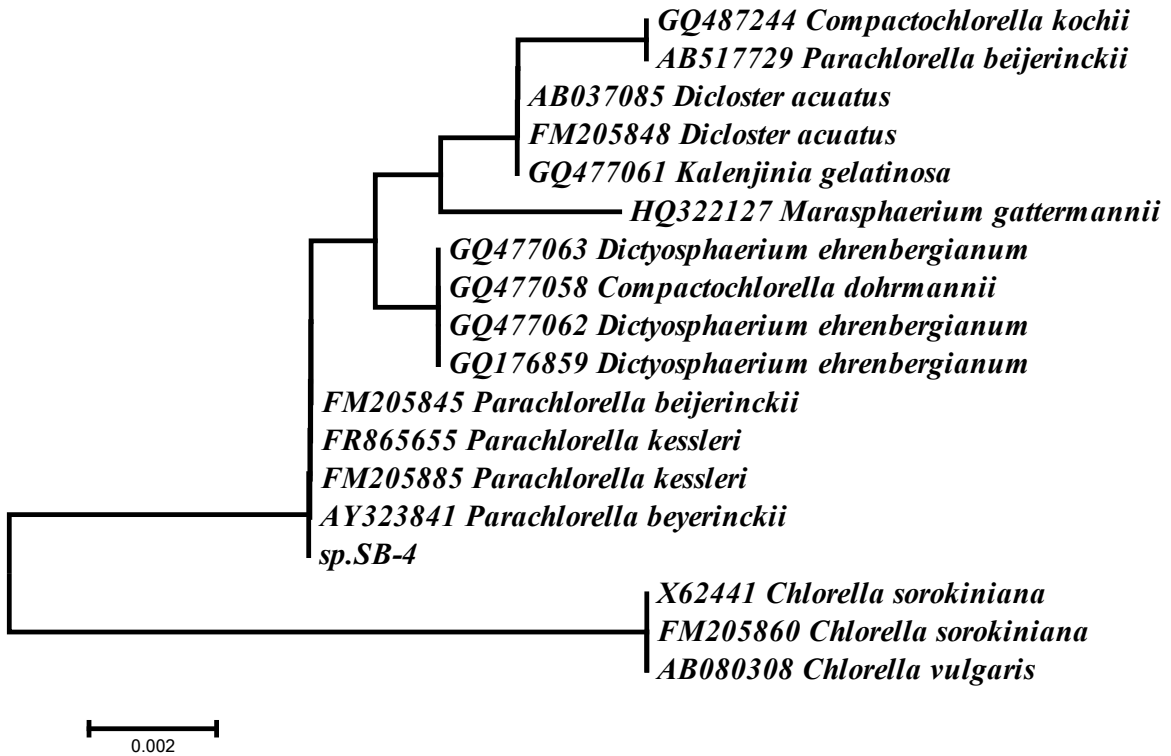

b)

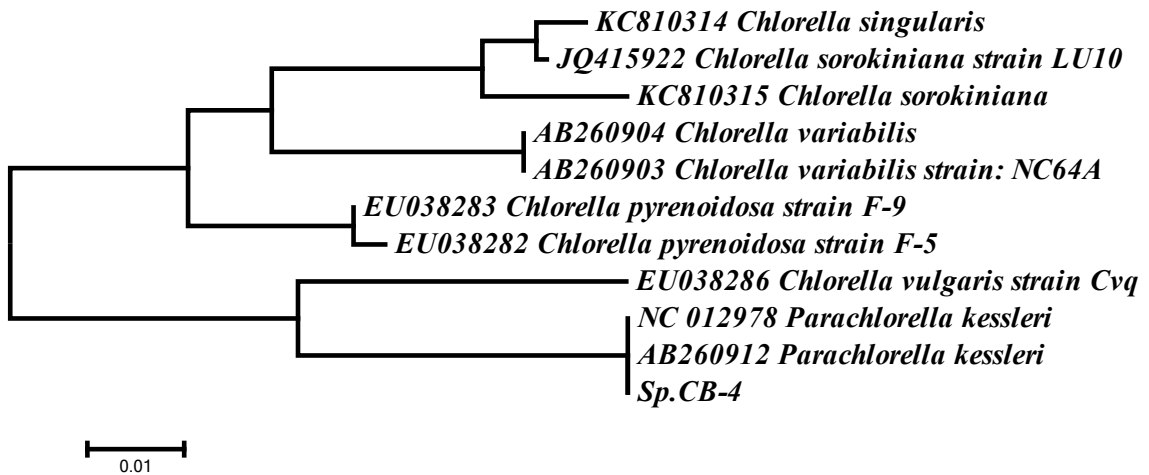

Figure 1. The phylogenetic trees constructed with use of Neighbor-joining algorithm:
a) the tree constructed on the basis of the 18S rRNA of gene analysis,
b) the tree constructed on the basis of the rbcL of gene analysis.

Table 2. Identifications by a method of the analysis of nucleotide sequence with use of various primers.

Code sample	Nucleotide sequence	Name	Identity	GeneBank
Nucleotide sequence of the fragment of the 18S rRNA gene				
Sp.CB-4	TGTCTCAAAGATTAAGCCATG-CATGTCTAAGTATAAACTGCTT-TATACTGTGAAACTGCGAATG-GCTCATTAAATCAGTTATAGTT-TATTTGATGGTACCTTACTAC-CGGATAACCGTAGTAATTC-TAGAGCTAATACGTGCGTAAATCC-CGACTTCTGGAAGGGACGTATT-TATTAGATTTAAGGCCGACCCG-GCTCTGCCGGTCTCGCGGTGAAT-CATGATAACTTCACGAATCG-CATGGCCTTGCGCCGGCGAT-GTTTCATTCAAATTTCTGCCCTAT-CAACTTTCGATGGTAGGATAGAG-GCCTACCATGGTGGTAACGGGT-GACGGAGGATTAGGTTTCGATTC-CGGAGAGGGAGCCTGAGAAACG-GTACCACATCCAAGGAAGGCAG-CAGGCGCGCAAATTACCCAATCCT-GACACAGGAGGTAGTGACAATA-AATAACAATACCGGGCCTTTTCAG-GTCTGGTAATTGGAATGAGTA-CAATCTAAACCCCTTAACGAGGAT-CAATTGGAGG	<i>Parachlorella kessleri</i>	100%	FR865655.1
		<i>Chlorella kessleri</i>	100%	X56105.1
		<i>Compactochlorella dohrmannii</i>	99%	GQ477058.1
		<i>Dictyosphaerium ehrenbergianum</i>	99%	GQ477062.1
Nucleotide sequence of the fragment of the rbcL gene				
Sp.CB-4	ACGAGCTTGATACA-CAAGCTTCAAGAGCAACACG-GTTAGCAGCAGCACCAGGAG-CATTGCCCAAGGGTGTCTA-AAGTACCACCACCAAATTGTA-AACAAGCGTCTGCACCAAA-GATTTCAACAAGAGCAGGCAT-GTGCCATACGTGAATACCAC-CAGAAGCAACAGGCATAACAC-CAGGTAGTGAAACCCAATCTT-GAGTGAATAAATACCACGAC-TACGATCTTTTTCAATGTA-ATCGTCACGCATTAATCAA-CAAAACCTAAAGTTACTTCAC-GTTCACCTTCAAGTTTACCTACAA-CAGTACCAGAATGTAATGGTCAC-CACCAGATAAACGAAAGAGCTTTG-GCTAAAACACGGAAGTGAATAC-CATGGTTTCTTTGACGGTCAATAA-CAGCATGCATTGCACGGTGAAT-GTGTAAGAAGACCATGATCAC-GACAATAAGCAGATAAACTAG-TATTTGCTGTAAAACCACAGT-TAAATAGTCGTGCATAACAATTG-GTACACCAAGTTCTTTTGACATT-GAGCAGTTTTAGCATTCTTCT-GAAGTAGCGGCAAGTGCATT-TAAATAGTGACCTTTAATTCAC-CAGTTTCAGCTTGAGATTTATA-AATAGCTTCAGCAACAATA-AGAAACGATCTCTCAACGCATA-AAAGTTGAGAGTTTACGTTTTC-GTCATCTTTGTAAAGTCAAGAC-CACCACGTAACATTCATAAA-CAGCACGACCATAGTTTTAGC-AGAAAGACCTAATTTAGGTTA-ATTGTACAACCTAAAAGAGCAC-GACCGTATTTGTTAAGTTTATCAC-GTTCAACT	<i>Parachlorella kessleri</i>	100%	FJ968741.1
		<i>Chlorella vulgaris</i>	93%	EU038286.1
		<i>Chlorella pyrenoidosa</i>	91%	EU038284.1
		<i>Chlorella pyrenoidosa z</i>	90%	EU038283.1



Figure 2. Life biomass *Parachlorella kessleri* strain.

of *Parachlorella kessleri* strain.

It is as a result revealed that addition to the medium of extract from chicken dung and a soil extract favorably influences stimulation of growth and reproduction of cells of microalgas. It is noted that for the 7th days of cultivation the increase in a biomass in 3.2 and 3.3 times respectively is observed, in comparison with initial number of cells whereas in control indicators of a gain of a biomass of cells are slightly lower.

Thus, we developed **the technology of cultivation of microalgas** in vitro which includes

the following stages:

- time of inoculum (into the flask with the medium enter the fallopian *Chlorella* culture);
- preparation of the nutrient medium Tamiya volume of about 2 L;
- introduction of inoculum *Chlorella* in cultivator with an initial density of not less than 2 million cells/mL;
- permanent counting the biomass of *Chlorella*;
- support the pH of the environment within 6 - 7, a temperature of 25-30°C;
- constant aeration, illumination not less than 1-2 thousand Lux.;
- it is possible to add organic substances (soil extracts or extract from the chicken dung) to accelerate the growth and development of cells *Chlorella*;
- if all the conditions of cultivation fourteen days suspension *Chlorella* is ready for use.

One of the most perspective representatives of a zooplankton used for industrial cultivation are crustaceans of the *Crustaceae* class - water flea and *Artemy* who serve as objects of live forages for fishes [9].

For an incubation of *Artemies* eggs many devices are offered. One of the elementary and very convenient one in work is the Veis's ordinary device interfaced to system of supply of compressed air.

We designed a cultivator like Veis's device for an incubation of eggs *Artemy* (Figure 4) of 5 L. For an incubation the eggs were used which previously have been exposed to frost in saturated salt

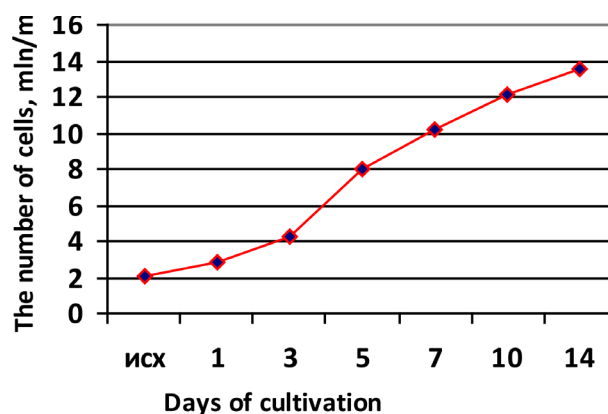

Figure 3. Dynamics of growth of *Parachlorella kessleri* strain cells.



Figure 4. Cultivator for *Artemia* egg incubation.

solution within 3 months. A previously defended tap water filled in a cultivator and brought 120-125 g of salt of chloride of sodium and 10-12 g of *Artemia* eggs on 5 l of the medium. Medium has to be within 7.5 - 8, temperature not less than 25-28°C since at its fall eggs hatching speed decreases, worsens viability. To an incubator the round-the-clock lighting by luminescent lamps about 1000 lx and active aeration by means of the compressor are carried out. The purge provides with the compressed air enrichment of the incubatory medium by oxygen, fast removal of being formed carbonic acid, it doesn't allow accumulation of products of a metabolism in the microzones surrounding eggs, prevents subsidence of eggs at the bottom of a vessel and creation in a layer of the settled eggs of anaerobic conditions.

Thus, we developed **the technology of *Artemia* cultivation** including the following stages:

- activation of eggs by a freezing at -20-25°C in saturated solution of salt not less than 1 month;
- preparation of the incubatory medium as follows on 5 L of the defended tap water we take 120-125 g of salt of chloride of sodium;
- laying of eggs in an incubator - on 5 L 10-12 g of *Artemia* eggs;
- continuous intensive aeration by means of

the compressor;

- temperature maintenance within 25-28 °C;
- continuous control medium within 7.5-8, illumination not less than 1000 lx;
- under favorable conditions in 24-36 hours naupliya hatching occurs;
- after full naupliya hatching it doesn't need aeration, the compressor is disconnected;
- for 3-4 day it is necessary to feed up *Artemia* by solution of yeast;
- since 5-6 days fed *Artemia* suspension of the unicellular green Alga *Chlorella*;
- for 15-20 days *Artemias* increase in sizes up to 10-12 mm.

The technology of cultivation of water fleas

doesn't demand special devices; it is enough to contain them in glass or plastic vessels (Figure 4) and to meet the following conditions:

- culture of water fleas cultivate in the tap water which has settled not less than 7 days;
- optimum temperature conditions of 20-22°C;
- optimum = 7 - 8;
- aeration isn't required;
- rather light lighting of 12-14 hours in day;
- small water fleas feed with a liquid barmy forage;
- adult *Daphnia* feeding suspension of the unicellular green Alga *Chlorella*;
- the water should be changed to the extent of contamination;
- during cultivation *Daphnia* increases from 1 mm to 4.5 mm.

CONCLUSION

In the course of performing this work, the following results are received:

- specific identification of a green microalga by a method of definition of direct nucleotide sequence of two fragments 18S of rRNA and rbcL of genes with the sequences deposited in the international Gene Bank database is carried out. The strain is identified as *Parachlorella kessleri*;
- the technology of cultivation of microalgas in vitro is developed;
- the technology of *Artemia* cultivation on laboratory installation of own design is developed;
- the technology of cultivation of *Daphnia* in laboratory conditions is developed.

References

1. The Concept of Development of Fishery of the Republic of Kazakhstan for 2007-2015 (The Resolution of the Government of the Republic of Kazakhstan of October 6, 2006 N 963).
2. S.P. Vasser, N.V. Kondrat'yeva, N.P. Masyuk, A.O. Vodorosli Spravochnik, Kiev, Naukova dumka (1989) 605.
3. I.V. Ivleva, Biological bases and methods of mass cultivation of fodder invertebrates, Moskva: Nauka, (1969) 171.
4. G.T. Buzmakov, A.D. Polyakov, Zoology: biology and cultivation invertebrates / Successes of modern natural sciences, N2, (2010) 14-16.
5. J.R. Manhart, Phylogenetic analysis of green plant rbcL sequences. Molecular Phylogenetics and Evolution, 3 (1994) 114-127.
6. K. Kuznedelov, O. Timoshkin, V. Kumarev, Molecular phylogeny of planarians (Turbellaria, Tricladida, Paludicola) of Lake Baikal established by comparative analysis of the nucleotide sequences of 18S ribosomal RNAs, Mol. Biol. (Moscow), 30 (1996) 1316-1325.
7. L.A. Sirenko, A.I. Sakevich, L.F. Osipov, L.F. Lukina, M.I. Kuz'menko, V.N. Kozitskaya, I.M. Velichko, V.O. Myslovich, M.Y. Gavrilenko, V.V. Arendarchuk, Y.A. Kirpenko, Methods of fiziologo-biochemical research of algae in hydrobiological practice, Kiev: Naukova dumka, (1975) 247.
8. A.M. Muzafarov, T.T. Taubayev, Cultivation and application of microalgas, Tashkent: Fan, (1984) 40-41. (Muzafarov A.M., Taubayev T.T.).
9. V.I. Uspenskaya, Ecology and physiology of freshwater algae nutrition, Moscow: MGU, 1966. -124 p. (Uspenskaya V.I.).
10. E.G. Pringsheim, Bakterien und Cyanophyceen Ubereinstimmungen und Unterschiede, - Z.Osterr. bot., (1967) 114.
11. V.D. Romanenko, Y.G. Krot, L.A. Sirenko, V.D. Solomatina, Biotechnology of cultivation of hydrobionts, Kiev, (1999) 264.