

# 4 Wheel Steering System Control Unit Design

Aynur Tuba Çakmak, Ergun Erçelebi

**Abstract**— Ease of driving and flexibility in movements are very important for the developing automobile technology today. The aim of the study is to provide convenience to the driver by trying different modes in the steering system of a vehicle. In this study, an electronic board has been designed for the steering system for the 4 wheels in the vehicle. The card developed in the study provides choosing from 3 different modes as standard, circle and crab to driver. The driver will have the advantage of both comfort and safe driving with the mode chosen according to the road and load conditions. Also, the 4-wheel steering system improves handling stability and active safety at high speeds. Using 4-wheel steering at low speeds can reduce the turning radius on the steering wheel for more convenient maneuvers. Positive feedback was received from drivers who tried the card on heavy-duty vehicles. Tests continue on different heavy-duty vehicles. If the electronic board and software do not perform as expected in different heavy vehicles, improvements will be made in the design. However, the results obtained so far are satisfactory. It shows good response performances, also improves ride quality and stability.

**Index Terms**— Electronics control unit design, Steering system, 4-Wheel steering.

## I. INTRODUCTION

NOWADAYS the competition among automobile manufacturers all over the world and the awareness of consumers have led to the need to produce more perfect vehicles. In the design of a vehicle, frame features (wind resistance coefficient, shape, viewing angles, etc.), interior comfort (air conditioning, electric windows, electric control seats, etc.) workmanship quality (application of leather upholstery, plastic quality used in the console, trim success, etc. and safety accessories (airbag, inside door protection bars, ABS, etc.) constitute important criteria. Many cars produced today have most of the features listed above. In past, the variety of accessories is a dominant factor in the sale of a car. Nowadays the health and safety of drivers and passengers has become crucial and a step further. Automobile road safety criteria have been established by independent organizations and decisions are made by these organizations, whether the automobile will be produced or not due to tests [1].

**AYNUR TUBA ÇAKMAK**, is with Department of Electrical Engineering University of Gaziantep University, Gaziantep, Turkey, (e-mail: [aynurtubacakmak@gmail.com](mailto:aynurtubacakmak@gmail.com)).

 <https://orcid.org/0000-0003-0083-3371>

**ERGUN ERÇELEBİ**, is with Department of Electrical Engineering University of Gaziantep University, Gaziantep, Turkey, (e-mail: [ercelebi@gantep.edu.tr](mailto:ercelebi@gantep.edu.tr)).

 <https://orcid.org/0000-0002-4289-7026>

Manuscript received July 10, 2021; accepted May 23, 2022.  
DOI: [10.17694/bajece.969569](https://doi.org/10.17694/bajece.969569)

In the developing technology age, it is seen that many studies have been carried out to develop mechanical and electronic systems. Wheel steering systems have had their share in this development process. Many methods have been developed and studied to increase the flexibility of movements in wheel steering systems.

Wheel steering systems are a defining part for whole vehicle styles. It shows the link among vehicle and driver. Its primary mission is to direct a vehicle in the wanted path securely and under exact control. Owing to the significance of the steering system, it must be secure and basic [2]. Conventional steering system design is usually done mechanically.

Thanks to growth of control and electronic technologies, the four-wheel steering (4WS) system has been researched as a vehicle maneuvering technique that increases the maneuverability of vehicles at low velocities and improves their determination at high velocities. On account of increase control efficiency, since the first 4WS system was important, much work has been given to the control strategies of the 4WS system, especially the steering stability controller project, which has been an investigate subject of interest in recent years. It is also well known that processing stability control with different unknowns is a complicated and nonlinear process [3].

To reduce the cornering radius, the rear wheels should be turned in the opposite direction to the front wheels at low speeds. If the rear wheels turn in identical direction as the front wheel, it improves the vehicle's ability to change lanes and stability at medium and high speeds. One of the major advantages of all-wheel steering is the resetting of the lean angle and the other is to increase the dynamic response capability. Theoretical studies show that when the steering angle of the rear wheels is the only control data, the four-wheel steering cannot properly follow the yaw and lateral acceleration. Particularly high speed cornering, with the constant yaw of the vehicle steered by four wheels, its front wheels are less than the yaw of the steered vehicle. Therefore, a greater wheel steering angle is required for the similar bend radius, which enhances the user's work.

Stanislav et al. [4] examined the simulation and modeling of a land-road vehicle with a 4WS system. In the study, it was aimed to develop a steering system that provides driving safety, maneuverability and driving quality. Their result is that the vehicle with the 4WS has preferable maneuverability when the rear wheels are steered in the reverse direction to the front than when steering from the front.

Li et al. [5] worked by testing the absence of classic 4WS. With the help of CarSim's and Matlab / Simulink programs, the simulation of the proposed control system was created and

evaluated. The simulation conclusions indicate that with the designed 4-wheel active steering (4WAS) controller, good response performances could be achieved, and could be improved quality and stability of the ride.

Barec et al. [6] developed a control system for four-wheel steering vehicles. Then, they created a sample of the vehicle with 4WAS on a scale of 1: 5 to test this system. As a result of these samples, the yaw velocity and lateral acceleration can be adjusted.

Yi et al. [7] developed a rear-wheel steering (RWS) control algorithm to improve vehicle usage success with no need for tire features. The algorithm has been examined through computer simulations. The simulation has been tested for step steering and waiting for sinus scenarios under different road friction cases. Simulation results showed that the tried algorithm caused an increase in vehicle driving performance.

When the studies in the literature are examined, it is seen that the studies are generally done on simulation programs or scaled models. The results obtained indicate that it increases driving comfort and security.

In this study, the 4WS electronic card, which can be used especially in work machines, has been designed and tested on work machines. In the literature, the advantages and disadvantages of using the 4-wheel steering process, which is usually done on simulation and used in cars, on work machines have been investigated.

II. PROPOSED METHOD

The turn control system receives feed from the oil of the P2 pump through the priority valve shown in Fig. 1 The priority valve also acts as a flow control valve, managed by the load signal (LS) pressure from the turn orbital valve. With the increase of the load in the turn circuit, the load signal pressure affecting the priority valve increases and more oil is sent to the turn circuit. With the decrease of the load signal pressure, less goes from the priority valve to the turn circuit.

This valve is used to turn the rear wheels to the right / left in order to increase manoeuvrability in machines with large front wheels. With the multi-purpose turn control valve, the operator can operate the machine in the following turn modes with the

selection made from the turn mode selection switch in the cabin:

- Standard Turn Mode: In this mode, only the front axle moves either clockwise or counter clockwise and the rear wheel does not. This is the drive that we see in day to day life in all the four wheelers. It is generally used at moderate speed.
- Circle Turn Mode: In this mode, both the front and rear axles move in opposite directions relative to each other. Since both axles move in different directions, the radius of curvature decreases during turning. This drive is mainly used during parking of the vehicle. This means the vehicle will require less space for parking and this will be helpful in places where traffic and parking is a major problem. [8]
- Crab Turn Mode: In this mode, the front and rear axle wheels of the machine turn to the same side. In this mode, the machine crab walks. This drive enabled vehicle to change the lane during highway driving. It is generally applied at higher speed. [9]

Fig. 2. shows the positions of the wheels according to the modes as described above.

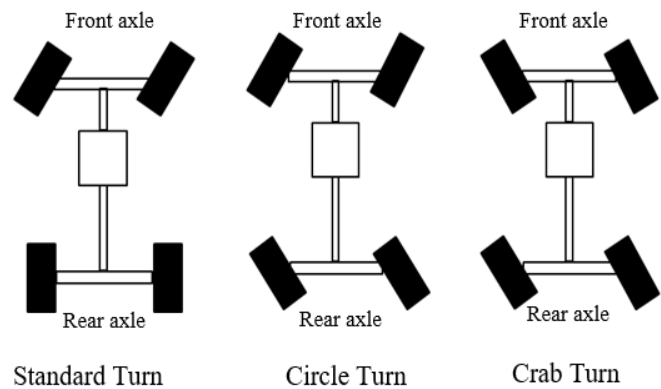

Fig.2. System with turn circuit 4WS

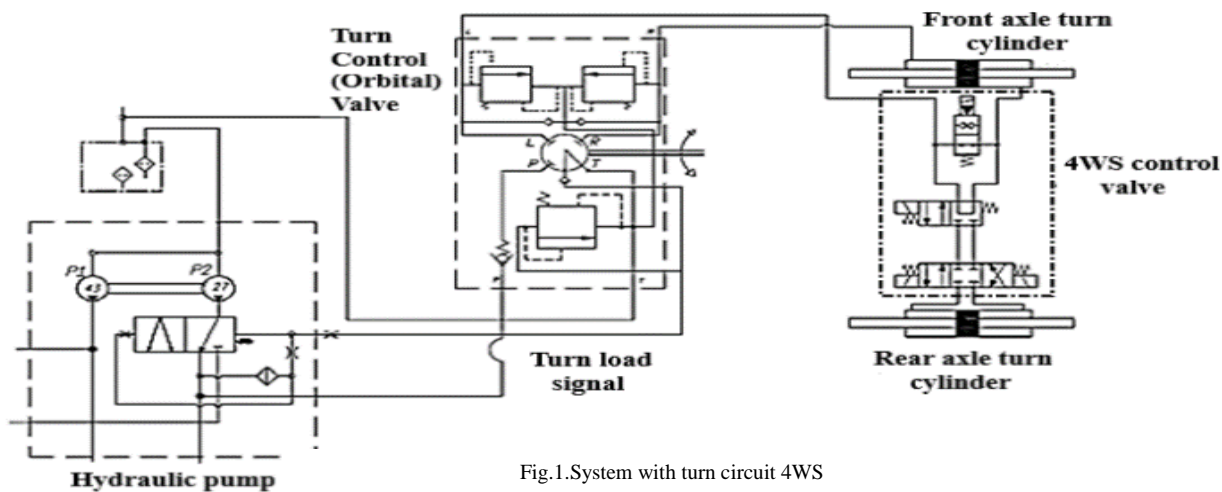

Fig.1.System with turn circuit 4WS

III. DESIGN OF CONTROL UNIT 4WS ELECTRONIC

In Fig.3., turn system electric circuit shows the Y20 turn solenoid, the Y21 rear axle turn solenoid, the Y22 circle turn solenoid and the Y24 crab turn solenoid.

understandable and suitable for future developments. AMP-346350-5 (PCB Connector) [10] has been utilized to communicate between the gearbox and the circuit board.

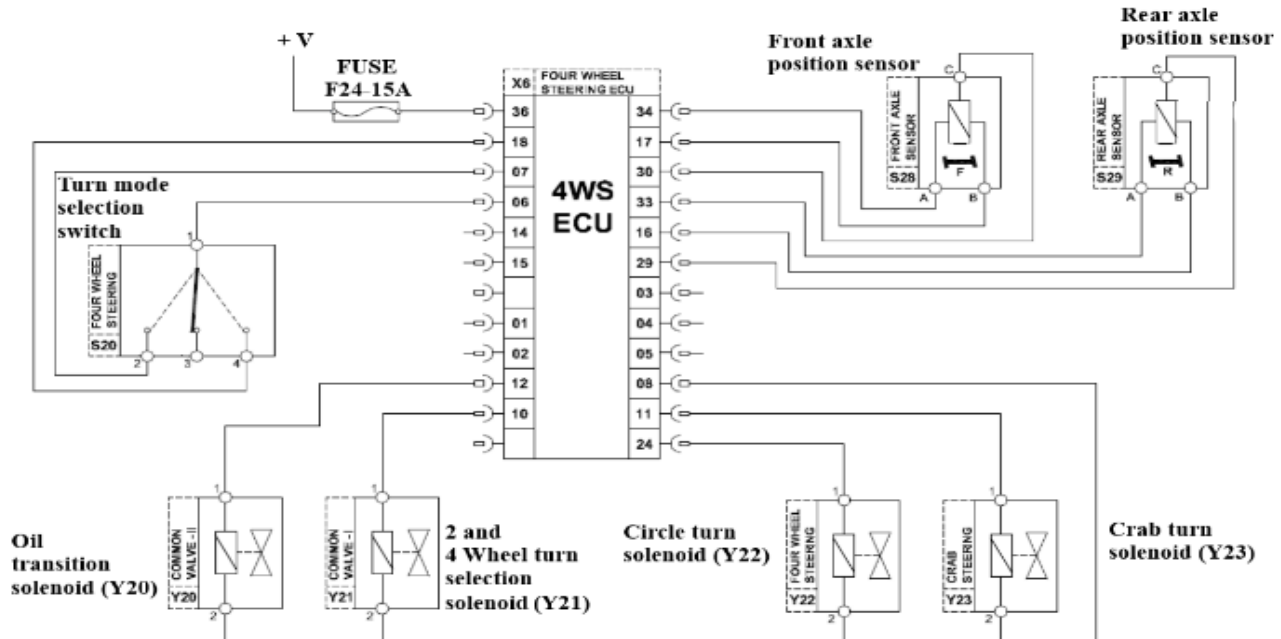

Fig.3. Electrical circuit diagram of turn system

Standard Turn Mode: In this mode, all solenoids are in the off state. Oil from the turn control valve goes directly to one side of the front axle cylinder and to the other through the Y20 and Y21 solenoid valves. No oil goes to the rear axle turn cylinder. Thus, in this mode, only the front axle wheels turn when the operator turns the steering wheel.

Circle Turn Mode: In this mode, Y20, Y21 and Y22 solenoid valves are energized (ON). With the energization of the Y20 and Y21 solenoids, the left side of the front axle turn cylinder is connected to the Y22, Y23 solenoid valve group. In this mode, when the machine turns right with the energization of the circle turn Y22 solenoid, the oil coming out from the left side of the front axle cylinder goes to the left side of the rear axle cylinder. While the machine rotates to the left, the oil flow between the axle cylinders occurs in the opposite direction.

Crab Turn Mode: In this mode, Y20, Y21 and Y23 solenoid valves are energized (ON). With the energization of the Y20 and Y21 solenoids, the left side of the front axle turn cylinder is connected to the Y22, Y23 solenoid valve group. In this mode, with the energization of the crab turn Y23 solenoid, the front wheels turn right, while the oil from the left side of the front axle cylinder goes to the right side of the rear axle cylinder. While the front wheels turn to the left, the oil flow between the axle cylinders occurs in the opposite direction. The card seen in Fig.4. was designed in the EAGLE program and the PCB drawing was made in the same program. Esp-12 Wi-Fi module has been used to communicate with the card remotely. As a processor, the ATmega32U4 has been preferred because it provides sufficient input and output, which is affordable, and easily accessible. The C computer language was used to program the processor and it was compiled using the Arduino interface. The codes were tried to be written as simple,

IV. MEASURED RESULTS

A. Electrical Tests of 4WS ECU

Measurements are performed at laboratories by using multimeter. The designed card has 12V voltage, 11A current and 132W power dissipation. The measured results of the 4WS ECU are shown in Table 1.

TABLE I  
MEASURED RESULTS OF THE 4WS ECU

Rating	Measured
Voltage	12V
Curent	11A
Power	132W

The operating temperature range is -15 degrees C to 85 degrees C. The operating temperature is shown in Table 2.

TABLE II  
OPERATING TEMPERATURE OF THE 4WS ECU

Rating	Max.	Min.
Operating Temperature	-15 °C	85 °C

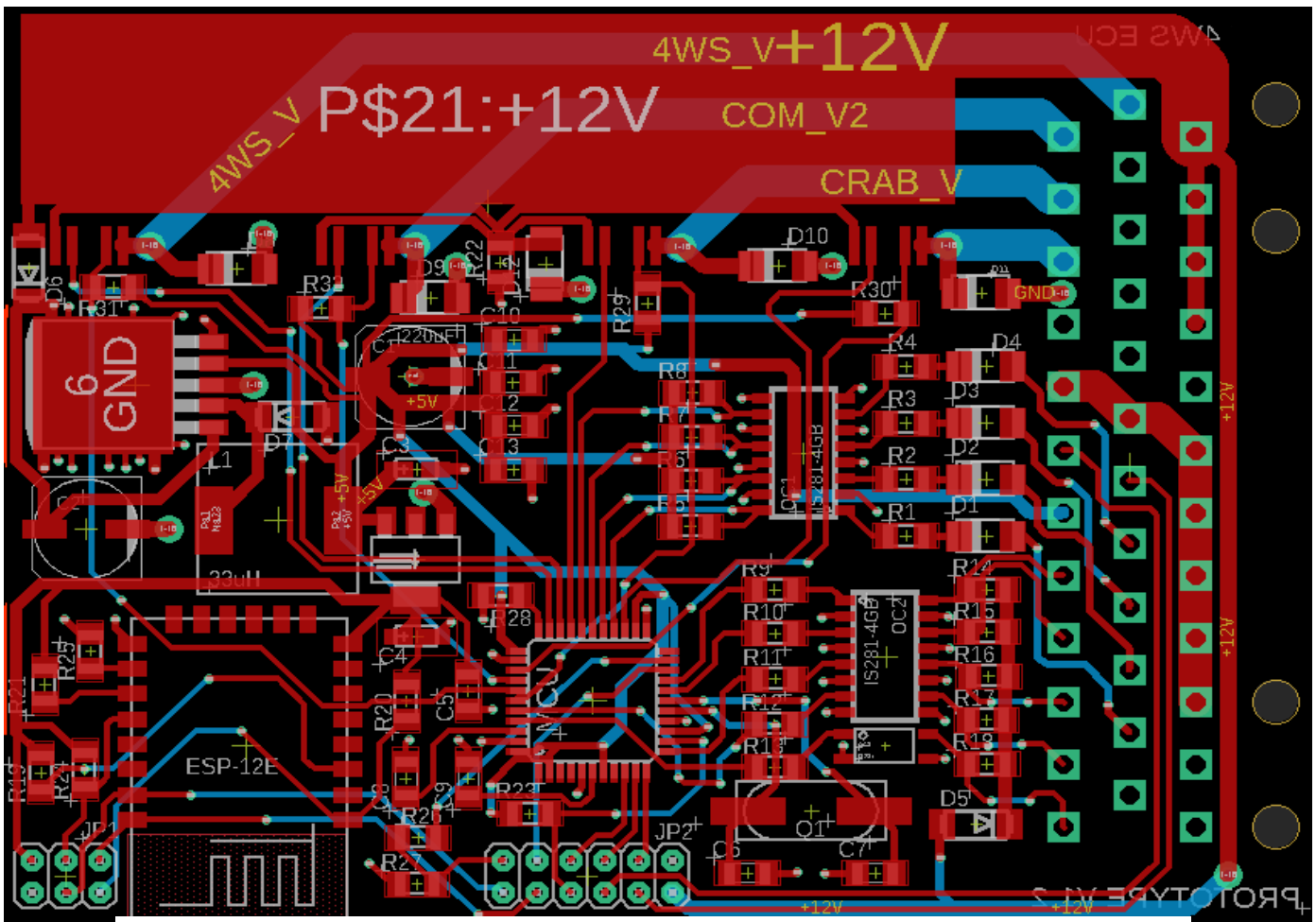

Fig.4. 4WS eagle schematic



Fig.5. Work machine with 4WS ECU

4ws card was attached to the work machine with the help of connector to obtain electrical test results. The set up can be seen in Fig.5.

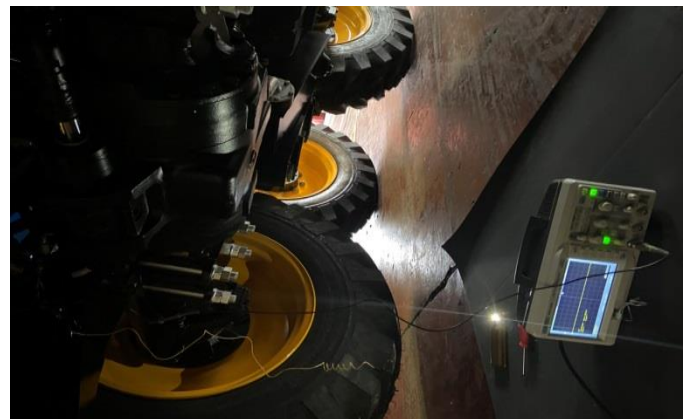

Fig.6. Measurement setup

The measurements are performed at factory by using oscilloscope. First, the signal input and GND ports of the oscilloscope are connected to the 4WS ECU. The set up can be seen in Fig.6.



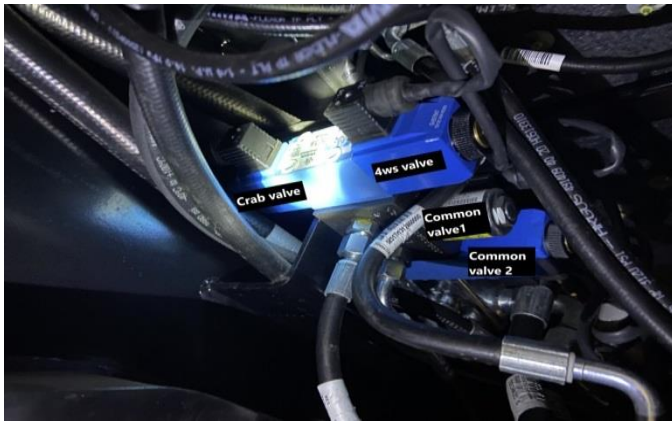

Fig.7. Condition of valves in standard rotation mode

If standard rotation mode is selected when the machine is activated, all solenoids are in the off state. The set up can be seen in Fig.7.

The solenoids output voltages were measured as 0V, the screen shot can be seen in Fig.8.

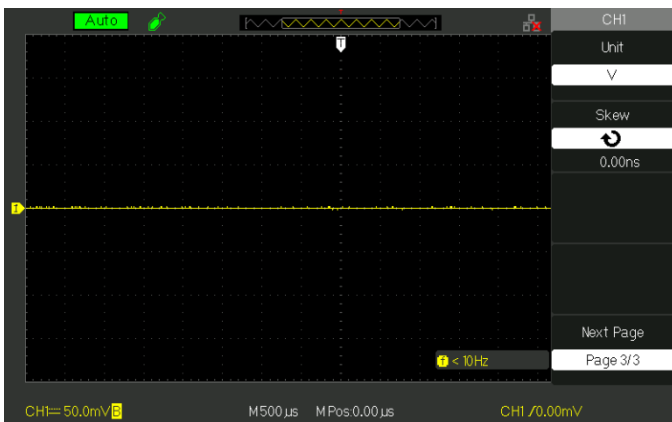

Fig.8. Output Voltages of the all solenoid valves in the standard rotation mode

If circle rotation mode is selected when the machine is activated, 4ws, common valve 1 and common valve 2 solenoid valves are energized (ON). The set up can be seen in Fig.9.

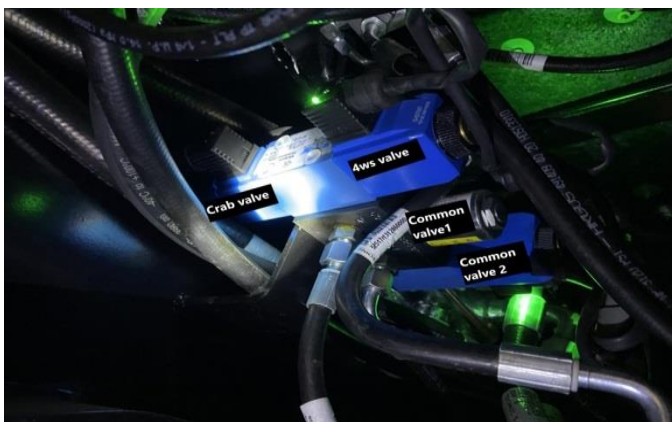

Fig.9. Condition of valves in circle rotation mode

The 4ws valve, common valve 1 and common valve 2 output voltages were measured as 12V when crab valve output voltage was measured as 0V in circle rotation mode, the screen shots can be seen in Fig.10.and Fig.11.

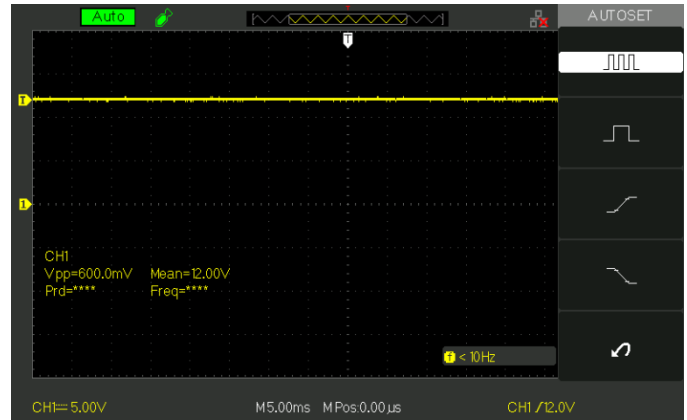

Fig.10. Output voltages of the 4ws, common valve 1 and common valve 2 solenoid valves in the circle rotation mode

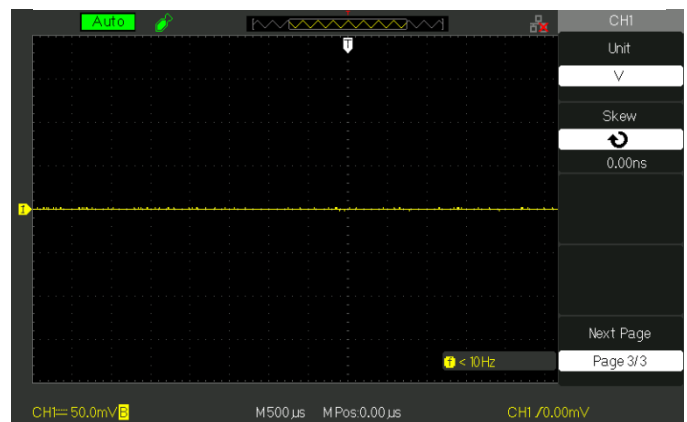

Fig.11. Output voltages of the crab solenoid valve in the circle rotation mode

If crab rotation mode is selected when the machine is activated, crab, common valve 1 and common valve 2 solenoid valves are energized (ON). The set up can be seen in Fig.12.



Fig.12. Condition of valves in crab rotation mode

The crab valve, common valve 1 and common valve 2 output voltages were measured as 12V when 4ws valve output voltage was measured as 0V in the crab rotation mode, the screen shots can be seen in Fig.13.and Fig.14.

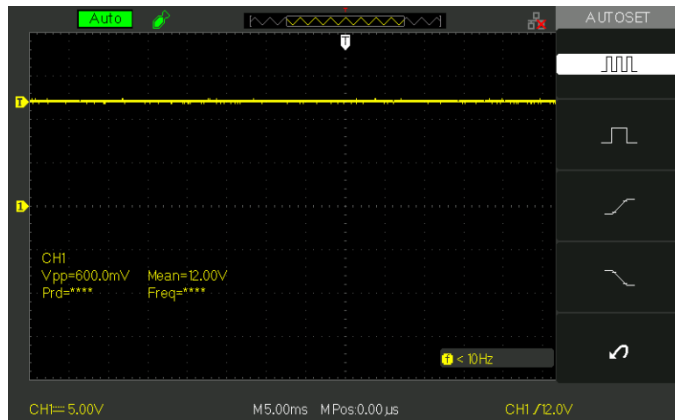

Fig.13. Output voltages of the crab valve, common valve 1 and common valve 2 in the crab rotation mode

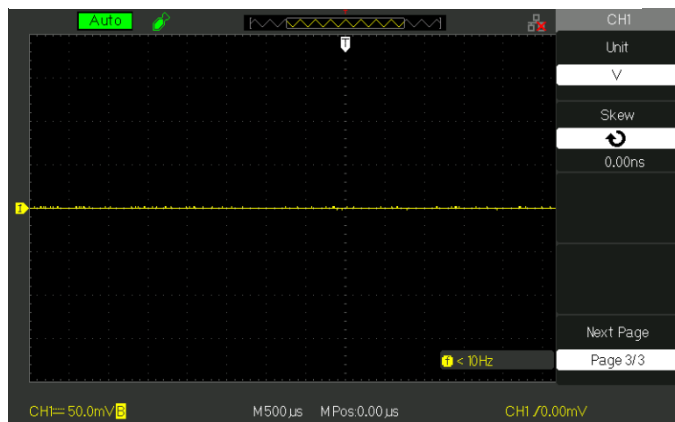

Fig.14. Output voltages of the 4ws valve in the crab rotation mode

### B. Experimental Results

In order to test the 4WS card, work machines with and without the 4WS card installed, closed the one-kilometer channel with the same driver (loading, unloading and pushing the sand into the channel). As a result of these same procedures, the required labor hours, and the required fuels were calculated and the required maintenance periods in the annual period are shown in Table III.

TABLE III  
OPERATING TEMPERATURE OF THE 4WS ECU

Type of Vehicle	Process completion time	Fuel consumption amount	Number of annual maintenance
With 4WS	3 hours	24 liters	4 times
Without 4WS	5 hours	35 liters	2 times

According to Table 3, fuel consumption and completion time are decreasing since maintenance time of the valves is increasing.

### V. CONCLUSIONS AND RECOMMENDATIONS

Throughout the study, the requirements of the 4WS system were decided initially. Turn control valve and multipurpose turn control valve were selected according to these requirements. After the pre-feasibility and preliminary computation are finished, the 4WS system has been designed. Mechanical and electronic parts of the system have been described. The system was first designed with EAGLE. After the modeling is completed, the assembly of the prototype electronic card has been completed and the accuracy of the parts has been tested. Then, the software of the vehicle was completed to perform field tests and the conclusions on the field were observed. It was observed that the system was working appropriately by drivers. During the study, activities concerned to the 4WS system are included. 4WS system has been approved by testing the studies in the field as an academic and a real system.

Figure 15 shows the prototype and first version V1.1 of the card.

Benefits of the system:

- Car more efficient and stable on cornering.
- Improved steering responsiveness and precision.
- Notable improvement in rapid, easier, safer lane changing maneuvers.
- Smaller turning radius and tight space maneuverability at low speed.
- Relative Wheel Angles and their Control.
- Risk of hitting an obstacle is greatly reduced.

The system, designed to increase the safety and comfort of vehicles, is currently being actively used and tested. Security vulnerabilities related to rotations are found in the machines, and efforts are made to solve the problems. With this project, the fact that the software and hardware are under our own control, with the great advantages it provides in terms of cost, and changes and developments have become easier. Today, new approaches are emerging in line with the increasing demands for safety in vehicles and transport systems. Among these studies, autonomous vehicles and their applications come to the fore. Autonomous vehicle applications, which gain more importance and become widespread day by day, are considered as the vehicles of the future. For this reason, in this research study, general information about wheel steering applications, which has an important role in vehicles, has been given and an electronic board design has been made. Although these systems exist to support the driver for the time being, it is predicted that the driver will soon support these systems, and even the driver will be able to travel and use them without looking at the road in the vehicle. With the card designed in this study, it is thought that future studies will be carried out on topics such as artificial intelligence and data mining, which are popular today. Starting with the main major problems, modifications and improvements are made on the board to find the best suitable solution. Last word, the card developed in this study was being imported. With the use of the card in vehicles, it will reduce imports and contribute to the country's economy. The card was developed within the scope of university and industry cooperation.

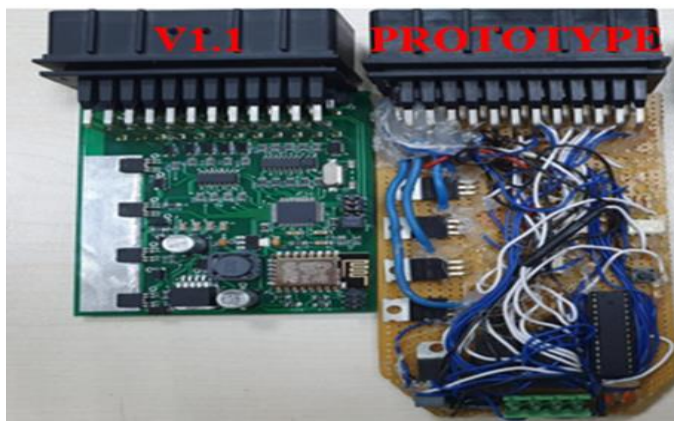

Fig.15. 4WS ECU V1.1. and prototype



**ERGUN ERÇELEBİ** received B.S. degree in Electrical and Electronics Engineering from METU, Gaziantep, Turkey in 1990 and M.S. and Ph.D. degrees in Electrical and Gaziantep in 1992 and 1999 respectively. Since 2011, he has been a Professor with the Electrical and Electronics Engineering Department at University of Gaziantep in Gaziantep, Turkey. Since 2014, he has been the head of the Electrical and Electronics Engineering Department. His research interests include embedded systems, signal processing and artificial neural networks.

#### REFERENCES

- [1] A.A.Sarioğlu (2002). Taşıtlar Yanal Kayma ve Kontrolü, (Master dissertation, Institute of Science, Istanbul University).
- [2] Lajqi, S. (2013). Suspension and Steering System Development of a Four Wheel Drive and Four Wheel Steered Terrain Vehicle (Doctoral dissertation, Univerza v Mariboru (Slovenia)).
- [3] Xu, F. X., Liu, X. H., Chen, W., Zhou, C., & Cao, B. W. (2019). Improving handling stability performance of four-wheel steering vehicle based on the  $H_2/H_\infty$  robust control. *Applied Sciences*, 9(5), 857.
- [4] Pehan, S., Lajqi, S., Pšeničnik, J., & Flašker, J. (2011). Modeling and simulation of off road vehicle with four wheel steering. In *IRMES Conference Proceedings* (pp. 77-83).
- [5] Li, B., & Yu, F. (2009, June). Optimal model following control of four-wheel active steering vehicle. In *2009 International Conference on Information and Automation* (pp. 881-886). IEEE.
- [6] Barec, P., Maly, M., & Vozenilek, R. (2004, October). Control System of Vehicle Model with Four Wheels Steering (4WS). In *International Scientific Meeting Motor Vehicles and Engines* (pp. 1-7).
- [7] Park, K., Joa, E., Yi, K., & Yoon, Y. (2020). Rear-Wheel Steering Control for Enhanced Steady-State and Transient Vehicle Handling Characteristics. *IEEE Access*, 8, 149282-149300.
- [8] Tim Gilles (2014), "Automotive Service Inspection, Maintenance, Repair".
- [9] Jack Erjavec (2009), "Automotive Technology—A System Approach", Cengage Learning, 5th Edition.
- [10] <https://www.te.com/usa-en/product-346350-5.html>

#### BIOGRAPHIES



**AYNUR TUBA ÇAKMAK** received B.Sc. degree in Electrical and Electronics Engineering from Gaziantep University, Turkey, in 2018. She is currently a M.Sc. student at Department of Electrical and Electronics Engineering at Gaziantep University. Her research interests include circuit design, embedded system, c

software.