

Analytical investigation of a new approach to calculation for effective length of the rolling element used in closed end needle roller bearings of driveshaft

Onur Şen^{1,2*}, Enver Atik²

¹Tirsan Kardan A.Ş., Manisa, Turkey

²Manisa Celal Bayar University, Mechanical Engineering Department, Manisa, Turkey

Orcid: O. Şen (0000-0001-8763-3246), E. Atik (0000-0001-8250-1957)

Abstract: The presence of oscillating motion in a mechanical system is highly critical in terms of its service life. The service life of the bearings which are one of the common machine elements is calculated according to international standard ISO 281 with the equation depending on several variables such as basic dynamic load rating (C). One of the applications where bearings are used is universal joints on the driveshafts. The bearings for universal joints (universal joint bearing) are special bearings called as closed end needle roller bearings. The rolling elements used in a universal joint bearing are the needle rollers. They have a larger contact surface when compared to the ball elements, and this makes a positive difference on the service life of the universal joint bearings. Needle roller on a universal joint bearing is supported partially along its length, unlike a needle roller used in basic applications such a round bar. Because the universal joint bearing is pressed into a housing bore on the yoke part, and the trunnions of the cross shaft which acts as an inner raceway is mounted into the bearing. In this context, the length of the needle roller supported by the trunnion of the cross shaft and housing bore, which is called effective length should be considered to compute the dynamic load rating. In this paper, an approach to determine the effective length of the rolling element used in the closed end needle roller bearing of a driveshaft has been investigated analytically. And then, the effects of the said approach on the basic dynamic load rating and bearing life have been revealed by considering ISO 281.

Keywords: Driveshaft, universal joint bearing, rolling element, needle roller, effective length, analytical investigation

1. Introduction

One of the most common mechanical systems is the rotating systems which consist of several elements such as bearing, housing, shaft, pulley etc. And bearings play an important role in this kind of machinery systems. Determining what kind of bearing to be used is the key for the service life of the whole system and the bearing life as well. The bearings can be considered in two subdivides as ball bearings and roller bearings. The roller bearings are categorized by their ability of motion and how they operate [1]. The motion of the bearings can be handled in three ways: rotary, linear, and combined motion. An oscillating motion which is a kind of rotary motion is the result of the cyclic movement of back and forth or start and stop. One of the areas where oscillating motion is common and critical is the drivetrain components of a motor vehicle. The drivetrain is a set of interrelated components such as transmission, driveshaft, and axles which

transmit the generated power to the driving wheels [2].

The universal joint which consists of two opposed yoke parts and an intermediate element (cross shaft assembly) among the yokes (Fig.1.) is a part of a driveshaft. The yokes are not parallel. But they intersect at a point. The angle among the yokes is called as operating angle. Another universal joint element, cross shaft assembly is an intermediate element located to provide a mechanical connection among the yokes which are at right angles to each other. The cross shaft assembly includes a cross shaft having four arms at the right angle to each other and four closed end needle roller bearings. Each arm of a cross shaft is supported by needle roller bearings mounted into a housing bore on the yoke part [3]. The needle roller is a kind of cylindrical roller having a smaller diameter when compared to their length [4]. Although there are five different rolling elements (balls, cylindrical rollers, spherical

* Corresponding author.
Email: o.sen@tirsankardan.com.tr



rollers, tapered rollers, and needle rollers), the needle rollers are used in the universal joint bearings. The main reason for using needle rollers is the cyclic loading due to the oscillating motion. Because needle roller bearings have a line contact which increases the rigidity and maximum load capacity of the universal joint while the ball bearings have a single point contact which limits the strength [5]. Additionally, the needle roller is the one suitable rolling element for the universal joints when considered that the internal space of the bearing is limited [6].

The universal joint on the driveshaft rotates in oscillatory motion. And it was proved by Poncelet in early years that the rotational movement of a universal joint on a driveshaft is non-uniform [7].

The difference of the angular displacement $\Delta\phi$ between the driving yoke and the driven yoke which results from the oscillatory motion for a universal joint with an operating angle β of 15° has been computed by means of both equations below, and then illustrated in Fig. 2.

$$\tan \varphi_2 = \frac{\tan \varphi_1}{\cos \beta} \quad (1)$$

$$\Delta\varphi = \varphi_1 - \varphi_2 \quad (2)$$

The angular displacement of the driven yoke is φ_2 when the angular displacement of the driving yoke is φ_1 in the equations.

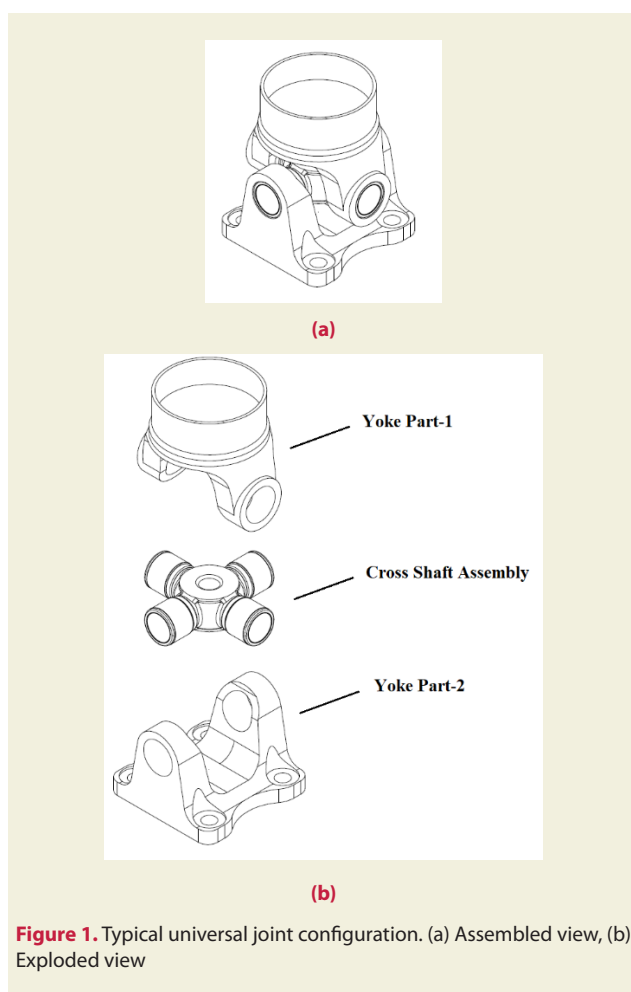

Figure 1. Typical universal joint configuration. (a) Assembled view, (b) Exploded view

The service life also known as useful life of a product is important for companies in terms of competition while it is important for end users in terms of the investment cost. Thus, a competitive manufacturer tends to improve the current service life. Therefore, the effect of the oscillating motion is vital for the service life of a universal joint bearing as well as universal joint and a driveshaft.

When the subjects of service life and optimization of bearings are reviewed in the literature, it is seen that the needle roller bearings and the ball bearings are mostly discussed and examined issues. In the literature review, it is observed that the needle roller and the cylindrical roller bearings are handled alone as an individual component without adjacent components such as a simple shaft in some papers.

Poplawski et al. (2001) investigated the effect of the roller profile on cylindrical roller bearing life prediction [8]. Basically, they took into consideration four different profiles for a rolling element: flat, tapered crown, aerospace crown and full crown profile. Different models of bearing life were chosen for this investigation: Weibull, Lundberg and Palmgren, Ioannides and Harris and Zaretsky. But in this study, only the bearing and the roller geometry were considered, not the housing bore where the bearing is mounted into.

Gupta et al. (2007) optimized the roller bearing by considering the basic static and dynamic load capacity [9]. In

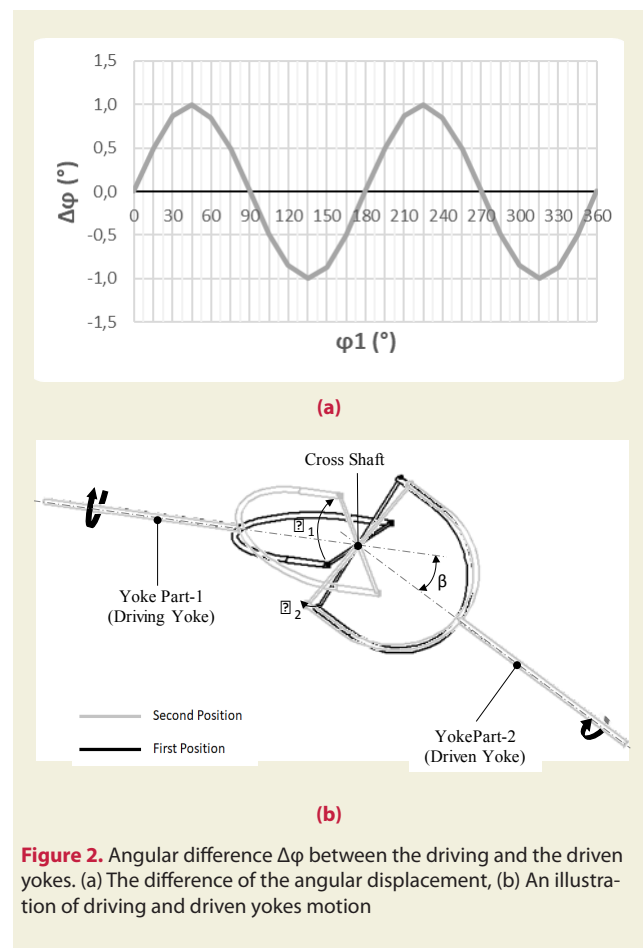

Figure 2. Angular difference $\Delta\varphi$ between the driving and the driven yokes. (a) The difference of the angular displacement, (b) An illustration of driving and driven yokes motion

this optimization, a kind of genetic algorithm was used. The ball bearing was considered in the study.

Kumar et al. (2008) presented an optimum design procedure depending on the geometric design variables for the cylindrical roller bearings [10]. The basic dynamic load capacity calculated to reach the bearing fatigue life. The effective length of the roller is one of the variables used in the equation of basic dynamic load capacity.

Shimizu et al. (2012) developed a new life theory for the rolling bearings [11]. In the study, the effective load length was used in the formulas based on Lundberg and Palmgren for an ideal stress distribution of load rating and so service life. The rollers examined in the paper are supported by an inner and outer ring.

Oswald et al. (2014) examined the effect of the roller geometry on the service life by considering different life estimation models [12]. The rollers of the bearing used in the study are supported along its length by an inner and outer ring. Thus, effective roller length is calculated by subtracting the value of crown radius from the total length of the roller, due to its fully supported length.

Waghole et al. (2014) have optimized the dynamic capacity of the needle roller bearing by using various algorithms and a hybrid method derived from them [13]. The roller diameter, roller length, pitch diameter and number of rollers have been considered in the study. The needle rollers in the bearing subjected to the study are supported by an inner and an outer ring. Thus, the effective roller length is calculated by subtracting the value of the corner radius from the total length of the roller.

Kalyan et al. (2015) have optimized the needle roller bearings considering the long fatigue life and the wear resistance. In this context, the dynamic capacity of the bearing has been examined in terms of seven variables including effective roller length since fatigue life is related to dynamic capacity [14].

Dragoni (2016) developed an optimization procedure for tapered roller bearings by considering maximum rating life [15]. The rollers are supported by inner and outer rings as in the cylindrical rolling elements. Therefore, the effective roller length for the calculation of the dynamic load capacity can be calculated by considering the total length only and chamfers of the roller.

Panda et al. (2018) presented an optimum design approach for the rolling element bearing in their study [16]. Optimum design approach considers the multi-objective constraints for deep groove ball bearings, weight, dynamic load capacity, and minimum elastohydrodynamic film thickness.

Dandagwhal et al. (2019) proposed an approach to optimum design for both cylindrical roller bearing and deep groove ball bearing [17]. In the calculation of dynamic ca-

capacity, the effective length of the roller was obtained by subtracting the chamfer dimensions at both ends from the total length of the rolling element. Because the rollers are supported by inner and outer rings of the bearing.

The rolling elements in the bearing structures which are subjected to the studies above are supported by inner and outer rings of the bearing. Additionally, the contact surface between the rolling elements and the supporting members has full contact along the bearing length due to the structure of the bearing which consists of rollers, inner ring, and outer ring. Thus, the effective roller length used to calculate dynamic load capacity and so service life, is calculated by subtracting the corner radius or the chamfer values from the total length of the roller. But this method is inadequate for the calculation of the effective roller length and the dynamic load rating of the closed end needle roller bearing mounted into a housing bore on a yoke part of a driveshaft. Because, the housing bore where the closed end needle roller bearing is mounted, does not have a continuing cylindrical form due to the angular yoke geometry (Fig. 3). In this paper, an approach to calculation of the effective length of a closed end needle roller bearing, has been presented through a case study, to fill the gap mentioned above.

2. Methodology

The methods for calculating the bearing life considering the oscillatory motion were presented by Houpert [18], Harris [19] and ISO 281:2007 standard [20]. Each approach depends on the basic dynamic load rating which

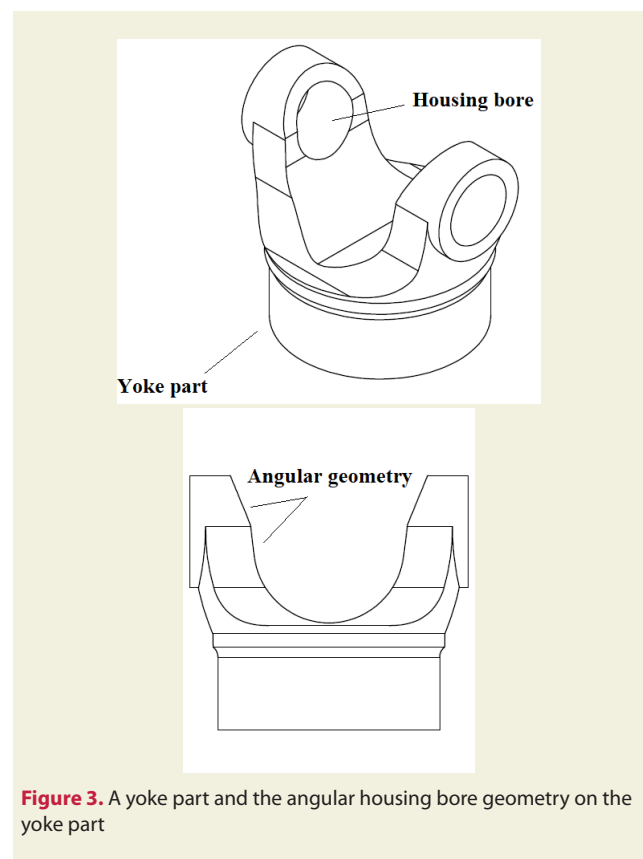

Figure 3. A yoke part and the angular housing bore geometry on the yoke part

is an expression of the load allowing 1 million revolutions before any fatigue failure is developed on the bearing elements. It is merely a radial load for the needle roller bearings. The dynamic load rating of the rolling bearings which affects the service life is defined in ISO 281:2007. The basic dynamic load rating and the basic rating life for the needle roller bearings can be calculated by the Eq. (3) and Eq. (4) below [20].

$$C_r = b_m f_c (i L_{we} \cos \alpha)^{7/9} z^{3/4} D_{we}^{29/27} \quad (3)$$

$$L_{10} = \left(\frac{C_r}{P_r} \right)^{10/3} \quad (4)$$

According to the Eq. (3), basic dynamic load rating for a radial load C_r depends on rating factor b_m (which varies with bearing type and design), bearing coefficient f_c , number of rows of rolling elements i , effective roller length L_{we} , nominal contact angle α (zero for needle roller bearings in driveshafts), number of rolling elements per row z and roller diameter D_{we} while L_{10} and P_r are respectively designated for basic rating life giving a 90 percent reliability, and equivalent radial load on the bearing in Eq. (4).

Table 1 and Table 2 are used to obtain the values of b_m and f_c in the radial roller bearings. Table 1 gives the value of b_m for the relevant bearing type such as drawn cup, cylindrical and spherical rollers. Table 2 gives the maximum value of f_c , as the value corresponding to $(D_{we} \cos \alpha)/D_{pw}$. Here, D_{pw} is pitch diameter of roller set which is calculated by Eq. (5). D_{we} and D_t are respectively the diameter of the rolling element and the trunnion diameter of the cross shaft.

$$D_{pw} = D_{we} + D_t \quad (5)$$

It is obvious that the dynamic load rating directly depends on the effective roller length L_{we} as it can be understood

Table 1. Values of b_m for radial roller bearings [20]

Bearing Type	b_m
Drawn cup needle roller bearings	1,00
Cylindrical roller bearings, tapered roller bearings and needle roller bearings with machined rings	1,10
Spherical roller bearings	1,15

Table 2. Maximum values of f_c for radial roller bearings [20]

$\frac{D_{we} \cos \alpha}{D_{pw}}$	f_c	$\frac{D_{we} \cos \alpha}{D_{pw}}$	f_c	$\frac{D_{we} \cos \alpha}{D_{pw}}$	f_c
0,01	52,1	0,11	85,4	0,21	88,5
0,02	60,8	0,12	86,4	0,22	88,2
0,03	66,5	0,13	87,1	0,23	87,9
0,04	70,7	0,14	87,7	0,24	87,5
0,05	74,1	0,15	88,2	0,25	87,0
0,06	76,9	0,16	88,5	0,26	86,4
0,07	79,2	0,17	88,7	0,27	85,8
0,08	81,2	0,18	88,8	0,28	85,2
0,09	82,8	0,19	88,8	0,29	84,5
0,10	84,2	0,20	88,7	0,30	83,8

from the Eq. (3).

The rolling elements in the closed end needle roller bearing are supported by the housing bore on the yoke part, and the trunnion of the cross shaft. Therefore, unlike the rolling elements in a bearing with an inner and an outer ring on a straight shaft, the rolling elements in the needle roller bearing used on a driveshaft are not supported along their lengths. In universal joints, taking the total length of the rolling element as the effective roller length misleads the calculation of the dynamic load rating. An approach which handles the effective roller length from a different viewpoint has been developed to fill this gap. The difference between the effective roller length obtained with the current calculation regardless of housing bore geometry and the effective roller length obtained with the said approach considering the housing bore geometry has been demonstrated and compared to each other in terms of the calculation of dynamic load rating for the closed end needle roller bearing.

2.1. Calculation of the dynamic load rating: regardless of the geometry of housing bore

Basically, the calculation below can be implemented to determine the effective length of the roller by only considering the closed end needle roller bearing. In this method, the housing bore which supports the closed end needle roller bearing is not considered. For the calculation, a closed end needle roller bearing has been sectioned along a plane passing through the center of the bearing (Fig. 4).

The effective roller length L_{we} is calculated by considering four parameters, respectively the length of the trunnion L_w and the radius r at the corner of rolling element, the number of the rows of rolling elements i and the thickness

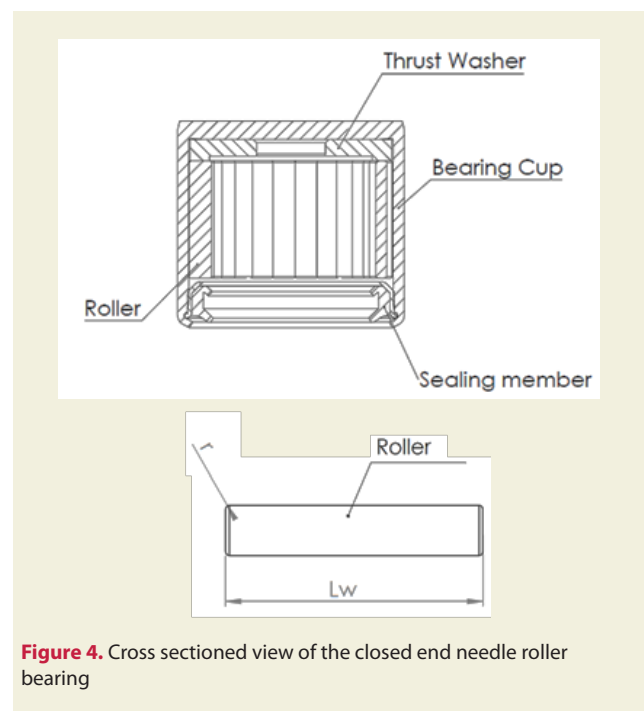

Figure 4. Cross sectioned view of the closed end needle roller bearing

of the washer t used between two rows, Eq. (6).

$$L_{we} = L_w - (2i)r - (i-1)t \tag{6}$$

2.2. New calculation of the dynamic load rating: depending on the housing bore geometry

The needle roller bearing is mounted into a housing bore on the yoke part of the driveshaft. The moment on the driveshaft results in a radial force on the yoke part, housing bore (Fig.5) and roller bearing (Fig.6).

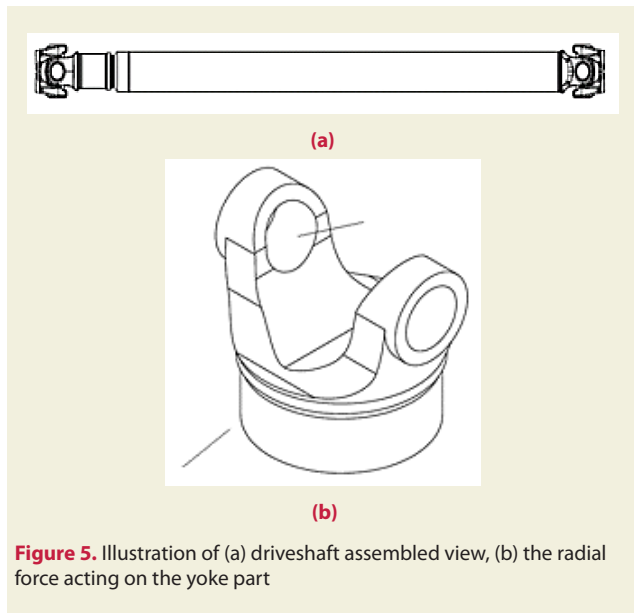

The housing bore and the closed end needle roller bearing have been investigated by sectioning along the plane which is through the center of the housing bore and parallel to the radial force (Fig. 6). The relationships among the sub-components of the closed end needle roller bearing, and between the closed end needle roller bearing and housing bore have been analyzed by means of the view of Detail H in Fig. 6.

The contact surfaces between the housing bore and the bearing have been revealed with a cross-section given by Detail-H in Fig. 6. The closed end needle roller bearing is supported by the housing bore. It is an important constructive point, and the key which should be considered for the calculation of the effective roller length L_{we} . Thus, intersection length L_i of projections of the trunnion and housing bore is one of the parameters to be used in the calculation of L_{we} in the approach.

Thrust washer have U-shaped cylindrical geometry. Its center is in contact with the trunnion end face while the protrusion of its U-shaped geometry is in contact with the rolling element's end face. Thus, the height of the trust washer h which is relative to the trunnion end should be considered as well for the calculation of the effective roller length L_{we} in the said approach.

In addition to the parameters h and L_i , the radius r at the corner of the rolling element is another parameter affecting the effective roller length because the radius shortens the roller length supported by the housing bore.

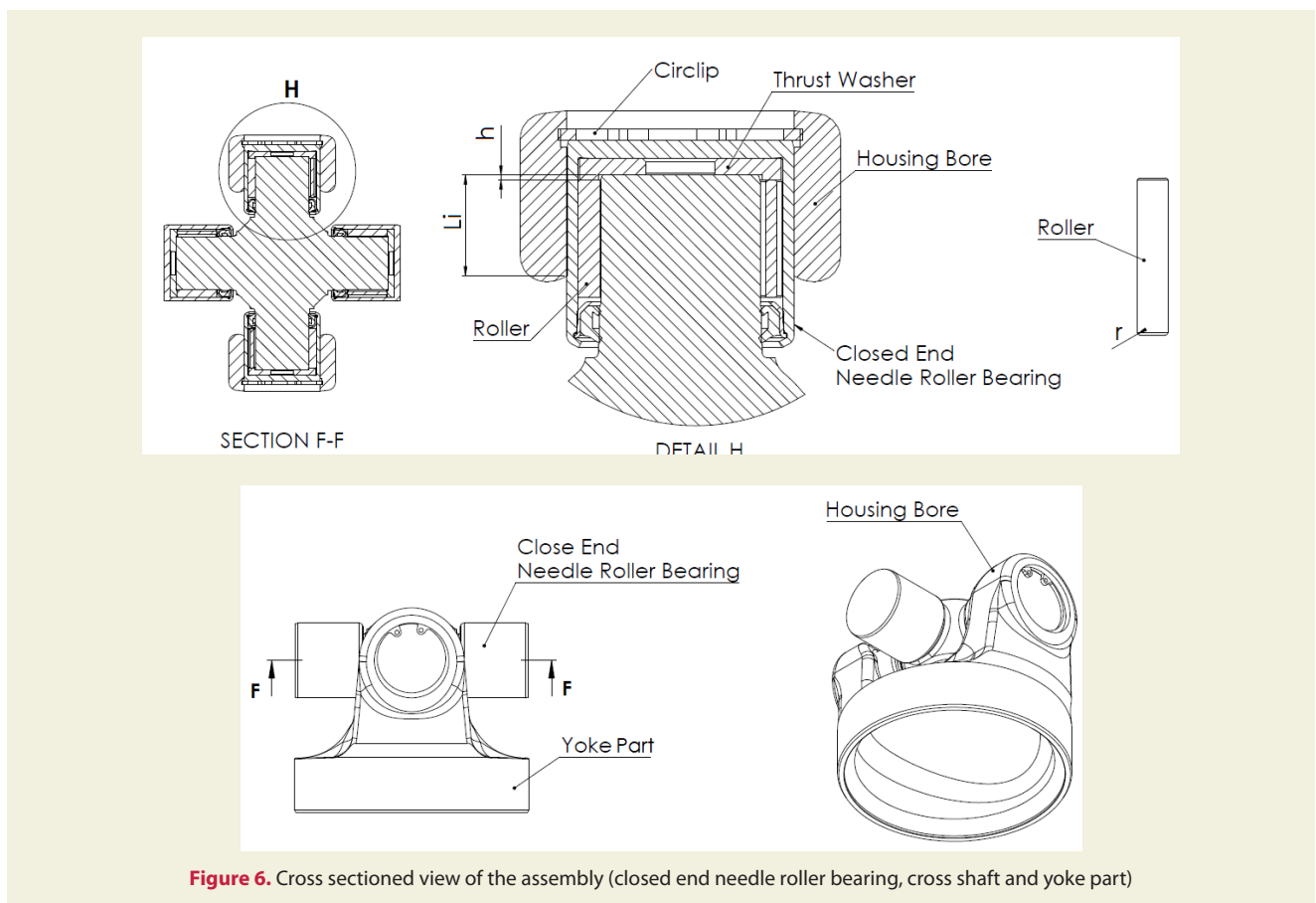

Figure 6. Cross sectioned view of the assembly (closed end needle roller bearing, cross shaft and yoke part)

Consequently, effective roller length L_{we} has been obtained by the Eq. (7):

$$L_{we} = L_i - h - (2i - 1)r - (i - 1)t \quad (7)$$

In the equation, the number of the rows for the rolling elements i has been included in the equation in case the needle roller bearing may consist of multiple rows. Depending on the usage of multiple rows, a washer may be used between two rows. In this situation, the thickness of the washer t has been included in the equation.

3. Results

In this section, dynamic load rating of the closed end needle roller bearing has been calculated as a case study, by using the presented approach and the existing calculation. Just after, the basic rating life has been calculated to reveal the effect of the presented approach on the estimated bearing life.

The data used in the calculations, which are based on the case study have been given in Fig. 7. The needle roller bearing includes 1 row and 25 rolling elements.

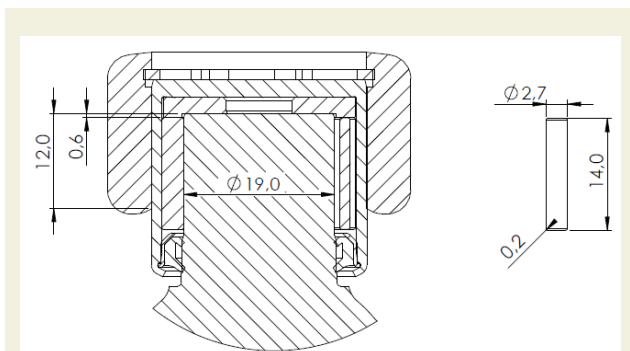

Figure 7. The data of assembly group and the needle roller

3.1. Results of the calculation regardless of geometry of the housing bore

This method in which the housing bore supporting the closed end needle roller bearing is not considered, uses Eq. (6) to calculate the effective roller length. The inputs required for Eq. (6), have been taken from Fig.7. And so, the effective roller length has been calculated as below.

$$L_{we} = L_w - (2i)r - (i - 1)t \quad (6)$$

$$L_{we} = 13,6 \text{ mm}$$

The basic dynamic load rating has been calculated by Eq. (3).

$$C_r = b_m f_c (i L_{we} \cos \alpha)^{7/9} Z^{3/4} D_{we}^{29/27} \quad (3)$$

b_m has been obtained as 1,00 for the drawn cup needle roller bearings on Table 1., and f_c has been obtained from Table 2. The other values have been taken from Fig.7. All values have been substituted in the Eq. (3). As a result, C_r is obtained as below.

$$C_r = 21,4 \text{ kN}$$

Basic rating life can be calculated in terms of millions of revolutions by using the Eq. (4) for the equivalent bearing load of 8 kN.

$$L_{10} = \left(\frac{C_r}{P_r} \right)^{10/3} \quad (4)$$

$$L_{10} = 26,8 \text{ M rev.}$$

3.2. Results of calculation according to the presented new approach

The new approach considering that the rolling elements of the closed end needle roller bearing are supported by both the housing bore and the trunnion of the cross shaft uses Eq. (6) to calculate effective roller length. The inputs required for the Eq. (6), have been taken from Fig.7. And so, the effective roller length has been calculated as below.

$$L_{we} = L_i - h - (2i - 1)r - (i - 1)t \quad (6)$$

$$L_{we} = 11,2 \text{ mm}$$

The basic dynamic load rating has been calculated by Eq. (3).

$$C_r = b_m f_c (i L_{we} \cos \alpha)^{7/9} Z^{3/4} D_{we}^{29/27} \quad (3)$$

b_m has been obtained as 1,00 for the drawn cup needle roller bearings on Table 1., and f_c has been obtained from Table 2. The other values have been taken from Fig.7. All values have been substituted in Eq. (3). Finally, C_r is obtained as below.

$$C_r = 18,4 \text{ kN}$$

Basic rating life can be calculated in terms of millions of revolutions, by using the Eq. (4) for the equivalent bearing load of 8 kN.

$$L_{10} = \left(\frac{C_r}{P_r} \right)^{10/3} \quad (4)$$

$$L_{10} = 16,2 \text{ M rev.}$$

4. Discussion

The effect of the presented approach on the dynamic load rating and, also the bearing rating life is shown in Fig. 8 by the comparison. If we consider both results respectively, it has been observed that:

1. The effective roller length which is required for the calculation of dynamic load rating according to ISO 281 varies depending on the calculation method. The new approach considering the housing of the yoke part of the driveshaft gives a more effective roller length compared to the current method.
2. The new approach gives the higher dynamic load rating which is calculated according to ISO 281.
3. It is obvious that the current method gives the lower service life which is calculated according to ISO 281 when compared with the new method.

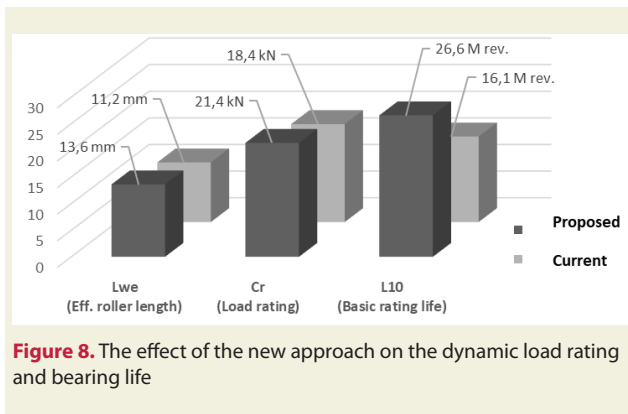

Figure 8. The effect of the new approach on the dynamic load rating and bearing life

5. Conclusions

In the driveshaft, the rolling elements of the closed end needle roller bearings are supported by the housing bore on the outside and cross shaft trunnion on the inside. The housing bore on the yoke part has an angular end because the yoke part of the driveshaft has an angular geometry. Therefore, unlike the rolling elements in the bearing with an inner and an outer ring, the rolling elements in the closed end needle roller bearing of driveshaft are not supported along their length. But the total length of the roller element is considered in the calculation of the effective roller length. In this context, a new approach handling the effective length of the rolling element from a different viewpoint has been developed to fill this gap.

The basic dynamic load rating has been calculated by using the formulation provided from ISO 281 to reveal the differences between both methods. Two different methods have been used in the calculation of the effective roller length and so the dynamic load rating. The new approach considers the housing bore geometry while the other ignores it.

The calculated dynamic load ratings by both methods, have been compared to each other. As a result of this study, it is obvious that the dynamic load rating obtained by the proposed approach is 14% lower than the other calculation method. Additionally, considering the feedbacks from the field, it is pointed out that the service life of the closed end needle roller bearing was higher than the estimated value by the current calculation. In this situation, considering the effective roller length as the total length of the roller in the universal joints misleads the calculation of the dynamic load rating. Therefore, the presented approach is suggested for the calculation of the dynamic load rating as well as service life of the closed end needle roller bearing used in the driveshaft.

6. References

- [1] Jat, A., Tiwari, R. (2020). Multi-objective optimization of spherical roller bearings based on fatigue and wear using evolutionary algorithm. *Journal of King Saud University-Engineering Sciences*, 32: 58-68.
- [2] Bauer, H., Cypra, A., Beer, A. (1993). *Automotive Hand-*
- [3] Heisler, H. (2002). *Advanced Vehicle Technology*, Butterworth, Heinemann, Oxford.
- [4] Shinde, D.S., Solanki, P.M., Chaudhari, J.R. (2013). Wear Analysis of U- Joint Needle Bearing. *International Journal of Science, Environment and Technology*, 2(2): 162-167.
- [5] Harris, P.M., Kotzalas, M.N. (2006). *Essential Concepts of Bearing Technology*, CRC Taylor & Francis, New York.
- [6] Lazovic, T., Marinkovic, A., Markovic, S. (2012). Mathematical Background of U-joint Repair. *IFAC Proceedings Volumes*, 45(2): 1249-1253.
- [7] Seher-Thoss, H.Chr., Schmelz, F., Aucktor, E. (2006). *Universal Joints and Driveshafts*, Springer-Verlag, Berlin.
- [8] Poplawski, J.V., Peters, S.M., Zaretsky, E.V. (2001). Effect of Roller Profile on Cylindrical Roller Bearing Life Prediction-Part II Comparison of Roller Profiles. *Tribology Transactions*, 44(3):417-427.
- [9] Gupta, S., Tiwari, R., Nair, S.B. (2007). Multi-Objective Design Optimization of Rolling Bearings Using Genetic Algorithms. *Mech. Mach. Theory*, 42(2):1418-1443.
- [10] Kumar, S.K., Tiwari, R., Reddy, R.S. (2008). Development of an Optimum Design Methodology of Cylindrical Roller Bearing Using Genetic Algorithm. *Int. J. Comput. Methods Eng. Sci Mech*, 9(6):321-41.
- [11] Shimizu, S., (2012). A New Life Theory for Rolling Bearings by Linkage between Rolling Contact Fatigue and Structural Fatigue. *Tribology Transactions*, 55:558-570.
- [12] Oswald, F.B., Zaretsky, E.V., Poplawski J.V. (2014). Effect of Roller Geometry on Roller Bearing Load-Life Relation. *Tribology Transactions*, 57(5):928-938.
- [13] Waghole, V., Tiwari, R. (2014). Optimization of Needle Roller Bearing Design Using Novel Hybrid Methods. *Mechanism and Machine Theory*, 72:71-85.
- [14] Kalyan, M., Tiwari, R. (2016). Multi-Objective Optimization of Needle Roller Bearings Based on Fatigue and Wear Using Evolutionary Algorithm. *Proceedings of the Institution of Mechanical Engineers, Part J: Journal of Engineering Tribology*, 230(2):170-185.
- [15] Dragoni, E., (2017). Optimal Design of Tapered Roller Bearings for Maximum Rating Life under Combined Loads. *Mechanics & Industry*, 18(1).
- [16] Panda, S., Panda, S.N. (2018). A Multi Objective Optimum Design Approach for Rolling Element Bearing. *Int. J. Interact Des. Manuf.*, 12:1095-1108.
- [17] Dandagwhal, R.D., Kalyankar, V.D. (2019). Design Optimization of Rolling Element Bearings Using Advanced Optimization Technique. *Arab J Sci Eng.*, 44:7407-7422.
- [18] Houpert, L. (1999). Bearing Life Calculation in Oscillatory Applications. *Tribology Transactions*, 42:136-143.
- [19] Harris, T.A., Rumbarger, J.H., Butterfield, C.P. (2009). *Wind Turbine Design Guideline: Yaw and Pitch Rolling Bearing Life*. Technical Report NREL/TP-500-42362. Colorado, USA.
- [20] International Organization for Standardization (2007). *Rolling Bearings—Dynamic Load Ratings and Rating Life*, ISO 281:2007.