

Analysis of Combustion and Cycle to Cycle Variations of an Ethanol (E100) Fueled Spark-Ignition Engine

Sachin Kumar Gupta¹ and K. A. Subramanian^{1*}

0000-0002-9651-9450, 0000-0003-2610-9680

¹Engines and Unconventional Fuels Laboratory, Department of Energy Science and Engineering, Indian Institute of Technology Delhi, New Delhi-110016, India

Abstract

Ethanol, produced from biomass, is a renewable fuel that can be an attractive alternative fuel to gasoline for the increasing concerns of energy security and the environment. In the present work, combustion characteristic of ethanol (E100) fueled spark-ignition engine is compared with base gasoline fuel, and consecutively evaluated the cycle-to-cycle variations (CCV) of the engine parameters. These investigations were performed on a 250cc air-cooled four-stroke single-cylinder port-fuel injection spark-ignition engine. The engine was operated at 3500 rpm and 4000 rpm of engine speed while maintaining the same loads for ethanol and gasoline. It was found from the results that the peak in-cylinder pressure (P_{peak}) is lower with ethanol than gasoline at a given load. The P_{peak} decreased from 27.5 to 25.5 bar when ethanol was used in the engine at 3500 rpm and 5 Nm load instead of gasoline. Moreover, the mass fraction burned of the air-fuel mixture was faster for ethanol as compared to gasoline. The CCV analysis showed that CCV of P_{peak} and location of P_{peak} ($\theta_{P_{peak}}$) were lowered for ethanol compared to gasoline. A decrement in the coefficient of variation (COV) of P_{peak} and $\theta_{P_{peak}}$ from 11.6% to 8.3% and 12.6% to 11.7%, respectively, were observed when ethanol was utilized in the engine instead of gasoline at 3500 rpm and 5 Nm load. This resulted in a decrease in the COV of IMEP and engine speed by 2.8% and 0.25%, respectively, for ethanol as compared to gasoline. This study indicates that the combustion stability is better for ethanol-fueled spark ignition engine as compared with gasoline fuel.

Keywords: Combustion analysis, Cycle to cycle variations, Port fuel injection, Spark-Ignition Engine, Ethanol, Gasoline.

Research Article

<https://doi.org/10.30939/ijastech..999559>

Received 23.09.2022
Revised 18.01.2022
Accepted 29.01.2022

* Corresponding author

K. A. Subramanian
subra@ese.iitd.ac.in

Address: Department of Energy Science and Engineering, Indian Institute of Technology Delhi, 110016, India

1. Introduction

Over the past few years, the consumption of fossil fuels has been significantly increased due to an improvement in the standard of livelihood. However, the source of fossil fuel such as gasoline is limited and over-utilization of fossil-fueled internal combustion engines resulted in the depletion of fossil fuel at a faster rate, which is increasing the concerns of energy security and the environment. Thus, alternative fuels such as ethanol can be a feasible alternative to fossil fuels. Ethanol is a renewable fuel as it can also have obtained from organic matter such as crop residue, agriculture waste, and wood residue using thermochemical methods. The utilization of ethanol (produced from biomass) in spark-ignition (SI) engines can be considered carbon neutral. Thus, various countries' governments have initiated to add an amount of ethanol in gasoline and put their effort to increase its proportion.

Utilizing ethanol in an SI engine improves the performance and reduces emissions since ethanol has better anti-knocking characteristics as compared to gasoline as shown in Table 1. It allows the engine to increase the compression ratio, which further improves the engine efficiency. Latent heat of vaporization of ethanol (i.e., 840 kJ/kg) is significantly higher than gasoline (i.e., 350 kJ/kg); see Table 1. Using ethanol as fuel decreases the charge density and improves the engine's volumetric efficiency as compared to gasoline [5]. But, the lower heating value of ethanol is lower with respect to gasoline (see Table 1), which leads to higher fuel consumption. Due to the abovementioned difference in the properties of ethanol and gasoline, it is essential to investigate ethanol's influence in a gasoline-fueled spark-ignition engine. In addition, the change in physical and chemical properties of ethanol as compared to gasoline affects the cycle-to-cycle variations (CCV) of engine parameters, which results in fluctuations in torque and speed, and

thus vibrations. The CCV is also affected by inconsistencies in mixture preparation from one cycle to the next, randomness in mixture motion in the vicinity of the spark plug at the time of ignition, and spark scattering [1, 6]. The statistical variation of any parameter (say A) can be measured in terms of the coefficient of variation (COV) of A. Eq. 1 can be used to calculate the COV of A [7].

$$COV \text{ of } A = \frac{\text{standard deviation of } A}{\text{mean of } A} \times 100 \quad (1)$$

Table 1. Comparison of properties of gasoline and ethanol

	Ethanol	Gasoline
Chemical formula	CH ₃ CH ₂ OH	C _n H _{1.87n}
Lower heating value, LHV (MJ/kg) [1]	26.9	44
Stoichiometry air-fuel mixture ($\phi = 1$)	9	14.5
LHV of $\phi = 1$ (MJ/kg)	2.69	2.83
Research octane number	107 [1]	91
Molecular weight	46.07	~110
Latent heat of vaporization* (kJ/kg)	840	350
Adiabatic flame temperature (K)	2238 [2]	~2470 [3]
Auto-ignition temperature (K)		~500–750 [3]
Laminar flame speed at $\phi = 1$ * (m/s)	0.5 [4]	0.37–0.43 [3]

*1 atm and 25 °C

Previous work on comparing CCV of ethanol and gasoline has been discussed. Ceviz and Yüksel [8] studied CCV of the engine fueled with a different blend of ethanol and gasoline. The ethanol proportion was varied from 0 to 20% in the blend of gasoline and ethanol at wide-open throttle and 2000 rpm of the engine without maintaining a constant equivalence ratio. They observed a decrement in the COV of indicated mean effective pressure (IMEP) till 10% of ethanol in the blend and the further started increasing. Wang et al. [9] performed experiments on the engine using a blend of 20% (by volume) hydrous ethanol and gasoline to study CCV. They varied the load from 10 to 50 Nm while operating at different speeds (i.e., 1200, 1600, and 2000 rpm). Chen et al. [10] operated the engine on various fuels including ethanol and compared the engine characteristics along with cycle-to-cycle variations. They found that the peak cylinder pressure for ethanol fuel is higher than n-butanol and lower than methanol fuel while operating the engine at a stoichiometric air-fuel ratio and 1600 rpm. The COV of IMEP was higher for the engine operated with n-butanol as compared to methanol and ethanol fuels. Musaab et al. [11], performed experiments on the engine using hydrous ethanol and 10% (by volume) blend with gasoline (i.e., E10). The brake torque was higher was slightly higher for E10 as compared to gasoline, whereas NO emission decreased for E10. Ilhak et al. [12] investigated the engine characteristics for various fuels such as acetylene, gasoline, and

ethanol at partial loads. They showed that the brake thermal efficiency was higher for ethanol as compared to gasoline, whereas unburned hydrocarbon and nitric oxide emissions decreased for ethanol. Shetty and Rao [13] prepared blends of ethanol with gasoline by varying ethanol from 0 to 20% and utilized it in the engine while maintaining fixed spark timing. They found that the peak pressure increased and COV of IMEP decreased with an increase in the percentage of ethanol in the blend. Yanin et al. [14] mixed 20% hydrous ethanol and 20% anhydrous ethanol by volume with gasoline to study cycle-to-cycle variations of the engine. They found that the cycle-to-cycle variations were lowest for the blend of 20% anhydrous ethanol and gasoline at low speed and loads. Moreover, at higher load and speed, the combustion became more stable for the blend of 20% hydrous ethanol and gasoline. The authors observed that CCV of combustion is higher for gasoline as compared to the blend at 1600 and 2000 rpm. A very limited study has been done on understanding the CCV of the engine fuel with ethanol (E100) and its comparison with baseline gasoline. Thus, in the present work, a single-cylinder four-stroke air-cooled port-fuel injection spark-ignition engine is utilized to investigate the effect of ethanol on the combustion characteristics and CCV of the engine and compared with the gasoline-fueled engine.

2. Experimental Set-up

For this investigation, a single-cylinder four-stroke port-fuel injection spark-ignition engine was utilized. The engine specification is provided in Table 2. The layout of the experimental set-up is shown in Fig. 1, schematically. To vary the load on the engine, a water-cooled eddy current dynamometer was utilized. The flow rate of air and fuel to the engine were measured by an orifice-type flowmeter and Coriolis-based flowmeter (RHEONIK make), respectively. A piezoelectric transducer (AVL make) was instrumented in the cylinder head to measure in-cylinder pressure. A combustion analyzer (AVL make) was utilized to monitor combustion parameters in real-time and record the combustion parameter. A lambda sensor was installed in the exhaust port to measure the air-fuel ratio. An electronic control unit (ECU) was utilized to control the injector and instance of spark according to engine speed and throttle opening. For investigating CCV of various parameters, the cylinder pressure traces of 100 consecutive cycles were recorded [15]. The uncertainty associated with the piezoelectric transducer is $\pm 0.8\%$ while measuring the in-cylinder pressure.

Table 2. Specification of the spark-ignition engine

Bore (mm)	74
Stroke (mm)	58
Connecting rod length (mm)	112
Rated power (kW)	15 (at 8000 rpm)
Rated torque (Nm)	18 (at 6000 rpm)
Compression ratio	9.8:1

In India, fuel available at the petrol pumps for spark-ignition engine is a blend of gasoline and ethanol. Ethanol needs to be removed from the fuel to perform baseline of the engine using pure

gasoline. Ethanol can be removed from the fuel with the help of water in cone-shaped flask with valve at the bottom since ethanol dissolves better in water than gasoline. For the investigation, firstly, the engine fueled with ethanol (E100) was operated at maximum

operating load while maintaining 4000 rpm and 3500 rpm and the combustion characteristics were compared with gasoline at same load. The comparative study was done at stoichiometric air-fuel

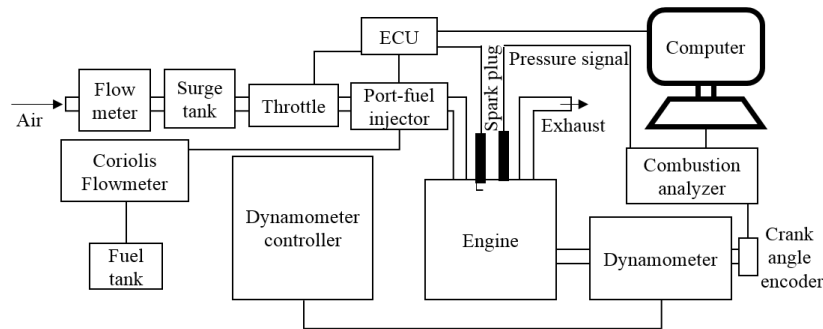

Fig. 1. Illustration of the engine test bench

ratio of the fuels. Further, CCV of various parameters were evaluated for ethanol and compared with gasoline for maximum load at 3500 rpm. The data was recorded when the engine was operated under steady-state conditions.

3. Results and discussion

3.1 Combustion analysis

Combustion analysis provides a better insight into in-cylinder phenomena. Fig. 2 shows the comparison of the averaged value of 100 cycles in-cylinder pressure of ethanol- and gasoline-fueled engine operated at 4000 rpm and 7 Nm load. It is to be observed that for the same operating load the peak in-cylinder pressure (P_{peak}) was lower for ethanol as compared to gasoline. It is due to the lower adiabatic flame temperature of ethanol (2238 K [2]) compared to gasoline (2470 K [3]). The P_{peak} was decreased from 31 bar to 26 bar when ethanol was introduced in the engine instead of gasoline at 4000 rpm and 7 Nm load. A similar trend was also observed while comparing averaged in-cylinder pressure traces of ethanol- and gasoline-fueled engine operated at 3500 rpm and 5 Nm load, as shown in Fig. 3. The P_{peak} was decreased from 27.5 bar to 25.2 bar when ethanol was used in the engine instead of gasoline at 3500 rpm and 5 Nm load. Fig. 2 and 3 also show the rate of pressure rise for gasoline and ethanol while operating the engine at 4000 and 3500 rpm, respectively.

The net-pressure method was utilized to determine mass fraction burned (MFB) using in-cylinder pressure [16]. In the present work, combustion duration was considered the crank angle degree (CAD) from 10% to 90% MFB. Fig. 4 shows the variation of MFB and heat release rate (HRR) of the engine operated with ethanol and gasoline at 4000 rpm and 7 Nm load. It was observed that the combustion duration for ethanol and gasoline were 38 and 40 CAD, respectively. Since the flame speed of ethanol is higher compared to gasoline, see Table 1. In addition, Fig. 5 shows the variation of MFB and HRR of the engine operated with ethanol and gasoline at 3500 rpm and 5 Nm load. The combustion duration was 37 CAD and 39 CAD for ethanol and gasoline, respectively.

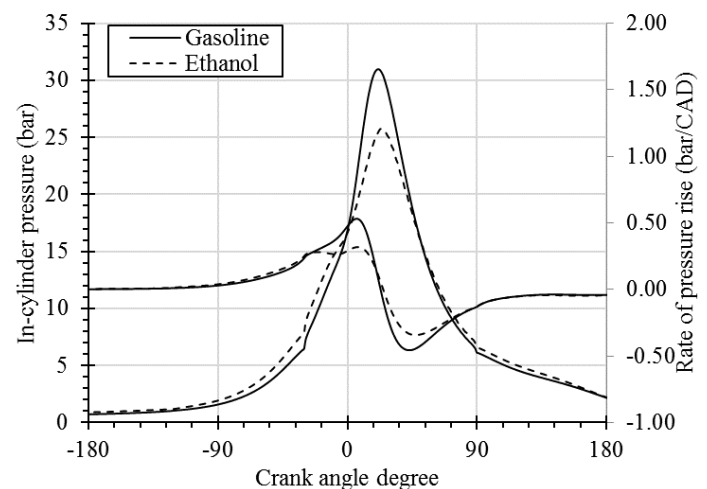

Fig. 2. In-cylinder pressure trace of ethanol compared with gasoline-fueled engine at 4000 rpm and 7 Nm

Fig. 6 shows the variation of in-cylinder pressure trace from one cycle to another using 100 cycles data of the engine fueled with gasoline at 3500 rpm and 5 Nm load. These variations depend on various reasons such as properties of the fuel, variation in the amount of intake air, randomness in air-fuel mixture near spark-plug, and spark scattering. This CCV of in-cylinder pressure resulted in the variation of instantaneous speed of the engine from one cycle to another. Fig. 7 shows the CCV of instantaneous engine speed for ethanol and gasoline while operating the engine at 3500 rpm and 5 Nm. The CCV of engine speed is lower for ethanol as compared to gasoline and observed that COV of engine speed was 0.06% for ethanol and 0.32% for gasoline.

Fig. 8 shows CCV of P_{peak} for ethanol- and gasoline-fueled engines operated at 3500 rpm and 5 Nm. The CCV of P_{peak} was reduced for ethanol fuel as compared to gasoline- as a reduction from 11.6% to 8.3% was observed. This decrement in the CCV of P_{peak} is due to the better flame speed of ethanol, see Table 1. However, the peak in-cylinder pressure of the combustion chamber lowered for ethanol compared to gasoline which is due to the

lower adiabatic flame temperature of ethanol, see Table 1. Additionally, higher latent heat of vaporization of ethanol as compared to gasoline reduces the charge temperature and subsequently decreased the cylinder pressure.

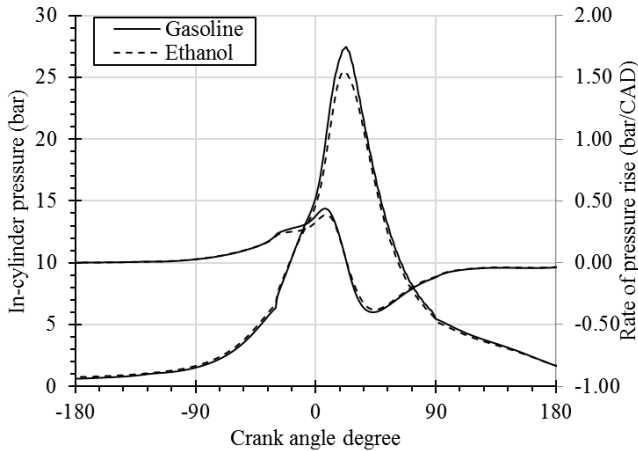

Fig. 3. In-cylinder pressure trace of ethanol compared with gasoline-fueled engine at 3500 rpm and 5 Nm

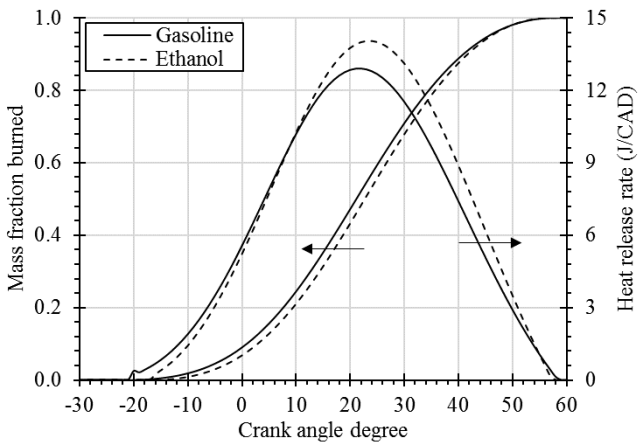

Fig. 4. Mass fraction burned for ethanol and gasoline-fueled engine at 4000 rpm and 7 Nm

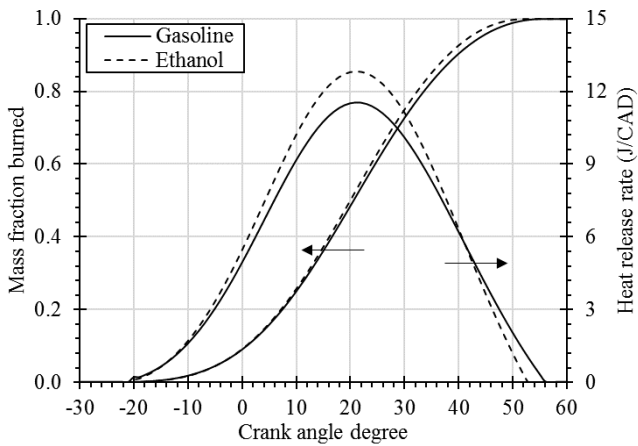

Fig. 5. Mass fraction burned for ethanol and gasoline-fueled engine at 3500 rpm and 5 Nm

3.2 Cycle-to-cycle variations (CCV) of engine parameters

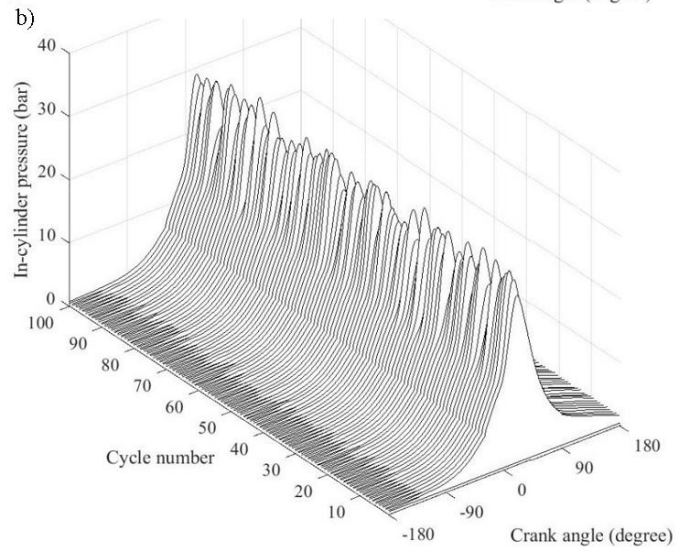
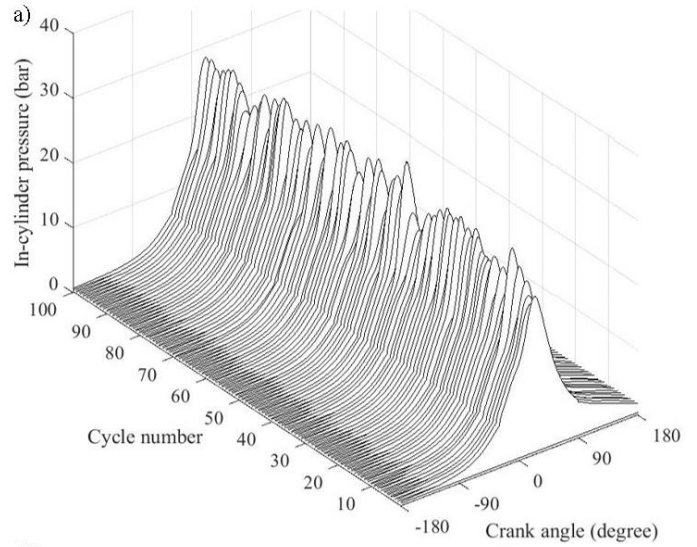

Fig. 6. CCV of in-cylinder pressure traces for the engine fueled with a) gasoline and b) ethanol at 3500 rpm and 5 Nm

Fig. 9 shows the CCV of the location of P_{peak} ($\theta_{P_{peak}}$) for ethanol- and gasoline fueled engine operated at 3500 rpm and 5 Nm. The $\theta_{P_{peak}}$ is a strong parameter that represents the flame speed in the combustion chamber [1]. The CCV of $\theta_{P_{peak}}$ reduced for ethanol as compared to gasoline which clearly shows that the variation in the flame speed is lower for ethanol. The COV of $\theta_{P_{peak}}$ decreased from 12.6 to 11.7% when ethanol was introduced in a gasoline-fueled engine.

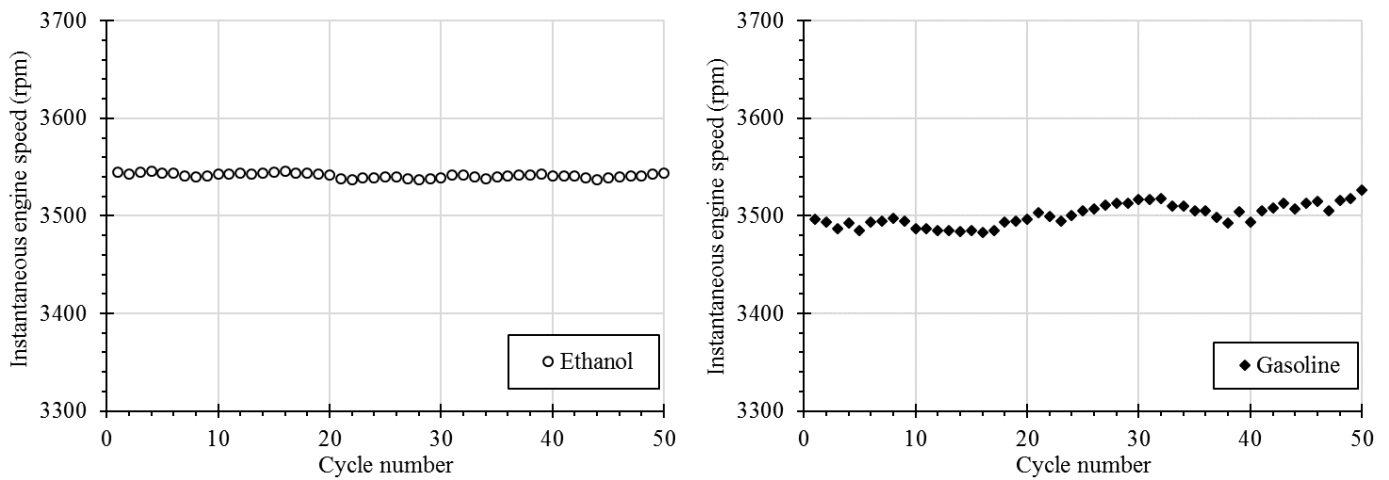

Fig. 7. CCV of engine speed for ethanol and gasoline at 3500 rpm and 5 Nm

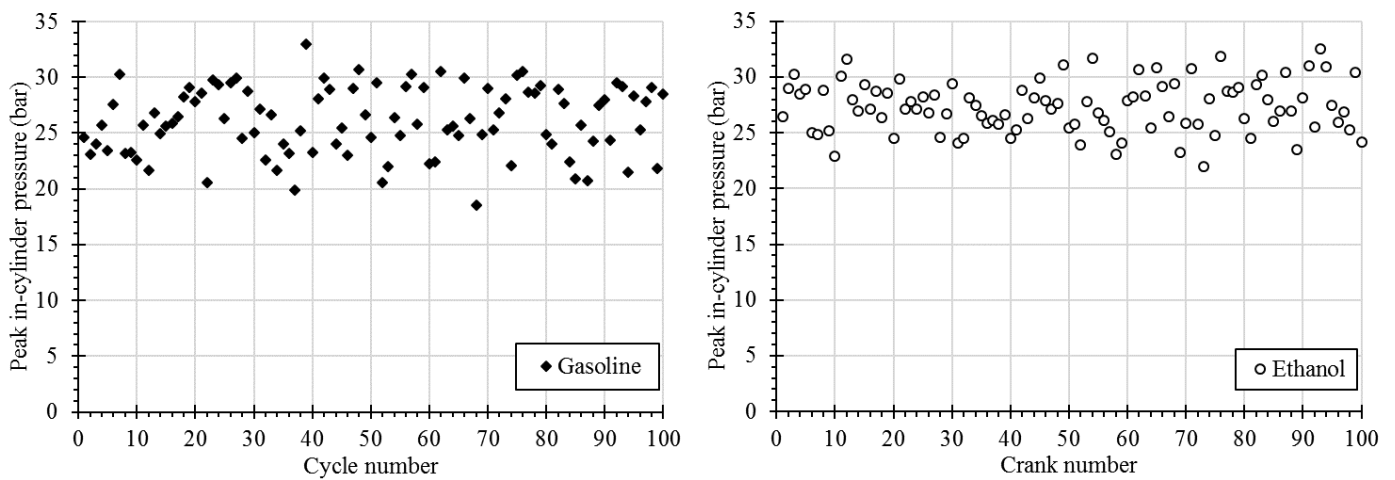

Fig. 8. CCV of peak in-cylinder pressure for ethanol and gasoline fueled engine at 3500 rpm and 5 Nm

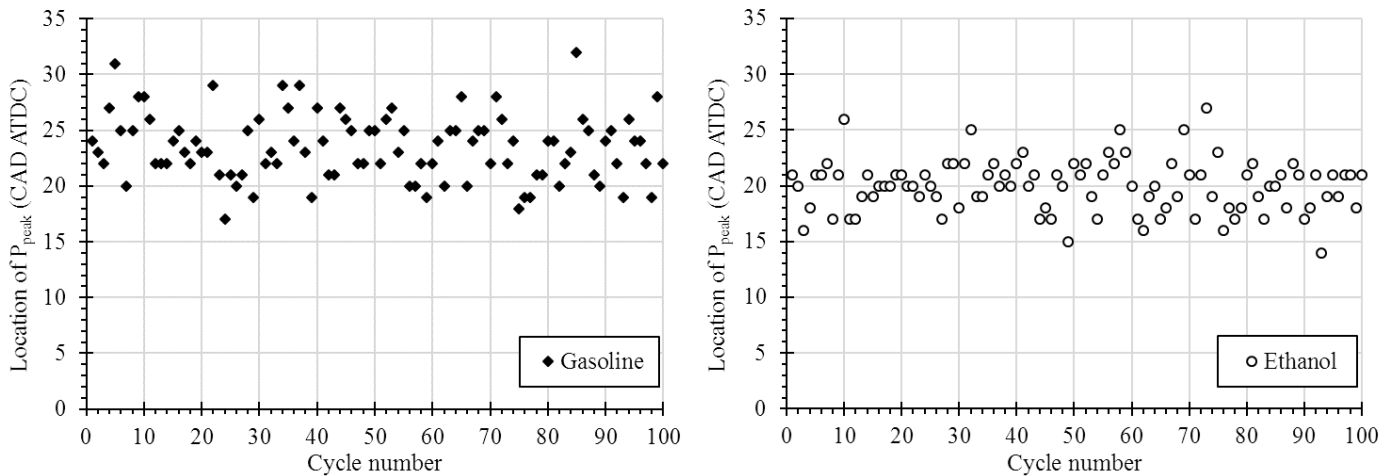

Fig. 9. CCV of the location of P_{peak} for ethanol and gasoline fueled engine at 3500 rpm and 5 Nm

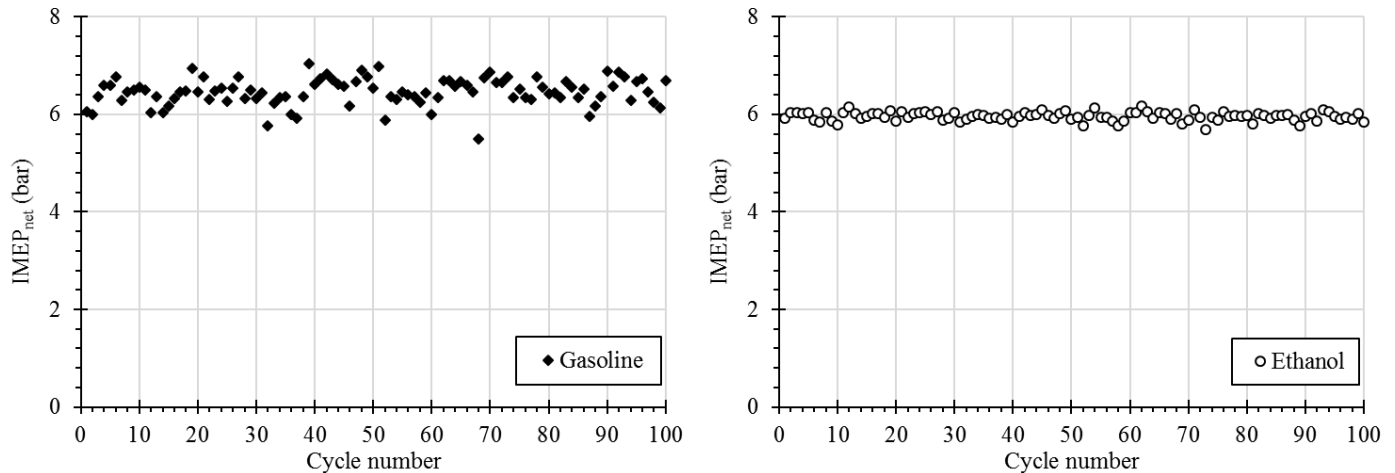

Fig. 10. CCV of IMEP for ethanol and gasoline fueled engine at 3500 rpm and 5 Nm

Fig. 10 shows the CCV of IMEP for ethanol, and gasoline fueled engine operated at 3500 rpm and 5 Nm. The CCV of IMEP decreased for ethanol compared with respect to gasoline, this can be attributed to improvement in the flame speed of ethanol. This resulted in a decrement of negative work on the piston by in-cylinder charge before the top dead center. The COV of IMEP decreased from 4.3% to 1.5% when ethanol was introduced in the engine instead of gasoline.

3. Conclusions

The combustion characteristics of a spark-ignition engine fueled with ethanol (E100) are compared with base gasoline. The following conclusions are drawn based on the study results:

- Mass fraction burnt with ethanol is shorter than base gasoline due to its high flame velocity.
- The combustion duration is lower with ethanol than gasoline. The combustion duration with 10% to 90% burnt is 37 CAD and 39 CAD with ethanol and gasoline, respectively.
- The cycle-to-cycle variations of the peak cylinder pressure (P_{peak}) is higher with gasoline. The COV of P_{peak} was 11.6% and 8.3% for gasoline and ethanol while operating the engine at 3500 rpm and 5 Nm load, respectively.
- The combustion stability of the spark ignition engine is better with ethanol (E100) than that of base gasoline as COV of IMEP is significantly lower for ethanol (1.5%) as compared to gasoline (4.3%).

Acknowledgment

This study was carried out on the facility developed with the fund support of the Department of Science and Technology (DST) for the BRICS project.

Conflict of Interest Statement

The authors declare that there is no conflict of interest in the study.

CRedit Author Statement

Sachin Kumar Gupta: Conceptualization, Writing-original draft, Data curation and Formal analysis.

K. A. Subramanian: Conceptualization and Supervision.

References

- [1] Phuangwongtrakul S, Wechsator W, Sethaput T, Suktanga K, Wongwisesa S. Experimental study on sparking ignition engine performance for optimal mixing ratio of ethanol–gasoline blended fuels. *Applied Thermal Engineering*. 2016; 100: 869-879
- [2] Heywood JB, *Internal Combustion Engine Fundamentals*, New Delhi: Tata McGraw-Hill, 2012.
- [3] Gupta SK, Mittal M. Effect of Compression Ratio on the Performance and Emission Characteristics, and Cycle-to-Cycle Combustion Variations of a Spark-Ignition Engine Fueled with Bio-Methane Surrogate. *Applied Thermal Engineering*, 2019; 148 :1440-1453.
- [4] Glaude PA, Fournet R, Bounaceur R, Molière M. Adiabatic flame temperature from biofuels and fossil fuels and derived effect on NOx emissions. *Fuel Processing Technology*. 2010; 91(2): 229-235.
- [5] Del Pecchia M, Pessina V, Berni F, d'Adamo A, Fontanesi S. Gasoline-ethanol blend formulation to mimic laminar flame speed and auto-ignition quality in automotive engines. *Fuel*. 2020; 264: 116741.
- [6] Gupta SK, Mittal M. Analysis of Cycle-To-Cycle Combustion Variations in a Spark-Ignition Engine Operating under Various Biogas Compositions. *Energy & Fuels*, 2019; 33(12): 12421–12430.
- [7] Gupta SK, Mittal M. Assessing the Influence of Compression Ratio On Engine Characteristics Including Operational Limits of a Biogas-Fueled Spark-Ignition Engine, *J. Eng. Gas Turbines Power*, 2020; 142(12): 121008.
- [8] Ceviz MA, Yüksel F, Effects of ethanol–unleaded gasoline blends on cyclic variability and emissions in an SI engine, *Appl Therm Eng*, 2005; 25(5-6): 917-925.
- [9] Wang Y, Luo M, El-Faroug M. The influence of hydrous ethanol gasoline on cycle-to-cycle variation of a spark ignition engine. *Thermal Science*, 2018; 22(3): 1373-1384.

- [10] Chen Z, Wang L, Zeng K. Comparative study of combustion process and cycle-by-cycle variations of spark-ignition engine fueled with pure methanol, ethanol, and n-butanol at various air–fuel ratios, *Fuel*, 2019; 254: 15683.
- [11] El-Faroug MO, Yan F, Luo M., Turkson RF. Spark Ignition Engine Combustion, Performance and Emission Products from Hydrous Ethanol and Its Blends with Gasoline, *Energies*, 2016; 9(12), 984.
- [12] İlhak M, Doğan R, Akansu SO, Kahraman N. Experimental study on an SI engine fueled by gasoline, ethanol and acetylene at partial loads, *Fuel*, 2020; 261(1), 116148.
- [13] Shetty S, Rao SB. In-cylinder pressure based combustion analysis of cycle-by-cycle variations in a dual spark plug SI engine using ethanol-gasoline blends as a fuel, *Materialtoday:Proceedings*, 2021.
- [14] Wany Y, Luo M, El-Faroug M. The influence of hydrous ethanol gasoline on cycle-to-cycle variation of a spark ignition engine, *Thermal Science*, 2018, 22(3): 1373-1384.
- [15] Gupta SK, Mittal M. Effect of Biogas Composition Variations on Engine Characteristics Including Operational Limits of a Spark-Ignition Engine, *ASME Journal of Engineering for Gas Turbines and Power*, 2019, 141(10): 101002.
- [16] M. Mittal M, G. Zhu G, Schock H. Fast mass-fraction-burned calculation using the net pressure method for real-time applications. *Proceedings of the Institution of Mechanical Engineers, Part D: Journal of Automobile Engineering*. 2009; 223(3): 389-394.