

This paper was recommended for publication in revised form by Regional Editor Dongsheng Wen

DESIGN CONSIDERATIONS OF CONFORMAL COOLING CHANNELS IN INJECTION MOULDING TOOLS DESIGN: AN OVERVIEW

*** Eric Dimla**

Mechanical Engineering Programme Area, Faculty of Engineering, Institut Teknologi Brunei,
Jalan Tungku Link, Gadong BE1410, Bandar Seri Begawan, Brunei Darussalam

Keywords: Thermoplastic, cooling channels, conformal cooling, injection moulding, temperature distribution, cycle time

** Corresponding author: Eric Dimla
E-mail address: dimla@itb.edu.bn*

ABSTRACT

Design of the cooling system in the thermoplastic injection moulding process is one of the most important steps during mould design. It has a direct influence on the quality of the parts produced, and thereby impinges on the cycle time. Cooling channel design has traditionally been limited to comparatively simple configurations due to the main process for manufacturing being restricted to the drilling of straight holes. Nowadays, with the emergence and rapid uptake of 3D printing, complex shapes are able to be produced with intricate details and more complicated geometries.

The objective of this study was to determine the temperature profile along the mould tool cavity wall to improve the cooling system design. Virtual models from a 3D modelling software (such as Solidworks and Moldflow) are used to design a simple artefact and simulate studies to include different cooling systems such as straight and conformal channels. The effects of cooling channel form and location on the temperature distribution of the mould and the solidification degree of polymer are studied. The bulk of the results indicate that in order to improve the productivity of the process, the cooling and cycle times have to be minimised while at the same time a homogeneous cooling is necessary to maintain a consistent quality of product.

1. BACKGROUND

Nowadays, plastic materials abound most products mainly due to their properties and ease of manufacture. Used in the transport industries to save weight and energy, plastic productions have grown substantially in recent decades. Most plastic parts are produced by amongst others, the injection

moulding process, reputed as being economical with a high production rate, high repeatability and the possibility to manufacture a large variety of complex parts. The Injection moulding process can basically be viewed as a four stepped process: closing of the mould, filling of the mould cavity, cooling, and ejection of the part. The cycle time has to be evaluated and adjusted to be as short as possible in order to increase production rates and thus make the process economic.

The variable "time", is the main determinant of the cost efficiency of any manufacturing process. The longest time throughout this process is taken up during the cooling phase; representing an average of 60% of the cycle time. It is therefore crucial to understand the heat transfer within a mould to be able to manage this variable. Since the polymer melt is injected at temperatures in the region of 200°C it is imperative that this heat is removed as quickly as possible while still allowing the polymer to totally fill the cavity. To this effect, cooling channels carrying a cooling medium are manufactured into the cores and cavities of the mould to help in the removal of this heat. The position, shape and size of the cooling channels play a major role in the overall cooling time of the part and resulting in the homogeneous structure of the molten material thereby minimising warpage from any inconsistency (Crawford, 1998).

Historically cooling channels have been formed by drilling straight holes around the core and cavity. To link the holes together to form a continuous cooling circuit, additional holes are drilled and plugged (Figure 1A). This can be difficult and it is not always possible to match the shape of the part. When the part has considerable depth it is necessary to build baffles or bubblebers into the core, which are not always successful and do

not necessarily conform to the shape of the part (Ring et al., 2002).

Additive or Layer Manufacturing methods commonly referred to as Rapid Prototyping (RP) enable complex shapes to be produced thus providing the potential to manufacture tools

with complex cooling circuits which conform to the shape of the tool. There are a number of potential RP routes, for the purpose of this project a process known as Selective Laser Sintering (SLS)

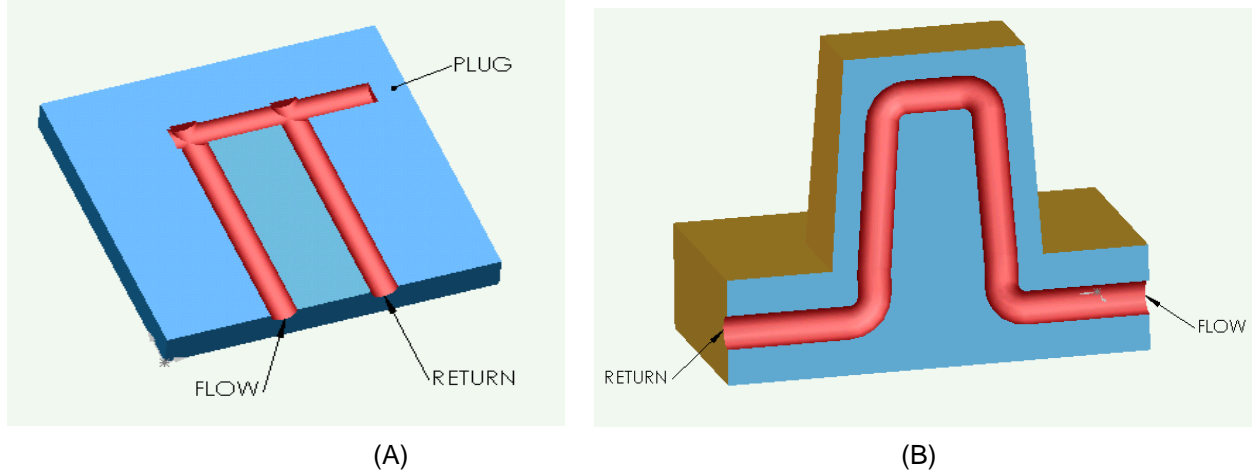

FIGURE 1: FORMAL (A) AND CONFORMAL (B) COOLING CHANNELS (RING ET AL., 2002)

(SLS) is best suited as the part can be built in layers and thus produce not only the required outer shape but also cooling channels, which conform to the shape of the part, (Figure 1B). Conformal channels or geometries allow better diffusion of the heat from the molten polymer and thereby offer better controlled temperature distribution within the mould cavity.

RP processes are a group of technologies that have revolutionized product development and manufacturing. These processes are capable of producing complex geometric components directly from three-dimensional computer generated models by building parts layer by layer with each layer containing the cross-section of the CAD file data. The applications of RP have been shown to greatly reduce the design to manufacturing cycle, resulting in reduced cost and increased competitiveness (Chua et al., 2010).

In the SLS build process (Figure 2); a roller (B) spreads the thermoplastic powder (A) over the surface of a build cylinder (C). The piston in the cylinder (D) moves down one object layer thickness to accommodate the new layer of powder. The powder delivery system (E) is similar in function to the build cylinder. Here, a piston moves upward incrementally to supply a measured quantity of powder for each layer. The CO₂ laser beam then traces over the surface of the tightly compacted powder to melt and bond it to form a layer of the object. The fabrication chamber is maintained at a temperature just below the melting point of the powder so that heat from the laser need only elevate the temperature slightly to cause sintering, speeding up the process. The process is repeated until the entire object is fabricated. After the object is fully formed, the piston is raised to elevate it. Excess powder is simply brushed away and any final manual finishing may be carried out. No supports are required with this method since overhangs and undercuts are supported by the solid powder bed.

This paper reports the current state-of-the-art in cooling systems design for injection moulding tools through Computer Aided Engineering (CAE) simulation studies. Virtual 3D Computer Aided Design (CAD) models are constructed using Model Master in Solidworks™ Version 2014, and these used in its Moldflow analysis option to optimise the tool design to include best position for the runner and cooling system for the part. Successively two types of cooling channel are studied: straight holes and conformal channels and a comparison made, with further development routes suggested to refine the design. Solidworks Simulation is particularly suited for this work as it possesses the Mouldflow Plastics Adviser (MPA) tool that can be used exclusively on the virtual solid model of the object, to help the designer to determine the manufacturability of the parts of the mould.

2. OVERVIEW OF THE INJECTION MOULDING PROCESS

The effectiveness of the cooling system is mainly due to the proximity of the coolant. Conformal cooling allows the channels layout close to the cavity surface and thus carrying the heat faster. First objective of conformal cooling is getting a uniform temperature field within the mould and the part. This uniformity avoids and decreases the warpage after ejection of the part.

2.1 Temperature control

Throughout the injection process, the temperature of the plastic has to be controlled constantly from the molten plastic to the solidification of the part as shown in Figure 3.

The channels layout around the mould cavity allows the heat dissipation with liquids such as water or oils used as coolant. Temperature control allows the realisation of a consistently good quality. The main phenomenon which can

appear during the cooling stage is shrinkage (Dimla et al, 2005). A constant pressure within the molten flow has to be maintained during the cooling phase. Warp, which affects the geometry of the final part, is due to an uneven temperature field after ejection.

2.2 Pressure Control

Pressure within the tool assembly is maintained by the clamping system applied hydraulically and held together during the process at the filling and cooling phase. The clamping force varies from part to part according to the frontal area of the part,

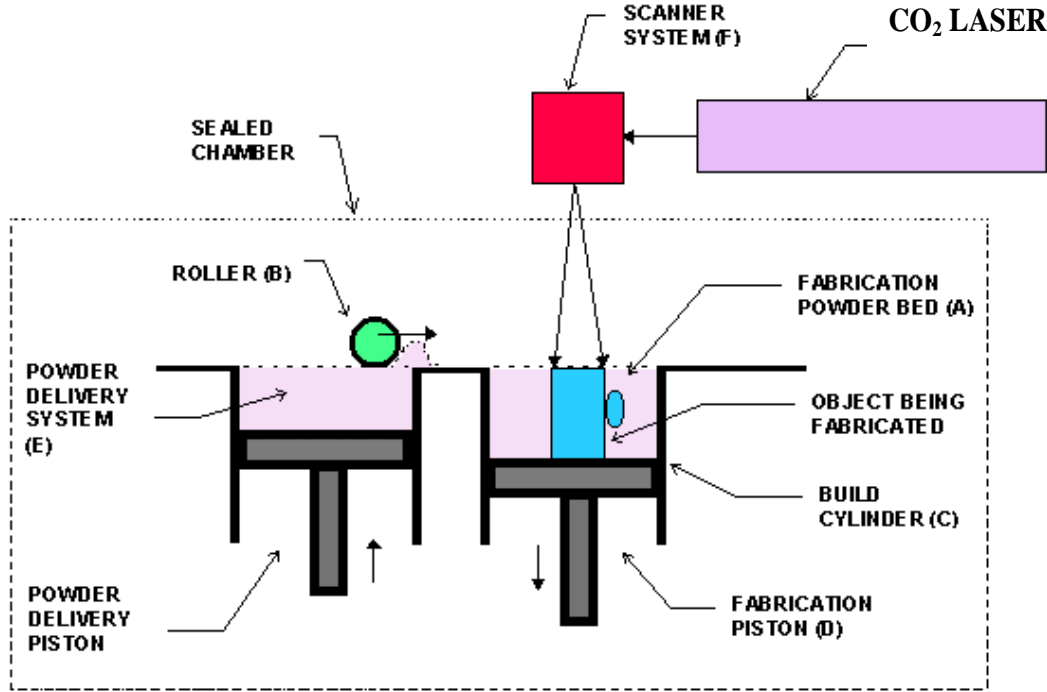

FIGURE 2: CONFIGURATION OF THE SLS PROCESS

the number of cavities, the projected runner area and the pressure inside the cavity. These parameters enable the determination of the clamping force, with the main parameter being the pressure inside the cavity during filling.

2.3 Time Control

The cycle time of the process as a whole will determine the production rate, and as such defines the efficiency of the cost of the final product. The more the machine can produce within a define time, the more the production cost of the part decreases. More than 60% of the cycle time is affiliated to the cooling phase, and factors related to this phase have received particular attention (Hassan et al, 2010a).

2.4 Thermal properties

Thermal features need to be controlled from the start of the process as the molten polymer is injected into the mould cavity to cool. As these characteristics affect the quality of the final product, it is important to have established knowledge of the materials used for both the mould as well as the plastic. Based on thermal exchanges, this factor gives the capability of a material to diffuse heat through a system giving rise to a temperature gradient. Fourier's law helps the understanding of heat behaviour between the cavity and the cooling channels and also the heat convection inside the cooling channels.

To this effect, for this study, simulation studies were conducted using up to date CAE tools. Moldflow is able to

calculate the required time to heat the plastic and then to cool it down within the cavity. The cooling phase is assured by the cooling channels with the cooling time a direct function of their design.

2.5 Cooling channels

The cooling system is one of the most important part of the injection moulding tool assembly. It assures control over the mould and the part temperature considering the layout of the channels within the mould. Once the plastic is injected in the cavity, the heat is extracted with the coolant. Due to the expected production rate, the cycle time has to be decreased as much as possible, with the part and the mould needed to ideally be of a uniform heat field.

Many studies have been conducted to optimise the cooling system, with effectiveness of the channels showing dependency on several factors (Dimla et al, 2005). Hassan et al (2010b) showed through Finite Element Analysis (FEA) that with a similar channel frontal area, the heat dissipation is more important with a rectangular channel than with a circular. Their results showed that the cooling system layout which shows the minimum cooling time not necessarily achieves optimum temperature distribution throughout the product, and the system layout must be optimized to achieve both goals (See Figure 4).

An uneven temperature distribution just before the ejection will bring about partial shrinkage which may then affect the

geometry of the final part. Reaching the mould temperature in less than a cycle enables an equal temperature distribution during the cooling process.

3. OVERVIEW OF CONFORMAL COOLING CHANNELS

Injection moulding remains one of the most exploited industrial processes in the production of plastic parts. Its success relies on the high capability to produce 3D shapes at higher rates than, for example, blow moulding. The longer the time to produce parts the more the costs, thus a reduction in the time spent on cooling the part before it is ejected would drastically increase the production rate, hence reducing costs. It is therefore important to understand and thereby optimise the heat transfer processes within a typical moulding process efficiently. Historically, this has been achieved by creating several straight holes inside the mould (core and cavity) and forcing a cooler liquid to circulate and conduct the excess heat away so the part can be easily ejected. The methods used for producing these holes rely on the conventional machining process such as drilling. However, this simple technology can only create straight holes and so the main problem is the incapability of producing complicated contour-like channels or anything vaguely in three-dimensional space. An alternative to straight drilled and plugged holes is a method that provides a cooling system that 'conforms' to the shape of the part in the core, cavity or both. This method utilises a contour-like channel, constructed as close as possible to the surface of the mould to increase the heat absorption away from the molten plastic, ensuring that the part is cooled uniformly as well as more efficiently. Another advantage is that a mould equipped with conformal channels reaches the operation temperature quicker than a normal one equipped with standard cooling channels. In this way one can reduce the time required when the moulding machine is started, thus increase production to meet the current high demand for plastic products quicker.

Using FEA, Agazzi et al (2013) determined the optimal distribution of coolant along a cooling surface. From the heat transfer analysis of the mould, employing thermal analysis, conformal cooling channels were designed according to the shapes of isotherms. A channel improvement is achieved, avoiding problems of flow circulation.

Wanga et al (2011) found a method that automatically created conformal channels around the part, using an algorithm. First, the original part is offset a predetermined distance, then an algorithm creates a Centroidal Voronoi Diagram and compared with a traditional cooling system manufactured with conventional tools. A significant time saving was demonstrably achieved on the cooling phase, as the channels are closer to the surface; the heat dissipation is more efficient. Shrinkage analysis also shows that the efficiency of this method of designing conformal cooling channels to be slightly improved compared to conventional channels through experiments on cell phone shaped CAD models.

Jauregui-Becker et al (2013) proposed a way of designing cooling channels through design automation based on splitting the geometry's part and then the application of three techniques used collaboratively allowing the generation of the model. The mould is split into a voxel mesh, and then grids of points superimposed with simple colour codes assimilated to the grid points, and then channels created from each property of these points. From their experiment, it is shown that a higher number of cooling channels with smaller diameters gives a better result, thus the warpage effect is decreased.

Jiang and Lu (2007) built a model showing temperature distribution and the heat transfer in a porous media without thermal contact resistance, that indicate larger than those which is consistent with the experimental results. This method offers an alternative to achieve a more uniform cooling within the mould and the polymer, with a wider surface in contact with the coolant, thus, the heat dissipation is increased and the possibility of removing much more heat than other conformal cooling channels.

3.1 Manufacturing of conformal channels

Laser sintering/melting are the main methods utilized in the manufacture of metallic 3D solid objects from a CAD model. The process allows the direct manufacture of 3D shapes by printing out using an additive process, where layers of material powder are laid down one after another. Each time a layer is laid down, a laser melts off the desired cross section according to the CAD model, thereby allowing the atoms of the metallic powder to bond together forming a consistent layer of the material. The main advantage of this kind of process lies in the freedom of the designer. Indeed the complexity of the part doesn't affect the manufacturing process.

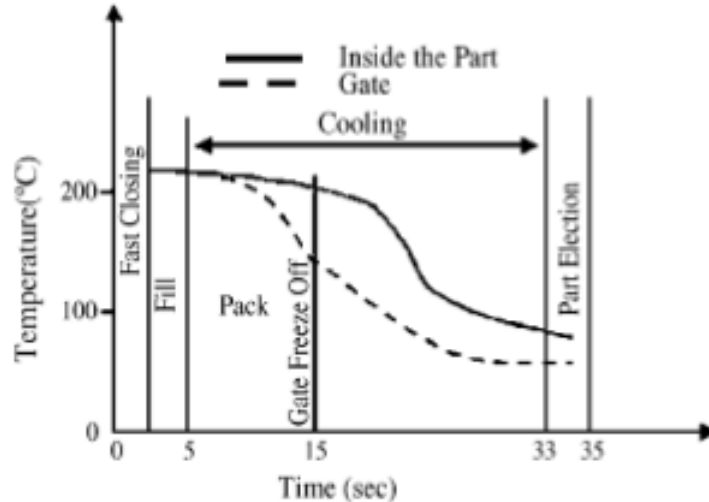

FIGURE 3: TEMPERATURE HISTORY DURING THE INJECTION MouldING PROCESS (DIMLA ET AL. 2005)

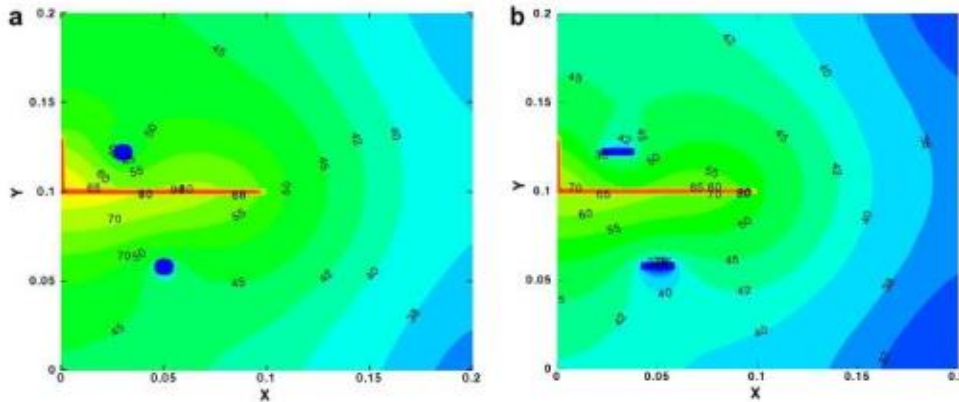

FIGURE 4: TEMPERATURE DISTRIBUTION THROUGH THE Mould FOR DIFFERENT COOLING CHANNELS FORMS (A) CIRCULAR AND (B) RECTANGULAR HAVING THE SAME CROSS SECTIONAL AREA

The design of the part used for this study has been chosen randomly (Figure 5). It is a dog bowl with a uniform material thickness of 2.5 mm, made from a generic polymer: Polypropylene.

4. INJECTION MouldING ANALYSIS

Using Moldflow Adviser, a theoretical approximation of the filling time, the product quality, best location of the injection point and other characteristics can be obtained. As the modification of a mould after it has been manufactured would be very costly, CAE gives information about the design, which could be acted upon to improve the tool performance before it is actually manufactured. In this part of the analysis, we focus on the visualization and analysis of the tool performance through simulation studies, with the material being Polypropylene injected into the cavity at a melting temperature of 240°C and the mould temperature kept at 40°C.

4.1 Flow front analysis

Several experiments have been conducted to the understanding of the molten polymer movement within the cavity. The flow front is mainly led by viscosity of the plastic and the more it is cooled down the more it tends to be viscous and solidifies. Mouldflow™ software implements the main governing equations of mass, momentum and energy transport, with appropriate boundary conditions at the injection point, the mould walls and flow front regions. An example, plastic behaviour during the filling is shown in Figure 6.

With 1 injection point located at the centre of the part, the flow front is circular, and fills the entire cavity in about two seconds (Figure 7). Trying several dispositions (more than one injection point) decreases the filling time but not too drastically. It also decreases the injection pressure, and changing this parameter induced other problems. The choice is mainly driven by the desired quality for the product or the solid state morphology of the polymer.

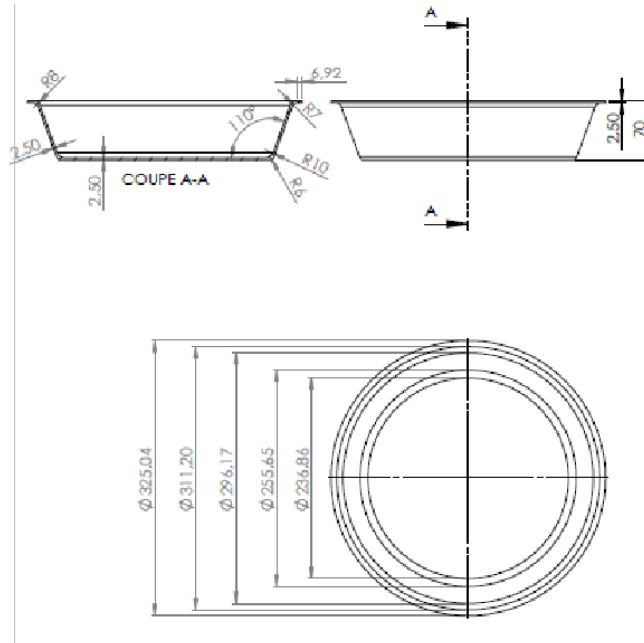

FIGURE 5: 2D REPRESENTATION OF THE PART



FIGURE 6: FLOW FRONT OF THE MOLTEN POLYMER WITHIN THE CAVITY WITH ONE CENTRAL INJECTION POINT

With several injection points (Figure 8), injection pressure decreases slightly and the filling time when compared with one injection point is less. The major problems noticed in these conditions are weld lines between each flow front and air bubbles (Figure 9). They are confined between each front or behind the flow and the mould wall. These lines involve a discontinuity within the material, which weakens the moulded part, and may cause failure if the part is under sufficient stress in the product's lifetime.

With several or only one injection point, the forecast quality of the part on the lower corner of the model is indicated as of poor quality (3% of the part).

This forecast quality preview (Figure 10A) shows that within the rounded areas, there may appear some quality defects, originating from variation of the part geometry, as there are indeed two different radii. By changing this radius from 6mm to 10mm, MPA gives a forecast quality of 100% (Figure 10b). The optimal solution seems to be with one injection gate

in the centre of the mould. This configuration generates a proper geometry without air bubbles or weld lines.

4.3 Design of the cooling system

According to the current design, the clamp force acting on the mould is approximated to be 15.4 tons. This force keeps the core and cavity together during the injection process while the pressure acting inside during the filling can reach 17.3 MPa. Adequate parting lines have been chosen to part the two mould halves as shown in Figure 11.

Straight cooling channels

Straight cooling channels have been used for a long time and are the de facto cooling method due to their ease to manufacture (Figure 12A). The main disadvantage of these cooling channels remains the uneven uniformity of the heat exchange between the channels and the part. It produces either a longer cycle time or geometric fault, such as shrinkage and warpage.

Conformal cooling channels

Conformal cooling channels are laid on an offset plane above the shape of the cavity (Figure 12B). If the product is thin, then channels must be placed within the same gap. In this case channels have been placed 1mm close to the mould wall and with a gap of 17mm, with pipes of constant section. There can be several inlets and outlet channels which enable maintaining a constant temperature. This configuration with

the channels closer to the mould should give a more homogeneous cooling, as the heat diffused from the molten polymer is extracted quicker by the coolant.

In all aforementioned design, ejectors have not been taken into account. The part has to be integrated within the mechanism enabling the ejection of the part when the core and cavity open after cooling.

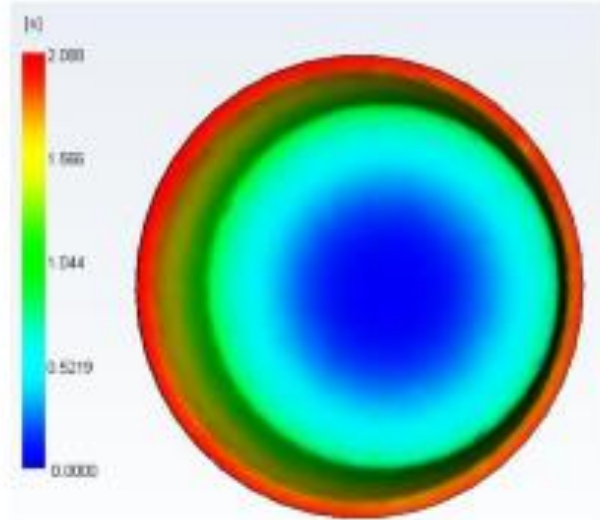

FIGURE 7: FILLING TIME WITH ONE INJECTION POINT

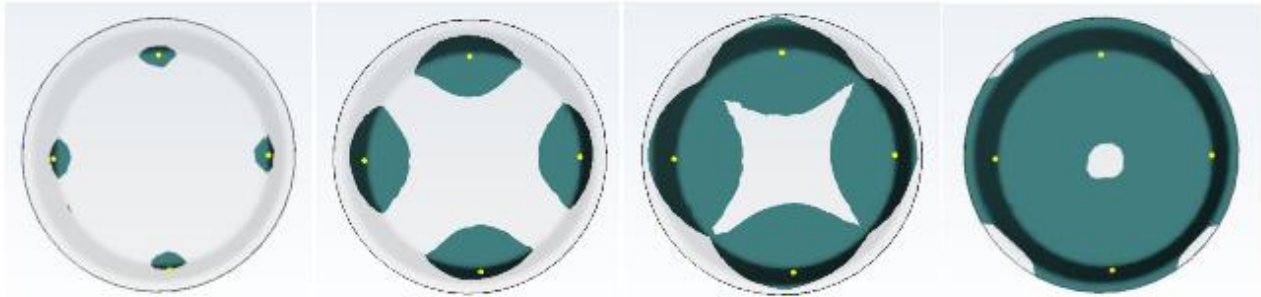

FIGURE 8: FLOW FRONT OF THE MOLTEN POLYMER WITHIN THE CAVITY WITH FOUR INJECTION POINTS

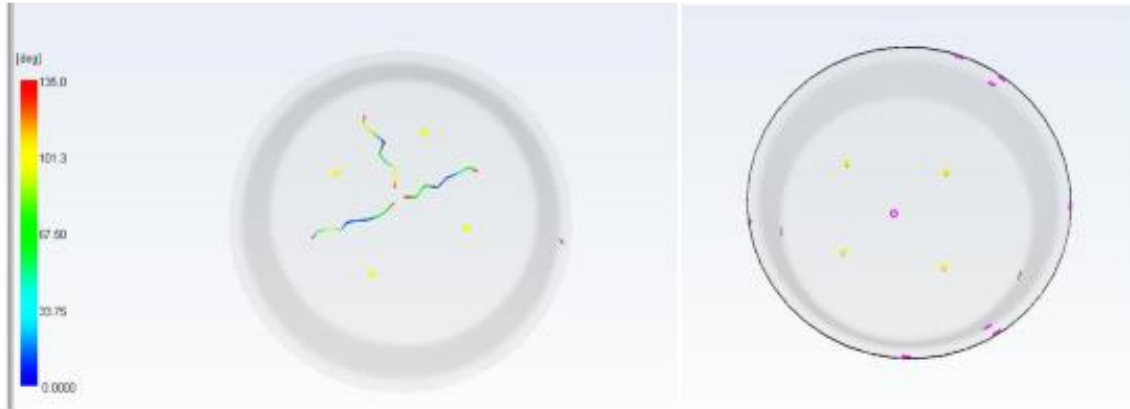

FIGURE 9: WELD LINES SPOTTED AT EACH FLOW FRONT (LEFT) AND BUBBLES CAUSED BY THE FLOW FRONTS (RIGHT)

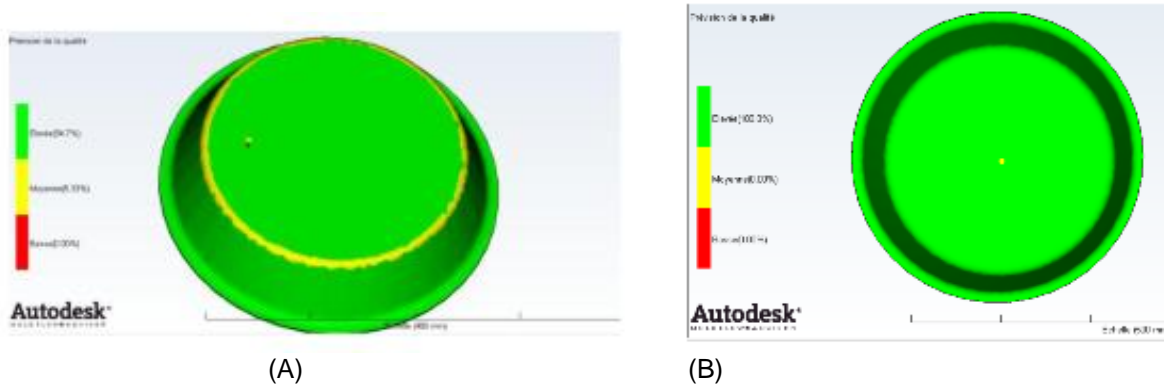

FIGURE 10: QUALITY OF THE PART (A) AND FORECAST QUALITY OF THE PART AFTER RADIUS MODIFICATION (B)

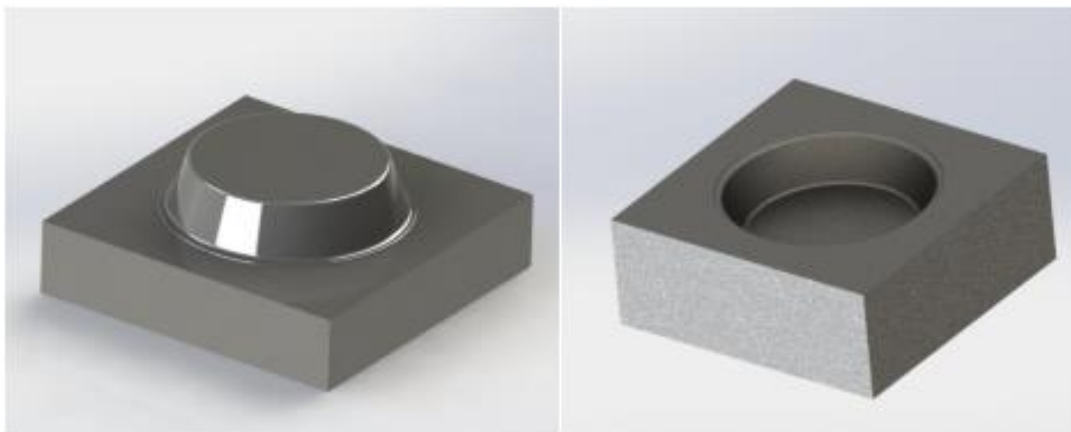
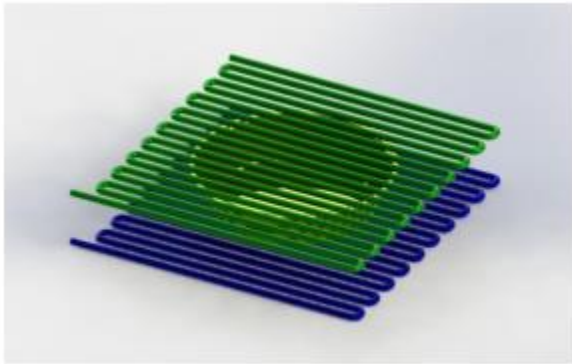

FIGURE 11: CORE CAVITY OF THE MOULD



(A)



(B)

FIGURE 12: STRAIGHT COOLING CHANNELS (A) AND CONFORMAL COOLING CHANNELS (B) APPLIED OVER THE MODEL.

5. CONCLUSIONS

The investigation has shown that it is possible to develop and use virtual 3D CAD models in determining an optimum and efficient design for conformally cooled channels in the configuration of an injection moulding tool. Their effectiveness has also been analysed and compared in the prediction of cooling times or other thermal analyses. Hopefully, with further work and advances in the simulation using FEA, the study should culminate in the suggestion of the level of proficiency required using virtual models in deciding moulding specifications for production parts.

Problems were encountered during the meshing intersections between the upper and the lower face of the cooling cavity with several irregularities highlighted. It is planned to be addressed in furthering this study in the near future.

REFERENCES

- 1 Crawford R (1998). *Plastics Engineering*. Oxford, Butterworth-Heinemann
- 2 Ring M, Dimla D E, Wimpenny W (2002). An Investigation of the effectiveness of Conformal Cooling channels and Selective Laser Sintering material in injection moulding tools. RPD 2002 Advanced Solutions in Product Development, October 6-11th, Miranda Grande, Portugal
- 3 Chua C K, Leong K F, Lim C S (2010). *Rapid Prototyping: Principles and Applications*. Third Edition, World Scientific Publishing Co. Pte. Ltd. Singapore
- 4 Dimla D E, Camilotto M, Miani F (2005). Design and optimisation of conformal cooling channels in injection moulding tools. *Journal of Materials Processing Technology*. 164, 1294-1300.
- 5 Hassan H, Regnier N, Le Bot C, Defaye G. (2010a). 3D study of cooling system effect on the heat transfer during polymer injection molding. *International Journal of Thermal Sciences*. 49, 161-169.
- 6 Hassan H, Regnier N, Pujos C, Arquis E, Defaye G (2010b). Modelling the effect of cooling system on the shrinkage and temperature of the polymer by injection molding. *Applied Thermal Engineering*. 30, 1547-1557.
- 7 Wang G, Zhao G, Li H, Guan Y (2011). Multi-objective optimization design of the heating/cooling channels of the steam-heating rapid thermal response mold using particle swarm optimization. *International Journal of Thermal Sciences*. 50, 790-802.
- 8 Agazzi A, Sobotka V, LeGoff R, Jarny Y (2013). Optimal cooling design in injection moulding process - A new approach based on morphological surfaces. *Applied Thermal Engineering*. 52, 170-178.
- 9 Jauregui-Becker M, Tosello G, van Houten F, Hansen N (2013). Performance evaluation of a software engineering tool for automated design of cooling systems in injection moulding. *Procedia CIRP*. 7, 270-275.
- 10 Au K, Yu K (2011). Modelling of multi-connected porous passageway for mould cooling. *Computer-Aided Design*. 43, 989-1000.
- 11 Jiang P, Lu X (2007). Numerical simulation and theoretical analysis of thermal boundary characteristics of convection heat transfer in porous media. *International Journal of Heat and Fluid Flow*. 28, 1144-1156.