

*This paper was recommended for publication in revised form by Regional Editor Jovana Radulovic*

## **INVESTIGATION OF THERMOFORMING TOOL DESIGN AND POCKET QUALITY**

### **\*Moustafa Moustafa**

School of Engineering, University of Portsmouth,  
Anglesea Building, Portsmouth, PO1 3DJ, UK

### **Krassimir Dotchev**

School of Engineering, University of Portsmouth,  
Anglesea Building, Portsmouth, PO1 3DJ, UK

### **Simon Wells**

Adaptsys Ltd.  
Rotherbrook Court,  
Bedford Road, Petersfield,  
GU32 3QG, UK

### **Nick Bennett**

School of Engineering,  
University of Portsmouth,  
Anglesea Building, Portsmouth,  
PO1 3DJ, UK

### **James Cawkell**

Adaptsys Ltd.  
Rotherbrook Court,  
Bedford Road, Petersfield,  
GU32 3QG, UK

*Keywords: Thermoforming, Mould tool, Carrier tape, 3D rapid manufacturing*

*\* Corresponding author: M. Moustafa, Phone: +441730262444, Fax: +441730262333*

*E-mail address: moustafa.moustafa@port.ac.uk*

## **ABSTRACT**

Thermoforming is widely used in manufacturing industries to produce a range of polymer products. The Reflex tape thermoforming system is designed to form flat tape film into pockets. These formed pockets, also called carrier tape, are used in numerous applications to package a large variety of electronic or small mechanical parts. Thermoformed pocket walls are generally not uniform in thickness and often break during the forming process. Uniform wall thickness distribution, especially for deep pockets, plays significant role on pocket quality improvement and scrap reduction. This paper investigates the influence of the tool design, tool material, and some thermoforming process parameters on wall thickness distribution in formed pockets using polymer flat films. Conventional tool and a hybrid tool with 3d printed inserts were used in the experiments. The process parameters, plastic film and tool set temperatures were controlled by the Reflex machine and also measured using infrared thermometer and thermocouple. Film temperature ranges from 150 to 200 °C and a range of tool set temperatures (40 to 85°C) were used in the thermoforming. It has been found that the temperature difference between the plastic film and the forming tool was important for uniform wall thickness distribution. The results from this experimental study concluded that the most influential factors for good pocket quality are the tool design, tool

material, and heat transfer dynamics in the plastic film - tool set system. Another aim of the study was to investigate the viability of the 3D printing process to manufacture rapidly tool inserts compared to conventional CNC machining.

## **INTRODUCTION**

Thermoforming is reshaping process in which a flat thermoplastic sheet or film is heated and shaped into moulded parts. Extruded sheet is heated to its softening temperature, clamped around its edge and formed to the required shape by mechanical stretching and applying a pressure. The softening temperature depends upon the thermoplastic material properties [1]. Mechanical stretching is carried out using mould, thermoforming tools. The force required to stretch the film can be provided by mechanical pressure, vacuum, air pressure, hydraulic pressure, or combinations of these. When the thermoplastic film contacts with the surface of the mould for some time, the softened material cools down and is held against mould surface until the sheet become rigid. Forming temperature, depending upon specific material type, ranges from 120° to 370 °C [2].

There are many different thermoforming techniques. Depending on which side of the forming material comes into contact with the forming tool, the procedure is referred to as positive or negative forming. With positive forming, the inside

of the article is reproduced precisely, because that is the side in contact with the thermoforming tool [1]. The main techniques of thermoforming currently used are vacuum, pressure, and plug-assist thermoforming [3-6]. In this study, positive pressure forming method is investigated. Also, air pressure is used to force heated plastic sheet against the mould surface to get a highly defined product surface [7, 8].

The positive pressure forming process is one of the most popular thermoforming methods used in polymer processing. It is a cost effective manufacturing method that produces flexible, strong, well defined, and durable parts. Highly detailed complex and large parts can be formed economically [9, 10]. Furthermore, very thin walled parts can be produced from forming material with the thermoforming [11]. Wide application of thermoforming is due to its easiness of production, high performance, cost-efficiency of thermoforming tools, the possibility for processing multi-layered materials, and reasonably priced thermoforming machines [1].

Due to well defined and excellent optical properties of produced parts, easiness of production, low cost, and high performance, thermoformed plastic carrier tapes are widely used to package electronic or mechanical parts [12]. Carrier tapes contain small pockets, in which the component sits, that vary in both shape and dimension. The design of the cavities in carrier tapes is based on the component dimensions; length, width, and height. The design of carrier tapes must meet the EIA-481 standards [13]. Carrier tape serves as a physical protection for the component during transportation and promotes assembly automation as a method of accurate positioning for the pick and place machines [12, 14]. Carrier tapes must be manufactured to comply to the required dimensionally accuracy typically  $\pm \frac{1}{2}$  IT9 -IT10. Therefore, correct carrier tape tool design and efficient manufacturing play an important role in all downstream manufacturing processes in terms of productivity and quality of components packaging, transportation and assembly.

There are certain limitations and problems in the thermoforming process. Depending on the process employed, only one side of the moulding has a perfect replica of the tool's geometry. The contours of the opposite surface are less defined as a result from having been stretched [1]. Furthermore, thermoforming is a differential stretching process. Therefore, pocket walls are generally non uniform in thickness. Non uniform wall thickness and thinning at pocket base corners and sometimes wall breaking are unwanted phenomena in thermoforming. The structural performance of the carrier tape depends on wall thickness. In order to protect the electronic components inside of the carrier tape pockets during transportation and keep their orientation, wall thickness of the pockets should be uniform and their strength should be sufficient. Also, if non uniform wall thickness and thinning occurs, it will lead to tear, bad carrier tape quality and production inefficiency.

Therefore, it is important to maintain pocket wall thickness distribution constant and prevent thinning during the thermoforming process.

Most thermoforming systems use sheet or film that is fed from a reel. Reels are usually 7, 13, and 22 inch in diameter and up to 2000 meters in length. The standard tape widths are 8, 12, 16, 24, 32, 44, 56, 72 mm. In this study, the thermoforming machine accepts tape film from a large input reel [8] having width 16 mm.

During the thermoforming process, it is vital to understand the effects of input parameters (machine setup, tool design, tool material, tape material, etc.) on the wall thickness distribution. There is an increased research in the area of thermoforming studying wall thickness distribution of thermoformed components. The influence of various factors such as tool temperature, speed, geometry and materials, and film temperature and materials on the wall thickness distribution of thermoformed products have been studied by various researchers [3-6, 14, 15]. Many researchers agreed that the heat transfer between mould tool and plastic film material plays an important role in thermoforming process.

Ayhan and Zhang [5] reported that the wall thickness was significantly affected by forming temperature, forming pressure, and heating time. Erdogan and Eksi [6] investigated the effect of three different types of mould tools on the wall thickness distributions. It was reported that clamping tool geometry must be selected according to the geometry of the product in order to have more uniform wall thickness distributions. Song et al. [16] investigated the effect of heat transfer between material and forming tool on wall thickness distribution by simulating and predicting thermal stress. It was concluded that for plastic thermoforming, there was direct relationship between the temperature distribution and the thickness distribution.

Heat flows from the higher temperature film to the mould at a lower temperature. This heat flow is affected by the thermal contact conductance (TCC) between the mould and the film material. Research on TCC between various polymeric materials and aluminium was carried out by Marotta and Fletcher [17]. The researchers examined the effect of interface pressure on the TCC and found an increase of TCC with increasing pressure. Narh and Sridhar [18] studied TCC between PS and mould steel. It was reported that the transition temperature of polymers is an important parameter in defining a TCC model. There is little research on TCC when using non-metal mould tools.

In this study, the wall thickness distributions produced with four different mould tool materials were studied using experimental methods. Since wall thickness distribution has a direct relationship with heat transfer from the heated tape to the mould tool during thermoforming, thermal conductivity of the mould tool material and its influence on heat transfer and wall thickness distribution were investigated.

## METHODOLOGY

### Carrier Tape Material

Proper carrier tape material minimizes part migration, flipping during transportation, and mis-picks during the pick-and-place process. There are three standard carrier tape materials; paper, embossed polystyrene plastic, and embossed polycarbonate plastic. Embossed polystyrene is more expensive but provides a superior level of component protection to paper. Polycarbonate offers the best protection as well as the highest price tag. Typically, the carrier tape is constructed from a polystyrene (PS) or PS-laminate film. The film thickness is 0.2 mm to 0.5 mm, depending on the size and weight of the component carried by the tape.

Tri-laminate conductive polystyrene- acrylonitrile-butadiene-styrene (PS-ABS-PS) material films were used in these experimental studies. Polystyrene is a very common thermoplastic with many different applications and ideal for thermoforming packaging process. It has high resistance to crack initiation. Conductive PS protects the content of transport pockets and packaging from static fields. ABS is a durable, rigid thermoplastic with rubber like characteristics. The softening temperature of the PS-ABS-PS is 97°C. This multilayer material provides additional mechanical and thermal properties in packaging applications.

### Mould Tool Materials

A hybrid mould tool that allows exchangeable inserts made of different materials (Figure 3) has been designed and manufactured. CNC machining and 3D printing were employed to produce the inserts from Aluminium alloy, Acetal, high temperature HTM140 resin [21] and ABS material [22]. Experiments with each mould tool insert, have been carried out using the same processing parameters.

### Equipment

The thermoforming machine used in this study was the Reflex™ On Demand tape forming machine shown in Figure 1, developed and patented by Adaptsys Ltd. It is controlled via a touch screen PC running on Microsoft Windows XP operating system (OS). The OS runs a custom operator interface and controls various inputs and outputs to allow the system to operate. The system consists of a PC Operator Control, electrical and electronic cabinet, air pressure pump, reel delivery assembly, tool module set and vision inspection system. The Reflex™ ODT (On Demand Tape) System is designed to accept thermoplastic flat tape film from a large input reel that passes through exchangeable thermoforming tool module (Figure 2) which heats the tape and then forms it into pockets. These formed pockets, called Carrier Tape, can then be wound onto an output reel or the system can be connected to a downstream Tape & Reel system to allow the carrier tape to be filled with parts and sealed (Figure 1). Carrier Tape is used in

numerous industries to package a large variety of electronic or mechanical parts, in order to transport them from the manufacturer to the end user.

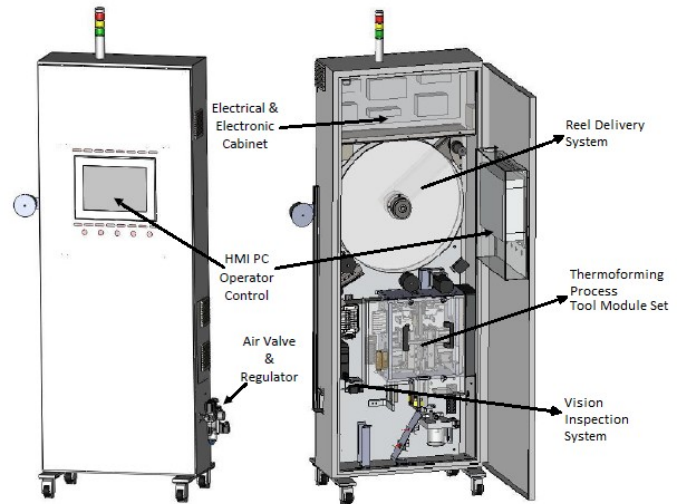

FIGURE 1 REFLEX™ ON DEMAND TAPE THERMOFORMING MACHINE (ADAPTSYS LTD.)

The tool module set at the Reflex machine is designed to form pockets into a tape using thermoforming techniques. The tool set is comprised of three main components: tape guide, mould, and assist (Figure 2). Tape guide ensures that the carrier tape is fed down accurately. The preheat blocks and mould set tools are heated up to certain temperature in order to soften pocket areas that will be subsequently formed. Mould and Assist blocks are advanced against each other with the tape in between to form the pocket in the tape by the pneumatic cylinders in the tool actuator assembly. A set of punch pins and die buttons located in the tool set could punch a round hole in the bottom of each pocket after forming (optional operation). A vacuum pump is connected to the assist to draw away the waste.

A Mitutoyo Model 112-153 point micrometre (Tokyo, Japan) was used to measure the thickness of formed pockets. The micrometre measures in the range of 0-25 mm (0-1 inch) with 0.01 mm sensitivity and 15° tip angle.

A RayTemp™ 4 infrared thermometer was used to measure the surface temperature of the tool sets and carrier tape. The thermometer is equipped with a 9:1 optic ratio (target distance/diameter ratio) with a laser dot alignment. The thermometer is capable of measuring over the range of -50 to 400° C with an assured accuracy of ±1 °C of reading in an ambient temperature of between 15 °C and 25 °C. It also has a repeatability of ±1 °C of reading with 1.0 s average response time.

Standard ST-9612 thermometer was also used to measure the surface temperature of the mould and assist tools during the thermoforming process. This digital thermometer is designed for use with external Type K thermocouples as

temperature sensors. It measures temperatures over the range of -50 °C up to 1300 °C and provides the accuracy to  $\pm 0.5\%$ .

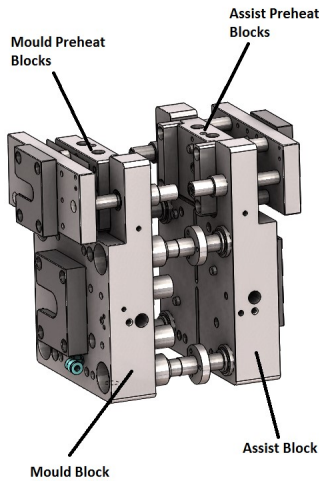

FIGURE 2 TOOL MODULE SET

**Experimental Procedure**

The forming technique used in this experimental study is similar to ‘positive forming’ or pressure forming. The inside of the carrier tape pocket is reproduced precisely by the forming tool, while the outside shape is achieved by using additional positive air pressure. In this positive forming method, the wall thickness of the pocket is greater at the bottom than at the rim.

Standard flat tape film in 16 mm wide and 0.3 mm thickness from large input reel was used. It has pre punched sprocket holes which are used to index and drive the tape following the process operations.

Only the areas of the pockets in the tape were heated to approximately 190°C with two preheat blocks for about 200 msec. The forming takes about 400 msec including the moulding operation and application of 80 psi air pressure coming from the assist tool to push the heated carrier tape into the shape of the mould. The air pressure promotes create greater detail, sharp corners and textured surfaces at carrier tape pockets. When the mould insert is advanced, the carrier tape is stretched into the air pressure box. During the forming process, pockets were cooled by the mould (70°C) and air pressure (20°C).

Cooling and solidification of the carrier tape pockets are the longest stages of the whole forming process. If the cooling time is too long, the deforming cycle is affected and the productivity decreases. If the cooling time is too short, then unevenly distributed temperature field causes, several problems, such as non-uniform wall thickness, tears, poorly defined pockets. Process parameters such as: preheat close time, forming close time, cool air temperature, cool air close time, and tools temperatures for this study were determined empirically by an iterative procedure involving several tests.

In this study, four different materials for the mould insert were used (Figure 3). The dimensions of each insert are 55 x 36 x 20 mm.

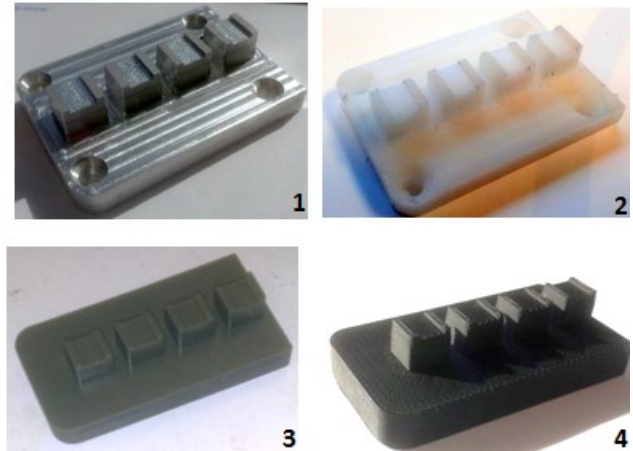

FIGURE 3 THERMOFORMING MOULD INSERTS; (1) AL INSERT - CNC MACHINED, (2) ACETAL INSERT - CNC MACHINED, (3) HTM140 INSERT – 3D PRINTED AT ENVISION TEC PERFACORY, AUREUS, (4) ABS INSERT - 3D PRINTED AT DIMENSION1200ES

They were mounted to the main mould blocks with four screws. Four cavities were formed when the tool set was advanced (Figure 4).



FIGURE 4 CARRIER TAPE FORMED POCKETS

The film temperatures used in this study were between 160 °C to 200 °C and tool set temperatures were between 50°C and 75°C. After each thermoforming process with these four inserts, the carrier tape pockets samples were cut vertically to measure wall thickness distribution. Wall thickness values were measured from point-A to point-G (Figure 5). The wall thickness measurements were performed on at least eight different formed pockets for each inserts. Each measurement was repeated at least three times using the point micrometer.

During the forming process, temperatures of the mould inserts were also measured with the infrared probe and digital Type K thermocouple thermometer. The infrared thermometer probe was placed under the plastic film facing the PS-ABS-PS side and the temperature was recorded manually immediately before the forming process.

Mean wall thicknesses and wall thickness variation factors were calculated. The obtained wall thickness measurements from the mould inserts were compared with each

other. Effect of mould materials and their temperature on pocket wall thickness distribution were investigated.

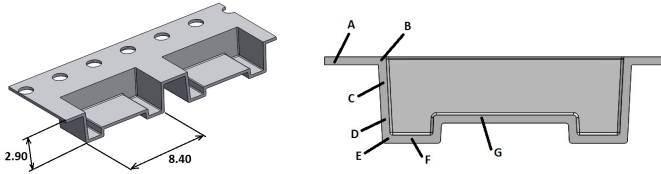

FIGURE 5 3D SIDE CUT VIEW OF THE FORMED POCKETS AND POCKET WALL THICKNESS MEASUREMENT POINTS

**RESULTS AND DISCUSSION**

Analysis of wall thickness data showed that mould insert material, forming temperature, and forming time affected wall thickness distribution of the thermoformed pockets. The wall thickness can vary from 0.1 to 0.3 mm.

It was observed that thermoforming could not be completed when the ABS mould insert (made by FDM rapid manufacturing) was used. Due to low surface quality the mould insert could not be retracted without deforming pockets during thermoforming process. After the couple of forming operations the pockets were deformed and surface quality deteriorated. Therefore, the ABS insert was rejected for further tests. Mean wall thickness distribution with the ABS insert is presented in Figure 6.

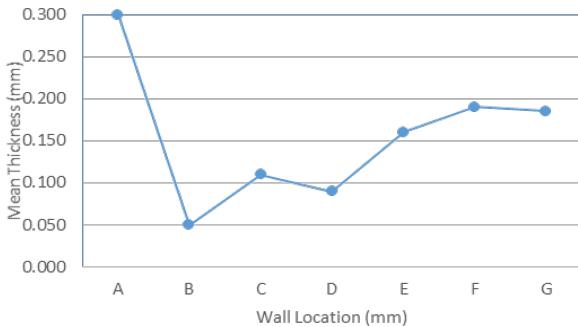

FIGURE 6 WALL THICKNESS DISTRIBUTION WITH THE ABS MOULD INSERT

The wall thickness near the pocket side (point-C) was 0.11 mm, whereas at the top (point-B) was 0.05 mm. This wall thickness distribution is not acceptable (Figure 6). The measured tool temperature, 50°C was below the set temperature, 65°C of the Reflex machine. This was due to low thermal conductivity of the ABS mould insert.

In general, the wall thickness at the side wall of the pocket was about three times lower than at the top of the pocket. The film temperatures used in this investigation were above the 97°C softening temperature of the PS-ABS-PS.

Therefore, effect of film temperature did not play important role on wall thickness distribution during the thermoforming of the carrier tape pockets. Preheat temperature of 190°C was used to heat the film for each mould inserts.

Figure 7 illustrates the mean wall thicknesses obtained with the other three mould inserts. Despite the small variation there is no significant difference at point-D between the mean thicknesses of the pockets produced with the inserts.

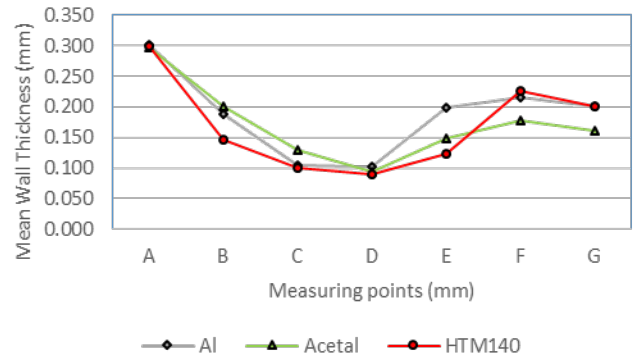

FIGURE 7 COMPARISON OF WALL THICKNESS FOR CARRIER TAPE POCKETS PRODUCED BY AL, ACETAL AND HTM140 MOULD MATERIAL INSERTS

Forming temperature with the Acetal mould tool was lowered to 60°C. This was done to create well defined pockets and to provide continuity of the thermoforming process. Wall thicknesses at the sides of the pockets (point-B and C) produced by the Acetal insert were higher than other inserts, whereas the wall thicknesses near the pocket base were lower than pockets produced by the Al insert (Figure 7). The thinnest wall thickness at point-B, C, D, and E was observed pockets produced by the 3D printed mould insert, material HTM140. Forming temperature for this insert, material HTM140 was 70 °C. However, during the thermoforming process, it was observed that temperature of the insert was increased to 95-100°C due to heat transfer from preheated carrier tape. HTM140 responded slowly for cooling down process. Therefore, well defined, similar to the pockets manufactured with the Al insert could not be produced after approximately eight times forming (Figure 8). The pockets did not have uniform shape. The quickest manufactured inserts were the 3D printed HTM140 and ABS mould tool inserts.



FIGURE 8 CARRIER TAPE POCKETS PRODUCED BY THE HTM140 MOULD INSERT

Uniform wall thickness was obtained in the pocket wall location range of C to D during thermoforming with the Al insert. There is no significant difference between the pocket wall thicknesses means obtained with the Al mould inserts. Al insert responded rapidly to the heat transfer and the forming temperature were kept between the 65°C to 75°C. Well defined and uniform pockets were produced (Figure 9).

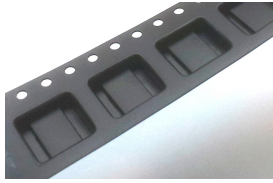

FIGURE 9 CARRIER TAPE POCKETS PRODUCED BY THE AL MOULD INSERT

In general, it was observed that thermoforming could not be continued when the short closing time of 200 ms and the low tool temperatures of 50°C were used due to cooling of the film below its plastic softening point during the thermoforming process. Visual observation of edge sharpness, pocket definition and the final pocket shape has been used as a criteria for process quality. It has been found that the best definition can be obtained when using Al inserts. In all other cases, when using non-metal mould inserts, the final pocket shape was not well maintained. A possible reason could be the use of process parameters optimised for Aluminium tool inserts in all tests.

## CONCLUSION

Preliminary test results demonstrated the major advantage of thermoforming with the Al mould insert tool over thermoforming with the Acetal, HTM140 and ABS mould insert tools for carrier tape pockets production. The experiments performed on the thermoformed products showed that in order to produce carrier tape pockets that have more uniform wall thickness distributions, thermal conductivity must be high and forming temperature must be kept constant. Wall thickness distribution results have changed with the mould materials used in thermoforming simulation. However, there were minor differences between thickness distribution results.

A motivation for using non-metal thermoforming inserts was to reduce mould too manufacturing time and cost. Typically, the CNC machining of engineering plastics could take up to two times less than machining of Aluminium. Also, rapid manufacturing using non-metal materials could be even faster and cheaper in the future. Further work is required in order to investigate whether a specific setup of the thermoforming parameters would improve the definition of the pocket shape when using non-metal inserts.

More tests would be required to confirm the effect of these materials on the carrier tape production process. More work has

to be carried out to assess accuracy and repeatability of the results obtained.

Work is currently under way to study how to reduce the time and cost not only in the tooling manufacturing but for the whole process carrier tape production using the Reflex carrier tape manufacturing machine in order to deliver a rapid bespoke service.

## ACKNOWLEDGMENTS

The Authors would like to thank and acknowledge the funding and support of the UK government funded programme Knowledge Transfer Partnerships (KTP Project Nu 4113), Adaptsys Ltd. (Petersfield, UK), and the Regional Centre for Manufacturing Industry ( School of Engineering, University of Portsmouth).

## REFERENCES

- [1] Illig Adolf, (2001). Thermoforming A Practical Guide, Hanser Publishers, Munich.
- [2] Throne, J. L., (2008). Understanding Thermoforming, 2<sup>nd</sup> Edition, Hanser Publishers, Munich.
- [3] Throne, J.L. (1991). Guidelines for thermoforming part wall thickness. *Polymer-Plastics Technology and Engineering*, vol.30, no. 7, p.685-700, DOI: 10.1080/03602559108020144.
- [4] Aroujalian, A., Ngadi, M.O., and Emond, J-P. (1997): Wall Thickness Distribution in Plug-Assist Vacuum Formed Strawberry Containers. *Polymer Engineering and Science*, Vol.37, No.1, 178-182
- [5] Ayhan Z., Zhang, Q.H. (2000); Wall Thickness Distribution in Thermoformed Food Containers Produced by a Benco Aseptic Packaging Machine. *Polymer Engineering and Science*, Vol.40, No.1, 1-10
- [6] Erdogan, E.S. and Eksi, O. (2014); Prediction of Wall Thickness Distribution in Simple Thermoforming Moulds. *Journal of Mechanical Engineering* 60(2014)3, 195-202
- [7] Boser, L.M. (2003): *Thermoforming Manual and Trouble-Shooting Guide*
- [8] Adaptsys Ltd.Re-flex On-Demand Tape Carrier Tape Forming System Operation & Maintenance Manual Version 3.
- [9] Azdast, T., Doniavi, A., Ahmadi, S.R., Amiri, E. (2013); Numerical and experimental analysis of wall thickness variation of a hemispherical PMMA sheet in thermoforming process. *Int. J. Adv. Manuf. Technol.* 64-113-122.
- [10] Gruenwald, G. (1987): *Thermoforming: a plastics processing guide*. Technomic, Lancaster
- [11] Throne, J.L., Mooney, P.J. (2005). Thermoforming: growth and evolution I. *Thermoforming Quarterly*, vol. 24, no. 1, p. 18-20.
- [12] Adaptsys Ltd., Carrier Tapes, Device Programmers, Tape & Reel Systems; <http://www.adaptsys.com/>, (Accessed in 2015).
- [13] EIA-481-D, Electronic Components Association Standards. 8 mm through 200 mm embossed carrier taping and

8 mm & 12 mm punched carrier taping of surface mount components for automatic handling, USA, July 2008

[14] Throne, J.L. (1991). Guidelines for thermoforming part wall thickness. *Polymer-Plastics Technology and Engineering*. Vol. 30, no. 7, p.685-700, DOI: 10.1080/03602559108020144

[15] R. McCool, P.J. Martin and E. Harkin-Jones, (2006); 'Process modelling for control of product wall thickness in thermoforming', *Plastics, Rubber and Composites*, 35, 340-347

[16] Song , Y. Zhang, K. F., Wang, Z. R., and Diao, F.X. (2000), Coupled Thermo-Mechanical Analysis for plastic thermoforming; *Polymer Engineering and Science*, Vol. 40, No.8

[17] Marotta, E.E., and Fletcher, L, (1996), Thermal contact conductance of selected polymeric materials, *Journal of Thermophysics and Heat Transfer*, 10, 334-342.

[18] Narh, K. A., and Sridhar, L., (1997) Measurement and modelling of thermal contact resistance at a plastic metal interface, *ANTEC 1997 Conference Proceedings*, 2, 2273-2277

[19] 3M Electronic Solutions Division, Component Transport Products Catalogue, Tape & Reel Innovative Solutions for Packaging Components.

[20] Choo, H.L., Martin, P.J., and Harkin-Jones, E.M.A. (2008); Measurement of Heat Transfer for Thermoforming Simulations. *Int. J. Mater. Form Suppl* 1:1027-1030

[21] Envisiontec; <http://enviontec.com/3d-printing-materials/perfactory-materials/htm140/>, HTM140 High Temperature Molding Material

[22] Dimension1200ES, <http://www.stratasys.com/3d-printers/design-series/dimension-1200es>, ABS Mould insert