

Laboratory Stands for Wideband Analysis Radiocommunication Signals

Ryszard Studański¹, Radosław Wąs¹, Agnieszka Studańska², Jarosław Garus²

¹ Faculty of Mechanical and Electrical Engineering, Polish Naval Academy, Gdynia, Poland

² Faculty of Electronics, Telecommunications and Informatics, Gdansk University of Technology
r.studanski@amw.gdynia.pl

Abstract: A laboratory stand for wideband analysis radiocommunication signals is presented in the paper. The stand is designed for signals acquisition in wide spectrum and research a field of digital signal processing. Procedures used for simultaneous acquiring many frequency channels in selected wide band are described. The method of detection of direct sequence spread spectrum signals (DS SS) which power spectral density is lower than noise is also discussed. Executed research were performed with signals locally generated and with signals from real radio communication systems.

Key words: signal processing, wideband signals, data acquisition

Introduction

Currently produced electronic parts and circuits allow to increase the speed of signal processing. A frequency sampling of A/D converters is still growing up and it enables registering signals of wider bands or higher carrier frequencies.

A method of simultaneous acquisition of many narrowband frequency channels with one receiving set is presented in the paper. The following procedures of signal processing are described: managing of filtering, down conversion and decimation; frequency synchronization; symbol synchronization and phase synchronization. This work shows that it is possible to receive narrowband signals acquired in wideband by a receiving set. Such simultaneous registration has some advantages over the traditional separate acquisition of every frequency channel: it needs less space on a hard drive, one receiving set is needed instead of a few, information about other transmissions are not lost during the acquisition, it is much easier to examine time relations between transmissions.

Moreover such acquired signal might be used to detect the DS SS transmissions. These transmissions are usually used in military systems to hide the signal below the noise. It makes such transmissions impossible to detect by traditional methods such as using signal analyzer. The method of detection DS SS transmission with laboratory stand for wideband analysis radiocommunication signals employment is also presented.

Description of Laboratory Stand

A main aim of the laboratory stand for wideband analysis radiocommunication signals it to acquire signals in wide spectrum and then analyze them in post processing on the personal computer. It is the typical realization of software defined radio (Pereira, 2001; Faxin et al., 2006) where the main part in signal analysis and transmission receiving plays software.

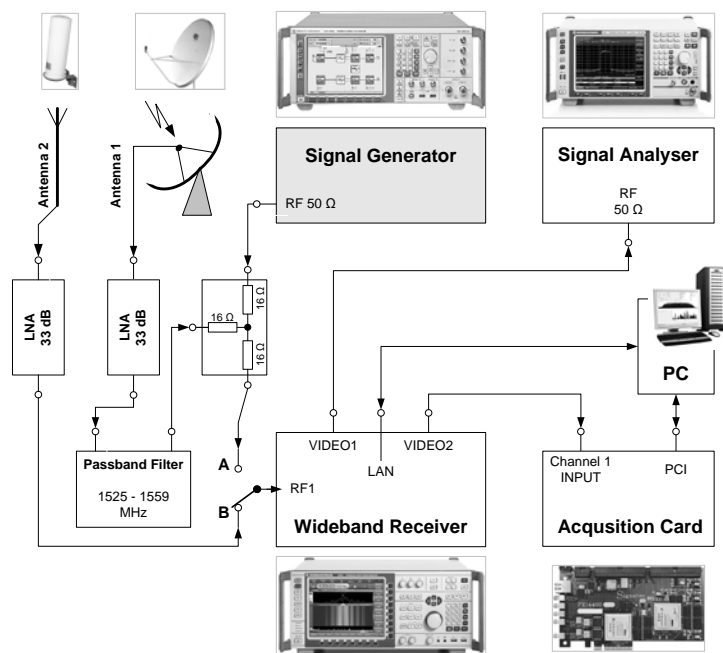

Fig. 1. The scheme of laboratory stand for wideband analysis radiocommunication signals

The laboratory stand shown in Fig. 1 consists of three parts:

- a kit of different antennas - an omnidirectional and directional antennas operating in the 0.3 - 18 GHz
- wideband receiver,
- computer with analog to digital converter (an acquisition card).

On the stand are also used following devices:

- a vector signal generator for simulation research,
- a signal combiner,
- a spectrum analyzer to control the work of receiver and acquisition card.

The omnidirectional antenna is used when acquiring signals from transmitters placed on the Earth surface, especially while the DS SS signals detection is proceeded. The satellite antenna allows to acquire signals from one of the communication satellite system. Presented stand allows to receive information transmitted in that satellite system from many frequency channels simultaneously.

The detection of DS SS signals method is vulnerable to the influence of narrowband signals. That makes essential to perform a research which helps to work out the methods of decreasing the narrowband signals influence on the reliability of detection of direct sequence spread spectrum transmissions. In this research the vector signal generator was needed as a source of the spread spectrum signal. Signals from antenna were treated as narrowband disturbances.

The vector signal generator might be used in tests and researches of procedures which enables the simultaneous information receiving from mentioned satellite system. The generator helps in providing the predictable circumstances.

The receiver allows to acquire signals in band from 100 Hz to 20 MHz. In discussed laboratory stand this receiver transforms signals from radio frequency to intermediate frequency on which the receiving or detection procedures are performed. The acquisition is usually made in 20 MHz band on intermediate frequency equal to 11 MHz. Signals from wideband receiver are delivered to the acquisition board where they are converted to digital form most often with 50 MHz sampling frequency. The role of computer is to supervise the work of wideband receiver and acquisition card. The computer also does all of the signal computing: filtering respective frequency channels, another frequency down conversion, performing receiving procedures, filtering the narrowband distortions and realizing the detection of DS SS transmission. Most of this procedures are described in the following two paragraphs.

Wideband Receiving of Satellite Communication Signals

The stand shown in Fig. 1 may be used to receive information from one of the satellite communication systems. It can be made simultaneously, because radio signals are acquired in wide spectrum. The stand allows to record almost all downlink frequency channels used in the considered system. The band of single frequency channel in this system is less then 10 kHz. The functional scheme of signal processing used to receive transmitted information is shown in Fig. 2.

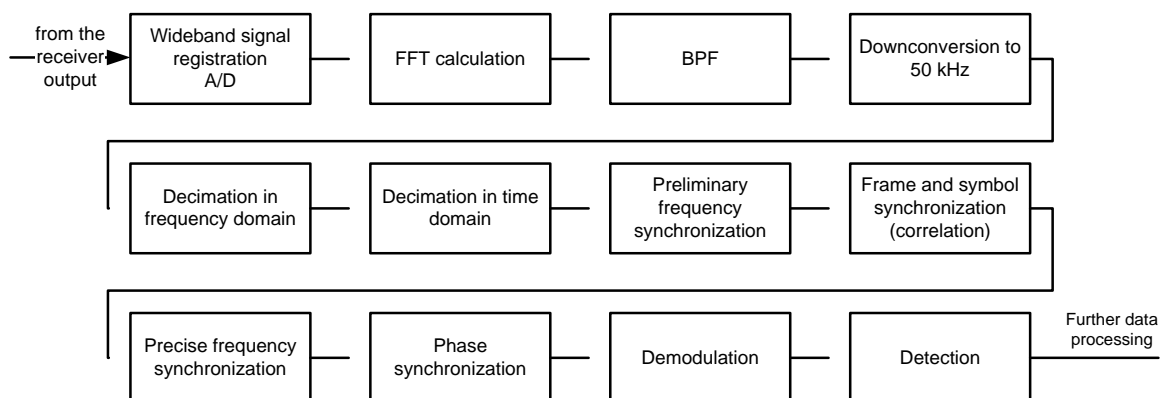

Fig. 2. Functional scheme of signal processing procedures used to receive signals

While signal registration is performed in the wideband (20 MHz) and channel band is less than 10 kHz, the first operation is a band pass filtering which suppresses the impact from other systems and channels. Moreover, to decrease frequency sampling the digital down conversion to frequency 50 kHz is required. For the frequency shifting two solutions can be implemented. In the first one, traditional frequency shifting, useful signal is combined with the signal from heterodyne to obtain the desired frequency. After this operation unwelcomed new frequency components are also generated and to suppress them another band pass filter is needed. It makes this method both time and resources consuming. The second solution uses a filter which values are 1 in the band pass and 0 beyond it which allows to carry out a frequency shifting from frequency f_1 to f_2 by changing the index of suitable spectrum components as shown in Fig. 3. The last solution has been used in the project.

After this operation the decimation is enabled. We reduce the number of samples 64 times, what changes the sampling frequency value to 781,25 kHz. This value significantly decreases the size of processed data and simultaneously keeps the gain achieved of cumulating when noise is integrated in detector. Such prepared signal is used in synchronization and demodulation operations. For demodulation, it is essential to know the exact carrier frequency of the signal, it means phase and symbol timing.

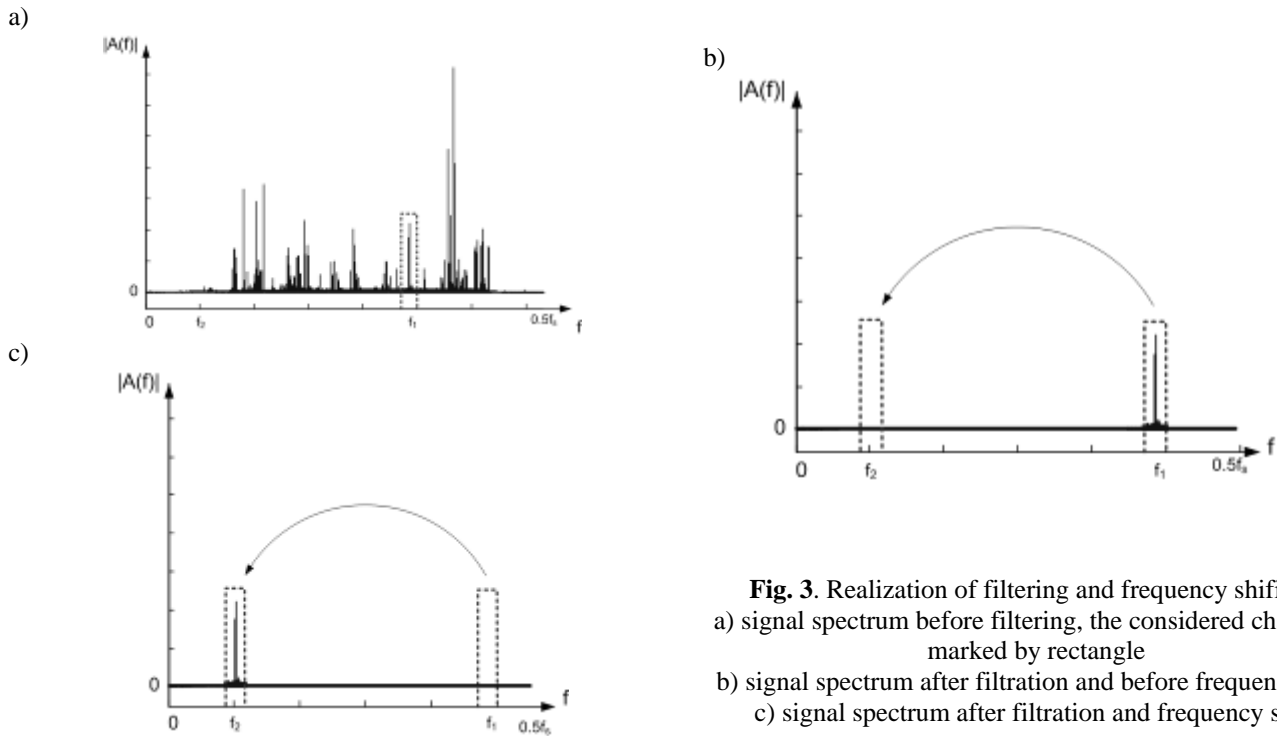

Fig. 3. Realization of filtering and frequency shifting:
 a) signal spectrum before filtering, the considered channel is marked by rectangle
 b) signal spectrum after filtration and before frequency shift
 c) signal spectrum after filtration and frequency shift

In the considered system in every frame there are bits provided for synchronization processes. These bits are especially used while finding the beginning of symbols and phase of the signal.

Because in discussed system the OQPSK modulation is used, the frequency synchronization is made by finding in the spectrum of signal raised to 4th power a component of carrier frequency $4f_c$. For example, when the OQPSK signal frequency is 50 kHz, then the component on frequency 200 kHz will be distinctive in spectrum of signal raised to the 4th power. As it is shown in Fig. 2, after decimation the preliminary frequency synchronization is performed. For the correlation part we need to know only approximately the signal frequency. It is managed by computing the spectrum of signal raised to 4th power from fewer of number samples then when signal frequency is computed precisely. When the frequency signal is known, the model of signal is prepared for correlation. The unique word modulates the carrier which frequency is equal to the found one. Then the signal model is correlated with acquired signal to find the symbol and frame synchronization. If the signal is found the precise frequency synchronization is performed. In the end the phase synchronization must be achieved. It is accomplished because the unique word is known. As we know what symbols to expect, we can compute the difference between the angle of predicted point in the constellation diagram and the point achieved by demodulating signal without phase synchronization. The difference between these angles is the phase correction which should be taken in account during actual demodulation. When all signals parameters are known the demodulation processes can be performed.

The DS SS Signals Detection

The method of the DS SS signals detection is based on rising the value of signal samples to the power of n , where n depends on the type of used digital angle modulation. In spectrum of raised signal in $n \cdot f_n$ appears a sufficiently large value, where f_n is a frequency of discussed signal.

If the input signal is squared, then in accordance with trigonometric relationship:

$$\cos^2 \alpha = \frac{\cos 2\alpha + 1}{2} \tag{1}$$

the appearance of a spectrum component at frequency two times higher than the signal carrier frequency can be observed (Was et al, 2008.; Katulski et al, 2008). The scheme of signal processing is presented in the Fig. 4.

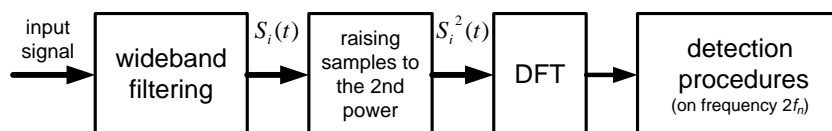

Fig. 4. The simplified scheme of signal processing used to detect of DS SS transmissions with BPSK modulation

An experiment was performed to detect the wideband transmission of the DS SS with BPSK modulation with negative SNR values, carried out in the vicinity of real and relatively strong signals which is narrowband interference for the detection algorithms. Results for procedures performed with an inactive and active block for detection and elimination of narrowband signals are presented below.

The aim of the experiment was to explore the possibilities of the DS SS signal with BPSK modulation detection in the presence of the real signals. The satellite signals received in the frequency range 1525 MHz to 1560 MHz were used as the background. The range of frequency band was chosen in such a way that there was relatively strong narrowband interference in the vicinity of the sought signal. The ratio of the maximum levels of the carrier power to the level of noise ranged from 10 to 20 dB (see Fig. 5a). The parameters of generated the DS SS signal with BPSK modulation were selected in such a way to get a negative ratio of wanted signal to the noise power $SNR = -10$ dB at the input of the acquisition card. The frequency range covered by the presence of the wideband direct-scattering spectrum indicated in Fig. 5a and Fig. 6a in a shaded box ($B_{DS} = 2.44$ MHz, $f_n = 21.4$ MHz on the IF). The results of the experiment in the form of spectrum power density characteristics of the analyzed signal bandwidth and signal PSD of squared signal samples (in terms of twice the frequency) is shown in Fig. 5b and 6b. In the presented spectral characteristics the FFT of size $N = 2^{14}$ was used.

Analyzing obtained results, it can be concluded that when the narrowband signals have not been subjected to elimination (see Fig. 5b), the detection condition has been met for the six components of the spectrum. As it can be seen, none of the components exceeding the detection threshold does not come from the DS SS signal hidden in noise. Moreover, in the middle of the band appeared some unwelcome "false" components indicating the possibility of hidden signals in noise. These components are the products of intermodulation, arising from the squaring of signal samples.

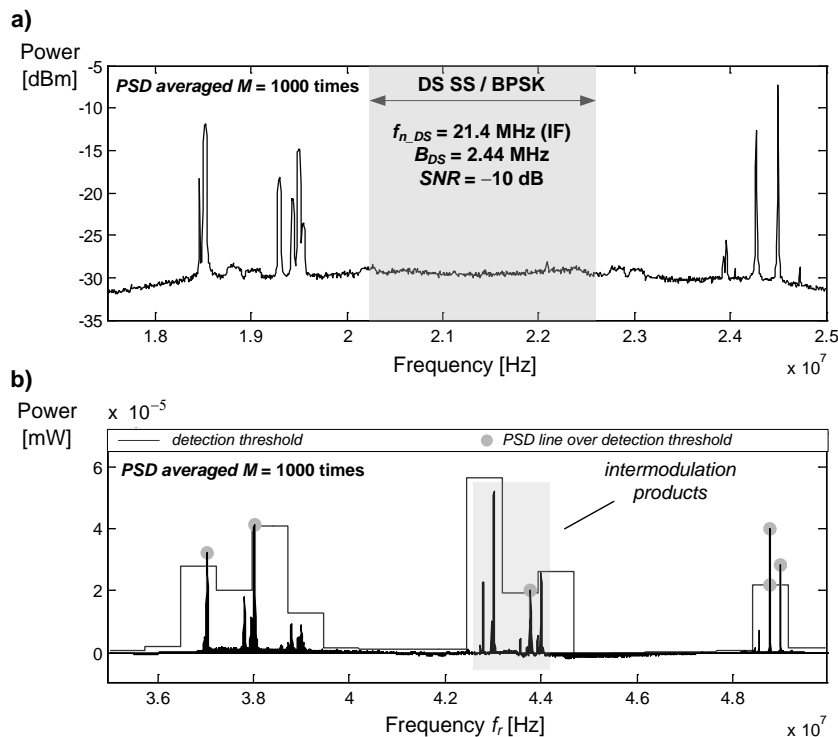

Fig. 5. Demonstration of PSD for signal samples on the input of the acquisition card (a) and results of the DS SS transmission in the absence of procedures for the elimination of narrowband signals

To sum up the carried out experiments, it can be concluded that the detection process has been disturbed by narrowband signals, and the obtained results give an erroneous impression of the existence, in the analyzed band, the wideband DS SS signals with negative SNR values. Therefore, detection procedures were repeated on the same set of samples, but this time with the active block for detection and elimination of narrowband signals. As a result of implementation of appropriate procedures six narrow-band signals were detected and eliminated. The PSD which figure in the band analysis is presented in Fig. 4a. Such a prepared signal was processed in accordance with the signal detection algorithm for the DS SS transmission with BPSK modulation using the spectral analysis of the squared samples put in the time domain. A result in a graphic form and the selected detection threshold is shown in Figure 6b. The experiment RF center frequency for input circuits of the receiver corresponded to the carrier frequency of generated spread spectrum signal, which in turn should lead to the emergence of P_h component (harmonic coming from searching for DS SS signal) on the frequency 42.8 MHz, exactly twice the IF carrier of 21.4 MHz.

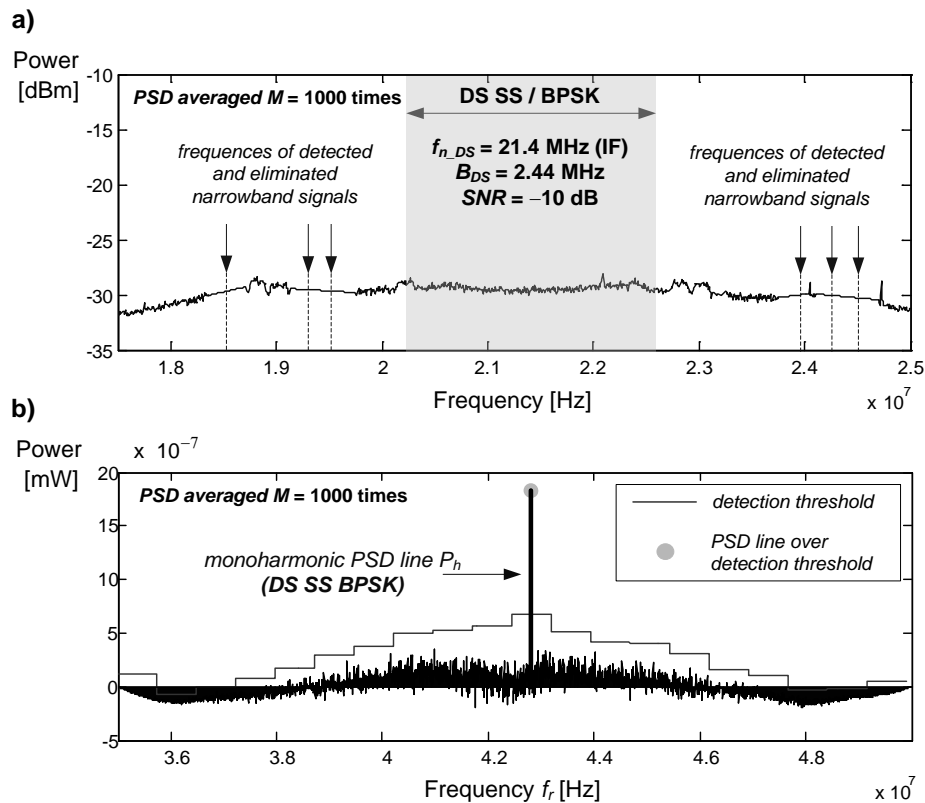

Fig. 6. PSD of the signal of fig. 5a after the elimination of narrowband signals (a) and the results of the procedures for detecting the DS SS transmission with BPSK modulation (b)

Proposed procedures of detection DS SS signals were used to detect the GPS signals (for more details see Studanski et al., 2011).

Conclusion

The development of electronic parts and computational components enables to use digital signal processing in wider variety of applications. Therefore, the thorough technical analysis of registered signal is possible.

It is manageable to receive narrowband signals from a real radio satellite system acquired in the wideband. Such approach enables to register signals from many frequency channels and store them on a hard drive.

The conducted experiments have confirmed the effectiveness of signal processing methods developed for the detection of the DS SS transmission with BPSK modulation and the power of signal lower than noise power. Using the method for testing the squared signal PSD, it is imperative to carry out the elimination of narrowband signals present in the analysis. Unwanted narrowband signals can disturb the proper operation of the detection algorithms by generating ambiguous and "fake" results.

Acknowledgement

This scientific work is financed from the funds for science in the years 2009-2011 as a development project.

References

- Pereira J. M. (2001): *Reconfigurable Radio: the evolving perspectives of different players*. Personal, Indoor and Mobile Radio Communications, 2001 12th IEEE International Symposium, pp. C-79 – C-84 vol. 1.
- Faxin Yu, Xiaojun Jin, Zhaoging Liu (2006): *Parallel Processing Design of Multi-channel LIF Digital Receiver*. Radar, 2006. CIE'06. International Conference, pp. 1-4.
- Was R., Katulski R. J., Stefanski J., Studanski R. (2008): *DS CDMA radio transmissions detection*, IEEE Conference on Technologies for Homeland Security, Boston, MA. 2008, pp.34-40.
- Katulski R., Studanska A., Stefanski J., Studanski R., Was R. (2008): *Influence of Narrowband Interferences on DS CDMA Signals Detection*. Proceedings of the 18th International Conference, Electromagnetic Disturbance EMD'2008", pp. 57-62,
- Studanski R., Was R., Studanska A., (2011): *Detection of the Direct Sequence Spread Spectrum Signals with BPSK Modulation*. Polish Journal of Environmental Studies, Olsztyn Vol. 20; No 5A; pp. 148-151.