

Voltage Type First Order All-Pass Filter Employing Fully Differential Current Feedback Operational Amplifier and Quadrature Oscillator

Mahmut ÜN*, Fırat KAÇAR**

*Elect-Communication Eng. Dept, Faculty of Eng.-Arch., Beykent University
Ayazağa, Şişli, İstanbul, TURKEY, e-mail: umahmut@beykent.edu.tr

**Elect.-Electronic Eng. Dept. Faculty of Eng., İstanbul University, 34320
Avcılar, İstanbul, TURKEY, e-mail: fkacar@istanbul.edu.tr

Alınış: 10 Temmuz 2007

Kabul Ediliş: 14 Kasım 2007

Abstract: An improvement voltage mode first order all-pass filter configuration is proposed. The presented circuit uses a single fully differential current feedback operational amplifier (FDCFOA), resistors and a grounded capacitor. High input impedance of the proposed filter enables the circuit to be cascaded without additional buffers. It does not impose any component matching constraint in analog signal processing circuits. Also higher order all-pass filter could be achieved by cascading the proposed all-pass sections. In order to demonstrate the performance of the proposed filter a new voltage mode oscillator is introduced as an application example. Furthermore the theoretical results are verified with SPICE simulations using a CMOS realization of FDCFOA.

Key words: All-pass filter, fully differential current feedback operational amplifier, analog integrated circuits, quadrature oscillator.

Özet: Gerilim modunda birinci dereceden tüm geçiren yeni bir süzgeç devresi önerilmiştir. Önerilen devrede bir tam diferansiyel akım geribeslemeli işlemsel kuvvetlendirici, dirençler ve topraklı bir kapasite bulunmaktadır. Önerilen devrenin yüksek giriş direnci, ek tampon kullanılmadan devrenin kaskad bağlanabilmesini sağlamaktadır. Analog işaret işleme devrelerinde herhangi bir eleman denkleştirme koşuluna gerek duyulmamaktadır. Aynı zamanda daha yüksek dereceden tüm geçiren süzgeçler önerilen birinci dereceden süzgeçler kaskad bağlanarak elde edilebilmektedir. Önerilen süzgecin başarımını göstermek amacıyla, bir uygulama örneği olarak gerilim modunda yeni bir osilatör tanıtılmıştır. Bundan başka teorik sonuçlar, FDCFOA elemanının CMOS gerçekleştirilmesi kullanılarak SPICE benzetimleriyle doğrulanmıştır.

Anahtar Kelimeler: Tüm geçiren süzgeç, tam farksal akım geribeslemeli işlemsel kuvvetlendirici, analog tümdevreler, quadrature osilatör

Introduction

All-pass filters are one of the most important building block of many analog signal processing applications and therefore have received much attention. They are generally used for introducing a frequency dependent delay while keeping the amplitude of the input signal constant over the desired frequency range. Other type of the active circuits such as oscillators and high-Q band-pass filters are also realized by using all-pass filters [1-6]. The active devices that have been used for the realizations of first order all-pass circuits include operational amplifiers (OP-AMP), second generation current conveyor (CCII), current feedback op-amps (CFOA), operational transconductance amplifier (OTA) and four terminal floating nullor (FTFN). Several voltage and current mode first order all-pass filters are available in the literature [2-10]. A literature survey shows that there are only a few transadmittance mode filters. Since the introduction of FDCFOA by Soliman, a few applications have appeared in the literature [10-12]. The FDCFOA has the advantages of the single ended CFOA beside the advantages of the fully differential signal processing. The FDCFOA has many useful applications like the single ended CFOA [3–12]. The main purpose of these paper is to propose a new application of FDCFOA as a voltage mode first and higher order all-pass filter. The all-pass filters can be also used to synthesize multiphase oscillators and second-order band-pass filters.

The paper is organized as follows, in Section 2, the proposed of the all-pass filter FDCFOA is presented. In Section 3, FDCFOA-based voltage mode first order allpass filter configuration is proposed and also a sinusoidal oscillator is implemented to show the usefulness of the proposed configuration as an illustrating example. In Section 4, To verify the theoretical study the first order all-pass filter was constructed and simulated with PSPICE program. PSpice simulations of the proposed FDCFOA and its applications using CMOS 0.35 μm technology are also given.

The Proposed All-Pass Filter Circuit

The FDCFOA is basically a fully differential device as shown in Figure 1. The Y_1 and Y_2 terminals are high impedance terminals while X_1 and X_2 terminals are low impedance ones. The differential input voltage V_{Y12} applied across Y_1 and Y_2 terminals is conveyed to differential voltage across the X_1 and X_2 terminals; i.e., ($V_{X12} = V_{Y12}$). The input currents applied to the X_1 and X_2 are conveyed to the Z_1 and Z_2 terminals are high impedance output nodes suitable for current outputs. The differential voltage developed across the Z_1 and Z_2 terminals are buffered by a unity gain fully differential voltage buffer to the output terminals O_1 and O_2 , i.e., ($V_{O12} = V_{Z12}$).

The port relations at an ideal FDCFOA, shown in Figure 1a. can be given by

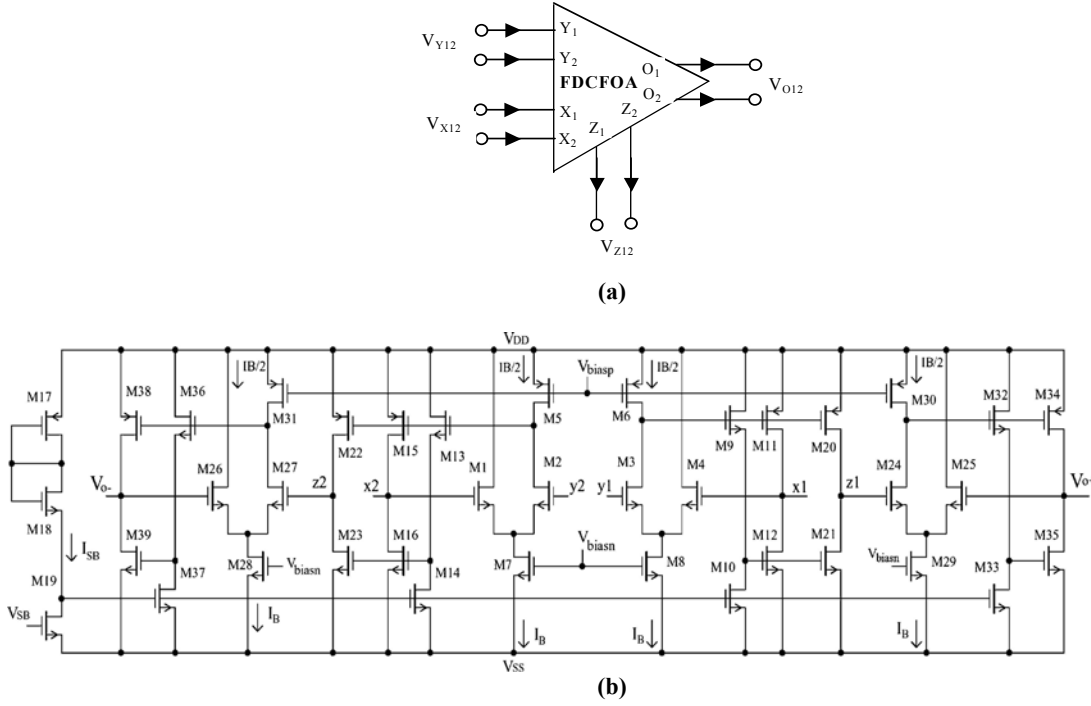

Figure 1: a) The Symbol of the FDCFOA b) The CMOS circuit of the FDCFOA

$$\begin{bmatrix} V_{Y12} \\ I_{Z1} \\ I_{Z2} \\ V_{I2} \end{bmatrix} = \begin{bmatrix} 1 & 0 & 0 & 0 \\ 0 & 1 & 0 & 0 \\ 0 & 0 & 1 & 0 \\ 0 & 0 & 0 & 1 \end{bmatrix} \begin{bmatrix} V_{X12} \\ I_{X1} \\ I_{X2} \\ V_{Z12} \end{bmatrix} \quad (1)$$

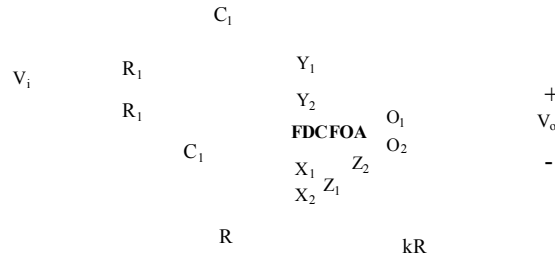

Figure 2: The proposed voltage mode first order all-pass filter configuration

The proposed configuration is shown in Figure 2. Routine analysis yields the voltage mode transfer function as follows

$$\frac{V_o}{V_i} = (k) \frac{-1 + R_1 C_1 s}{1 + R_1 C_1 s} \quad (2)$$

This transfer function allows the designer both inverting and noninverting types of first order voltage mode all-pass filters by exchanging \$C_1\$ and \$R_1\$ using only a single FDCFOA. Thus both inverting and noninverting types of first order voltage mode all-pass filters are realized using only a single FDCFOA, resistors and a grounded capacitor without imposing any passive element condition. Furthermore transfer function analysis of the proposed all-pass filter can be made for the nonideal FDCFOA by following the same procedure gives for the ideal case.

Quadrature Oscillator As An All-Pass Filter Application

It is well-known fact that a sinusoidal oscillator can be realized using an all-pass filter and an integrator [13] as shown in Figure 3.

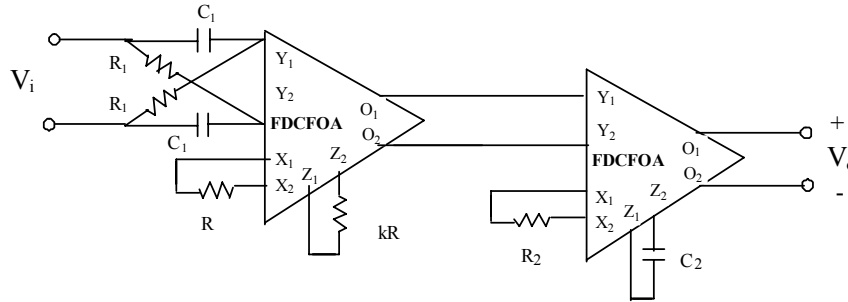

Figure 3: FDCFOA-based sinusoidal oscillator circuit

In this circuit, the proposed allpass filter and a voltage mode integrator employing a FDCFOA with two matched resistors and capacitors are used. For providing a sinusoidal oscillation the loop gain of the circuit is set the unity at $s=j\omega$, i. e

$$(k) \left[\frac{s-1/R_1C_1}{s+1/R_1C_1} \right] \left[-\frac{1}{sR_2C_2} \right]_{s=j\omega} = 1 \quad (3)$$

From Eq. (3) oscillation condition and frequency can be found respectively as

$$(k) R_1C_1 = R_2C_2 \quad (4)$$

$$\omega_o = \left(\frac{1}{R_1C_1} \right) \quad (5)$$

For simplicity, if we choose $R_1 = R_2 = R$ and $C_1 = C_2 = C$, oscillation condition is satisfied and oscillation frequency becomes

$$\omega_o = \frac{1}{RC} \quad (6)$$

Also oscillator condition and frequency can be calculated in terms of nonideality parameters of FDCFOA for the nonideal FDCFOA. It is assumed that all FDCFOAs are ideal for all transfer function analysis given above.

Simulation Results

The performance of the proposed FDCFOA circuit was verified by performing PSpice simulations with supply voltages ± 1.5 V and using $0.35 \mu\text{m}$ CMOS technology parameters. The aspect ratios of the transistors are given in Table 1. To verify the theoretical study the first order all-pass filter was constructed and simulated with PSPICE program. For this purpose, passive components were chosen as $R=10\text{k}\Omega$, $R_1=10\text{k}\Omega$ and $C=1\text{pF}$, which results in 1.59MHz center frequency. Since there is no any commercial implementation of the FDCFOA, the SPICE simulations were performed using a CMOS realization of FDCFOA [12]. Simulated magnitude and phase responses of the filter are given in Figure 4. Actually, the parasitic resistance and capacitances of CMOS-FDCFOA, that is not mentioned in the limited space available here, causes the deviations in the frequency and phase response of the filter from theoretical values. For either discrete or integrated implementation of the filter circuit, the designers should pay much attention to reduce the parasitics of FDCFOA. Furthermore, sinusoidal input-output waveforms of allpass filter is presented in Figure 5 for the component values given above. Oscillator employing the proposed allpass filter has also been simulated using PSPICE. In this simulation, $k=2$, all resistances and capacitances were taken as $10\text{k}\Omega$ and 10pF respectively which results in a 1.59 MHz oscillation frequency. The output waveforms of the oscillator are shown in Figure 6. Because of the parasitic effects of the FDCFOAs some deformations are observed in the output waveforms of the filter and oscillator.

Table 1. Transistors aspect ratios for the circuit shown in Figure 1a

Transistors	W (μm)	L (μm)
M ₁ -M ₈	0.7	5.6
M ₈ -M ₁₆	0.7	0.7
M ₁₇ -M ₁₉ , M ₃₇	14	0.7
M ₂₀ , M ₃₈	17.5	0.7
M ₂₁ -M ₃₉	35	0.7
M ₂₂ , M ₂₆ , M ₂₉ , M ₃₃ , M ₃₅	70	0.7
M ₂₃ , M ₂₈ , M ₃₀ , M ₃₄ , M ₃₆	35	0.7
M ₂₄	1.4	0.7
M ₂₅ , M ₂₇ , M ₃₁ , M ₃₂	1.4	0.7

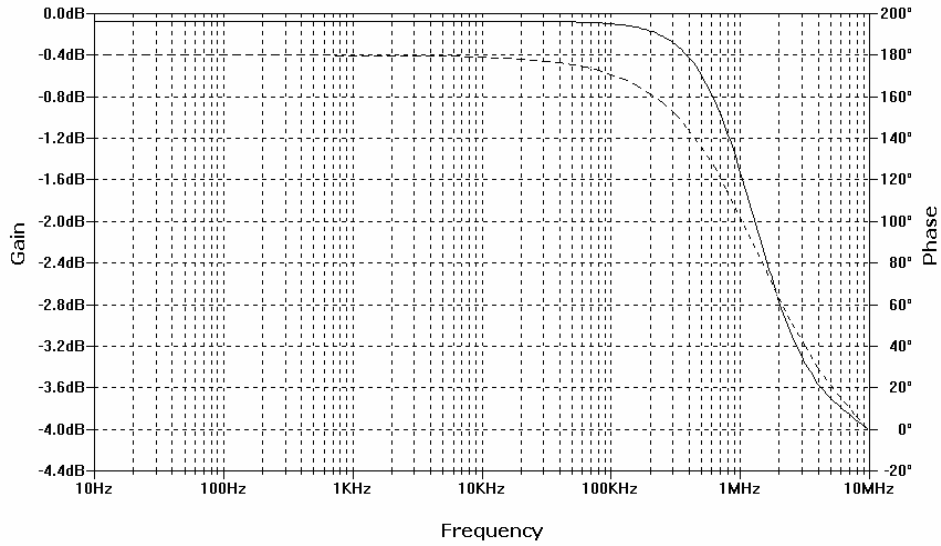

Figure 4: PSPICE simulation result of the proposed voltage-mode first-order allpass filter (Gain:—, Phase :----)

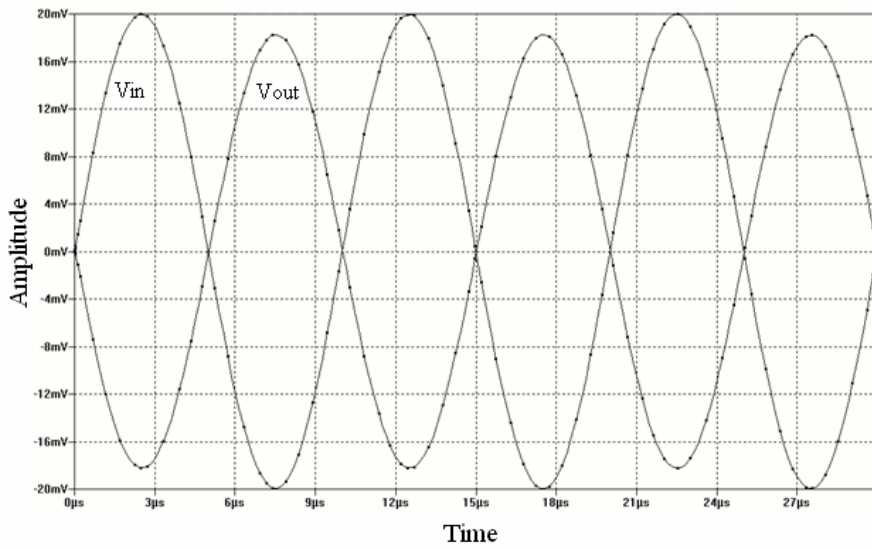

Figure 5: Simulated output waveforms of the All-pass filter (Input:■ Output:▲)

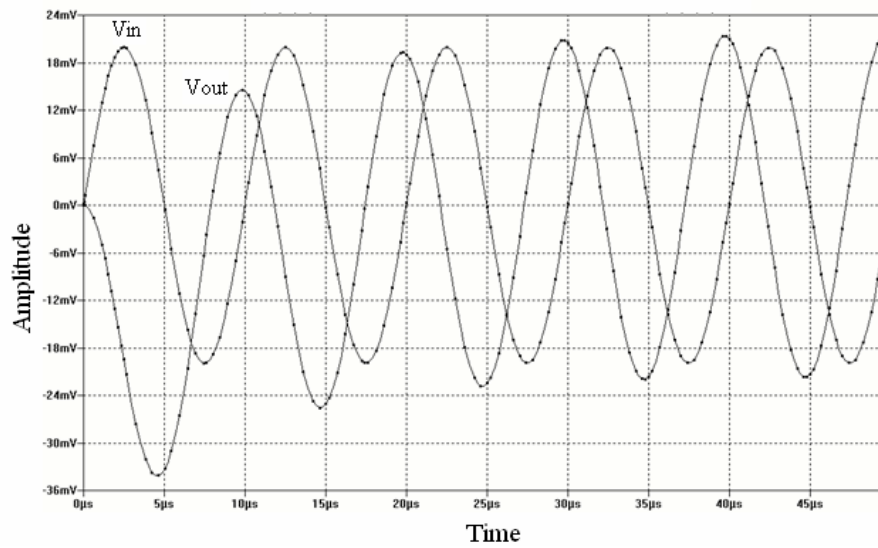

Figure 6: Simulated output waveforms of the Quadrature oscillator (Input:■ Output:▲)

Conclusion

A voltage mode first order all-pass filter configuration is presented. The proposed circuit uses only a single FDCFOA, resistors and capacitors. The output of the filter exhibits low output impedance so that the synthesized filter can be cascaded without additional buffers. The proposed circuit uses grounded capacitor and resistors which simplifies integrated circuit implementation. Higher order all-pass filter could be achieved by cascading the proposed all-pass section since filter sections have high input and low output impedance. As an application of the filter, a new quadrature oscillator was realized. SPICE simulations were performed by using a fully differential CMOS-CFOA. PSPICE simulation results of the filter response are in good agreement with the predicted theory. It also provides an alternative solution to the realization of phase equalizer for analog signal processing applications. It is supposed that all FDCFOAs used in the proposed circuits analyzed in the paper are ideal. Analysis of the effects of tracking error parameters of FDCFOA on the proposed circuits are considered for the another studies.

References

- [1] Schauman, R., Valkenburg E., Design of analog filters. Oxford University Press, New York, 2001.
- [2] Donald, T. C., David, T. C., Jason, R. G., A high frequency integrable band-pass filter configuration, IEEE Transactions on Circuits and Systems, 44 (1997) 856-860.
- [3] Cicekoglu, O., Kuntman, H., Berk, S., Single CCII+ based all-pass filters, Int. J. of Electronics, 86 (1999), 947-959.
- [4] Çam, U., Cicekoglu, O., Gülsoy, M., Kuntman, H., New voltage and current mode first-order all-pass filters using single FTFN, Frequenz, 7-8 (2000), 177-179.
- [5] Higashimura M., Fukai, Y., Realization of all-pass and notch filters using a single current conveyor, Int. J. of Electronics, 65 (1988), 823-828.
- [6] Toker, A., Ozoguz, S., Cicekoglu, O., Acar, C., Current mode all-pass filters using current differencing buffered amplifier and new high-Q band-pass filter configuration, IEEE Transaction on Circuits and Systems-II, 47 (2000), 949-954.
- [7] Sudhanshu, S., Iqbal, A.K., Novel first order allpass section using single CCIII, Int. J. Electronics, 88 (2001), 773-778.
- [8] Çam, U., A new transadmittance type first order allpass filter employing single third generation current conveyor, Analog Integ. Circuits and Signal Proces., 43 (2005), 97-99.
- [9] Wang, H. Y., Lee, C. T., Systematic synthesis R-L and C-D immitances using single CCIII, Electronic Letters, 88 (2000), 293-294.
- [10] Minai ,S., A new high performance CMOS third generation current conveyor (CCIII) and its application, Electrical Engineering, 85 (2003), 147-153.
- [11] Toker, A., Cicekoglu, O., Özcan, S., Kuntman, H., High output impedance transadmittance type continuous-time multifunction filter with minimum active elements, International Journal of Electronics, 88 (2001), 1085-1091.
- [12] Soliman A. M., Awad, I. A., Fully differential CMOS current feedback operational amplifier, Analog Integ. Circuits and Signal Processing, 43 (2005), 61-62.
- [13] Haritantis, I., General method for designing RC harmonic oscillators, International Journal of Electronics, 58 (1985), 295-305.