



## FEM SIMULATION STUDY FOR A WELD SEAM DEFECT OF AN EXTRUDED PROFILE

Önder AYER<sup>1\*</sup> , İsmail KARAKAYA<sup>2</sup> 

<sup>1</sup>Trakya University, Department of Mechanical Engineering, Edirne, TURKEY

<sup>2</sup>eksenAL Aluminum Extrusion Die Factory, Istanbul, TURKEY

### Cite this article as:

Ayer, Ö., Karakaya, İ. (2021). FEM simulation study for a weld seam defect of an extruded profile, *Trakya University Journal of Engineering Sciences*.

### Highlights

- Finite element methods (FEM) give satisfactory and reliable results for complicated engineering problems.
- Extrusion defects could be predicted by using FEM-based software.
- FEM supported die design reduces both the total production cost and extrusion correction time.

### Article Info

#### Article History:

Received:  
December 29, 2021

Accepted:  
January 5, 2022

#### Keywords:

Porthole Extrusion Die Design;  
Weld Seam Formation;  
Aluminium Extrusion;  
Finite Element Method.

### Abstract

Aluminum material is an engineering material that is increasingly expanding its usage area today, thanks to its resistance to corrosion, strength and lightness. Various problems are encountered in the aluminum extrusion process. In the study, the predictability of weld seam formation defect during the design phase was investigated. By determining the process parameters, the weld seam lines in the product was investigated with the FEM-based HyperXtrude, and the real surface appearances of the product were compared with the FEM results. The results of the study provide satisfactory predictions for the porthole die design.

## 1. Introduction

Aluminum is an engineering material that is used in significant amounts thanks to its color, electrical conductivity, resistance to corrosion, strength, and lightness. Aluminum can be shaped by various methods such as casting, forging, and extrusion. (Lu et al., 2016) The hot extrusion method is the most common method used to produce profiles of different cross-sections and wall thicknesses from aluminum. (Edwards et al., 2009; Liu et al., 2018; Negendank et al., 2020; Vazdirvanidis et al., 2019) Especially, with the development of the industry, porthole dies are used to obtain profiles with large cross-section, various multi-cavities, and variable wall thicknesses. Porthole die design is of great importance to provide the optimum material flow, homogeneous temperature distribution and to reduce the amount of scrap for desired profile. (Liu et al., 2018) Such a die gives complex hollow sections to be extruded by splitting a billet into various metal steams that are rejoined inside to form longitudinal weld seams in the solid-state. (Edwards et al., 2009; Yu and Zhao, 2018). Well bonded weld seams are crucial when extruding hollow sections for load-bearing applications. (Yu et al., 2019, 2017) The design of a porthole die is directly related to the designer's talent and experience, trial and repair sequence and understanding the relationship between die structure and material flow. (Dong et al., 2016) That design procedure consumes so much time and energy and hence the computation methods and FEM-based software are getting attention both for reducing the total time and cycle and prediction of extrusion defects. Welding defect occurs for hollow sections and criteria for welding quality predictions are of great importance with the aim to optimize the die geometry design and extrusion parameters. (Fan et al., 2017) It is an undesirable extrusion defect since it causes structural damage when requiring mechanical strength.

In this study, FEM-based software HyperXtrude was used to simulate extrusion process and aimed to predict possible extrusion defect especially observing welding problem for an extruded profile. Weld seam formation is a complex problem for extrusion process and related with material properties, alloy composition, microstructure, process temperature and velocity. Therefore, it is not easy to predict the problem but HyperXtrude gives satisfactory estimations and accurate predictions for possible defects. The designer presents optimum die design by reading the FEM results.

## 2. Material and Methods

Four porthole extrusion die were used in the study. The portholes distribute the material flow balanced and provide an equal flow to the welding chamber. The porthole die setup was designed with SolidWorks software and then the 3D model was imported to the HyperXtrude software which is unique for extrusion analysis. The die setup was given in Figure 1. The process was simulated with FEM software for the strain, velocity, grain size distribution, and weld surface analysis.

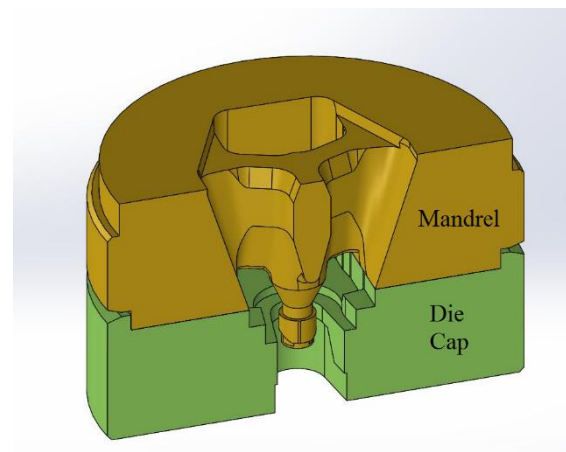

**Figure 1.** Die Setup

The simulation for the proposed model was carried out with a workstation with two Intel Xeon CPU (E5645)-2.40 GHz processors. The process parameters were selected as it is used in the extrusion

process. The process temperature was 460 °C, the punch velocity is 5 mm/sec, analysis type is direct, mesh size is selected as fine and mesh number is about 960,000. The analysis type is steady. The material was selected as AA6063. The selected profile has variable wall thickness and complex cross-section.

### 3. Results & Discussions

The Fem analysis was carried out to obtain a final profile of the extrusion product and predict whether there is a possible extrusion defect. For this purpose, the Fem model was results were analyzed. The strain distribution was given in Figure 2. It can be seen from the figure that higher deformation zone is on outer of profile. The higher deformation gives the higher strain values. Maximum strain value reaches 93.82 while the minimum was 1.24. The result clearly shows that the profile was divided into two different deformation zone. In the middle of the surface, a welding problem could be observed.

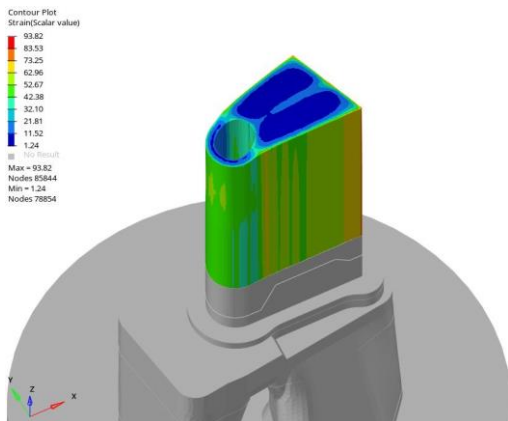

**Figure 2.** The strain distribution

FEM result for weld surface was given in Figure 3. It is clearly observed that weld seam formation is located in the middle of the profile. The results are coherent with the strain distribution of the profile. The red region which value is around 6 provides the possible weld seam formation in the profile. It validates that weld seam formation may occur at the

center of the profile.

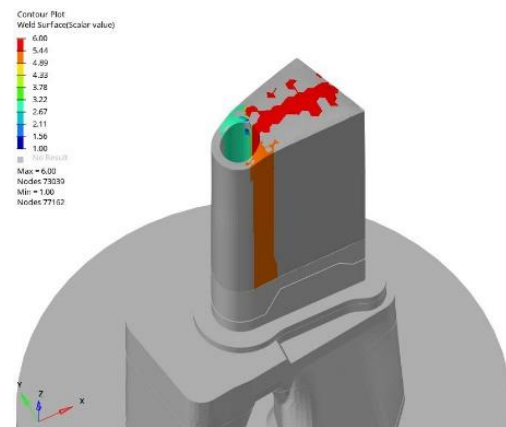

**Figure 3.** Weld Surface of the profile.

Figure 4 shows the exit velocity distribution for desired profile. Exit velocity is an important parameter for the quality of the product, especially investigating the extrusion defects. Punch velocity is selected as 5 mm/sec for the process and exit velocity value of the product reaches the 103-113 mm/sec range. It can be clearly seen from the figure that the velocity distribution is not homogenous hence it may cause extrusion defect. The die design should be reconsidered by taking this into account.

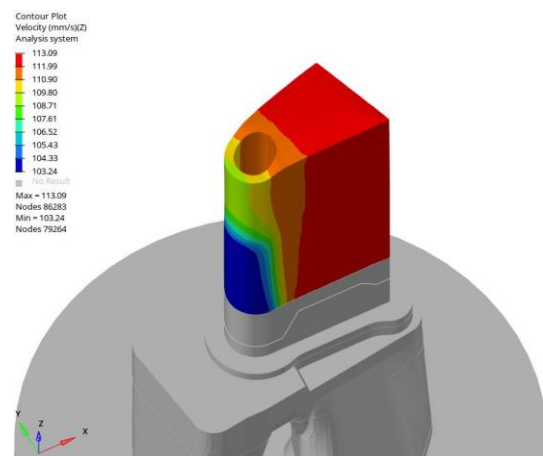

**Figure 4.** Exit velocity distribution of the product

In the Figure 5, the extruded profile could be seen. Weld seam formation could be observed on the surface by naked eye. The weld seam lines are so distinct and almost compatible with the FEM results.

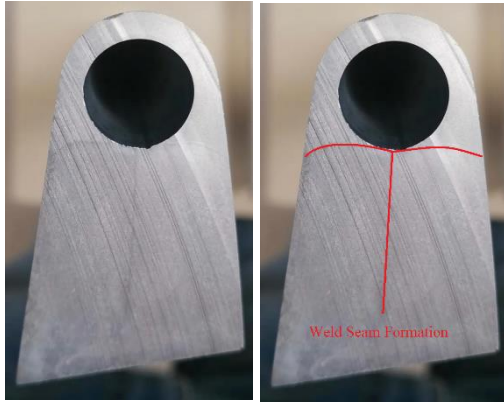

**Figure 5.** Extruded profile and weld seam formation

#### 4. Conclusions

The study was aimed to predict weld seam formation for the direct extrusion with porthole die. It is concluded from the results that selected process parameters to cause the weld seam lines on the product. Hence, the die should be redesigned to obtain defect-free products. The strain is the key parameter for estimating the weld seams. Additionally, HyperXtrude software makes predictions for the weld seam formation zones and generally gives useful information to the designers. In this study, FEM results predicted the weld seam formation on the product. It can be concluded that the FEM is a useful tool for die design and reduces cost, time, and energy. The study could be extended to redesign the die set up and extrude profile.

#### References

- Dong, Y., Zhang, C., Luo, W., Yang, S., Zhao, G., (2016). Material flow analysis and extrusion die modifications for an irregular and multitooth aluminum alloy radiator. *Int. J. Adv. Manuf. Technology*, 85. 1927–1935.
- Edwards, S.P., Den Bakker, A.J., Zhou, J., Katgerman, L., (2009). Physical simulation of longitudinal weld seam formation during extrusion to produce hollow aluminum profiles. *Mater. Manuf. Process*. 24. 409–421.
- Fan, X., Chen, L., Chen, G., Zhao, G., Zhang, C., (2017). Joining of 1060/6063 aluminum alloys based on porthole die extrusion process. *J. Mater. Process. Technol.* 250. 65–72.
- Liu, Z., Li, L., Li, S., Yi, J., Wang, G., (2018). Simulation analysis of porthole die extrusion process and die structure modifications for an aluminum profile with high length-width ratio and small cavity. *Materials (Basel)*. 11. 1-20.
- Lu, X., Zhang, C., Zhao, G., Guan, Y., Chen, L., Gao, A., (2016). State-of-the-art of extrusion welding and proposal of a method to evaluate quantitatively welding quality during three-dimensional extrusion process. *Mater. Des.* 89. 737–748.
- Negendank, M., Sanabria, V., Reimers, W., Mueller, S., (2020). Numerical and experimental evaluation of an alternative mechanism for wall thickness variations of hollow profiles applying a porthole die. *Procedia Manuf.* 50. 79–85.
- Vazdirvanidis, A., Pressas, I., Papadopoulou, S., Toulfatzis, A., Rikos, A., Katsivarda, M., Symeonidis, G., Pantazopoulos, G., (2019). Examination of formability properties of 6063 alloy extruded profiles for the automotive industry. *Metals (Basel)*. 9. 1–25.
- Yu, J., Zhao, G., (2018). Interfacial structure and bonding mechanism of weld seams during porthole die extrusion of aluminum alloy profiles. *Mater. Charact.* 138. 56–66.
- Yu, J., Zhao, G., Cui, W., Chen, L., Chen, X., (2019). Evaluating the welding quality of longitudinal welds in a hollow profile manufactured by porthole die extrusion: Experiments and simulation. *J. Manuf. Process.* 38. 502–515.
- Yu, J., Zhao, G., Cui, W., Zhang, C., Chen, L., (2017). Microstructural evolution and mechanical properties of welding seams in aluminum alloy profiles extruded by a porthole die under different billet heating temperatures and extrusion speeds. *J. Mater. Process. Technol.* 247. 214–222.