

MATHEMATICAL ANALYSIS OF WARP ELONGATION IN WEAVING MACHINES WITH POSITIVE BACKREST SYSTEM

POZİTİF ARKA KÖPRÜ SİSTEMLİ DOKUMA MAKİNELERİNDE ÇÖZGÜ UZAMASININ MATEMATİKSEL ANALİZİ

Özge ÇELİK, Recep EREN

Uludag University, Department of Textile Engineering, Bursa, Turkey

Received: 17.04.2013

Accepted: 14.11.2013

ABSTRACT

In this paper, a mathematical analysis of warp elongation is carried out in weaving machines with positive backrest system. The influence of backrest swinging angle, shed closing angle, backrest orientation angle and backrest phase difference on warp elongation is investigated. This study is done for symmetrical shed and heddle motion both with and without dwell. Both backrest and heddle mechanisms are assumed to have simple harmonic motion curves. Results have shown that especially shed closing angle and backrest phase difference have an important effect on warp elongation curve over a loom revolution. As a result, it can be concluded that the requirements of weaving of different type of fabrics and loom settings cannot be met by a motion curve obtained by crank rocker or cam mechanism with positive backrest mechanisms. By producing different motion curves with motor driven positive backrest, optimum warp elongation or warp tension curves can be obtained for weaving of different type of fabrics.

Key Words: Weaving, Backrest, Positive backrest, Warp elongation, Warp tension.

ÖZET

Bu makalede, pozitif arka köprü sistemine sahip dokuma makinelerinde çözgü uzamasının matematiksel analizi yapılmıştır. Arka köprü salınım açısı, ağızlık kapanma açısı, arka köprü eğiklik açısı ve arka köprü faz farkının çözgü uzaması üzerine etkisi araştırılmıştır. Araştırma, simetrik ağızlık ve hem beklemeli hem de beklemesiz çerçeve hareketleri için gerçekleştirilmiştir. Hem çerçeve hem de arka köprü hareketinin basit harmonik hareket eğrisine göre gerçekleştiği kabul edilerek yapılan araştırmada, özellikle ağızlık kapanma açısı ve arka köprü faz farkının bir tezgah devrindeki çözgü uzama eğrisi üzerinde önemli bir etkiye sahip olduğu gösterilmiştir. Sonuç olarak, pozitif arka köprü sisteminde üç çubuk mekanizması ve kam tahrikiyle elde edilen standart bir hareket eğrisinin değişik kumaş tipleri ve tezgah ayarları için yeterli olmadığı, motor tahrikli arka köprüyle değişik hareket eğrileri üretilerek farklı kumaş tiplerinin dokunmasına uygun çözgü uzama veya çözgü gerginlik eğrisi elde edilebileceği değerlendirilmiştir.

Anahtar Kelimeler: Dokuma, Arka köprü, Pozitif arka köprü, Çözgü uzaması, Çözgü gerginliği.

Corresponding Author: Recep Eren, erecep@uludag.edu.tr. Tel: +90 224 294 20 43

1. INTRODUCTION

Let-off mechanisms transfer the necessary amount of warp yarn from warp beam to the weaving area of the loom at the tension required for weaving process. During weaving, due to the basic weaving motions warp tension changes cyclically. However, the average warp tension is required to be kept constant to obtain a constant weft density and homogenous fabric properties. There seems to be no doubt that warp tension fluctuation during weaving can cause warp breaks and decreases the fabric quality if it is not taken under control.

Let off motions consist of warp beam, beam drive unit, backrest and warp tension measuring and control unit. The main function of the backrest is to compensate for warp tension fluctuations caused by shedding and beat up actions. The backrest has also the function of compensating medium and long term tension variations. Although the fixed backrest is used only for some special applications, the swinging backrest dominates the industry. There are different types of backrest designs used in industry. These can be classified as negative, positive and metal plate backrest types.

In negative backrests, warp tension drives the backrest and the backrest motion is dependent upon its own law of motion. The motion of the backrest differs at different loom speeds and under different weaving conditions. It is most widely used backrest type in weaving industry.

In positive backrests, the swinging motion of the backrest is obtained positively by linkages, cam or an individual motor. Therefore, the motion of the backrest is independent of machine speed and weaving conditions. It is mainly used with high speed air jet and water jet looms.

Metal plate backrest has been introduced in recent years and currently used in weaving technical fabrics mainly produced by high performance fibers like Kevlar®. It is the bending of the metal plate that compensates the elongation in warp yarns due to shedding and beat up. As there is no moving mass of the backrest, the inertial effects are mostly eliminated and the backrest acts almost like a spring. To adjust the amount of compensation, metal plates of different stiffness are used in weaving of different fabrics.

There are some published materials on backrest systems in the literature. These are mainly connected with the negative type of backrest. Foster studied the behavior of negative type of backrest (1). After his mathematical analysis, he concluded that a sensitive backrest to shedding and beat up actions was advantageous in shuttle looms to reduce warp breaks, but less sensitive backrest became more important for shuttleless looms due to smaller shed size requirements. Use of controlled dampers in negative backrest was mentioned first time by Foster. Kamogawa (2) and Tumer and Bozdog (3) developed mathematical models for weight and spring loaded negative backrests for the analysis of its performance to short term disturbances like shedding action. It is concluded that the backrest became insensitive to short term disturbances at around 100 rad/s loom speed and insensitivity limit could be reduced to 30-40 rad/s by increasing effective backrest inertia and/or damping coefficient.

M. Kloppels et al. investigated the performance of freely programmable motor driven positive backrest experimentally (4). They developed and mounted the motor driven backrest system to an air jet loom in industry. They developed motion curves for the backrest taking into account parameters like fabric construction, warp yarn properties and warp drawing-in and weaving machine settings and tested the performance of the motor driven positive backrest for a 6-pick twill under industrial conditions. They concluded that warp breaks were reduced by servomotor driven backrest around %61 compared to weaving machines with negative backrest and %74 compared to identical weaving machines.

Although it is mainly used on high speed air jet and water jet looms for weaving especially heavy and/or spun yarn fabrics, no detailed study has been found in the literature on positive backrest motions. It is the aim of this study to analyze theoretically the warp tension in weaving process with positive backrest and to show the effect of some technological parameters on warp elongation curves within one loom revolution.

2. MATERIAL

Fig. 1 shows schematically the cross section of a loom shed and a positive backrest on a weaving machine. A crank rocker mechanism is used to drive the backrest positively. Link 2 rotates continuously at loom speed. The motion of the link 2 is transmitted to the link 4 by the connecting link 3. In one revolution of the link 2, the link 4 swings in clockwise and anticlockwise directions. The link 4 is pivoted at point 'O' together with fixed backrest roller (f). The movable roller (m) is mounted to the other hand of the link 4 and swings together with it. Both fixed and movable rollers can rotate around their own axes. During the shed opening, the backrest (the link 4 and roller m) moves in clockwise direction and limits the increase in warp elongation to some extent. During the closing of the shed, the backrest rotates in counter clockwise direction and limits the reduction in warp elongation. In this way, the elongation (i.e tension) in warp yarns is compensated at a predetermined amount during shed formation.

Although there are different types of sheds used in weaving process depending on the requirements of the fabrics, a symmetrical shed (i.e, warp yarns move equal amount to the upper and lower shed positions) will be considered in this study. A crank rocker mechanism is preferred in the analysis because it is most widely used drive mechanism for the positive backrest in industry.

3. METHOD

3.1. Heddle and backrest motion curves

Warp elongation or warp tension in weaving is affected by heddle and backrest movements. Depending on the fabric type, it is also affected by reed motion during cloth fell displacement at beat up. For open or relatively open fabrics, cloth fell displacement is very low and this has very little effect on warp elongation during beat up. As cloth fell displacement gets larger with increasing weft density or increasing fabric cover factor, warp elongation also increases during beat up. Positive backrest has only a limited compensation on warp elongation during beat up as the beat up is carried out in a short period of time. Therefore, it can be assumed that the cloth fell displacement during beat up corresponds directly to the warp elongation added to the warp elongation due to shedding. As the warp elongation due to beat up depends on fabric type and can be simply added to the shedding elongation as a cloth fell displacement, it is not included in the mathematical analysis in this study.

It is required to define the motion curves of heddle and backrest mechanisms to be able to carry out the mathematical analysis. Simple harmonic motion curve is chosen for the heddle motion to simplify the mathematical analysis and expressed for its rise and return periods by Eq.1 to Eq.4.

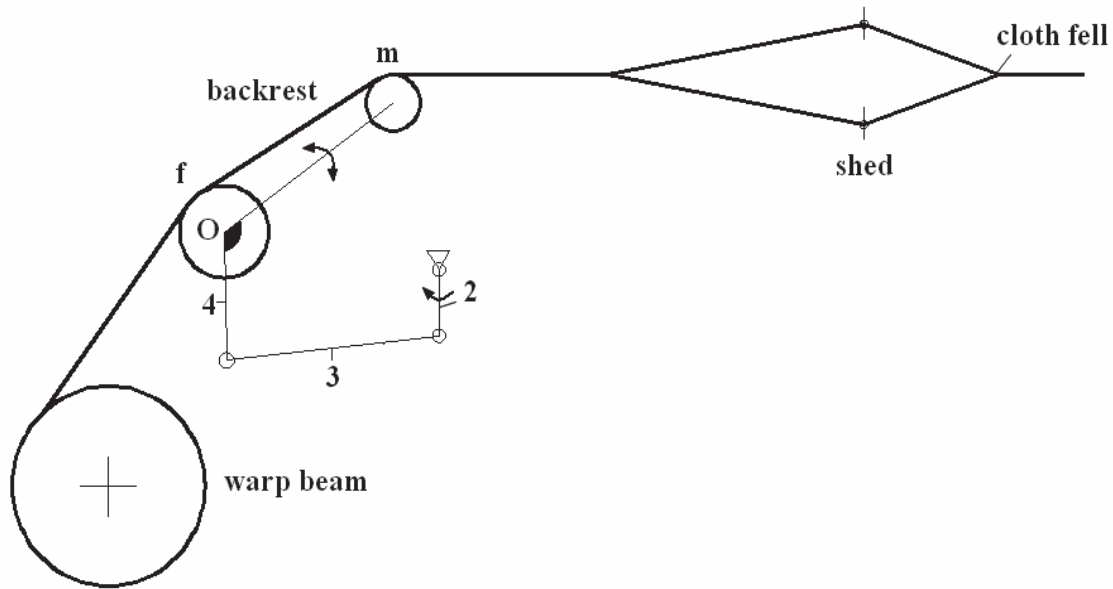

Figure 1. Cross section view of weaving shed and a positive backrest.

$$h = \frac{h_0}{2} \left\{ 1 - \cos \left(\frac{\pi\theta}{\beta_r} \right) \right\} \quad \text{for } \theta=0 \text{ to } \beta_r \quad (1)$$

$$h = h_0 \quad \text{for } \theta= \beta_r \text{ to } 360 \quad (2)$$

$$h = h_0 - \frac{h_0}{2} \left\{ 1 - \cos \left(\frac{\pi(\theta-360)}{\beta_d} \right) \right\} \quad \text{for } \theta= 360 \text{ to } 360+\beta_d \quad (3)$$

$$h = 0 \quad \text{for } \theta= 360+\beta_d \text{ to } 720 \quad (4)$$

where,

- θ = angle of loom main shaft.
- h = heddle displacement starting from the bottom position.
- h_0 = total heddle displacement.
- β_r = main shaft angle interval corresponding to the heddle rise period.
- β_d = main shaft angle interval corresponding to the heddle return period.

The motion of the backrest driven by a centric crank rocker mechanism is assumed to be simple harmonic motion as the ratio of the length of link 2 to the length of link 3 is too low. Thus, clockwise and anticlockwise angular displacements of the backrest are given by Eq.5 and Eq.6 respectively.

$$\varphi = \frac{\varphi_0}{2} \{ 1 - \cos \theta \} \quad \text{for } \theta=0^\circ \text{ to } 180^\circ \quad (5)$$

$$\varphi = \varphi_0 - \frac{\varphi_0}{2} \{ 1 - \cos(\theta - 180) \} \quad \text{for } \theta=180^\circ \text{ to } 360^\circ \quad (6)$$

where,

- φ = backrest angular displacement.
- φ_0 = total swinging angle.

The parameters defined above for heddle and backrest motions are shown in Fig.2a and Fig.2b.

Heddle and backrest motion curves can be expressed graphically by using equations 1, 2, 3 and 4. Fig. 3.a and b show heddle displacement for plain weave over two loom revolutions with and without dwell periods respectively. The curves have been obtained with 330 degrees shed closing angle in both figures. Shed closing angle is a technological

parameter that can be adjusted to different values for different fabric types. In this study, the effect of shed closing angle on warp elongation curve will be investigated for 360, 330 and 300 degrees. It should be noted here that the heddle displacement given in Fig. 3.a and b is for the first and second heddles from the front of the loom. Warp elongation curves in Section 4 are also given for the first heddle.

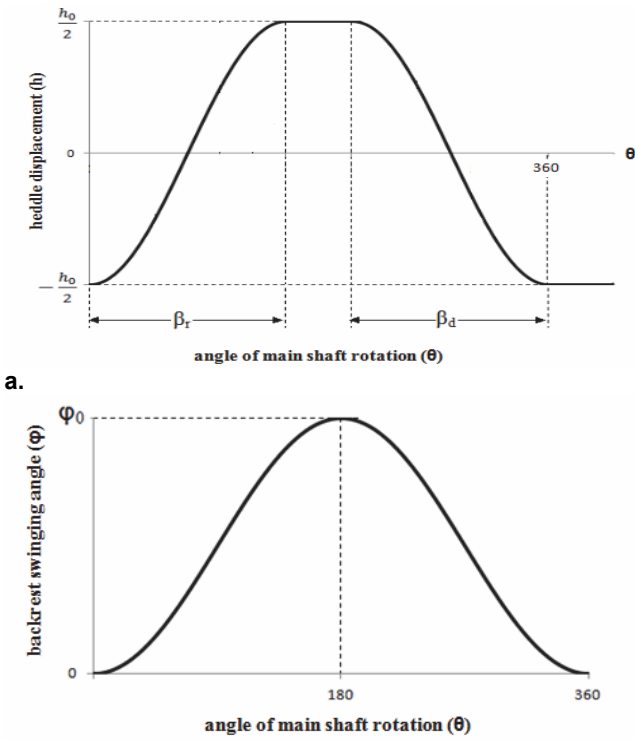
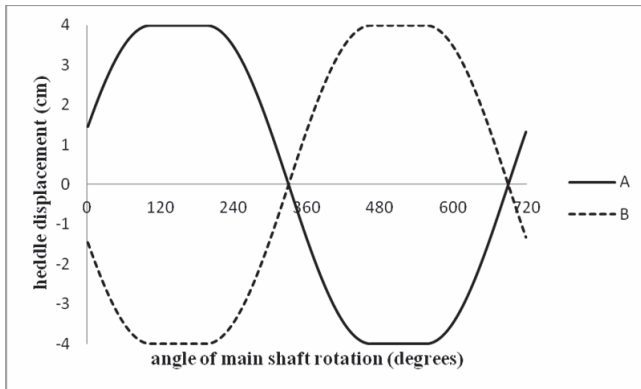
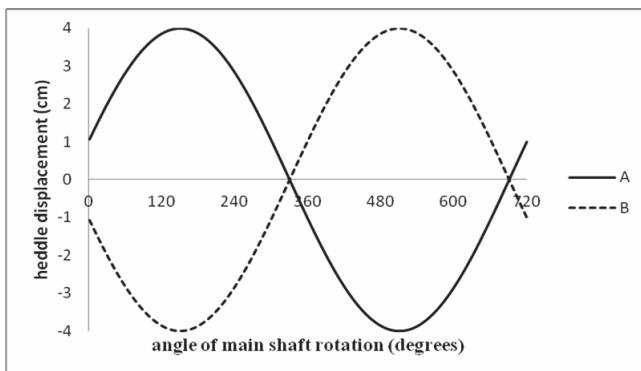

Figure 2. Parameters of heddle and backrest motions shown on the curves.



a. With dwell (dwell angle: 90 degrees, A: 1.heddle, B: 2.heddle).



b. Without dwell (A: 1.heddle, B: 2.heddle).

Figure 3. Heddle displacement curves.

The backrest motion curve used in this research is given in Figure 4. The curve is obtained for 2 degrees of backrest swinging angle. The backrest is normally at most backward

position at zero and it is at most forward position at 180° loom main shaft angle. But, the timing of the backrest movement can be shifted forward or backward with respect to the heddle and sley motions. This shift in backrest timing is called phase difference and expressed in terms of loom main shaft rotation such as +30, -30. The effect of backrest phase difference on warp elongation will be investigated in this study for 0, +30, -30, +60 and -60 degrees.

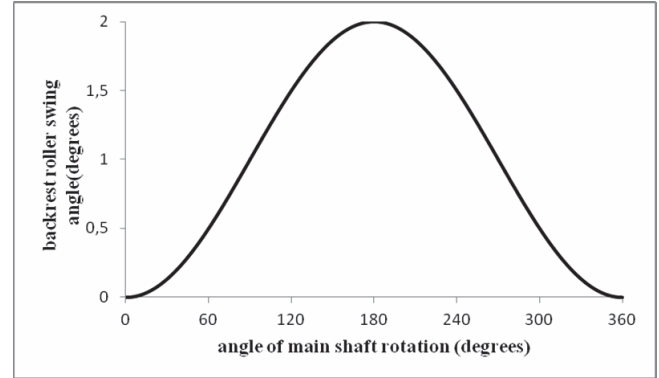

Figure 4. Backrest motion curve.

3.2. Warp yarn elongation due to shedding (ΔL_s)

Total elongation in warp yarns (ΔL) is determined by shedding elongation (ΔL_s) and backrest compensation (ΔL_b) and can be written by Eq. 7. ΔL_b has a negative value as it limits the total elongation. As was mentioned above, Eq. 7 ignores warp elongation due to beat up.

$$\Delta L = \Delta L_s + \Delta L_b \quad (7)$$

The elongation in warp yarns due to shed opening can be expressed as follows considering Fig. 5.

$$\Delta L_s = (L_x + L_y) - (L_{0x} + L_{0y}) \quad (8)$$

L_x , L_y , L_{0x} , L_{0y} are the distances shown in Fig.5. L_{0x} and L_{0y} are fixed lengths on the loom. In this study, L_{0x} and L_{0y} are taken as 150 mm and 550 mm respectively. L_x and L_y are the warp lengths that change with respect to loom main shaft angle during shed opening and closing.

L_x and L_y can be calculated as follows.

$$L_x = \sqrt{L_{0x}^2 + \Delta h^2} \quad (9)$$

$$L_y = \sqrt{L_{0y}^2 + \Delta h^2} \quad (10)$$

Δh = heald frame displacement starting from closed shed position.

3.3. Backrest compensation (ΔL_b)

Fig. 6 shows two positions of the positive backrest. Position I is the most backward position represented by α_0 (orientation angle) and position II is any position of the backrest during its motion and represented by α_n . The difference between α_0 and α_n corresponds to backrest angular displacement (φ) calculated by Eqs. 5 and 6. Cloth fell is denoted by point 'F' and it is assumed to be on the same horizontal line with point 'G'. The amount of backrest

compensation (ΔL_b) is calculated by Eq.11 as a change between the warp lengths of position I (L_I) and position II (L_{II}). In both positions, the warp length is calculated as the distance between point 'A' and point 'F'. As the warp length between warp beam and point 'A' of the fixed backrest roller (f) does not change during backrest motion, it is not taken into account in the calculation of ΔL_b . In Fig.6, ' r_1 ' and ' r_2 ' are the radii of fixed and movable rollers and 'X' represents the distance between the centers of fixed and movable rollers. 'U' is the horizontal distance between cloth fell position (point F) and the center of fixed roller.

$$\Delta L_b = L_{II} - L_I \quad (11)$$

L_I and L_{II} can be calculated as follows considering Fig.6.

$$L_I = |AB| + \widehat{BG} + |GF| \quad (12)$$

$$L_{II} = \widehat{AC} + |CD| + \widehat{DE} + |EF| \quad (13)$$

Lengths of $|AB|$, $|GF|$, $|CD|$, $|EF|$, \widehat{AC} , \widehat{BG} and \widehat{DE} can be calculated as follows using geometrical relations.

Calculation of $|GF|$

Referring to Fig.6, the mathematical expression to calculate $|GF|$ can be written as follows.

$$|GF| = U - X \cos \alpha_0 \quad (14)$$

Calculation of $|AB|$ and $|CD|$

As 'A' and 'B' are the tangent points to the fixed and moveable rollers, $|AB|$ can be calculated using Pythagoras theorem according to Fig.7. Because 'C' and 'D' are also tangent points to the same rollers, $|AB|$ is equal to $|CD|$. $|AB|$ and $|CD|$ remain unchanged during the motion of the backrest due to the constant values of X, r_1 and r_2 .

$$|AB| = |CD| = \sqrt{X^2 - (r_1 - r_2)^2} \quad (15)$$

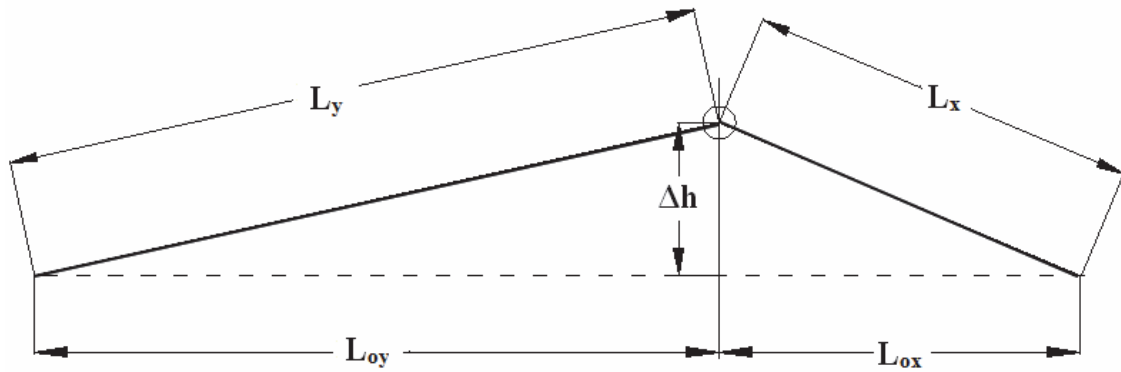

Figure 5. View of shed geometry.

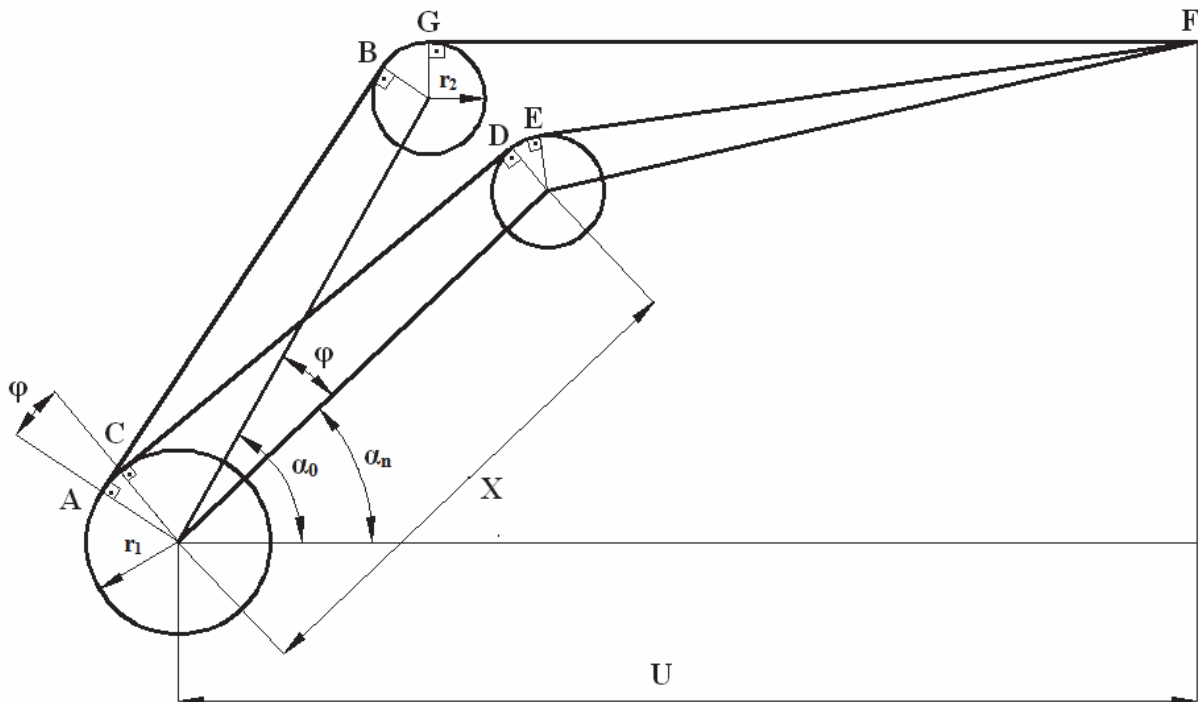

Figure 6. Two positions of positively driven backrest.

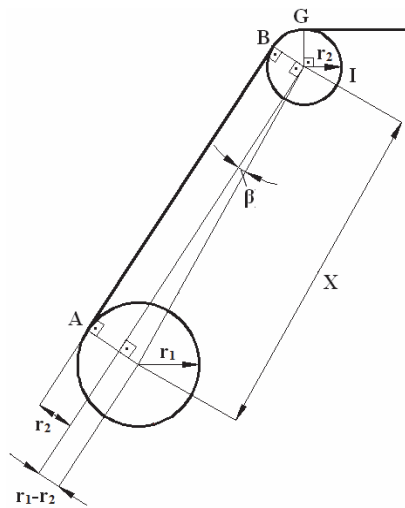

Figure 7. Backrest geometry for the calculation of |AB|.

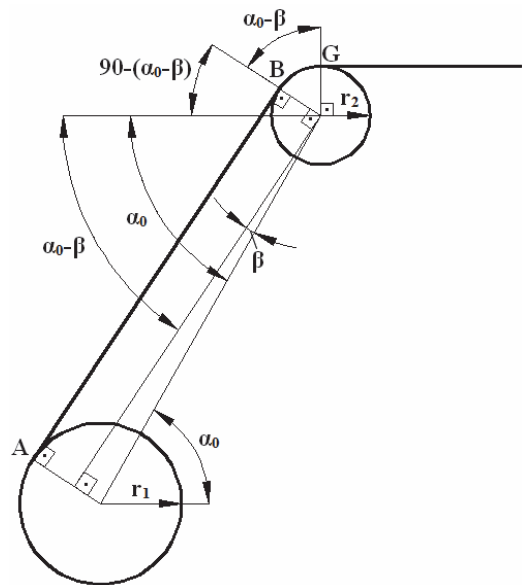

Figure 8. Geometrical relations for the calculation of arc length of BG.

Calculation of arc length of AC

Warp yarns wrap additionally around the fixed backrest roller the same amount as the rotation of the backrest (i.e., φ). Therefore the length of arc AC can be given by Eq.16 considering Fig.6.

$$\widehat{AC} = r_1 \varphi \quad (16)$$

Calculation of arc length of BG

Fig.8 shows the geometry for the calculation of the arc length of BG. The arc length of BG corresponds to the length of angular span of $\alpha_0 - \beta$. Therefore, it can be written by Eq.17.

$$\widehat{BG} = r_2 (\alpha_0 - \beta) \quad (17)$$

Where $\beta = \arcsin \frac{(r_1 - r_2)}{X}$ can be written considering Fig.7.

Calculation of |EF|

Due to the geometrical relations shown in Fig.9, |EF| can be calculated as follows.

$$\Delta P = X (\sin \alpha_0 - \sin \alpha_n) \quad (18)$$

$$P = \Delta P + r_2 \quad (19)$$

$$\Delta R = X (\cos \alpha_n - \cos \alpha_0) \quad (20)$$

$$R = |GF| - \Delta R \quad (21)$$

$$|KF| = \sqrt{P^2 + R^2} \quad (22)$$

$$|EF| = \sqrt{|KF|^2 - r_2^2} \quad (23)$$

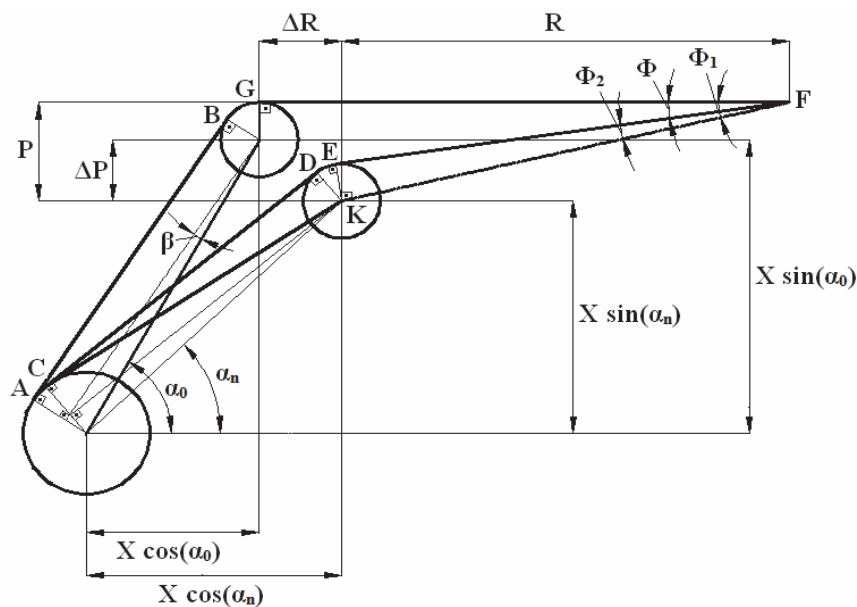

Figure 9. Geometrical relations for the calculation of |EF|.

Calculation of arc length of DE

Arc length of DE is expressed by Eq.24 considering the geometrical relations in Fig.10.

$$\widehat{DE} = r_2(\alpha_n - \beta - \Phi) \quad (24)$$

Where $\phi = \phi_1 - \phi_2$ and ϕ_1 and ϕ_2 are calculated by Eq.26 and Eq.27 using the geometry in Fig.9.

$$\alpha_n = \alpha_0 - \varphi \quad (25)$$

$$\Phi_1 = \arctan\left(\frac{P}{R}\right) \quad (26)$$

$$\Phi_2 = \arctan\left(\frac{r_2}{|EF|}\right) \quad (27)$$

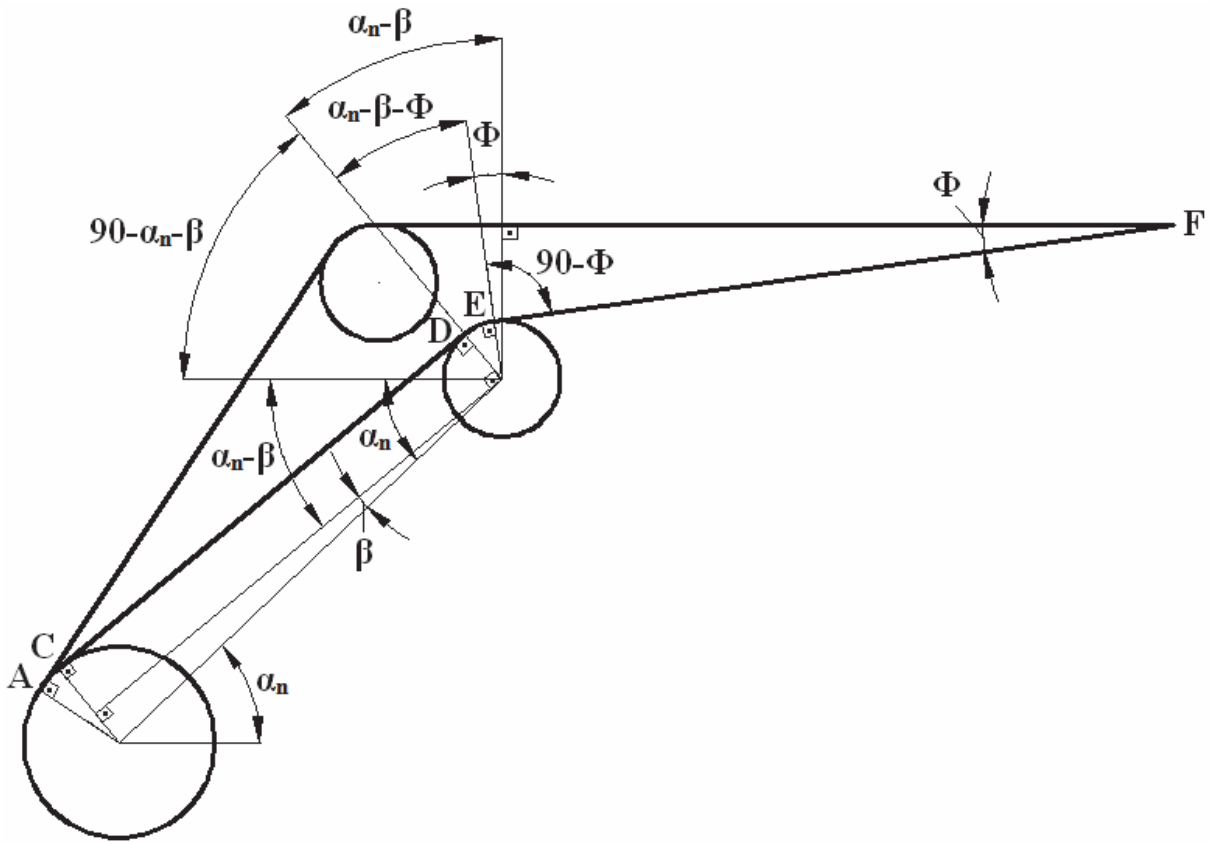

Figure 10. Geometrical relations for the calculation of arc length DE.

Total elongation in warp yarns (ΔL) can be determined using the equations between 1 and 26 for each main shaft angle over a loom revolution. Warp tension is then calculated for each main shaft angle over a loom revolution by Eq.28 where ε is the unit elongation of warp yarns and E is Young modulus of warp-fabric system. Unit elongation (ε) is given by Eq.29. L in Eq.29 represents the total warp length measured between the warp beam and cloth fell when the shed is closed.

$$T = E \varepsilon \quad (28)$$

$$\varepsilon = \frac{\Delta L}{L} \quad (29)$$

4. RESULTS AND DISCUSSION

The results are calculated from above equations with the following values of constant parameters of U, X, L, r_1 and r_2 . The effect of backrest angular orientation (α_0) and backrest swinging angle (φ_0), shed closing angle and backrest phase difference on warp elongation (or warp tension) is investigated. The results are presented in the figures in terms of percent warp elongation. But, as was mentioned above warp tension curves can be obtained by multiplying unit elongation (percent elongation/100) with Young modulus (E) of warp-fabric system (Eq.28).

U=830 mm, X=120 mm, L=1700 mm, r_1 =55 mm and r_2 =25 mm.

4.1. The effect of backrest orientation angle (α_0) and backrest swinging angle (φ_0) on warp elongation

The effect of backrest swinging angle on warp elongation is presented in Fig.11 and 12 with heddle motion without dwell. The backrest orientation angles are 80° and 60° in Fig.11 and 12 respectively. As shown in both figures, the greater backrest swinging angle limits warp elongation at a higher amount as expected. Comparing Fig.11 with Fig.12 reveals that backrest compensates warp elongation more at its higher orientation values (i.e., warp elongation is compensated more at 80° than 60°). At higher swinging angles, warp elongation becomes negative at shed closing phase, which means that the backrest compensates warp elongation more than shedding elongates. By adjusting pretension of warp yarns, the negative values of warp elongation can be prevented. But, this might increase warp elongation unnecessarily during shed opening phase.

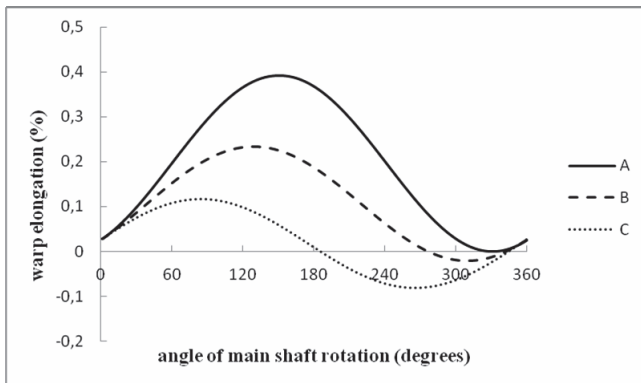

Figure 11. Effect of backrest swinging angle on warp elongation without heddle dwell and $\alpha_0=80^\circ$ (A: fixed backrest, B: $\varphi_0=2^\circ$, C: $\varphi_0=4^\circ$).

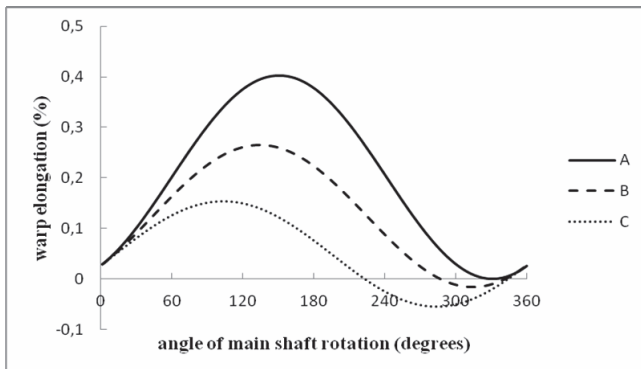

Figure 12. Effect of backrest swinging angle on warp elongation without heddle dwell period and $\alpha_0=60^\circ$ (A: fixed backrest, B: $\varphi_0=2^\circ$, C: $\varphi_0=4^\circ$).

Fig.13 and Fig.14 show the effect of backrest swinging angle on percent warp elongation with heddle motion with dwell for backrest orientation angles of 80° and 60° respectively. In this case too, warp elongation is limited at a higher ratio with increasing swinging and orientation angles as expected. Compared to no heddle dwell curves in Fig.11 and 12, warp elongation becomes negative at a lower amount for a shorter period. Depending on the warp yarn type and fabric structure, the value of backrest swinging angle can be adjusted on the loom according to the requirement of fabric being woven.

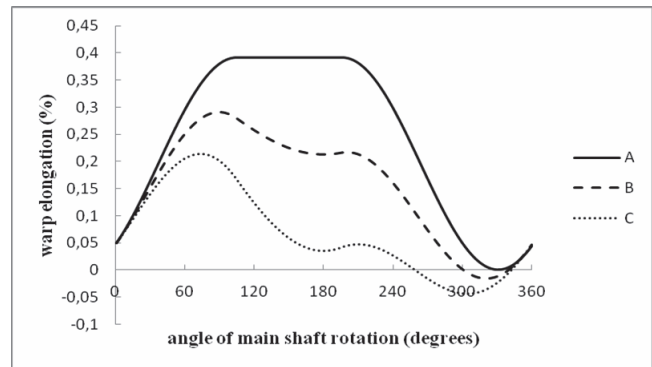

Figure 13. Effect of backrest swinging angle on warp elongation with heddle dwell and $\alpha_0=80^\circ$ (A: fixed backrest, B: $\varphi_0=2^\circ$, C: $\varphi_0=4^\circ$).

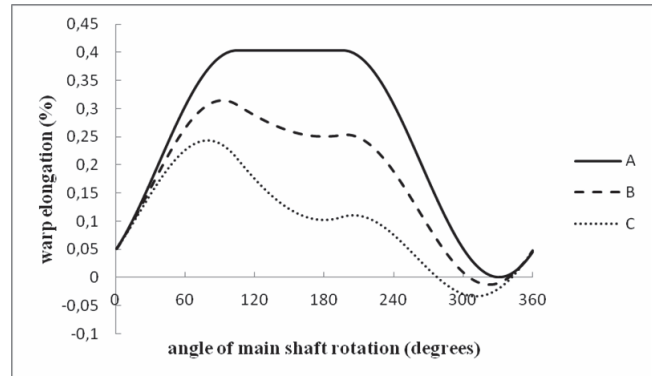

Figure 14. Effect of backrest swinging angle on warp elongation with heddle dwell and $\alpha_0=60^\circ$ (A: fixed backrest, B: $\varphi_0=2^\circ$, C: $\varphi_0=4^\circ$).

4.2. The effect of shed closing angle on percent warp elongation

In Fig.15 and 16, percent warp elongation curves are given for heddle motions with and without dwell periods respectively for backrest swinging angle of 2° and shed closing angles of 300° , 330° and 360° . As shown in Fig.15, when there is no dwell in the heddle motion warp elongation decreases with increasing shed closing angles. As shed closing angle decreases, warp elongation (i.e., warp tension) becomes higher during beat-up and reaches a higher maximum value. On the other hand, the warp elongation becomes negative earlier and for a longer period and its negative value increases with decreasing shed closing angles.

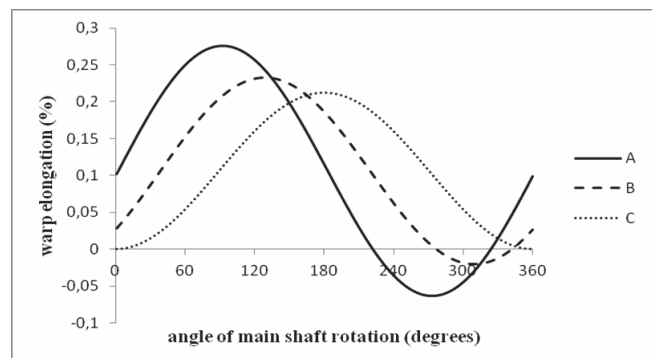

Figure 15. Effect of shed closing angle on warp elongation without heddle dwell and $\varphi_0=2^\circ$ (A: shed closing angle = 300° , B: shed closing angle = 330° , C: shed closing angle = 360°).

Warp elongation also increases with a decrease in shed closing angle in the case of heddle motion with dwell period, as shown in Fig.16. Earlier shed closing angle increases maximum warp elongation as well as warp elongation at beat up. Comparing warp elongation curves in Fig.15 and Fig.16 shows that both maximum warp elongation and warp elongation at beat up are higher for heddle motion with dwell than without dwell. But, negative warp elongation period and its value decrease with heddle motion with dwell.

Adjusting shed closing angle earlier increases warp elongation and therefore warp tension at beat up and supports weaving conditions to weave fabrics with a higher cover factor or higher weft densities. But, increase in maximum warp elongation and higher absolute values of negative warp elongation with earlier shed closing have disadvantages for weaving process. This can be prevented by adjusting backrest phase difference in synchronism with shed closing angle as shown in Fig.17. In this case, the same warp elongation or warp tension curves are obtained with phase shift corresponding to the shed closing angle shift.

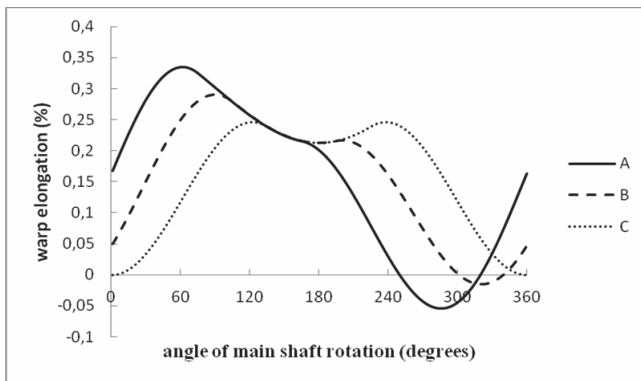

Figure 16. Effect of shed closing angle on warp elongation with heddle dwell and $\varphi_0=2^\circ$ (A: shed closing angle =300°, B: shed closing angle =330°, C: shed closing angle =360°).

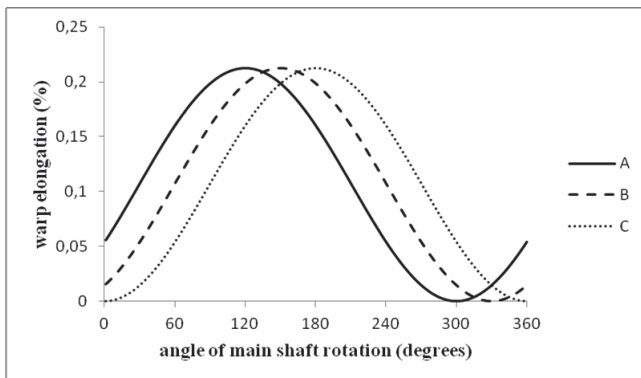

Figure 17. Effect of shed closing angle on warp elongation without heddle dwell and $\varphi_0=2^\circ$ (A: shed closing angle =300°, B: shed closing angle =330°, C: shed closing angle =360°). Backrest timing is adjusted in synchronism with shed closing angle.

4.3. The effect of backrest phase difference on percent warp elongation

The effect of backrest phase difference on warp elongation is presented in Figs.18 to 21. All figures are obtained for 2°

backrest swinging angle and 330° shed closing angle. With both dwell and without dwell heddle motions, warp elongation values become less during shed opening period and higher during shed closing period with increasing absolute value of negative phase difference (Figs.18 and 19). Maximum values of warp elongation are very close to each other. In the case of positive backrest phase differences, warp elongation increases at a higher rate during shed opening period and decreases quicker during shed closing period with increasing phase difference. In contrast to negative phase difference, positive phase difference causes higher maximum warp elongation and negative minimum warp elongation. The effect of both negative and positive phase differences shows same trend for heddle motions with and without dwell. From technological point of view, positive phase difference might be an advantage in weaving fabrics from the warp yarns that entangle during shed opening. Increasing warp elongation and therefore warp tension during shed opening supports warp separation in the shed during shed opening. On the other hand, the positive phase difference reduces warp elongation around shed crossing. This encourages the warp entanglement in the shed around shed crossing period. Early shedding with synchronous backrest phase difference can produce better results in reducing shedding entanglements.

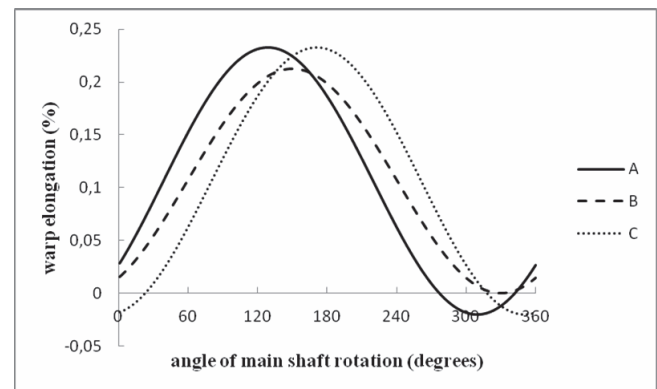

Figure 18. Effect of backrest negative phase difference on warp elongation without heddle dwell and backrest swinging angle of $\varphi_0=2^\circ$ (A: without phase difference, B: phase difference = - 30°, C: phase difference = - 60°)

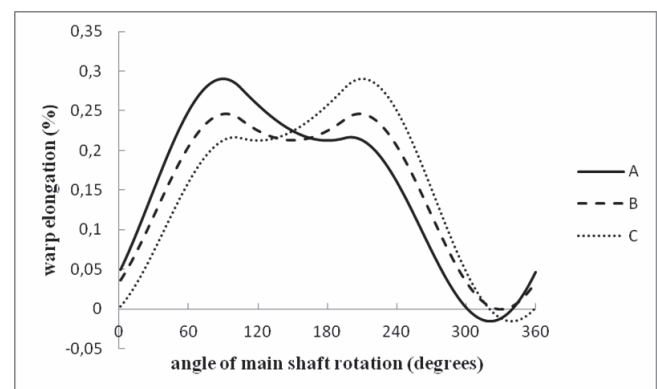

Figure 19. Effect of backrest negative phase difference on warp elongation with heddle dwell and $\varphi_0=2^\circ$ (A: without phase difference, B: phase difference = - 30°, C: phase difference = - 60°)

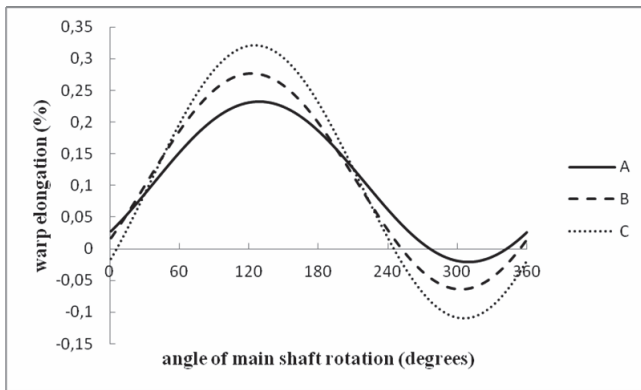

Figure 20. Effect of backrest positive phase difference on warp elongation without heddle dwell and $\phi_0 = 2^\circ$ (A: without phase difference, B: phase difference $= + 30^\circ$, C: phase difference $= + 60^\circ$).

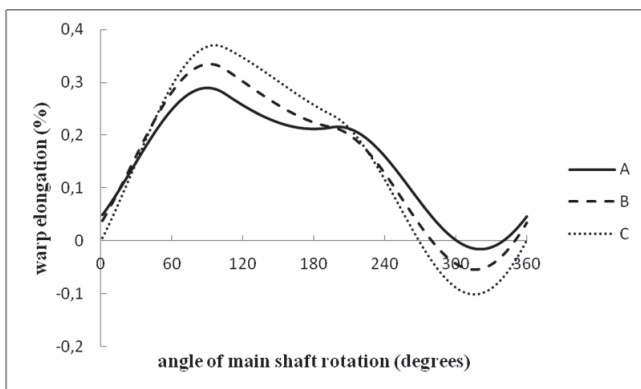

Figure 21. Effect of backrest positive phase difference on warp elongation with heddle dwell and $\phi_0 = 2^\circ$ (A: without phase difference, B: phase difference $= + 30^\circ$, C: phase difference $= + 60^\circ$).

4. CONCLUSION

Mathematical analysis of warp elongation (i.e., warp tension) in weaving with a crank rocker mechanism driven positive backrest has been carried out and the effect of backrest swinging angle, backrest orientation angle, shed

closing angle and backrest phase difference on warp elongation has been investigated for a symmetrical shed. An increase in both backrest swinging angle and backrest orientation angles has increased compensation in warp elongation due to shedding. Depending on the type of warp yarn, warp elongation or warp tension can be adjusted by changing backrest swinging angle on the loom. Shed closing angle is a parameter which is adjusted to different values mostly between 345° - 300° of main shaft angle in weaving different type of fabrics. Adjusting shed closing angle earlier (towards 300°) without changing the phase difference causes an increase in warp elongation at beat up as well as in maximum warp elongation. Changing backrest phase difference in synchronism with shed closing angle does not increase maximum warp elongation and shifts the same warp elongation or warp tension curve. In this way, warp tension at beat up can be increased or decreased without changing its maximum value. Backrest phase difference is another parameter that has a significant effect on warp elongation curve. Both negative and positive values of phase difference reduce warp elongation at beat up but increasing values of positive phase difference has increased warp elongation at a higher rate during shed opening. For this reason, higher values of positive phase difference can be used in weaving fabrics with crossing warps in the shed.

Warp elongation in a weaving machine with positive backrest is determined by the motion curves of heddles and backrest. Heddle motion curve is designed according to the requirements of shed geometry and optimum dynamic behaviour of heddles. With crank rocker type of drive mechanism, the backrest motion approximate simple harmonic motion. Only one selected motion curve is obtained even with the cam driven positive backrest. In this case, it is not possible to obtain an ideal warp elongation (or tension) curve for all fabric types. Only one motion curve for the positive backrest can not meet the requirements of different fabric types and loom settings. Motor driven positive backrest has advantages over crank or cam driven types as it allows changing backrest motion curves. Backrest motion curves designed for different fabric types can be implemented by a servo motor to obtain the suitable warp elongation or tension curve.

REFERENCES

1. Foster, R., 1972. WIRA Report, No:179.
2. Kamogawa, H., 1959. "Automatic Control of Feeding Devices of Weaving Machines", *Journal Of Textile Machinery Society of Japan*, Yil:12(9), s:32-35.
3. Tümer, T. ve Bozdağ, M., 1986. "Mathematical Description Of The Operation Of Positive Let Off Motions", *The Journal Of The Textile Institute*, 1, s: 44-55.
4. Klöppels, M., Gries, T., Bösing, T., Pothoff P.-J., 2002. "Practical Trial of the Freely Programmable Active Back Rest Roller System", *Melliand International*, 8, s:115-116.