

ARAŞTIRMA MAKALESİ / RESEARCH ARTICLE

DESIGN AND ANALYSIS OF A NOVEL ROBOTIC ARM FOR HIGH PRECISION MICRO FRICTION STIR WELDING

Azhar Majid Qasim ALGHLOOM¹¹Mechanical Engineering, Altinbas University, Istanbul, Turkey
azharalghloom@gmail.com, ORCID: 0000-0002-1322-2732Serdar AY²²Mechanical Engineering, Altinbas University, Istanbul, Turkey
serdar.ay@altinbas.edu.tr, ORCID: 0000-0002-1698-9832GELİŞ TARİHİ/RECEIVED DATE: 03.02.2022 REVİZYON TARİHİ/REVISION DATE: 16.03.2022
KABUL TARİHİ/ACCEPTED DATE: 25.03.2022**Abstract**

The usage of industrial robots in manufacturing industries has revolutionized the traditional manufacturing process into more diverse and sustainable modern manufacturing processes. This paper presents the design and analysis of a 6-DOF robotic arm, which will perform a highly précised micro friction stir welding process. Friction stir welding is a technology that is constantly evolving. It has played a vital role in connecting metals in numerous sectors since its invention in 1991, and one of the outcomes of its development is micro friction stir welding, which was invented in 2004. There are numerous advantages that a designed robotic arm possesses over other traditional micro friction stir welding machines, which include high precision, sustainability, flexibility, time, and cost-effectiveness, along with a small operation area. The robotic arm is designed in two phases; the first stage is a design of links and revolute joints, respectively, and high-speed motor selection for the end effector to operate at high torques with required precision and accuracy. In the second phase, the designed model was analyzed using ANSYS software. In this phase, the transient and structural analyses are performed to analyze the performance of the robotic arm under various conditions.

Keywords: Friction stir welding, Micro friction stir welding, Robotic arm.

YENİ BİR ROBOT KOLONUN TASARIMI VE ANALİZİ İÇİN YÜKSEK HASSASİYETLİ MİKRO KURGU KARIŞTIRMA KAYNAĞI

Özet

Endüstriyel robotların imalat sanayiinde kullanımı, geleneksel üretim sürecini daha çeşitli ve sürdürülebilir modern üretim süreçlerine dönüştürmüştür. Bu makale, son derece hassas bir mikro sürtünme karıştırma kaynağı işlemini gerçekleştirecek olan 6-DOF robotik bir kolun tasarımını ve analizini sunmaktadır. Sürtünme

karıştırma kaynağı devamlı gelişen bir teknolojidir. 1991 yılında icadından bu yana birçok sektörde metallerin birleştirilmesinde hayati bir rol oynayan sürtünme karıştırma kaynağının gelişiminin sonuçlarından biri de 2004 yılında icat edilen mikro sürtünme karıştırma kaynağıdır.

Tasarlanan robot kol ile gerçekleştirilecek micro sürtünme karıştırma kaynağının, yüksek hassasiyet, sürdürülebilirlik, esneklik, zaman ve maliyet etkinliği sayesinde diğer geleneksel mikro sürtünme karıştırma kaynak makinelerine göre sahip olduğu birçok avantaj vardır.

Robotik kolu iki aşamada tasarlanmıştır. İlk aşamada: sırasıyla uzuvların ve döner eklemlerin tasarımı ve uç işlevcinin gerekli hassasiyet ve doğrulukla yüksek torklarda çalışması için yüksek hızlı motor seçimi, ikinci aşamada ise; tasarlanan model, ANSYS yazılımı kullanılarak analiz edilmiştir. Bu aşamada, robotik kolun performansını çeşitli koşullar altında analiz etmek için geçici ve yapısal analizler yapılır.

Anahtar Kelimeler: Sürtünme karıştırma kaynağı, Mikro sürtünme karıştırma kaynağı, Robot kol.

1. INTRODUCTION

Friction stir welding (FSW) is a solid-state welding process that joins two metals together without melting. Wayne Thomas of The Welding Institute created this process in 1991, and it has rapidly evolved over the subsequent few decades (Fersini and Pironi, 2007). When compared with all other welding processes, this method provided little deformation and good joint strength and can weld alloys that are either impossible to weld or very difficult to melt. It operates at a much lower melting temperature of metals, and it takes place in a solid state. This process eliminates cracking, porosity, second phase formation, and embrittlement related to metal's re-solidification. Since the operational temperature of this process is low, it ultimately reduces the thermal stress development and distortion. FSW welding process is also cost-efficient and energy-efficient as it does not require any additional filler material while joining the metals, and shielding gas is not required in many cases. Unlike traditional fusion welding techniques, this method lacks the arcs flash, fumes, spatter, and pollution. Friction stir welding can be used to weld sheets ranging from 0.5mm to 6.5mm to their full penetration without having any defects like cracking, porosity, or internal voids (Bharat et. al., 2014). The conventional FSW is the earliest demonstration of the technique and is a mostly adopted technique in all industries. In this technique, a rotating tool consisting of a probe and a shoulder is used. The tool is inserted into the two metals. The tool's rotational motion generates heat, and the resulting plastic deformation causes the diffusion of both the metals' atoms to join. Micro friction stir welding (μ FSW) is a kind of friction stir welding that is used to combine materials with thick of less than 1000 μ m (1 mm) (Sen et. al., 2019). Manufacturers' demands are increasing daily for the micro joining of pieces to produce lightweight and small-sized products. The welding of heavy metals has developed to much extent, but small and soft material is a challenge for present science. FSW is an ideal way to produce cost-efficient parts and high-strength joints. The joining of small parts is required in the electronic industry, where micro-scale welding is performed. Among these micro-welding technologies, soldering and brazing are two methods that cannot meet the requirements in terms of reliability, elevated joint resistance, and durability of joints (Salih et. al., 2015). Micro-scale friction stir welding is a recently proposed approach that can be used to connect microscale electrical, microscale mechanical, and microscale electronic components (Padhy et. al., 2018).

1.1. Robotics In Friction Stir Welding (FSW) And Micro Friction Stir Welding μ FSW

Although the utilization of robots for friction stir welding (FSW) represents a few difficulties contrasted with regular, sold FSW machines. Ongoing progressions in machine technology, along with nova FSW methods have expanded the capability of FSW robots ultimately. FSW can be done on a variety of machinery, including processing machines, specialized FSW machines, and template machines. Nonetheless, modern robots have been used in the field of FSW because of the benefits of a broad workspace, condensed construction, remarkable adaptability, and reasonable cost involved when compared to machine instruments (Scialpi et. al., 2008). A significant portion of industrial robots is articulated arm robots, which have a serial chain of links and typically six rotary joints controlled by electric servomotors. There is high demand for the typical FSW machine because of the high force necessary for FSW. As a result, FSW was initially unsuitable for such industrial robots. The TWI (the welding institute) has developed the robots for FSW and also some conventional processes to simplify the FSW. One of which is the development of stationary shoulder FSW. In this system, the probe is made to rotate while the tool's shoulder is kept stationary and it is in contact with the surface to keep a constant contact force. This method provides a better-quality surface finish of FSW and low distortion and heat dissipation (Backer and Jeroen, 2018.). The current development of robots has upgraded the FSW welding speed to 3 m/min, as well as a sheet of 7 mm can be welded with this technique. The robots used in friction stir welding can be split into two types. The first one is serial kinematics robots (SKR), and the second one is parallel kinematics robots (PKR). At industrial work, SKRs are widely utilized. This kind of robot consists of a set of serial links connected by motor actuated joints, often known as articulating arms. They typically have six degrees of freedom, allowing them to set the tool or controlled element in any position. FSW SKR offers greater flexibility, diversity, and cheaper investment costs (Backer and Jeroen, 2016). Some types of FSW SKRs are the ESAB Rosio, ABB IRB-6400, ABB IRB7600, and KUKA KR 1000 Titan, among others. However, there is a weak point which is the lack of rigidity, which results in a lack of loading

The use of a force control unit; including a force sensor that can measure the real force and feedback it as a referencing force to fix the input force, is a perfect option to deal with the problem (De Backer, 2014), (Smith, 2000), a barrier to widespread implementation of friction stir welding (FSW) (Mishra, 2018) and (Zimmer-chevret et. al., 2010).

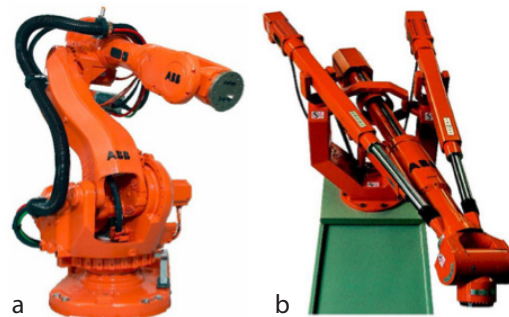

Figure 1. (a) SKR, (b) PKR, (De Backer, 2014).

For μ FSW CNC controllable micro-milling machines have been tuned for μ FSW at TWI since its invention. This could appear that using adaptive load control to preserve surface quality would be ideal for thin materials. In any case, outstanding results can be achieved without adaptive load management if the machine is strong enough and has a configurable offset for the vertical z-axis on the x-y workspace (Joo Teh et. al., 2011). KUKA is one of the companies that used the FSW robot for μ FSW of welding with a difference in the size and accuracy of the tool used and the vertical force. However, the use of robotic arm technology for μ FSW is very limited due to the lack of rigidity as the application demands high precision and accuracy.

2. RESEARCH CONTRIBUTION

In the modern world, robots have made human work more manageable. Today the utilization of robots is turning out to be more common than before. Robots have become one of the most significant parts used in mechanical industries due to their ease of control, adequate working space, and high precision since their introduction into the field of welding. There are no previous researches on the robots specialized in performing the micro friction stir welding. This article aims to design a 6-DOF robotic arm that must make the micro friction stir welding process viable. The design approach to obtain the goal is based upon selecting appropriate links lengths, revolute joints, the weight estimations, and the material of links along with the end effector (welding tool). The research would be beneficial for manufacturing a pre-designed μ FSW robotic arm, which can be used in industrial welding processes requiring high precision. In addition, this research will be helpful for researchers interested in industrial robots for welding by going over all previous scientific research and accurately summarizing the information related to precision welding, which saves them time and effort.

3. METHODOLOGY

The proposed system is the micro friction welding robotic arm for achieving the goals and objectives of micro friction welding. The main task of the following methodology is to design and analysis of the robotic arm, which is discussed by the following phases shown in Figure 2.

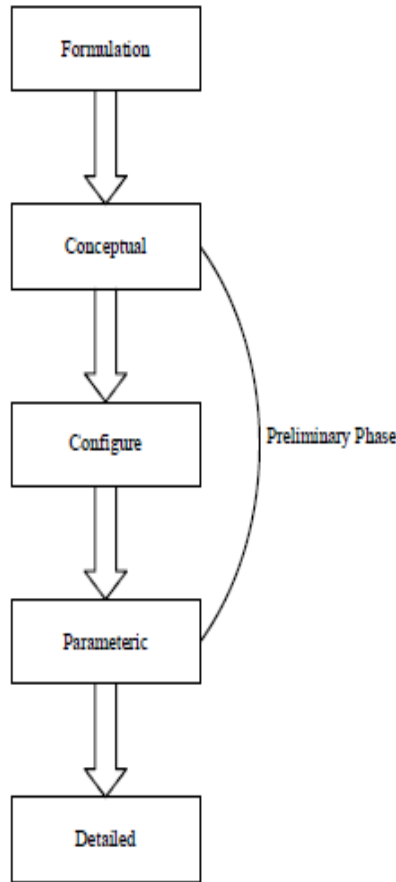

Figure 2. Methodology.

In the formulation phase, it will be decided how the complete design procedure will be taken and how its parameters will be adopted, which software will be used to design the novel robotic arm for the μ FSW purpose. The design of the arm will be on the SOLIDWORKS 3D modeling software according to the design parameters and dimensions. The conceptual phase decided the size factor of the robotic arm for friction welding purposes and described the needs of the design. At the start, choosing the unit of SOLIDWORKS is in meters, but according to design requirements and size of the design, it is decided to go for the MMGS parameters. The initial segment of the robotic arm is a kind of synergistic robot that takes after the development of a human arm. The second piece of the robotic arm is a fast-revolving motor with reasonable force to give proper erosion power to create miniature welding, which is joined to the instrument, the last piece of the robot. While in the configuration phase, the entire configuration is about designing components, specification for the components, and the last is about the analysis of the complete design. The operating direction of the design will be the six degrees of freedom, which will be a primary specialty of the design. The use of MD25 and MD32 servomotors will provide a strong base during the operating conditions of the design, and also the weight of the lower parts is also large

than the upper parts near the drilling motor. That is why the highly torqued motors are used in the design to provide the stability of the design system. In the elbow joint of the welding robotic arm, the MD17 motor is used because of the less weight of the parts and the quick response to the targeted axes. The servo motors are used in the friction welding robotic arm's waist, shoulder, and elbow. The descriptions of all these motors will be shown below in Table 1.

Table 1. The characteristics of motors in each joint.

Type	17series	25series	32series
Torque (related)	30Nm	85Nm	156Nm
peak torque	69Nm	200Nm	420Nm
max rotational speed	135°/s	135°/s	85°/s
Weight	3.95kg	8.90kg	16.55kg
Rotational angle	±360°		
voltage of supply	DC 48V		

The next phase is the parametric phase, which will describe the major dimensions of every part used in the robotic arm's design and assembly. In addition, the movements of the arm or the freedom degrees will be discussed and finalized. In this robotic arm for the micro friction welding, three types of motors are decided to be used there which are MD25, MD32, and MD17, whose dimensions are in series 110mm x 52mm x 25mm, 86mm x 45mm x 25mm and 70mm x 36mm x 21mm. These dimensions of the servomotors are much attractive in explaining the design of the current robotic arm. The degrees of freedom for that welding arm will be six; it can achieve maximum-targeted directions of movements. The last phase is the detailed design phase. It deals with the complete design procedure and the design of each component. The design of each component will be explained according to the design criteria. The main part in the micro friction welding process, a DC motor with a rotational speed of up to 10,000, is installed inside the cylindrical cage. This motor is 34B Series BLDC manufactured by Bodin Electric Company model 3317. The last part of the robot component is the tool that can be designed in different shapes and these shapes change depending on the type of welded metal. Three non-threaded tools can be made with various pin shapes when utilizing aluminum, such as stepping pin, flat pin, and curved pin. Each of the three pins has a height of (0.8 mm) an arch chambering with a radius of 0.35 mm. in this article, the tool's shape is a curved pin tool.

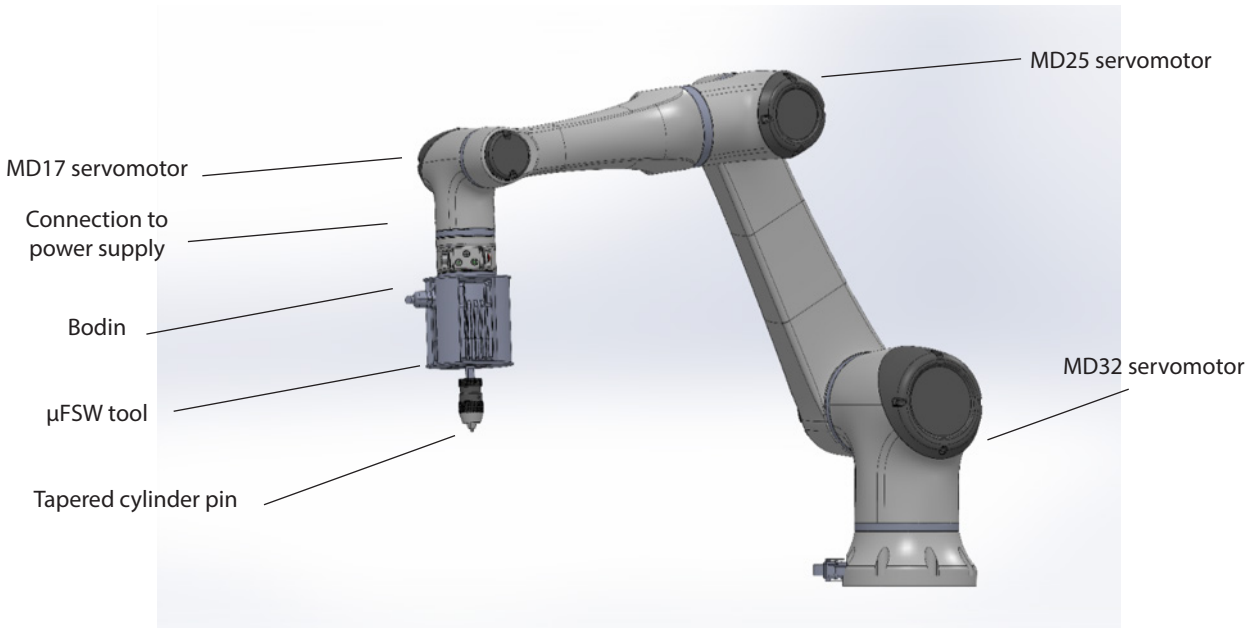

Figure 3. μFSW robot.

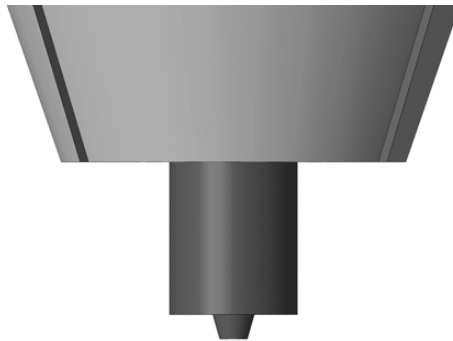

Figure 4. Curved pin tool.

After designing the model as per the proposed steps, the next step is to analyze the μFSW robot using ANSYS simulation software for structural engineering to determine the structural behaviors under different specifications, without building test products or conducting crash tests in reality.

4. RESULTS

4.1. μFSW Robot Analysis

At first, the arm was simplified and remodeled because of the complexity of the original design. The analysis was conducted on important parameters in principle work of the robot prank: (Rigid body dynamics, Stiffness verification, thermal and stress structural analysis on the tool and tip of the robotic

arm, and transient structural. Several steps must be performed to obtain results; these include pre-processing in which the geometry is imported: material Assignment, meshing, solver setup (Boundary conditions), and solutions. The results contours are obtained by selecting the solution we want to perform.

4.1.1 Rigid body dynamic

ANSYS Rigid Body Dynamics leads to a deep understanding of the motion and stability of mechanical systems earlier in the development cycle when informed engineering decisions are critical. So here the overall motion behavior of the robot arm is studied, the first pre-processed in the geometry seven components of the robot are selected as shown in Figure 5.

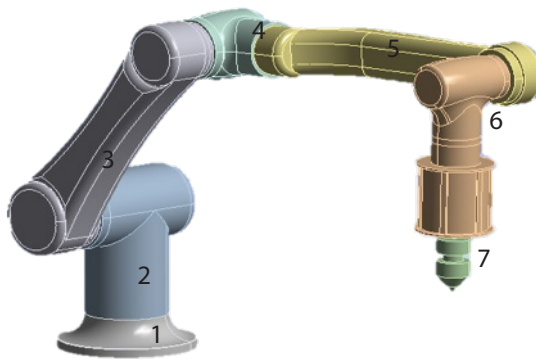
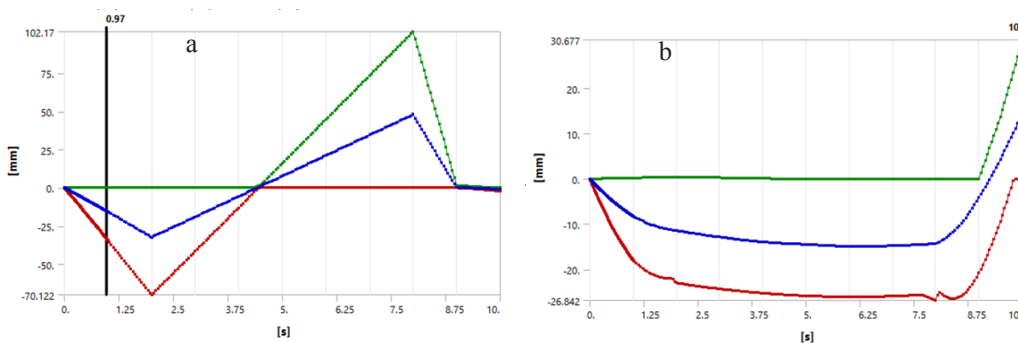

Figure 5. Robot components.

The rotational connection applied for: the base, the shoulder, the elbow and the motor joint. There will not be any meshing in this process since the rigid body dynamic does not require the meshing parameters because it is not fundamental to the FEA method, it just needed to get some basic factors to develop the designed structure. Have three boundary conditions, first in the base component, the second in the second servo of the robotic arm, and the last in the third servo motor. The result is shown in the solution part directional deformation in (x,y,z). The graphs of deformation development according to time steps are shown below.



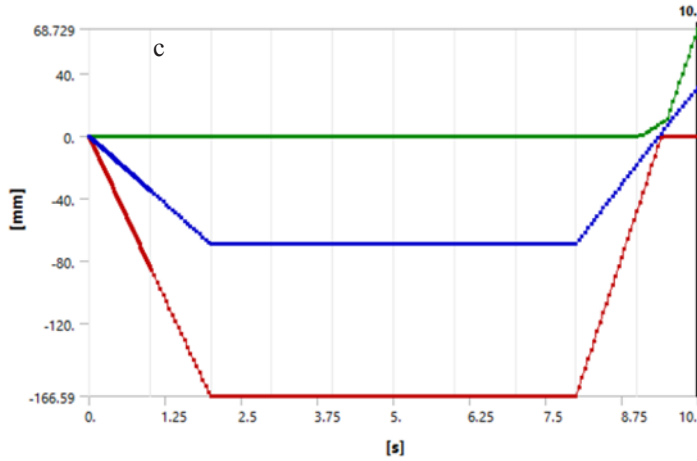

Figure 6. Deformation variation in (a) X-axis, (b) Y-axis (c) Z-axis with respect to time.

The graphs show the contour development of deformation in the structure of the micro friction welding robotic arm. In the x-direction there will be zero maximum deformation due to the applied loading conditions and the minimum deformation is also in the negative direction because the deformation is compressive. The deformation in the y-direction and z-direction is in the tensile form due to the maximum and minimum limits of the deformation. The illustration of visualizing the deformation development is also needed to check the deformation development smoothness in the structure under applied loading conditions.

Factor of safety in the design study is much important for getting the structure safety during the working environment. The von mises stresses generated in the structure will be approximately same but the deformation on different axis may vary. The factor of safety in the micro friction robotic arm according to the rigid body dynamic analysis mathematically can be represented as;

Safety factor (N) for the robot body is calculated as follows.

$$N = \frac{\text{Yield Strength of Aluminium alloy}}{\text{max. Von mises stress}} \quad (1)$$

$$N = \frac{280}{38.091} = 7.35$$

and the safety factor for the tool is calculated as follows.

$$N = \frac{\text{Yield Strength of titanium alloy}}{\text{max. Von mises stress}} \quad (2)$$

$$N = \frac{930}{38.091} = 24.41$$

4.1.2. Stiffness verification

This step aims to find the overall stiffness. Started with importing the robot model after the robot poses adjusted accompanied by setting contact parameters between components, which increases the time consumption. in this study the static structural will be used. All the processes in this part are the same as the previous one, the only change is in the geometry part that the third component will be flexible, not rigid and the mesh will be generated its type (tetrahedral- first order liner mesh)with patch conform algorithm having element size 8 mm. In the analysis, the setting will be four joint loads.

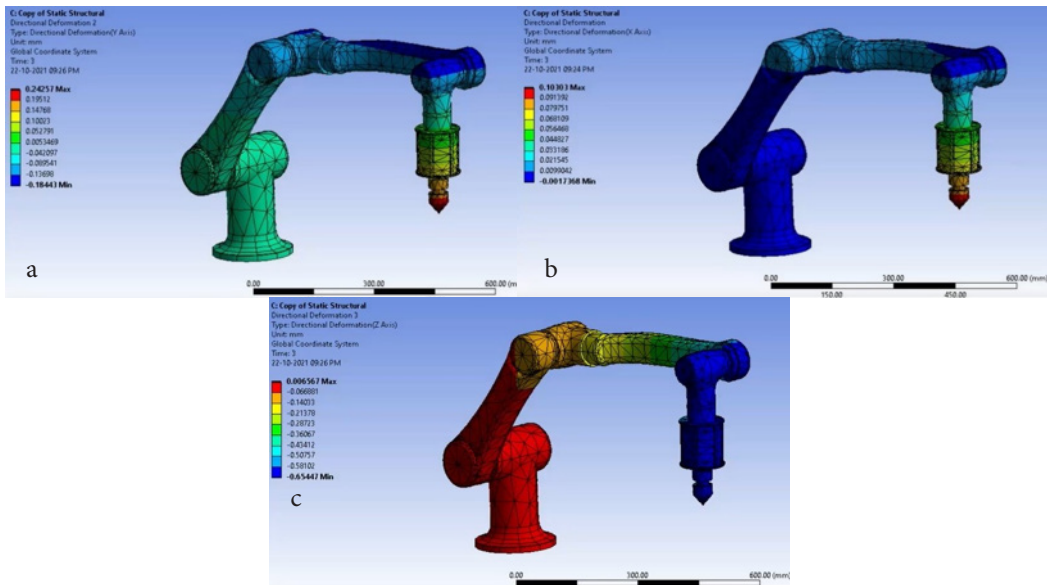

Figure 7. Directional deformation in the (a) X-axis (b) Y-axis (c) Z-axis.

To find the total stiffness of the robot the average value of directional deformation will be used but first, some update is done a new process is an upload with the same component and variable but in the analysis setting instead of joint, fixed support, and force was used. The force is 1000 N located in the tip in the direction of the welding process the table below shows the directional deformation in (x,y,z).

Table 2. The Directional deformation.

Axis	The average directional deformation
X	2.4273e ⁻⁰⁰²
Y	2.3938e ⁻⁰⁰²
Z	0.30015

To obtain the directional stiffness in the x-direction, an external force in the x-direction applied can be expressed as:

$$F_e = (1000,0,0)^T$$

The directional deformation in the X-axis result is shown in figure 7(a).

To obtain the directional stiffness in the Y direction, an external force in the Y direction is applied which can be expressed as:

$$F_e = (0,1000,0)^T$$

The result of directional deformation in the Y direction is shown in figure 7(b)

Moreover, the same thing in the z-direction to obtain the directional stiffness in the z-direction, an external force applied which can be expressed as:

$$F_e = (0,0,1000)^T$$

The directional deformation in the Z direction is shown in Figure 7(c).

The stiffness formula;

$$S = \frac{F}{\delta}$$

Where F is the applied force and δ is the deformation.

$$X_s = \frac{1000}{2.427e^{-002}} = 3044.146 \text{ N/m} = 3.044146 \text{ N/mm}$$

$$Y_s = \frac{1000}{2.3938e^{-002}} = 3086.7474 \text{ N/m} = 3086.7474 \text{ N/mm}$$

$$Z_s = \frac{1000}{0.30015} = 3331.6675 \text{ N/m} = 3.3316 \text{ N/mm}$$

4.1.3. Thermal effect and stress structural analysis on the tool and tip of the robotic arm

This part focuses only on the effectiveness of the tool component and its ability to handle the challenge of μ FSW. Two types of analyses are studied: steady-state thermal and static structure. For the first part, which started with importing the model, added the analysis parameter, such as the tool's material, then the mesh will be generated. The mesh type is foster mesh, the initial temperature is the room temperature, and two convection coefficients are added to the tool body and tip. The fine mesh is generated having an element size of 0.25 mm.

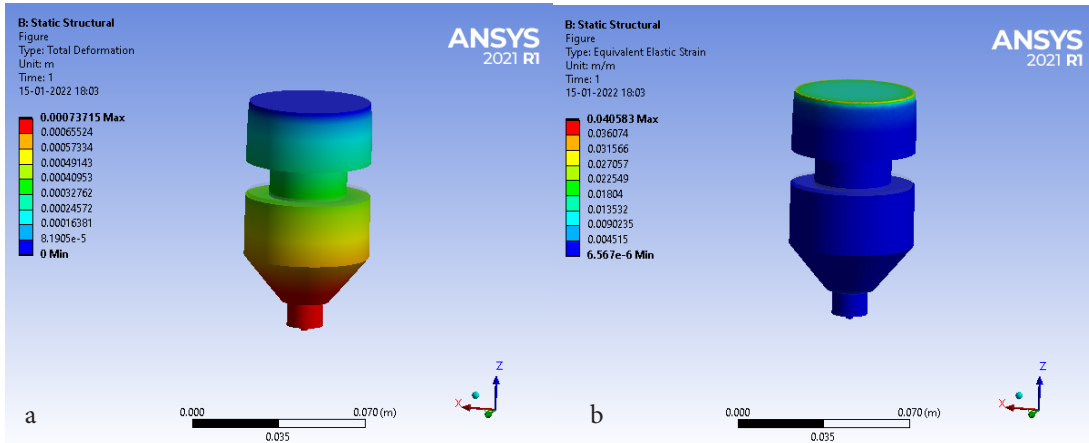

Figure 9. (a) Total deformation (b) Equivalent stresses on tool.

Figure 9 (a) shows total deformation indicates that while keeping the top surface of the holder fixed, deformation is observed on the tip, which is under an applied force. This also induces stress and strain in the holder as shown in Figure 9 (b).

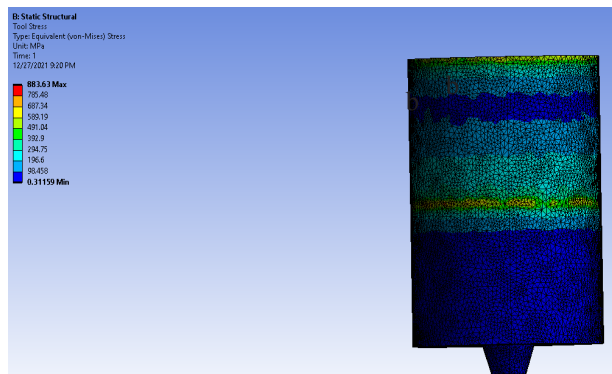

Figure 10. Total stress on the tool tip.

Also, in the tip shown in Figure 10, the maximum stress is on the top surface which is in contact with the holder; this means that this area is the most vulnerable to fracture since it is common to find failures that initiate from the regions that are closed to the fixed points.

The holder temperature simulation is shown below.

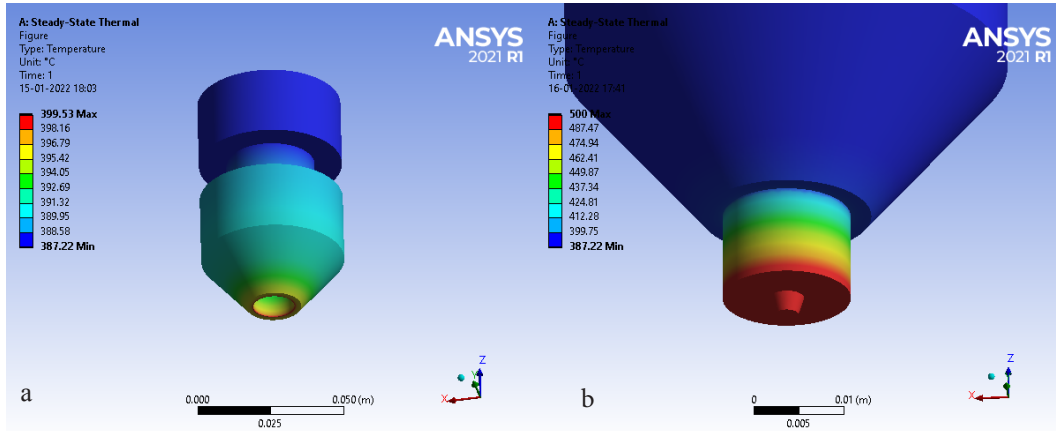

Figure 11. Temperature variation of (a) Holder (b) Tool tip.

The holder gets heated due to conduction from the tip; however, the maximum temperature of the holder is significantly less than the maximum temperature of the tip. As shown in Figure 11.

4.1.4. Transient structural

The transient analysis in the structural assemblies is much important because this process analyzes the deformation, stresses, and many other factors by providing the motion study in the simulation software by applying the time and step control settings. This process leads to a thorough grasp of the motion and stability of mechanical systems. The analysis is done in the frictional point, which means the robot body is not moving, so after the uploading of the robot geometry bonding connection is made between its parts, so they remind constantly. In the next step, the mesh was done; the used mesh is foster mesh with element size 8 mm. In total, the Statistics will be (nodes 55653, Element 30773). Three moments are applied to the first joint, the second, and the beginning of the arm. The moment varies with time. The boundary condition is added to the base of the arm, and a reaction force is added to the tip. In the last part, the result is accomplished, which is the equivalent stress and total deformation.

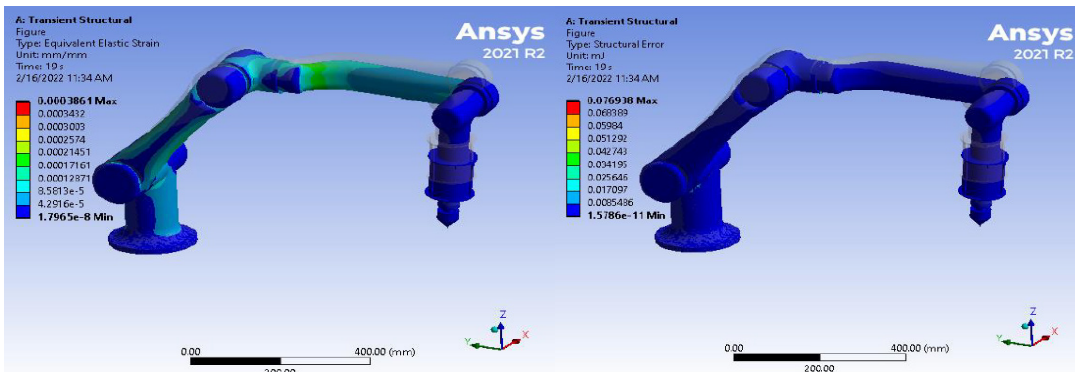

Figure 12. (a) Equivalent strain (b) Structural error

The contours of the equivalent strain are shown in figure 12 (a) indicate that the maximum strain is 0.0003861 mm/mm, which can be considered very safe since the yield strength for aluminium alloy is around 280 MPa. The given results are acceptable because the structural error shown in figure 12(b) is in orders of magnitude lower than the required criterion of 1 micron. The error is considerably greater near the joints, and that is understandable because those regions in specific are prone to stress concentration. It is common in engineering that failures are generally found at the joints. There is compressive stress, tensile stress in some regions, particularly in the lower parts of the robot body with compressive, and the tip mount with the tensile. However, it is not visible from the Von-Mises Stress, since the Von-Mises presents the absolute value of the stress at a certain point. The contour for von-Mises stress is shown below in Figure 13.

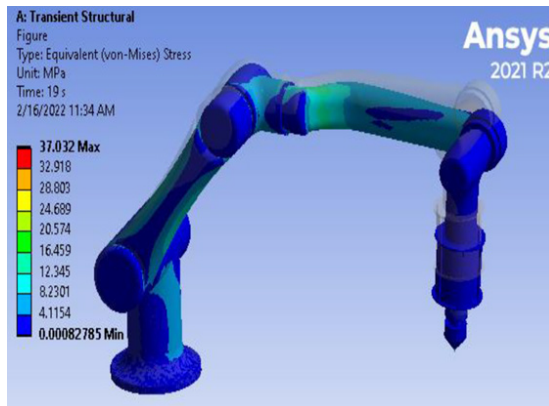

Figure 13. Equivalent stress

Force convergence development with the time is shown in Figure 14.

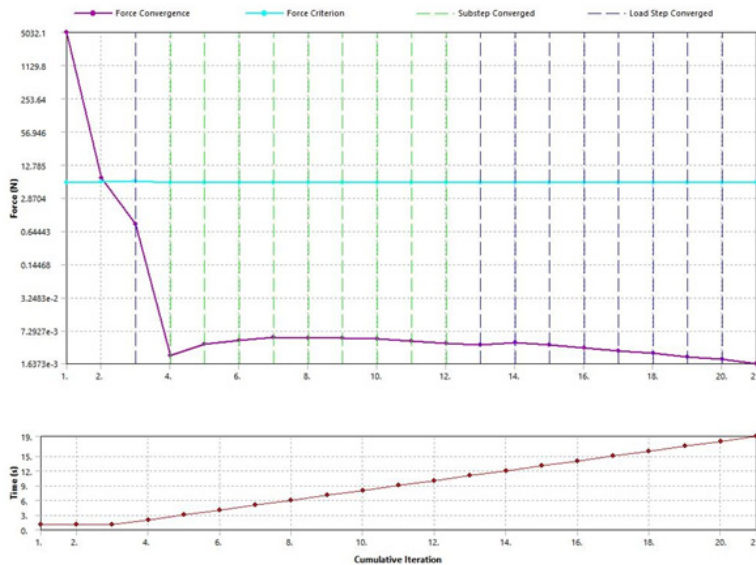

Figure 14. Force convergence in transient analysis.

Force convergence is related to the residual force, which is the difference between external and internal force. In graph 13 the force convergence is shown in the purple line, in the beginning of the process there is no internal force so it starts from it is maximum until it becomes below the blue line which is the force criterion line and that means the solution is valid and converged.

The factor of safety in each structure is the most important attribute to check the ability of that specified structure before making the real structure. For that, purpose the von-mises stresses according to the simulation software come under consideration. The maximum von-mises stresses in the structure will be the same under the applied conditions in the design with similar parameters. The yield strength of the aluminum alloy as mentioned before is 280 MPa and the titanium alloy is 930 MPa.

Thus, the safety factor (N) for the robot body can be calculated as follows:

$$N = \frac{280}{37.032} = 7.56$$

Safety factor (N) for the tool can be calculated as follows:

$$N = \frac{930}{37.032} = 25.11$$

The safety factor in two different types of structural analysis shows some separate results but without exceeding the amount of safety factor range. The safety factor of aluminum alloy and the titanium alloy in the transient structural study is more although both analyses have the same yield strength. However, the nature of transient structural analysis and the rigid body dynamic analysis is the same for checking the deformation and stresses in the structure. For structures according to the expert studies, the safety factor should minimum of 1.2 otherwise; below this limit, structure will be considered unsafe for work.

5. DISCUSSION

In this study, a portion of the attribute's parameters that affect μ FSW robotic to stand on the possibility of robot effectiveness in real-life are analyzed, yet before the utilization, it is mandatory to accomplish more tests or investigation on that arm. As per the experiment results and the simulation, the robot arm is completely satisfying the maximum distortion energy criterion, Von Mises criterion, and MSS (Maximum Shear Stress) theory. For the factor of safety in the structure according to the transient structural analysis on the robot body and the tool is shown in the safest region of working conditions.

6. CONCLUSION

This paper aims to design a robotic arm for micro friction stir welding. The research framework is built with background study regarding the friction stir welding and micro friction stir welding processes. The design parameters are determined at the beginning. A 6-DOF robot arm for micro friction stir welding is designed using SOLIDWORKS. The components and motor selections are inspired by companies working for assembly technology, where separate parts are collected from, and these parts are combined to design the robot with the appropriate size and weight, which is different from traditional robots used for friction stir welding.

The design is analyzed through ANSYS software. The robotic arm is analyzed using transient and deformation analysis, static structural and thermal effect, and stress structural analysis on the tool and tip of the robotic arm. The material selection, meshing, the boundary conditions are given in pre-processing steps. The analysis of the robotic arm and some of its properties depend on metals used for design. Aluminum alloys are used due to their many important properties such as ductility, strength, cost-effectiveness in this study. Titanium alloys are used in the pin's design, which directly contacts the workpiece for its hardness and high-temperature tolerance.

The above results show that this type of robotic arm can be pivotal due to its effectiveness under the studied analysis. It completely satisfies the maximum distortion energy criterion, Von Mises criterion, and MSS (Maximum Shear Stress) theory. However, in order to analyze the system more precisely and check its long-term effectiveness in operation, a more experimental study is needed for the proposed μ FSW robotic arm.

7. REFERENCES

Backer, D., and Jeroen. 2018. Stationary shoulder friction stir welding, TWI, available in: <https://www.twi-global.com/what-we-do/research-and-technology/technologies/welding-joining-and-cutting/friction-welding/friction-stir-welding/techniques/stationary-shoulder-friction-stir-welding>, last accessed May 12 2021.

Backer, D, and Jeroen. 2016. Robotic Friction Stir Welding , TWI, available in: <https://www.twi-global.com/what-we-do/research-and-technology/technologies/welding-joining-and-cutting/friction-welding/friction-stir-welding/techniques/robotic-friction-stir-welding>, last accessed May 12, 2021.

Bharat, P., R. Singh, and T. Campus. 2014. A Hand Book on Friction Stir Welding ,Late Shri Ram, Yagya Singh .

De Backer, J. 2014. "Feedback Control of Robotic Friction Stir Welding". Working Paper No 4-2014. University West, Trollhättan, Sweden.

Fersini, D., and A. Pirondi. 2007. Fatigue behaviour of Al2024-T3 friction stir welded lap joints, Engineering Fracture Mechanics, vol. 74, pp. 468–480.

Joo Teh, N., H. Goddin, and A. Whitaker. 2011. Developments in micro applications of friction stir welding, TWI, available in: <https://www.twi-global.com/technical-knowledge/published-papers/developments-in-micro-applications-of-friction-stir-welding>, last accessed May 12, 2021.

Mishra, A. 2018. Micro Friction Stir Welding Process: State of the Art, Int. J. Curr. Eng. Technol., vol. 8, pp. 02 .

Padhy, G.K., C.S. Wu, and S. Gao. 2018. Journal of Materials Science & Technology Friction stir based welding and processing technologies - processes , parameters , microstructures and applications: A review, vol. 34, pp. 1–38.

Salih, O.S., H. Ou, W. Sun, and D.G. McCartney. 2015. A review of friction stir welding of aluminium matrix composites, Materials and Design,vol,86, pp 61-71.

Scialpi, A., M. De Giorgi, and L.A.C. De Filippis. 2008. Materials & Design Mechanical analysis of ultra-thin friction stir welding joined sheets with dissimilar and similar materials, vol. 29, pp. 928–936.

Sen, M., S. Shankar, and S. Chattopadhyaya. 2019. Micro-friction stir welding (μ FSW)-A review, in Materials Today: Proceedings, vol. 27, pp. 2469–2473.

Smith, C. B. 2000. Robotic friction stir welding a standard industrial robot, in 2nd Frict. Stir Weld. Int Symp., available in: <http://www.frictionstirlink.com/publications/Pub062ndFWSymposiumFSWSTDINDRobotpdf.pdf>, last accessed May 25, 2021.

Zimmer-chevret, S., L. Langlois, J. Laye, J. Goussain, P. Martin, and R. Bigot. 2010. Qualification of a robotized Friction Stir Welding System - In: International conference on scientific and technical advances on friction stir welding and processing, available in: https://sam.ensam.eu/bitstream/handle/10985/8774/LCFC_FSWP_2010_ZIMMER-CHEVRET.pdf?sequence=1&isAllowed=y, last accessed May 25, 2021.