



International Electronic Journal of Environmental Education (IEJEE-Green) is an international refereed academic journal which publishes research papers on all aspects of environmental education. The aim of the journal is to provide a thoughtful forum for environmental researchers, practitioners and scholars to further the study and practice of environmental and sustainability education.

International Electronic Journal of Environmental Education is published two issues per year. IEJEE-Green provides immediate open access to its content on the principle that making research freely available to the public to support a greater global exchange of knowledge.

IEJEE-Green is listed and indexed in: ERIC, Environment Complete (EBSCO), Directory of Open Access Journals (DOAJ), Index Copernicus, NewJour, Turk Egitim Indeksi, ASOS Index and Google Scholar.

Publication of any material submitted by authors does not necessarily mean that the journal, publishers, editors, or any of the editorial board members endorse and suggest the content. Publishing decisions are based and given only on scholarly evaluations. Apart from that, decisions and responsibility for adopting or using partly or in whole any of the methods presented in IEJEE-Green pages solely depends on the readers' own judgment.

INTERNATIONAL ELECTRONIC JOURNAL OF
ENVIRONMENTAL EDUCATION
Vol. 6, Issue 2, January 2016

Editor

Sibel BALCI, *Aksaray University, Turkiye*

Berat AHİ, *Kastamonu University, Turkiye*

Editorial Board

Annette GOUGH, *RMIT University, Australia*

Ceren TEKKAYA, *Middle East Technical University, Turkiye*

Dan SIVEK, *University of Wisconsin, United States*

Elvan SAHIN, *Middle East Technical University, Turkiye*

Eva ALERBY, *Luleå University of Technology, Sweden*

Gaye TEKSOZ, *Middle East Technical University, Turkiye*

Gerald Robert CULEN, *University of Florida, United States*

Gillian KIDMAN, *Queensland University of Technology, Australia*

Hamide ERTEPINAR, *Istanbul Aydın University, Turkiye*

Jale CAKIROGLU, *Middle East Technical University, Turkiye*

Joe E. HEIMLICH, *Ohio State University, United States*

John LIDSTONE, *Queensland University of Technology, Australia*

Joseph STOLTMAN, *Western Michigan University, United States*

Laura BARRAZA, *Deakin University, Australia*

Marcia MCKENZIE, *University of Saskatchewan, Canada*

Malgorzata GRODZINSKA-JURCZAK, *Jagiellonian University, Poland*

Milan KUBIATKO, *Masaryk University, Czech Republic*

Mehmet ERDOGAN, *Akdeniz University, Turkiye*

Ozgul YILMAZ TUZUN, *Middle East Technical University, Turkiye*

Paul HART, *University of Regina, Canada*

Pavol PROKOP, *Trnava University, Slovakia*

Philip C. SHORT, *CISDE BTHS East, United States*

Thomas J. MARCINKOWSKI, *Florida Institute of Technology, United States*

Editorial Assistants

Abdulkadir KARACI, *Kastamonu University, Turkiye*

Sevcan CANDAN, *Kastamonu University, Turkiye*

© International Electronic Journal of Environmental Education, 2016.

Apart from individual use, no part of this publication may be reproduced or stored in any form by any means of without prior written permission from the publisher.

ISSN: 2146-0329

www.ijeegreen.com

Table of Contents

The Awareness of Turkish High School Students About Carbon Footprint and the Effects of the High School Biology Curriculum on this Awareness <i>Serap OZ-AYDIN</i>	29-53
The Impact of Affective Constraints on Shaping Environmental Literacy: Model Testing Using Mediator and Moderator Variables <i>Nilay OZTURK & Gaye TEKSOZ</i>	54-75
The Determination of Cognitive Structure of Candidate Teachers About Energy Centrals Kadir KARATEKIN, Ersin TOPCU & Bahattin AYDINLI	76-91
Environmental Literacy in Madeira Island (Portugal): The Influence of Demographic Variables <i>Héider SPINOLA</i>	92-107
The Effect of Active Learning Based Science Camp Activities on Primary School Students' Opinions Towards Scientific Knowledge and Scientific Process Skills <i>Meryem Nur AYDEDE YALCIN</i>	108-125
Effect of Environmental Education Based on Transformational Learning Theory on Perceptions towards Environmental Problems and Permanency of Learning <i>Gökhan UYANIK</i>	126-140
An Assessment of Turkish Elementary Teachers in the Context of Education for Sustainable Development <i>Ali SAGDIC & Elvan SAHIN</i>	141-155

The Impact of Affective Constraints on Shaping Environmental Literacy: Model Testing Using Mediator and Moderator Variables

Nilay ÖZTÜRK*

Middle East Technical University

Gaye TEKSÖZ

Middle East Technical University

To cite this article: Öztürk, N. & Teksöz, G. (2016). The impact of affective constraints on shaping environmental literacy: Model testing using mediator and moderator variables. *International Electronic Journal of Environmental Education*, 6(2), 54-75.

Abstract

The aims of this study were; first to investigate the mediating effects of pre-service teachers' (PTs) attitude toward environment on the relationship between their environmental concern and environmental responsibility, and second, to explore the moderating effect of gender on the relationships between; PTs' environmental concern and responsibility; and environmental attitude and responsibility. A total of 1626 PTs completed the Environmental Literacy Survey. The findings revealed that PTs' attitude had a significant mediating effect on the relationships between environmental concern and responsibility. Furthermore, the results of the moderation analysis showed that the relationships did not differ in female and male participants.

Key words: Environmental literacy, attitude, responsibility, gender, mediation, moderation.

Introduction

Our attempt with this research is to explore the mediating effect of attitude toward environment on the relationship between environmental concern and environmental responsibility. Besides, we attempted to reveal the moderating effect of gender on the relationship between environmental concern and environmental responsibility and the moderating effect of gender on the relationships between attitude toward environment and environmental responsibility. What brought us to investigate the relation among these environmental literacy dimensions through mediation and moderation analysis however is the inconsistency related to the impact of attitude on the other components of environmental literacy (EL). Therefore in the following section we have put our reasonings forward in relation with the history of EL research, than we presented the results obtained by the use of one of the novel approach (mediation and moderation analysis). Therefore the context of this research is to propose a new insight to EL literature for attempting to explore the relationships between affective components of EL (environmental concern, responsibility, attitude) as well as the effect of gender on these relationships by model testing using mediator and moderator analysis thus to invigorate one of the inconsistent areas of EL research.

The concept of environmental literacy was first defined by Roth in an article for Massachusetts Audebon (1968). He was replying "to the then frequent media references to environmental illiterates who were responsible for polluting the

environment” (Roth, 1992 p. 7). Roth then asked the question, “how shall we know the environmentally literate citizen?” (p. 7), which became the starting point for discussion and the development of the concept. Although concern about the environment has substantially developed since then and now refers to much more than pollution, developing environmental literacy remains the primary goal of environmental education.

In the early days, the Tbilisi declaration (UNESCO-UNEP, 1977) was important in marking the beginning of the idea of environmental education and opened the way for definitions of environmental literacy. In 1980, Hungerford, Peyton, and Wilke (1980) defined the environmentally literate as having positive attitudes, strong sense of responsibility as well as knowledge on issues and action strategies. In their announcement of the 1990 as the International Environmental Literacy Year, the United Nations offered a broad definition of environmental literacy (UNESCO-UNEP, 1989). During the 1990s, environmental literacy was refined by Marcinkowski (1991), who expanded on the definition in the Tbilisi declaration. Subsequently, Roth (1992) defined environmental literacy as having the four strands of; knowledge, skills, affect (sensitivity, attitude and values) and behaviour (personal investment, responsibility, active involvement). Moreover, he emphasized the unique feature of environmental literacy in that it goes beyond the cognitive skills, involving thinking, acting and valuing. Furthermore, declaring that there is variation in people’s development of environmental literacy Roth (1992) determined that there were three levels of environmental literacy; namely, nominal, functional and operational, in each of which there are the stages of awareness, concern, understanding and action. Roth (1992) also emphasized that capability at a particular developmental stage should not be confused with the achievement of the operational literacy itself. As he wrote, “a person who is environmentally aware is not necessarily environmentally literate; nor is a person who possesses broad environmental understanding; nor is one who demonstrates great environmental concern; nor necessarily is one who takes action on environmental issues” (p. 27).

Stables and Bishop (2001), on the other hand, argued that references to environmental literacy in the environmental education literature do not refer to fundamental debates about literacy. According to the authors, the justification for using the term in the way that it appears in those references remains limited due to existing notions of environmental literacy having a lack of grounding in the literacy debate outside environmental education. Therefore, Stables and Bishop consider the environment as the text and they make distinctions between strong (taking a broad view of literacy and acknowledging its full ramifications with environmental education) and weak (inconsistent with the field of environmental education) conceptions of environmental literacy. Accepting the environment as the text, however, brings authors to the point that, “we do not merely understand our environment scientifically, or in terms of one scientific approach, but ‘read’ it historically, aesthetically, and so on” (p. 93). Yet, according to the authors, “there are many ‘correct’ or different ways of understanding the environment” (p. 93). Thus, beginning from the end of the 20th century, the debate related to environmental literacy has continued concerning the relationships between the components of attitudes, knowledge and responsible environmental behaviour (Arnon, Orion, & Carmi, 2014; Cheng & So, 2015; Erdogan & Ok, 2011; Esa, 2010; Goldman, Assaraf, & Shaharabani, 2013; Goldman, Yavetz, & Pe’er, 2006; Hsu, 2004; Hsu & Roth, 1998; Hsu & Roth, 1999; McBeth, Trudi, & Volk, 2009; Pe’er, Goldman, & Yavetz, 2007; Shephard et al., 2014; Author, 2013; Yavetz, Goldman, & Pe’er, 2009). In other words, the debate that was about the definition of the environmental literacy in the 1990s now focuses on the relationships among the components that explain the achievement of overall operational environmental literacy.

In the related literature, the target has moved to the changes occurring in the components themselves and the relationship between the components over time and with and without exposure to environmental education (Pe'er, Goldman, & Yavetz, 2007). According to a considerable amount of research, increasing an individual's environmental knowledge results in more positive attitudes toward the environment (Bradley, Waliczek, & Zajicek, 1999; McMillan, Wright, & Beazley, 2004). However, the relationship between the cognitive components, affective components and behaviour maintain their complexity. Therefore, we still adhere to the claim made by Hungerford and Volk in 1990 that knowledge, as a critical component of environmental literacy, is not on its own, a sufficient precursor for environmentally responsible behaviour. The affective components are necessary for the transfer of knowledge into responsible environmental behaviour and are important for the development environmental literacy.

The background for the current debate related to the relationships among the components of environmental literacy relies upon Roth's (1992) claim given above. He stated that in terms of the stages of environmental literacy capability at a particular developmental stage should not be confused with achievement of operational literacy itself. This raises the question of what the most predominant component that determines operational environmental literacy is and whether there is a key component of environmental literacy that would allow us define a person as inevitably environmentally literate.

In a study that explores the barriers to pro-environmental behaviour, Kollmuss and Agyeman (2002) proposed a model for pro-environmental behaviour. Their model displayed how the different factors influence each other and pro-environmental behaviour and that most of the factors are self-explanatory. As well as reporting that the greatest positive influence on pro-environmental behaviour is achieved when internal and external factors act synergistically, the authors reported that environmental knowledge, values, and attitudes, together with emotional involvement make up a complex which is called 'pro-environmental consciousness'. Likewise, Tsevreni (2011) presented an alternative approach to environmental education that focuses on children's ideas and action rather than scientific knowledge.

The tendency of environmental educators to focus on emotion rather than scientific knowledge has echoes of Gardner's multiple intelligence theory (1999) and his attitude towards understanding:

I want my children to understand the world, but not just because the world is fascinating and the human mind is curious. I want them to understand it so that they will be positioned to make it a better place. Knowledge is not the same as morality, but we need to understand if we are to avoid past mistakes and move in productive directions. An important part of that understanding is, knowing who we are and what we can do... Ultimately, we must synthesize our understandings for ourselves. The performance of understanding that try matters are the ones we carry out as human beings in an imperfect world which we can affect for good or for ill (p. 180-181).

The reason behind such a discussion is beyond the scientific curiosity; it is related to the search for more effective environmental education and the development of environmentally literate future generations. Five decades have passed since Roth posed the question ("how shall we know the environmentally literate citizen?"), but it appears that there is not sufficient progress in increasing our knowledge of the environment. Furthermore, there needs to be an assessment of how environmental education has developed in line with the important global problems which were described by the UN Millennium goals in 2000 which include; poverty, hunger, primary education, gender equality, child mortality, and environmental sustainability. Therefore, environmental education as a source of knowledge needs regenerating by strengthening the concept of environmental literacy.

The way to remedy environmental education may come from the following three assertions as given above: 1. Different people are drawn to different semiotic systems (Gardner, 1999). 2. Capability at a particular developmental stage should not be confused with the achievement of the operational literacy itself (Roth, 1992) 3. We do not merely understand our environment scientifically or in terms of one scientific approach, but “read” it historically, aesthetically, and so on. Thus, there are many “correct” or different ways of understanding the environment (Stables & Bishop, 2001). We have inferred that what these three statements appear to have in common is the affective components of environmental literacy, and this may be the key that can allow us to define a person as inevitably environmentally literate.

Moreover, the above-mentioned claims lead us to focus on environmental attitudes that have been defined as a psychological tendency expressed by evaluating the natural environment with some degree of favour or disfavour (Milfont & Duckitt, 2010). Attitudes apply to general feelings toward ecology and the environment, feelings and concern for specific environmental issues and feelings towards acting to remedy environmental problems. Pro-environmental attitudes rise and fall with current events and vary with age, gender, socioeconomic status, nation, urban-rural residence, religion, politics, values, personality, experience, education, and environmental knowledge. Therefore, environmental attitudes are important because they often, but not always, determine behaviour that either increases or decreases environmental quality.

One of the scales to measure environmental attitudes is the New Environmental Paradigm (NEP) developed by Dunlap and Van Liere (1978) and that was later revised as the New Ecological Paradigm Scale (Cordano, Welcomer, & Scherer, 2003; Dunlap, Van Liere, Mertig, & Jones, 2000). Providing a tool for evaluating an individual’s environmental orientation, NEP represents an ecocentric worldview and allows researchers to assess an individual’s environmental orientation on a continuum from ecocentrism to anthropocentrism.

From the literature search, we have hypothesized that the key component of environmental literacy which allows us to define a person as inevitably environmentally literate may be related to affective components, and for our study, we defined the affective components as; environmental attitudes, concern and responsibility.

It is evident from the environmental education literature that there is a relationship between environmental concern and responsibility; however, we need to explore the mechanism(s) through which an effect operates and how its boundary conditions or contingencies are established. Therefore, posing questions of “how” and “when” may result in a deeper understanding of these components of environmental literacy, thus leading us define a person’s environmentally literacy (Hayes, 2012). Accordingly, our purpose was to explore the effect of attitude on the other affective dimensions of environmental literacy namely; environmental concern and responsibility.

To explore the effects of attitude toward environment on the relationship between environmental concern and environmental responsibility we used the mediation analysis as proposed by Hayes (2013). In addition, we used moderation analysis to determine the effect of gender on the relationship between environmental concern and environmental responsibility, and the effect of gender on the relationship between the attitude towards environment and environmental responsibility. In environmental education literature, gender has generally been evaluated as being implicated in the relation between the value orientations and behaviour. For example; Stern, Dietz, and Kalof (1993) reported that women have stronger beliefs than men about consequences for self, others, and the biosphere.

Similarly, the research undertaken by Bord and O'Conner (1997) showed that differences in perceived vulnerability to risk explain the gender gap found in environmental surveys and other areas of potential risk. As a result, they reported that, in response to every question in the survey that involves reactions to a specific risk, women were more concerned than men; however, in terms of health-risk perceptions of environmental concerns, the gender gap disappeared.

Moreover, research on environmental concern has consistently found that women have modestly stronger pro-environmental values, beliefs, and attitudes than men. Xiao and McCright (2015) used a structural equation modelling technique on General Social Survey data in the US from 2000 and 2010, and found that women report greater pro-environmental views and concern about environmental problems than men.

We chose pre-service teachers (PTs) as the sample because as key people in environmental education, PTs are the preliminary target population in attempts to explore the means of developing the knowledge and practice through more effective environmental education.

The main purposes of the present study are; first to investigate the mediating effects of PTs' attitude toward environment on the relationship between their environmental concern and environmental responsibility. Second, we attempted to reveal the moderating effect of gender on the relationships between PTs' environmental concern and environmental responsibility; and the moderating effect of gender on the relationships between attitude toward environment and environmental responsibility. To this end, our research questions (RQ) were:

RQ.1. What is the mediating effect of the PTs' attitude toward environment on the relationship between their environmental concern and environmental responsibility?

RQ.2. What is the moderating effect of gender on the relationship between the PTs' environmental concern and environmental responsibility?

RQ.3. What is the moderating effect of gender on the relationship between the PTs' attitude toward environment and environmental responsibility?

Methodology

Research Design

The design of the study was based on survey and correlational research. In survey research, certain aspects or characteristics of a group of people are investigated asking them a list of questions (Frankel & Wallen, 2006). Since one of the main purposes of the present study was to reveal the environmental literacy of PTs enrolled in the faculty of education, we chose to use the survey research design. The other research design used in the present study was the correlational research design. In this design, a combination of moderation and mediation analysis was utilized (Hayes, 2013).

Moderation occurs when the relationship between two variables depends on a third variable, called the moderator variable. This third variable is characterized as an interaction. In the correlational analysis framework, a moderator is the third variable that affects the zero-order correlation between an independent and a dependent variable. The moderation analysis aims to answer the questions related to 'when'. In the present study, the moderation analysis was used to determine the effect of gender on the relationships between PTs' environmental concern and environmental

responsibility, and between PTs' attitude toward environment and environmental responsibility.

A mediation model also uses a third explanatory variable, called the mediator variable, to identify and explicate the mechanisms or processes underlying a relationship between an independent and a dependent variable. Mediating relationships occur when the third variable plays an important role in governing a relationship between the two other variables. The mediation analysis focuses on answering the questions related to 'how'. In the present study, the mediation analysis was used to explore the effect of PTs' attitude toward environment on the relationship between their environmental concern and environmental responsibility.

Sample

The participants of this study were 1626 PTs enrolled in the school of education of a university located in Anatolia Region (Kırşehir province) in Turkey. Almost 70 % of the PTs were from the departments of Computer Education and Instructional Technologies, Elementary Education, Turkish Language Education and Social Sciences Education. However the rest were from the Departments of Science Education (16.1%), Mathematics Education (6.6%) and Early Childhood Education (8.5). Thirty percent of the participants were male and 70% were female with the average age of 20.3 years.

Instrument

The instrument used in the study was the Environmental Literacy Survey (Kaplowitz & Levine, 2005). The original survey consists of four main categories with distinct sets of questions concerning knowledge, environmental attitude, responsibility, and concern. However, in the present study, the last three components were utilized. Using these components, the respondents' environmental attitudes (10 items), responsibility (19 items), and concern (9 items) were investigated using a 5-point Likert-type scale. To measure PTs' attitudes and values related to the environment, the environmental attitude items were adapted to the present study from the New Ecological Paradigm Scale (NEP) (Dunlap, Liere, Mertig, & Jones, 2000). The environmental responsibility items measured PTs' perceptions about their responsibility to take part in pro-environmental actions. Finally, the environmental concern items revealed PTs' sensitivity and level of concern related to certain environmental problems and issues. In addition to these items, ten demographic questions were asked to determine the respondents' self-evaluation of their environmental background and obtain personal information; such as age, grade level, department, gender, and parents' level of education.

The instrument was originally developed in English, and previously translated and adapted to Turkish by Author (2009). In their study, the Turkish version of the questionnaire was peer-reviewed by three experts in the field of science education and one expert in the field of environmental science and some revisions were made. The Turkish version of the questionnaire was pilot-tested and its validity has been confirmed by Author (2009). The authors used the Cronbach alpha and found the internal consistency of the environmental attitude, responsibility, and concern dimensions to be 0.64, 0.80, and 0.88, respectively. In the present study, the internal consistency was also assessed using the Cronbach's alpha and found to be 0.56, 0.77, and 0.85 for the attitude, responsibility and concern item sets, respectively. In order to ensure the construct validity, the researchers also carried out a confirmatory factor analysis using AMOS 21. The results indicated a good fit, proved with high fit indices

(RMR= 0.052; GFI= 0.89; RMSEA= 0.051). Since they did not load to the factors significantly, one item related to attitude; namely “The Earth has plenty of natural resources if we just learn how to develop them” and one responsibility item, “Landowners should be allowed to drain wetlands for agricultural or industrial uses”, were omitted.

Data Collection and Analysis

Data collection was carried out during the fall of 2013. One of the authors of the study collected the data from PTs in all classrooms. The consistency of data collection was ensured by following the same procedure in all classrooms. The participation was voluntary and ethical commission permissions were taken prior to the data collection process.

The survey data was quantitatively analysed. Following the descriptive analyses, the mediation analysis was used to reveal the mediating effect of PTs’ attitude toward environment on the relationship between their environmental concern and environmental responsibility. Then, the moderation analysis was conducted to examine the moderating effect of gender on the relationships; between PTs’ environmental concern and environmental responsibility; and between PTs’ attitude toward environment and environmental responsibility. A statistical tool called PROCESS (Hayes, 2012) was used to conduct both the mediation and moderation analyses. Most statistical software does not allow modern moderation and mediation analyses to be conducted in a straightforward way. PROCESS, however, is a versatile modelling tool for SPSS that combines many of the functions of popular procedures and tools (such as SOBEL and INDIRECT) in one simple-to-use procedure.

Findings

We present the results in four sections, in accordance with our research questions: 1. PTs’ self-evaluations about environmental problems; 2. General characteristics of PTs’ environmental literacy; 3. Mediating effects of attitude toward environment on the relationship between environmental concern and environmental responsibility; 4. Moderating effect of gender on the relationships between environmental concern and environmental responsibility, and between attitude and responsibility.

Pre-service Teachers’ Self-evaluations on Their Perceptions Related to Environmental Problems

Participants were asked four questions to evaluate their environmental background about their perceptions regarding environmental problems/issues. As presented in Table 1, 55.2% of Turkish PTs stated that they have a fair amount of environmental concern and 49.4% reported their degree of knowledge about environmental issues and problems to be “only a little”. In addition, 65% of the participants reported environment as the second or most important problem faced globally. In this study, nearly half of the Turkish PTs (48.5%) stated that their childhood and the environmental behaviours of their parents had an influence on their perceptions about environmental problems.

Table 1.

Participants' self evaluation on their environmental background

<i>Item</i>	<i>Agreement (%)</i>
<i>Perceptions on concern about environmental problems</i>	
A lot	5.7
A fair amount	55.2
A little	34.5
Only a little	3.7
Not at all	1.0
<i>Perceptions about the importance of the environmental problems</i>	
Environment as one of the 2 or 3 most important problems	65.0
Environment as an important problem with several more important ones	31.7
Environment as an unimportant problem	1.1
Environment as not a problem	2.2
<i>Perceptions about the degree of knowledge about environmental issues and problems</i>	
A lot	2.1
A fair amount	47.3
Only a little	49.4
Practically nothing	0.6
Don't know	0.6
<i>Do you think your childhood and parents' environmental behaviors have an influence on your perceptions about environmental problems now?</i>	
Yes	48.5
Maybe	33.1
No	11.6
No idea	6.8

Pre-service Teachers' Environmental Literacy in terms of Attitude, Concern and Responsibility

Environmental attitudes. The mean score of Turkish PTs concerning the environmental attitude items was 3.83 out of 5 (SD=1.06). The highest mean score was found to be 4.59 for the item, "Plants and animals have as much right as humans to exist". The lowest mean, on the other hand, was 3.18 that was obtained from the responses to the item, "The balance of nature is strong enough to cope with the impacts of modern industrial nations". Furthermore, this item received the highest frequency (30.9%) among the "undecided" responses, followed by the item, "We are approaching the limit of the number of people the earth can support" (26 %). Therefore, although the M value for the attitude dimension of the Environmental Literacy Survey was reasonably high, the above-mentioned results related to the "undecided" responses indicate that PTs have quite uncertain positions related to the relationship between human beings and environment (Table 2).

Table 2.

Percentage of respondent agreement with environmental attitude items

<i>Item</i>	<i>Frequency (%)</i>			<i>M</i>	<i>S.D.</i>
	<i>Agree</i>	<i>Undecided</i>	<i>Disagree</i>		
We are approaching the limit of the number of people the earth can support.	59.5	26.0	14.5	3.63	1.03
When humans interfere with nature it often produces disastrous consequences.	64.6	19.4	16.0	3.72	1.07
Plants and animals have as much right as humans to exist.	92.6	2.4	5.1	4.59	0.89
The balance of nature is strong enough to cope with the impacts of modern industrial nations.	40.7	30.9	28.4	3.18	1.16
Despite our special abilities humans are still subjects to the laws of nature.	58.2	22.5	19.2	3.53	1.14
The so-called "ecological crisis" facing humankind has been greatly exaggerated.	62.3	23.7	14.0	3.69	1.06
Humans were meant to rule over the rest of nature.	69.2	11.7	19.0	3.81	1.23
Humans will eventually learn enough about how nature works to be able to control it.	80.5	11.1	8.4	4.08	0.99
If things continue on their present course, we will soon experience a major ecological catastrophe.	84.9	8.7	6.5	4.27	0.97
Average	68.0	17.3	14.5	3.83	1.06

Environmental responsibility. For the environmental responsibility items, Turkish PTs scored, on average, 3.97 out of 5. Nearly all the participants agreed to the item, "It is important that everyone be aware of environmental problems" with a mean score of 4.60 and the agreement percentage of 94.8 (Table 3). The next item was "All plants and animals play an important role in the environment", which is similar to the attitude item, "Plants and animals have as much right as humans to exist" that also received the highest mean value. Similarly, the items that consider only human (or non-human) received the highest frequencies of all; for example, "Government should pass laws to make recycling mandatory" (M=4.46); and "Collective action (i.e. movements) is central to solving environmental problems" (M=4.38). However, items that include both human and non-human interrelationships received the lowest frequencies, as in the following items; "Wild animals that provide meat for people are the most important species to protect" (M=3.24) and "Landowners should be allowed to drain wetlands for agricultural or industrial uses" (M=2.68).

Table 3.

Percentage of respondent agreement with environmental attitude items

<i>Item</i>	<i>Frequency (%)</i>			<i>M</i>	<i>S.D.</i>
	<i>Agree</i>	<i>Undecided</i>	<i>Disagree</i>		
We are approaching the limit of the number of people the earth can support.	59.5	26.0	14.5	3.63	1.03
When humans interfere with nature it often produces disastrous consequences.	64.6	19.4	16.0	3.72	1.07
Plants and animals have as much right as humans to exist.	92.6	2.4	5.1	4.59	0.89
The balance of nature is strong enough to cope with the impacts of modern industrial nations.	40.7	30.9	28.4	3.18	1.16
Despite our special abilities humans are still subjects to the laws of nature.	58.2	22.5	19.2	3.53	1.14
The so-called "ecological crisis" facing humankind has been greatly exaggerated.	62.3	23.7	14.0	3.69	1.06
Humans were meant to rule over the rest of nature.	69.2	11.7	19.0	3.81	1.23
Humans will eventually learn enough about how nature works to be able to control it.	80.5	11.1	8.4	4.08	0.99
If things continue on their present course, we will soon experience a major ecological catastrophe.	84.9	8.7	6.5	4.27	0.97
Average	68.0	17.3	14.5	3.83	1.06

Environmental concern. Among the given environmental problems, Turkish PTs were found to have the highest concern for 'water shortage' and 'poor drinking water quality' with the mean scores of 4.26 and 4.25, respectively (Table 4).

Table 4.

Percentage of participants' responses on environmental concern items

<i>Item</i>	<i>Not concerned</i>	<i>A little concerned</i>	<i>Undecided</i>	<i>Somewhat concerned</i>	<i>Very concerned</i>	<i>M</i>	<i>S.D.</i>
Air pollution	3.1	13.7	7.1	58.4	17.8	3.74	1.00
Water pollution	2.0	10.3	7.6	53.4	26.8	3.93	0.96
Automobile emissions	10.7	17.8	17.6	39.5	14.4	3.29	1.22
Industrial wastes	12.2	19.7	17.5	36.3	14.3	3.21	1.25
Hazardous wastes	9.4	16.1	13.4	37.9	23.2	3.49	1.26
Poor drinking-water quality	2.4	6.5	6.3	33.1	51.7	4.25	0.99
Water shortage	2.0	6.3	6.2	34.6	50.9	4.26	0.96
Ozone layer depletion	7.9	16.1	13.2	40.7	22.1	3.53	1.22
Climate change	5.1	13.4	13.8	42.2	25.5	3.70	1.14
Average	6.08	13.3	11.4	41.7	27.4	3.71	1.11

In terms of the results on the descriptive statistics, PTs in this study had positive environmental attitudes and responsibilities when human and environment were separately considered; however, they were undecided when there was a case of interrelation between human and nature.

PTs environmental concern was only regarding the problems of national concern. Water shortage and drinking water quality have currently been on the agenda of Turkey due to the less rainfall compared to past years which is considered to be one of the impacts of climate change. However, the results showed that PTs in this study did not perceive global problems as the results of or reasons for the national problems.

The results of the descriptive analysis, therefore, possess the characteristic of PTs environmental literacy that there may be an additional interrelation/s between environmental attitudes, responsibility and concern, which can further explain the above-mentioned attitudes toward environment.

The Mediating Effect of Attitude toward Environment on the Relationship between Environmental Concern and Environmental Responsibility

As mentioned before, one of the purposes of the present study was to investigate the mediating effects of attitude toward environment on the relationship between environmental concern and environmental responsibility. Before proceeding with the mediation analysis, the Pearson correlation coefficients among the variables were calculated and given in the Table 5 below.

Table 5.

Pearson correlations and reliability of the variables

Variable	α	Pearson correlation (<i>r</i>)		
		1	2	3
1. Attitude	.56		0.49*	0.10*
2. Responsibility	.77			0.16*
3. Concern	.85			

* $p < .01$

As shown in Table 5, the correlation coefficient was found to be 0.49 between the attitude and responsibility variables, 0.10 between attitude and concern, and 0.16 between responsibility and concern. Therefore, all the Pearson correlations were significant at the 0.01 significance level. The reliability coefficients were between 0.56 and 0.85, which are consistent with the results of the previous studies.

Figure 1 presents the mediation model using a diagram. In the model, attitude is the mediator variable between the concern and responsibility variables, and *a*, *b*, and *c'* are the regression coefficients. *c'* is the direct effect of concern on responsibility where the indirect effect of concern on responsibility through attitude is $a*b$. The total effect of concern on responsibility, denoted as *c*, is the sum of direct and indirect effects ($c' + a*b$).

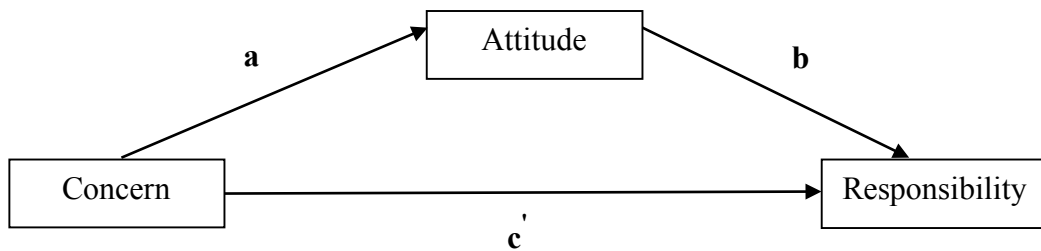
*Figure 1. Mediation model diagram*

The two regression equations of the present model are:

$$(1) \text{ Attitude} = i_1 + a\text{Concern}$$

$$(2) \text{ Responsibility} = i_2 + c'\text{Concern} + b\text{Attitude}, \text{ where } i_1 \text{ and } i_2 \text{ are the regression intercepts.}$$

Table 6.

Path coefficients from the model

		<i>Attitude</i>			<i>Responsibility</i>		
		<i>Regression coefficient</i>	<i>SE</i>	<i>p</i>			
		<i>Regression coefficient</i>	<i>SE</i>	<i>p</i>	<i>Regression coefficient</i>	<i>SE</i>	<i>p</i>
Concern	A	.065	.016	<.001	c'	.133	.024 <.001
Attitude					b	.836	.037 <.001
Constant	i ₁	32.332	.549	<.001	i ₂	42.156	1.458 <.001
		R ² =0.009			R ² =0.255		
		F(1, 1653)=16.219, p<.001			F(2, 1652)=283.534, p<.001		

Table 6 presents the results of the mediation analysis. According to the results, the coefficients a, b, and c' are significant. Coefficient a (a=0.065) indicates that there is a significant correlation between the concern and attitude variables, which means that as the concern scores increase by one unit, attitude scores increase by 0.065 unit. The regression coefficient b (b=0.836) shows that there is a significant correlation between the attitude and responsibility variables; so, when attitude increases by one unit, responsibility scores increase by 0.84 units. The indirect effect of attitude on responsibility (a*b= 0.054), on the other hand, means that as the variable concern increases by one unit, responsibility increases by 0.054 unit. The direct effect of concern on responsibility (denoted as c', was computed as 0.133 as displayed in Table 6) is the estimated difference in environmental responsibility between two PTs with the same level of environmental attitude but different level of environmental concern (one unit). The coefficient is positive, which means that a PT with more concern but an equal level of attitude is estimated to possess 0.133 units higher responsibility.

The indirect effect of concern on responsibility through attitude (a*b) shows the difference related to the effect of concern that will be created on responsibility; when the concern score increases by one unit as a result of the influence of attitude on concern, it influences responsibility. In terms of the direct effect, however, it is necessary to determine whether the indirect effect is different from zero (Hayes, 2013). If this is the case, then it can be suggested that attitude serves as a mediator variable for the effect of concern on responsibility. According to the bootstrap confidence interval generated by the PROCESS for the indirect effect in the mediation model, the lower limit of the bootstrap confidence interval (BootLLCI) for the indirect effect was 0.0269 and the upper limit (BootULCI) was 0.0832. Since this interval does not include zero, it can be concluded that attitude has a significant mediating effect on the relationship between the variables of concern and responsibility. Finally, the total effect of concern on responsibility (c= c' + a*b) is the sum of direct and indirect effects and computed as 0.187, which is statistically significant with p being <0.001 and the confidence level being somewhere between 0.1328 (LLCI) and 0.2418 (ULCI).

In the mediation analysis, when a mediator variable reduces the relationship between the independent and dependent variable to zero, it is called a full mediation. In our case, when attitude was included as the mediator variable into the model, the relationship between concern and responsibility were not reduced to zero; however, it was close to zero, and the PROCESS analysis revealed that the indirect effect was significant. Therefore, we can conclude that there was an indirect effect between the variables of this study and attitude had a significant mediating effect on the relationship between concern and responsibility.

The Moderating Effect of Gender on the Relationship between Environmental Concern and Responsibility

In the moderation analysis, the moderating effect of gender on the relationship between concern and responsibility was investigated. Figure 2 presents the related conceptual model and the equation of the analysis is given below:

$$\text{Responsibility} = i_1 + c_1 \text{Concern} + c_2 \text{Gender} + c_3 \text{Concern} * \text{Gender}$$

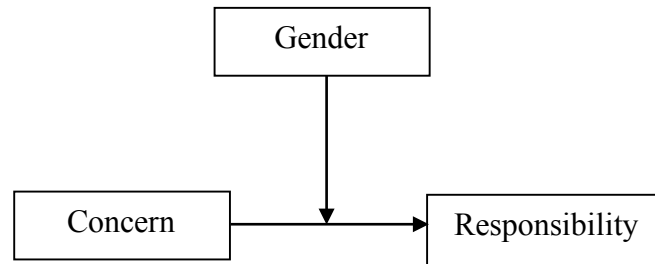

Figure 2. Conceptual model of the moderation analysis

As shown in the statistical models (Figure 3), the paths are; 1-) from the independent variable to the dependent variable, 2-) from the moderator variable to the dependent variable, and 3-) from the interaction variable (concern*gender) to the dependent variable.

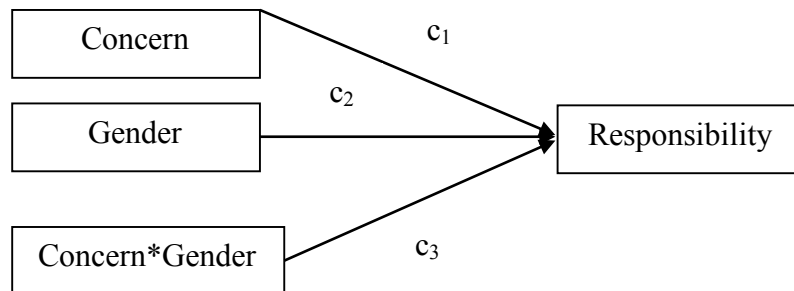

Figure 3. Statistical model of the moderation analysis

In the statistical model, the key result is the estimate of c_3 not being statistically different from zero, which means that the effect of concern is not dependent, at least linearly, on gender. On the contrary, if c_3 was significantly different from zero, it would be an indication that the effect of concern depended on gender. Table 7 presents the results from the PROCESS analysis examining the moderation effect of gender on the relationship between concern and responsibility.

Table 7.

Results of the moderation analysis

		<i>Coeff.</i>	<i>SE</i>	<i>t</i>	<i>p</i>
Intercept	i ₁	75.468	0.191	394.888	<.001
Concern (X)	c ₁	0.187	0.034	5.580	<.001
Gender (M)	c ₂	0.430	0.447	0.962	.336
Concern*Gender (XM)	c ₃	0.041	0.077	0.532	.595

R²=0.028, MSE=59.688
F(3, 1631)=11.741, p<.001

The regression coefficient for XM was found to be 0.041 and was not statistically different from zero, with t(1631) being 0.532 and p being 0.595. Thus, the effect of concern on responsibility does not depend on gender. This means that the relationship between concern and responsibility did not differ in females and males. The non-significant moderation effect of gender on the relationship between concern and responsibility was also supported by the PROCESS output, which displayed the range between the lower limit confidence interval (LLCI = -0.1098) and the upper limit confidence interval (ULCI = 0.1914) for the interaction including zero.

The Moderation Effect of Gender on the Relationship between Attitude and Responsibility

The possible moderation effect of gender on the relationship between attitude and responsibility was investigated using moderation analysis. Figure 4 presents the related conceptual model and the equation of the analysis is given below:

$$\text{Responsibility} = i + c_1\text{Attitude} + c_2\text{Gender} + c_3\text{Attitude} * \text{Gender}$$

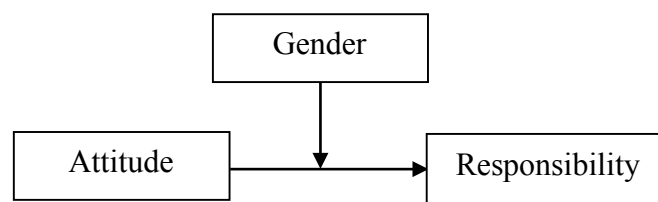

Figure 4. Conceptual model of the moderation analysis

As shown in statistical models (Figure 5), the paths are; 1-) from the independent variable to the dependent variable, 2-) from the moderator variable to the dependent variable, and 3-) from the interaction (attitude*gender) to the dependent variable.

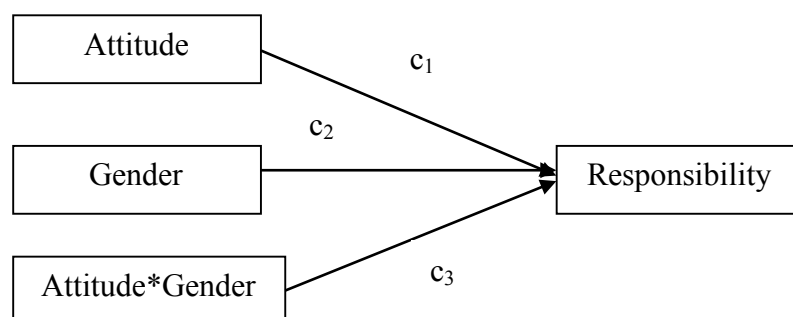

Figure 5. Statistical model of the moderation analysis

In this statistical model, the estimate of c_3 was not statistically different from zero, which means that the effect of attitude was not dependent, at least linearly, on gender. If c_3 was significantly different from zero, we would conclude that the effect of attitude depended on gender. Table 8 gives the results from the PROCESS analysis examining the moderation effect of gender on the relation between attitude and responsibility.

Table 8.

Results of the moderation analysis

		<i>Coeff.</i>	<i>SE</i>	<i>t</i>	<i>p</i>
Intercept	i_1	75.479	0.169	447.012	<.001
Attitude (X)	c_1	0.846	0.061	13.772	<.001
Gender (M)	c_2	-0.101	0.372	-0.272	.786
Attitude*Gender (XM)	c_3	-0.103	0.128	-0.801	.423
		$R^2=0.244$, $MSE=46.425$			
		$F(3, 1631)=64.954$, $p<.001$			

The regression coefficient for XM was -0.103 and was not statistically different from zero with $t(1631)$ being -0.801 and p being 0.423. Therefore, the effect of attitude on responsibility did not depend on gender. In other words, the relationship between attitude and responsibility was not different in females and males. The non-significant moderation effect of gender on the relationship between attitude and responsibility is also observed from the PROCESS output, which gives the range between the lower limit confidence interval (LLCI = -.3550) and the upper limit confidence interval (ULCI = .1492) for the interaction including zero.

Discussion and Conclusions

We began with an ambitious question, “how to remedy environmental education”. We were inspired by the claims asserting that affective components of environmental

literacy are the key to define a person as inevitably environmentally literate. Our purpose was to explore the effect of attitude on the other affective dimensions of environmental literacy; namely environmental concern and responsibility. We used the mediation analysis to explore the effect of environmental attitude on the relationship between the variables of environmental concern and environmental responsibility. In addition, we used the moderation analysis to determine the effect of gender on the relationship between environmental concern and environmental responsibility, and between attitude toward environment and environmental responsibility.

As a result, we found that attitude had a significant mediating effect on the relationship between concern and responsibility. We can, therefore, conclude that attitude is one of the major components that determine operational environmental literacy. Although this is not a new finding, it is important in terms of displaying the mediating effect of attitude. It is not sufficient to consider the direct effects of internal and external factors to explain pro-environmental behaviour; the mediating effects also need to be explored. As shown in the present study and also reported by Kollmuss and Agyeman (2002), the biggest positive influence on pro-environmental behaviour is achieved when internal and external factors act synergistically.

Our findings related to PTs' scores on attitude, concern and responsibility items demonstrate the mediating effect of attitude on concern and responsibility. Although the PTs in this study had high attitudes scores, they seemed to be undecided when asked about the interrelation between human and nature. Yet, their environmental concern was mainly with regard to the problems of national concern. They perceived the global problems as the results of/reasons for the national ones, which indicate that there is a further interrelation/s between affective/internal factors. In other words, PTs in this study were not sure about the relationship between human and nature and this uncertainty resulted in their environmental concern being limited to the problems that they personally experienced. Accordingly, their responsibility towards the environment was similar. When asked whether they agreed to the statement, "Wild animals that provide meat for people are the most important species to protect", 36 % remained undecided. Thus, the way PTs in this study "*read*" the environment can be the result of a cultural/social construct rather than a scientific one, and according to our results, this is mediated by their attitude.

We also tested the moderating effect of gender on the relationships between environmental concern and responsibility, and between attitude and responsibility, and found that these relationships did not differ in females and males. Previous research describing gender as an agent causing difference in values, behaviour, beliefs, attitudes, concern, pro-environmental views (Stern et al., 1993; Xiao & McCright, 2015) and vulnerability to risk (Bord & O'Conner, 1997) has focused on the effect of gender on the individual variables; however, in this study, we focused on the mediating effect of gender on the relationship between other variables (environmental concern and environmental responsibility). To be precise, although gender makes a difference on attitude, for most of the cases, it does not do so when its effect is questioned with the regard to the relationships between the variables; thus supporting the difference shown by the mediation analysis.

In the literature, a few studies used mediation and moderation analyses in education and/or environmental education (e.g. Tarrant, Bright, & Cordell, 1997; Vaske & Kobrin, 2001). Yet, to our knowledge, there is no research investigating the mediating effect of attitude on the relationship between environmental concern and environmental responsibility, and the moderator effect of gender on the variables of environmental literacy. We, therefore, suggest that mediation and moderation analyses are useful to explore the interrelations between environmental literacy variables and further research should be conducted on other variables, particularly to explore the mediating

effect of knowledge on attitude. Furthermore, considering the changing nature of pro-environmental attitudes depending on current events and variations with age, gender, socioeconomic status, culture, urban-rural residency, religion, worldview, values, personality, experience, education and environmental knowledge, we suggest and encourage further attempts to perform a moderation analysis to explore the effects of the above-mentioned variables on attitude.

In conclusion, we are aware that the results and evaluations of this study are not a complete remedy for environmental education. However, we have proposed an alternative approach to asserting that the affective components of environmental literacy are the key to define a person as inevitably environmentally literate.

Furthermore, through our results we assert that, although we do not entirely deny the importance of cognitive component, affective components of environmental literacy shall be emphasized to define and raise persons inevitably environmentally literate. Because, through our results we added to environmental literacy reserach that, the relationship between environmental concern and responsibility may operate through attitude and consideration of this mechanism help us educators in developing effectiveness of education for sustainable development (ESD). As a matter of fact, the recent research and practice in ESD is in line with our claim. For example through their evaluations on the results project titled "Hello, Spring!" Eelma et al. (2015) reported that, values and attitudes come from childhood and home plays an enormous role in the formation of attitudes and so does school and education. According to the results of the project, the authors claim that nature education improves the quality of life by sharing human values; it helps to develop respect, honesty, compassion, care and responsibility. Through the activities of the project which carry all these values, the development of a remarkable number of children's values and attitudes towards life around us is positively influenced. Similarly, Strode (2015) states that in the current life sytles, education provides sphere of activities where the experience of humanity, society and an individual - knowledge, skills, attitudes and value-orientation in terms of the human him/herself, the human environment and nature - is particularly collected, maintained and distributed. Therefore, education is an intellectual need that has to assist people in maintaining and developing attitude towards values, intellectual values. Thus, according to the author the overall process of upbringing and education shall be value-oriented only in case if we can implement the principle of wholeness or holistics. And as Kõiv (2015) reported in their study to touch the students' values, and offer practical tasks and vary the teaching methods in order to create connections between the students' own lives, their communities and other peoples in different parts of the world. As the author stated, encouraging students to share their thoughts and attitudes and building their current values will have an influence their responsibility for the future, as well as the knowledge or facts they have learned about the World.

All in all, in line with the results of this research we draw out that giving the importance the affective components of environmental literacy deserve promises to develop the efficiency of ESD, thus raising more responsible generations, because as Nicol (2015) wrote "Love has got to do everything".

▪ ▪ ▪

References

- Arnon, S., Orion, N., & Carmi, N. (2014). Environmental literacy components and their promotion by institutions of higher education: An Israeli case study. *Environmental Education Research*. Advance online publication. doi:10.1080/13504622.2014.966656

- Bord, R. J., & O'Connor, R. E. (1997). The gender gap in environmental attitudes: The case of perceived vulnerability to risk. *Social Science Quarterly*, 78(4), 830-840.
- Barrow, R. (1980). *The Canadian curriculum: A personal view*. London, Ontario: University of Western Ontario.
- Bradley, J. C., Waliczek, T. M., & Zajicek, J. M. (1999). Relationship between environmental knowledge and environmental attitude of high school students. *The Journal of Environmental Education*, 30(3), 17-21.
- Cheng, I. N. Y., & So, W. W. M. (2015). Teachers' environmental literacy and teaching -stories of three Hong Kong primary school teachers. *International Research in Geographical and Environmental Education*, 24(1), 58-79.
- Cordano, M., Welcomer, S. A., & Scherer, R. F. (2003). An analysis of the predictive validity of the new ecological paradigm scale. *The Journal of Environmental Education*, 34(3), 22-28.
- Dunlap, R. E., & Van Liere (1978). The new environmental Paradigm: A proposed measuring instrument and preliminary results. *Journal of Environmental Education*, 9(4), 10-19.
- Dunlap, R. R., Van Liere, K. D., Mertig, A. G., & Jones, R. E. (2000). Measuring endorsement of new environmental paradigm: A revised NEP scale. *Journal of Social Issues*, 5(3), 425-442.
- Eelma, T., Muuli, V., Rajasaar, V., Ruusmaa, J. and Tuisk, T. (2015, April). *Project „Hello, Spring!“ - Over 20 years of Values Education through Nature and Environmental Education*. Paper presented at Pathways to the Future: Education for Sustainable Development, Tallinn, Estonia, p.42.
- Erdogan, M., & Ok, A. (2011). An Assessment of Turkish Young Pupils' environmental literacy: A nationwide survey. *International Journal of Science Education*, 33(17), 2375-2406.
- Esa, N. (2010). Environmental knowledge, attitude and practices of student teachers. *International Research in Geographical and Environmental Education*, 19(1), 39-50.
- Fraenkel, J. R., & Wallen, N. E. (2006). *How to design and evaluate research in education* (6th ed.). New York: McGraw-Hill.
- Gardner, Howard (1999). *The Disciplined Mind: Beyond Facts and Standardized Tests, The K-12 Education That Every Child Deserves*. New York: Simon and Schuster (and New York: Penguin Putnam).
- Goldman, D., Assaraf, O. B. Z., & Shaharabani, D. (2013). Influence of a non-formal environmental education programme on junior high school students' environmental literacy. *International Journal of Science Education*, 35(3), 515-545.
- Goldman, D., Yavetz, B. & Pe'er, S. (2006). Environmental literacy in teacher training in Israel. *Environmental Behavior of New Students*, 38(1), 3-22.
- Hayes, A. F. (2012). PROCESS: A versatile computational tool for observed variable mediation, moderation, and conditional process modeling [White Paper]. Retrieved from <http://www.afhayes.com/public/process2012.pdf>
- Hayes, A. F. (2013). *Introduction to mediation, moderation, and conditional process analysis: A regression-based approach*. New York: The Guilford Press.
- Hungerford, H., Peyton, R., & Wilke, R. (1980). Goals for curriculum development in environmental education. *The Journal of Environmental Education*, 11(3), 42-47.
- Hsu, S. J (2004). The effects of an environmental education program on responsible environmental behaviour and associated environmental literacy variables in Taiwanese college students. *The Journal of Environmental Education*, 35(2), 37-48.

- Hsu, S., & Roth, R. E., (1998). An assessment of environmental literacy and analysis of predictors of responsible environmental behaviour held by secondary teachers in the Hualien Area of Taiwan. *Environmental Education Research*, 4(3), 229-249.
- Hsu, S., & Roth, R. E., (1999). Predicting Taiwanese secondary teachers' responsible environmental behaviour through environmental literacy variables. *The Journal of Environmental Education*, 30(4), 11-18.
- Hungerford, H. R. & Volk, Y. (1990). Changing learner behaviour through environmental education. *Journal of Environmental Education*, 35(2), 37-48.
- Kaplowitz, M. D., & Levine, R. (2005). How environmental knowledge measures up at a Big Ten university. *Environmental Education Research*, 11, 143-160.
- Kollmuss, A., & Agyeman, J. (2002). Mind the Gap: Why do people act environmentally and what are the barriers to pro-environmental behaviour? *Environmental Education Research*, 8(3), 239-260.
- Kõiv, I. (2015, April). *Why should they care?* Paper presented at Pathways to the Future: Education for Sustainable Development, Tallinn, Estonia, p.64.
- Marcincowski, T. (1991). The relationships between environmental literacy and responsible environmental behaviour in environmental education. In M. Maldague (Ed.), *Methods and techniques for evaluating environmental education*. Paris: UNESCO.
- McBeth, W., & Volk, T. (2009). The national environmental literacy project: A baseline study of middle grade students in the United States. *The Journal of Environmental Education*, 41(1), 55-67.
- McMillan, E., Wright, T., & Beazley, K. (2004). Impact of university-level environmental studies class on students' values. *The Journal of Environmental Education*, 35(3), 19-28.
- Milfont, T. L., & Duckitt, J. (2010). The environmental attitudes inventory: A valid and reliable measure to assess the structure of environmental attitudes. *Journal of Environmental Psychology*, 30, 80-94.
- Nicol, R. (2015, April). *What's love got to do with it? Probably everything*. Paper presented at Pathways to the Future: Education for Sustainable Development, Tallinn Estonia, p.29.
- Pe'er, S., Goldman, D., & Yavetz, B. (2007). Environmental literacy in teacher training: Attitudes, knowledge, and environmental behaviour of beginning students. *The Journal of Environmental Education*, 39(1), 45-59.
- Roth, C. E. (1968). *On the Road to Conservation*, 38-41. Massachusetts: Audubon.
- Roth, C. E. (1992). *Environmental literacy: Its roots, evolution, and directions in the 1990s*. Columbus, OH: ERIC/CSMEE.
- Shephard, K., Harraway, J., Lovelock, B., Skeaff, L. S., Strack, M., Furnari, M., & Jowett, T. (2014). Is the environmental literacy of university students measurable? *Environmental Education Research*, 20(4), 476-495.
- Stables, A., & Bishop, K. (2001). Weak and strong conceptions of environmental literacy: Implications for environmental education. *Environmental Education Research*, 7(1), 89-97.
- Stern, P. C., Dietz, T., Kalof, L. (1993). Value Orientations, gender, and environmental concern. *Environment and Behaviour*, 25, 322-348.
- Strode, I. (2015, April). *Highlighting the value prototyper of modern young people in the context of sustainable education and development*. Paper presented at Pathways to the Future: Education for Sustainable Development, Tallinn, Estonia, p.62.
- Tarrant, M. A., Bright, A. D., & Cordell, H. K. (1997). Attitudes toward wildlife species protection: Assessing moderating and mediating effects in the value-attitude relationship. *Human Dimensions of Wildlife: An International Journal*, 2(2), 1-20. doi: 10.1080/10871209709359091

- Tsevreni, I. (2011). Towards an environmental education without scientific knowledge: an attempt to create an action model based on children's experiences, emotions and perceptions about their environment. *Environmental Education Research, 17*(1), 53-67.
- UNESCO-UNEP (1989). Environmental Literacy for all. *Connect, 15*(2), 1-2.
- UNESCO-UNEP (1977). *Intergovernmental Conference on Environmental Education in Tbilisi*, (USSR) Columbus.
- United Nations Millennium Declaration (2000). *Resolution adopted by the General Assembly. 55/2*.
- Vaske, J. J., & Kobrin, K. C. (2001). Place attachment and environmentally responsible behavior. *The Journal of Environmental Education, 32*(4), 16-21. doi: 10.1080/00958960109598658
- Xiao, C., & McCright, A. M. (2015). Gender differences in environmental concern revisiting the institutional trust hypothesis in the USA. *Environment and Behavior, 47*(1), 17-37.
- Yavetz, B., Goldman, D., & Pe'er, S. (2009). Environmental literacy of pre-service science teachers in Israel: A comparison between students at the onset and end of their studies. *Environmental Education Research, 15*(4), 393-415.

Duyuşsal Faktörlerin Çevre Okuryazarlığına Etkileri: Aracı ve Etkileşim Değişkenleri İle Model Testi

Nilay ÖZTÜRK*

Middle East Technical University

Gaye TEKSÖZ

Middle East Technical University

Özet

Bu çalışmanın amaçları 1- öğretmen adaylarının çevreye yönelik tutumlarının çevreye yönelik kaygı ve sorumluluk değişkenleri arasındaki ilişki üzerinde aracı bir etkisinin olup olmadığını ve 2- cinsiyet değişkeninin çevreye yönelik kaygı ve sorumluluk ile çevreye yönelik tutum ve sorumluluk ilişkileri üzerinde etkileşiminin olup olmadığını araştırmaktır. Çalışmanın veri toplama aracı olan Çevre Okuryazarlığı Anketi toplamda 1626 öğretmen adayına uygulanmıştır. Çalışmanın sonuçları göstermiştir ki, öğretmen adaylarının çevreye yönelik tutumları, çevreye yönelik kaygı ve sorumluluk değişkenleri arasındaki ilişki üzerinde anlamlı bir aracı etkiye sahiptir. Bunun yanı sıra, etkileşim analizlerinin sonuçlarına göre, cinsiyet değişkeninin çevreye yönelik kaygı ve sorumluluk değişkenleri ile çevreye yönelik tutum ve sorumluluk değişkenleri arasındaki ilişkiler üzerinde anlamlı bir etkileşimi yoktur.

Anahtar Kelimeler: Çevre okuryazarlığı, tutum, çevreye yönelik sorumluluk, cinsiyet, aracı değişken analizi, etkileşim değişkeni analizi.

The Impact of Affective Constraints on Shaping Environmental Literacy: Model Testing Using Mediator and Moderator Variables

Nilay ÖZTÜRK*

Middle East Technical University

Gaye TEKSÖZ

Middle East Technical University

To cite this article: Öztürk, N. & Teksöz, G. (2016). The impact of affective constraints on shaping environmental literacy: Model testing using mediator and moderator variables. *International Electronic Journal of Environmental Education*, 6(2), 54-75.

Abstract

The aims of this study were; first to investigate the mediating effects of pre-service teachers' (PTs) attitude toward environment on the relationship between their environmental concern and environmental responsibility, and second, to explore the moderating effect of gender on the relationships between; PTs' environmental concern and responsibility; and environmental attitude and responsibility. A total of 1626 PTs completed the Environmental Literacy Survey. The findings revealed that PTs' attitude had a significant mediating effect on the relationships between environmental concern and responsibility. Furthermore, the results of the moderation analysis showed that the relationships did not differ in female and male participants.

Key words: Environmental literacy, attitude, responsibility, gender, mediation, moderation.

Introduction

Our attempt with this research is to explore the mediating effect of attitude toward environment on the relationship between environmental concern and environmental responsibility. Besides, we attempted to reveal the moderating effect of gender on the relationship between environmental concern and environmental responsibility and the moderating effect of gender on the relationships between attitude toward environment and environmental responsibility. What brought us to investigate the relation among these environmental literacy dimensions through mediation and moderation analysis however is the inconsistency related to the impact of attitude on the other components of environmental literacy (EL). Therefore in the following section we have put our reasonings forward in relation with the history of EL research, than we presented the results obtained by the use of one of the novel approach (mediation and moderation analysis). Therefore the context of this research is to propose a new insight to EL literature for attempting to explore the relationships between affective components of EL (environmental concern, responsibility, attitude) as well as the effect of gender on these relationships by model testing using mediator and moderator analysis thus to invigorate one of the inconsistent areas of EL research.

The concept of environmental literacy was first defined by Roth in an article for Massachusetts Audebon (1968). He was replying "to the then frequent media references to environmental illiterates who were responsible for polluting the

environment” (Roth, 1992 p. 7). Roth then asked the question, “how shall we know the environmentally literate citizen?” (p. 7), which became the starting point for discussion and the development of the concept. Although concern about the environment has substantially developed since then and now refers to much more than pollution, developing environmental literacy remains the primary goal of environmental education.

In the early days, the Tbilisi declaration (UNESCO-UNEP, 1977) was important in marking the beginning of the idea of environmental education and opened the way for definitions of environmental literacy. In 1980, Hungerford, Peyton, and Wilke (1980) defined the environmentally literate as having positive attitudes, strong sense of responsibility as well as knowledge on issues and action strategies. In their announcement of the 1990 as the International Environmental Literacy Year, the United Nations offered a broad definition of environmental literacy (UNESCO-UNEP, 1989). During the 1990s, environmental literacy was refined by Marcinkowski (1991), who expanded on the definition in the Tbilisi declaration. Subsequently, Roth (1992) defined environmental literacy as having the four strands of; knowledge, skills, affect (sensitivity, attitude and values) and behaviour (personal investment, responsibility, active involvement). Moreover, he emphasized the unique feature of environmental literacy in that it goes beyond the cognitive skills, involving thinking, acting and valuing. Furthermore, declaring that there is variation in people’s development of environmental literacy Roth (1992) determined that there were three levels of environmental literacy; namely, nominal, functional and operational, in each of which there are the stages of awareness, concern, understanding and action. Roth (1992) also emphasized that capability at a particular developmental stage should not be confused with the achievement of the operational literacy itself. As he wrote, “a person who is environmentally aware is not necessarily environmentally literate; nor is a person who possesses broad environmental understanding; nor is one who demonstrates great environmental concern; nor necessarily is one who takes action on environmental issues” (p. 27).

Stables and Bishop (2001), on the other hand, argued that references to environmental literacy in the environmental education literature do not refer to fundamental debates about literacy. According to the authors, the justification for using the term in the way that it appears in those references remains limited due to existing notions of environmental literacy having a lack of grounding in the literacy debate outside environmental education. Therefore, Stables and Bishop consider the environment as the text and they make distinctions between strong (taking a broad view of literacy and acknowledging its full ramifications with environmental education) and weak (inconsistent with the field of environmental education) conceptions of environmental literacy. Accepting the environment as the text, however, brings authors to the point that, “we do not merely understand our environment scientifically, or in terms of one scientific approach, but ‘read’ it historically, aesthetically, and so on” (p. 93). Yet, according to the authors, “there are many ‘correct’ or different ways of understanding the environment” (p. 93). Thus, beginning from the end of the 20th century, the debate related to environmental literacy has continued concerning the relationships between the components of attitudes, knowledge and responsible environmental behaviour (Arnon, Orion, & Carmi, 2014; Cheng & So, 2015; Erdogan & Ok, 2011; Esa, 2010; Goldman, Assaraf, & Shaharabani, 2013; Goldman, Yavetz, & Pe’er, 2006; Hsu, 2004; Hsu & Roth, 1998; Hsu & Roth, 1999; McBeth, Trudi, & Volk, 2009; Pe’er, Goldman, & Yavetz, 2007; Shephard et al., 2014; Author, 2013; Yavetz, Goldman, & Pe’er, 2009). In other words, the debate that was about the definition of the environmental literacy in the 1990s now focuses on the relationships among the components that explain the achievement of overall operational environmental literacy.

In the related literature, the target has moved to the changes occurring in the components themselves and the relationship between the components over time and with and without exposure to environmental education (Pe'er, Goldman, & Yavetz, 2007). According to a considerable amount of research, increasing an individual's environmental knowledge results in more positive attitudes toward the environment (Bradley, Waliczek, & Zajicek, 1999; McMillan, Wright, & Beazley, 2004). However, the relationship between the cognitive components, affective components and behaviour maintain their complexity. Therefore, we still adhere to the claim made by Hungerford and Volk in 1990 that knowledge, as a critical component of environmental literacy, is not on its own, a sufficient precursor for environmentally responsible behaviour. The affective components are necessary for the transfer of knowledge into responsible environmental behaviour and are important for the development environmental literacy.

The background for the current debate related to the relationships among the components of environmental literacy relies upon Roth's (1992) claim given above. He stated that in terms of the stages of environmental literacy capability at a particular developmental stage should not be confused with achievement of operational literacy itself. This raises the question of what the most predominant component that determines operational environmental literacy is and whether there is a key component of environmental literacy that would allow us define a person as inevitably environmentally literate.

In a study that explores the barriers to pro-environmental behaviour, Kollmuss and Agyeman (2002) proposed a model for pro-environmental behaviour. Their model displayed how the different factors influence each other and pro-environmental behaviour and that most of the factors are self-explanatory. As well as reporting that the greatest positive influence on pro-environmental behaviour is achieved when internal and external factors act synergistically, the authors reported that environmental knowledge, values, and attitudes, together with emotional involvement make up a complex which is called 'pro-environmental consciousness'. Likewise, Tsevreni (2011) presented an alternative approach to environmental education that focuses on children's ideas and action rather than scientific knowledge.

The tendency of environmental educators to focus on emotion rather than scientific knowledge has echoes of Gardner's multiple intelligence theory (1999) and his attitude towards understanding:

I want my children to understand the world, but not just because the world is fascinating and the human mind is curious. I want them to understand it so that they will be positioned to make it a better place. Knowledge is not the same as morality, but we need to understand if we are to avoid past mistakes and move in productive directions. An important part of that understanding is, knowing who we are and what we can do... Ultimately, we must synthesize our understandings for ourselves. The performance of understanding that try matters are the ones we carry out as human beings in an imperfect world which we can affect for good or for ill (p. 180-181).

The reason behind such a discussion is beyond the scientific curiosity; it is related to the search for more effective environmental education and the development of environmentally literate future generations. Five decades have passed since Roth posed the question ("how shall we know the environmentally literate citizen?"), but it appears that there is not sufficient progress in increasing our knowledge of the environment. Furthermore, there needs to be an assessment of how environmental education has developed in line with the important global problems which were described by the UN Millennium goals in 2000 which include; poverty, hunger, primary education, gender equality, child mortality, and environmental sustainability. Therefore, environmental education as a source of knowledge needs regenerating by strengthening the concept of environmental literacy.

The way to remedy environmental education may come from the following three assertions as given above: 1. Different people are drawn to different semiotic systems (Gardner, 1999). 2. Capability at a particular developmental stage should not be confused with the achievement of the operational literacy itself (Roth, 1992) 3. We do not merely understand our environment scientifically or in terms of one scientific approach, but “read” it historically, aesthetically, and so on. Thus, there are many “correct” or different ways of understanding the environment (Stables & Bishop, 2001). We have inferred that what these three statements appear to have in common is the affective components of environmental literacy, and this may be the key that can allow us to define a person as inevitably environmentally literate.

Moreover, the above-mentioned claims lead us to focus on environmental attitudes that have been defined as a psychological tendency expressed by evaluating the natural environment with some degree of favour or disfavour (Milfont & Duckitt, 2010). Attitudes apply to general feelings toward ecology and the environment, feelings and concern for specific environmental issues and feelings towards acting to remedy environmental problems. Pro-environmental attitudes rise and fall with current events and vary with age, gender, socioeconomic status, nation, urban-rural residence, religion, politics, values, personality, experience, education, and environmental knowledge. Therefore, environmental attitudes are important because they often, but not always, determine behaviour that either increases or decreases environmental quality.

One of the scales to measure environmental attitudes is the New Environmental Paradigm (NEP) developed by Dunlap and Van Liere (1978) and that was later revised as the New Ecological Paradigm Scale (Cordano, Welcomer, & Scherer, 2003; Dunlap, Van Liere, Mertig, & Jones, 2000). Providing a tool for evaluating an individual’s environmental orientation, NEP represents an ecocentric worldview and allows researchers to assess an individual’s environmental orientation on a continuum from ecocentrism to anthropocentrism.

From the literature search, we have hypothesized that the key component of environmental literacy which allows us to define a person as inevitably environmentally literate may be related to affective components, and for our study, we defined the affective components as; environmental attitudes, concern and responsibility.

It is evident from the environmental education literature that there is a relationship between environmental concern and responsibility; however, we need to explore the mechanism(s) through which an effect operates and how its boundary conditions or contingencies are established. Therefore, posing questions of “how” and “when” may result in a deeper understanding of these components of environmental literacy, thus leading us define a person’s environmentally literacy (Hayes, 2012). Accordingly, our purpose was to explore the effect of attitude on the other affective dimensions of environmental literacy namely; environmental concern and responsibility.

To explore the effects of attitude toward environment on the relationship between environmental concern and environmental responsibility we used the mediation analysis as proposed by Hayes (2013). In addition, we used moderation analysis to determine the effect of gender on the relationship between environmental concern and environmental responsibility, and the effect of gender on the relationship between the attitude towards environment and environmental responsibility. In environmental education literature, gender has generally been evaluated as being implicated in the relation between the value orientations and behaviour. For example; Stern, Dietz, and Kalof (1993) reported that women have stronger beliefs than men about consequences for self, others, and the biosphere.

Similarly, the research undertaken by Bord and O'Conner (1997) showed that differences in perceived vulnerability to risk explain the gender gap found in environmental surveys and other areas of potential risk. As a result, they reported that, in response to every question in the survey that involves reactions to a specific risk, women were more concerned than men; however, in terms of health-risk perceptions of environmental concerns, the gender gap disappeared.

Moreover, research on environmental concern has consistently found that women have modestly stronger pro-environmental values, beliefs, and attitudes than men. Xiao and McCright (2015) used a structural equation modelling technique on General Social Survey data in the US from 2000 and 2010, and found that women report greater pro-environmental views and concern about environmental problems than men.

We chose pre-service teachers (PTs) as the sample because as key people in environmental education, PTs are the preliminary target population in attempts to explore the means of developing the knowledge and practice through more effective environmental education.

The main purposes of the present study are; first to investigate the mediating effects of PTs' attitude toward environment on the relationship between their environmental concern and environmental responsibility. Second, we attempted to reveal the moderating effect of gender on the relationships between PTs' environmental concern and environmental responsibility; and the moderating effect of gender on the relationships between attitude toward environment and environmental responsibility. To this end, our research questions (RQ) were:

RQ.1. What is the mediating effect of the PTs' attitude toward environment on the relationship between their environmental concern and environmental responsibility?

RQ.2. What is the moderating effect of gender on the relationship between the PTs' environmental concern and environmental responsibility?

RQ.3. What is the moderating effect of gender on the relationship between the PTs' attitude toward environment and environmental responsibility?

Methodology

Research Design

The design of the study was based on survey and correlational research. In survey research, certain aspects or characteristics of a group of people are investigated asking them a list of questions (Frankel & Wallen, 2006). Since one of the main purposes of the present study was to reveal the environmental literacy of PTs enrolled in the faculty of education, we chose to use the survey research design. The other research design used in the present study was the correlational research design. In this design, a combination of moderation and mediation analysis was utilized (Hayes, 2013).

Moderation occurs when the relationship between two variables depends on a third variable, called the moderator variable. This third variable is characterized as an interaction. In the correlational analysis framework, a moderator is the third variable that affects the zero-order correlation between an independent and a dependent variable. The moderation analysis aims to answer the questions related to 'when'. In the present study, the moderation analysis was used to determine the effect of gender on the relationships between PTs' environmental concern and environmental

responsibility, and between PTs' attitude toward environment and environmental responsibility.

A mediation model also uses a third explanatory variable, called the mediator variable, to identify and explicate the mechanisms or processes underlying a relationship between an independent and a dependent variable. Mediating relationships occur when the third variable plays an important role in governing a relationship between the two other variables. The mediation analysis focuses on answering the questions related to 'how'. In the present study, the mediation analysis was used to explore the effect of PTs' attitude toward environment on the relationship between their environmental concern and environmental responsibility.

Sample

The participants of this study were 1626 PTs enrolled in the school of education of a university located in Anatolia Region (Kırşehir province) in Turkey. Almost 70 % of the PTs were from the departments of Computer Education and Instructional Technologies, Elementary Education, Turkish Language Education and Social Sciences Education. However the rest were from the Departments of Science Education (16.1%), Mathematics Education (6.6%) and Early Childhood Education (8.5). Thirty percent of the participants were male and 70% were female with the average age of 20.3 years.

Instrument

The instrument used in the study was the Environmental Literacy Survey (Kaplowitz & Levine, 2005). The original survey consists of four main categories with distinct sets of questions concerning knowledge, environmental attitude, responsibility, and concern. However, in the present study, the last three components were utilized. Using these components, the respondents' environmental attitudes (10 items), responsibility (19 items), and concern (9 items) were investigated using a 5-point Likert-type scale. To measure PTs' attitudes and values related to the environment, the environmental attitude items were adapted to the present study from the New Ecological Paradigm Scale (NEP) (Dunlap, Liere, Mertig, & Jones, 2000). The environmental responsibility items measured PTs' perceptions about their responsibility to take part in pro-environmental actions. Finally, the environmental concern items revealed PTs' sensitivity and level of concern related to certain environmental problems and issues. In addition to these items, ten demographic questions were asked to determine the respondents' self-evaluation of their environmental background and obtain personal information; such as age, grade level, department, gender, and parents' level of education.

The instrument was originally developed in English, and previously translated and adapted to Turkish by Author (2009). In their study, the Turkish version of the questionnaire was peer-reviewed by three experts in the field of science education and one expert in the field of environmental science and some revisions were made. The Turkish version of the questionnaire was pilot-tested and its validity has been confirmed by Author (2009). The authors used the Cronbach alpha and found the internal consistency of the environmental attitude, responsibility, and concern dimensions to be 0.64, 0.80, and 0.88, respectively. In the present study, the internal consistency was also assessed using the Cronbach's alpha and found to be 0.56, 0.77, and 0.85 for the attitude, responsibility and concern item sets, respectively. In order to ensure the construct validity, the researchers also carried out a confirmatory factor analysis using AMOS 21. The results indicated a good fit, proved with high fit indices

(RMR= 0.052; GFI= 0.89; RMSEA= 0.051). Since they did not load to the factors significantly, one item related to attitude; namely “The Earth has plenty of natural resources if we just learn how to develop them” and one responsibility item, “Landowners should be allowed to drain wetlands for agricultural or industrial uses”, were omitted.

Data Collection and Analysis

Data collection was carried out during the fall of 2013. One of the authors of the study collected the data from PTs in all classrooms. The consistency of data collection was ensured by following the same procedure in all classrooms. The participation was voluntary and ethical commission permissions were taken prior to the data collection process.

The survey data was quantitatively analysed. Following the descriptive analyses, the mediation analysis was used to reveal the mediating effect of PTs’ attitude toward environment on the relationship between their environmental concern and environmental responsibility. Then, the moderation analysis was conducted to examine the moderating effect of gender on the relationships; between PTs’ environmental concern and environmental responsibility; and between PTs’ attitude toward environment and environmental responsibility. A statistical tool called PROCESS (Hayes, 2012) was used to conduct both the mediation and moderation analyses. Most statistical software does not allow modern moderation and mediation analyses to be conducted in a straightforward way. PROCESS, however, is a versatile modelling tool for SPSS that combines many of the functions of popular procedures and tools (such as SOBEL and INDIRECT) in one simple-to-use procedure.

Findings

We present the results in four sections, in accordance with our research questions: 1. PTs’ self-evaluations about environmental problems; 2. General characteristics of PTs’ environmental literacy; 3. Mediating effects of attitude toward environment on the relationship between environmental concern and environmental responsibility; 4. Moderating effect of gender on the relationships between environmental concern and environmental responsibility, and between attitude and responsibility.

Pre-service Teachers’ Self-evaluations on Their Perceptions Related to Environmental Problems

Participants were asked four questions to evaluate their environmental background about their perceptions regarding environmental problems/issues. As presented in Table 1, 55.2% of Turkish PTs stated that they have a fair amount of environmental concern and 49.4% reported their degree of knowledge about environmental issues and problems to be “only a little”. In addition, 65% of the participants reported environment as the second or most important problem faced globally. In this study, nearly half of the Turkish PTs (48.5%) stated that their childhood and the environmental behaviours of their parents had an influence on their perceptions about environmental problems.

Table 1.

Participants' self evaluation on their environmental background

<i>Item</i>	<i>Agreement (%)</i>
<i>Perceptions on concern about environmental problems</i>	
A lot	5.7
A fair amount	55.2
A little	34.5
Only a little	3.7
Not at all	1.0
<i>Perceptions about the importance of the environmental problems</i>	
Environment as one of the 2 or 3 most important problems	65.0
Environment as an important problem with several more important ones	31.7
Environment as an unimportant problem	1.1
Environment as not a problem	2.2
<i>Perceptions about the degree of knowledge about environmental issues and problems</i>	
A lot	2.1
A fair amount	47.3
Only a little	49.4
Practically nothing	0.6
Don't know	0.6
<i>Do you think your childhood and parents' environmental behaviors have an influence on your perceptions about environmental problems now?</i>	
Yes	48.5
Maybe	33.1
No	11.6
No idea	6.8

Pre-service Teachers' Environmental Literacy in terms of Attitude, Concern and Responsibility

Environmental attitudes. The mean score of Turkish PTs concerning the environmental attitude items was 3.83 out of 5 (SD=1.06). The highest mean score was found to be 4.59 for the item, "Plants and animals have as much right as humans to exist". The lowest mean, on the other hand, was 3.18 that was obtained from the responses to the item, "The balance of nature is strong enough to cope with the impacts of modern industrial nations". Furthermore, this item received the highest frequency (30.9%) among the "undecided" responses, followed by the item, "We are approaching the limit of the number of people the earth can support" (26 %). Therefore, although the M value for the attitude dimension of the Environmental Literacy Survey was reasonably high, the above-mentioned results related to the "undecided" responses indicate that PTs have quite uncertain positions related to the relationship between human beings and environment (Table 2).

Table 2.

Percentage of respondent agreement with environmental attitude items

<i>Item</i>	<i>Frequency (%)</i>			<i>M</i>	<i>S.D.</i>
	<i>Agree</i>	<i>Undecided</i>	<i>Disagree</i>		
We are approaching the limit of the number of people the earth can support.	59.5	26.0	14.5	3.63	1.03
When humans interfere with nature it often produces disastrous consequences.	64.6	19.4	16.0	3.72	1.07
Plants and animals have as much right as humans to exist.	92.6	2.4	5.1	4.59	0.89
The balance of nature is strong enough to cope with the impacts of modern industrial nations.	40.7	30.9	28.4	3.18	1.16
Despite our special abilities humans are still subjects to the laws of nature.	58.2	22.5	19.2	3.53	1.14
The so-called "ecological crisis" facing humankind has been greatly exaggerated.	62.3	23.7	14.0	3.69	1.06
Humans were meant to rule over the rest of nature.	69.2	11.7	19.0	3.81	1.23
Humans will eventually learn enough about how nature works to be able to control it.	80.5	11.1	8.4	4.08	0.99
If things continue on their present course, we will soon experience a major ecological catastrophe.	84.9	8.7	6.5	4.27	0.97
Average	68.0	17.3	14.5	3.83	1.06

Environmental responsibility. For the environmental responsibility items, Turkish PTs scored, on average, 3.97 out of 5. Nearly all the participants agreed to the item, "It is important that everyone be aware of environmental problems" with a mean score of 4.60 and the agreement percentage of 94.8 (Table 3). The next item was "All plants and animals play an important role in the environment", which is similar to the attitude item, "Plants and animals have as much right as humans to exist" that also received the highest mean value. Similarly, the items that consider only human (or non-human) received the highest frequencies of all; for example, "Government should pass laws to make recycling mandatory" (M=4.46); and "Collective action (i.e. movements) is central to solving environmental problems" (M=4.38). However, items that include both human and non-human interrelationships received the lowest frequencies, as in the following items; "Wild animals that provide meat for people are the most important species to protect" (M=3.24) and "Landowners should be allowed to drain wetlands for agricultural or industrial uses" (M=2.68).

Table 3.

Percentage of respondent agreement with environmental attitude items

<i>Item</i>	<i>Frequency (%)</i>			<i>M</i>	<i>S.D.</i>
	<i>Agree</i>	<i>Undecided</i>	<i>Disagree</i>		
We are approaching the limit of the number of people the earth can support.	59.5	26.0	14.5	3.63	1.03
When humans interfere with nature it often produces disastrous consequences.	64.6	19.4	16.0	3.72	1.07
Plants and animals have as much right as humans to exist.	92.6	2.4	5.1	4.59	0.89
The balance of nature is strong enough to cope with the impacts of modern industrial nations.	40.7	30.9	28.4	3.18	1.16
Despite our special abilities humans are still subjects to the laws of nature.	58.2	22.5	19.2	3.53	1.14
The so-called "ecological crisis" facing humankind has been greatly exaggerated.	62.3	23.7	14.0	3.69	1.06
Humans were meant to rule over the rest of nature.	69.2	11.7	19.0	3.81	1.23
Humans will eventually learn enough about how nature works to be able to control it.	80.5	11.1	8.4	4.08	0.99
If things continue on their present course, we will soon experience a major ecological catastrophe.	84.9	8.7	6.5	4.27	0.97
Average	68.0	17.3	14.5	3.83	1.06

Environmental concern. Among the given environmental problems, Turkish PTs were found to have the highest concern for 'water shortage' and 'poor drinking water quality' with the mean scores of 4.26 and 4.25, respectively (Table 4).

Table 4.

Percentage of participants' responses on environmental concern items

<i>Item</i>	<i>Not concerned</i>	<i>A little concerned</i>	<i>Undecided</i>	<i>Somewhat concerned</i>	<i>Very concerned</i>	<i>M</i>	<i>S.D.</i>
Air pollution	3.1	13.7	7.1	58.4	17.8	3.74	1.00
Water pollution	2.0	10.3	7.6	53.4	26.8	3.93	0.96
Automobile emissions	10.7	17.8	17.6	39.5	14.4	3.29	1.22
Industrial wastes	12.2	19.7	17.5	36.3	14.3	3.21	1.25
Hazardous wastes	9.4	16.1	13.4	37.9	23.2	3.49	1.26
Poor drinking-water quality	2.4	6.5	6.3	33.1	51.7	4.25	0.99
Water shortage	2.0	6.3	6.2	34.6	50.9	4.26	0.96
Ozone layer depletion	7.9	16.1	13.2	40.7	22.1	3.53	1.22
Climate change	5.1	13.4	13.8	42.2	25.5	3.70	1.14
Average	6.08	13.3	11.4	41.7	27.4	3.71	1.11

In terms of the results on the descriptive statistics, PTs in this study had positive environmental attitudes and responsibilities when human and environment were separately considered; however, they were undecided when there was a case of interrelation between human and nature.

PTs environmental concern was only regarding the problems of national concern. Water shortage and drinking water quality have currently been on the agenda of Turkey due to the less rainfall compared to past years which is considered to be one of the impacts of climate change. However, the results showed that PTs in this study did not perceive global problems as the results of or reasons for the national problems.

The results of the descriptive analysis, therefore, possess the characteristic of PTs environmental literacy that there may be an additional interrelation/s between environmental attitudes, responsibility and concern, which can further explain the above-mentioned attitudes toward environment.

The Mediating Effect of Attitude toward Environment on the Relationship between Environmental Concern and Environmental Responsibility

As mentioned before, one of the purposes of the present study was to investigate the mediating effects of attitude toward environment on the relationship between environmental concern and environmental responsibility. Before proceeding with the mediation analysis, the Pearson correlation coefficients among the variables were calculated and given in the Table 5 below.

Table 5.

Pearson correlations and reliability of the variables

Variable	α	Pearson correlation (<i>r</i>)		
		1	2	3
1. Attitude	.56		0.49*	0.10*
2. Responsibility	.77			0.16*
3. Concern	.85			

* $p < .01$

As shown in Table 5, the correlation coefficient was found to be 0.49 between the attitude and responsibility variables, 0.10 between attitude and concern, and 0.16 between responsibility and concern. Therefore, all the Pearson correlations were significant at the 0.01 significance level. The reliability coefficients were between 0.56 and 0.85, which are consistent with the results of the previous studies.

Figure 1 presents the mediation model using a diagram. In the model, attitude is the mediator variable between the concern and responsibility variables, and *a*, *b*, and *c'* are the regression coefficients. *c'* is the direct effect of concern on responsibility where the indirect effect of concern on responsibility through attitude is $a*b$. The total effect of concern on responsibility, denoted as *c*, is the sum of direct and indirect effects ($c' + a*b$).

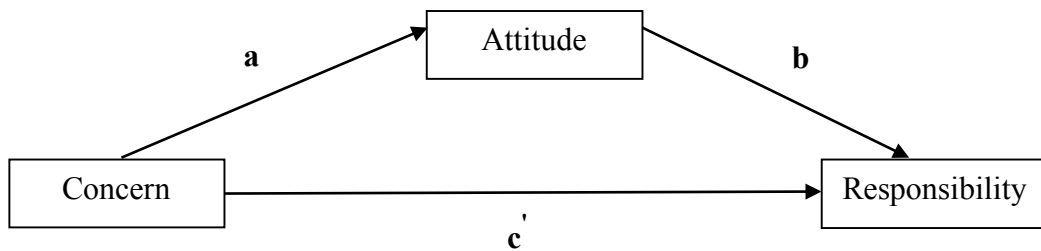
*Figure 1. Mediation model diagram*

The two regression equations of the present model are:

$$(1) \text{ Attitude} = i_1 + a\text{Concern}$$

$$(2) \text{ Responsibility} = i_2 + c'\text{Concern} + b\text{Attitude}, \text{ where } i_1 \text{ and } i_2 \text{ are the regression intercepts.}$$

Table 6.

Path coefficients from the model

		<i>Attitude</i>			<i>Responsibility</i>		
		<i>Regression coefficient</i>	<i>SE</i>	<i>p</i>			
		<i>Regression coefficient</i>	<i>SE</i>	<i>p</i>	<i>Regression coefficient</i>	<i>SE</i>	<i>p</i>
Concern	A	.065	.016	<.001	c'	.133	.024 <.001
Attitude					b	.836	.037 <.001
Constant	i ₁	32.332	.549	<.001	i ₂	42.156	1.458 <.001
		R ² =0.009					R ² =0.255
		F(1, 1653)=16.219, p<.001			F(2, 1652)=283.534, p<.001		

Table 6 presents the results of the mediation analysis. According to the results, the coefficients a, b, and c' are significant. Coefficient a (a=0.065) indicates that there is a significant correlation between the concern and attitude variables, which means that as the concern scores increase by one unit, attitude scores increase by 0.065 unit. The regression coefficient b (b=0.836) shows that there is a significant correlation between the attitude and responsibility variables; so, when attitude increases by one unit, responsibility scores increase by 0.84 units. The indirect effect of attitude on responsibility (a*b= 0.054), on the other hand, means that as the variable concern increases by one unit, responsibility increases by 0.054 unit. The direct effect of concern on responsibility (denoted as c', was computed as 0.133 as displayed in Table 6) is the estimated difference in environmental responsibility between two PTs with the same level of environmental attitude but different level of environmental concern (one unit). The coefficient is positive, which means that a PT with more concern but an equal level of attitude is estimated to possess 0.133 units higher responsibility.

The indirect effect of concern on responsibility through attitude (a*b) shows the difference related to the effect of concern that will be created on responsibility; when the concern score increases by one unit as a result of the influence of attitude on concern, it influences responsibility. In terms of the direct effect, however, it is necessary to determine whether the indirect effect is different from zero (Hayes, 2013). If this is the case, then it can be suggested that attitude serves as a mediator variable for the effect of concern on responsibility. According to the bootstrap confidence interval generated by the PROCESS for the indirect effect in the mediation model, the lower limit of the bootstrap confidence interval (BootLLCI) for the indirect effect was 0.0269 and the upper limit (BootULCI) was 0.0832. Since this interval does not include zero, it can be concluded that attitude has a significant mediating effect on the relationship between the variables of concern and responsibility. Finally, the total effect of concern on responsibility (c= c' + a*b) is the sum of direct and indirect effects and computed as 0.187, which is statistically significant with p being <0.001 and the confidence level being somewhere between 0.1328 (LLCI) and 0.2418 (ULCI).

In the mediation analysis, when a mediator variable reduces the relationship between the independent and dependent variable to zero, it is called a full mediation. In our case, when attitude was included as the mediator variable into the model, the relationship between concern and responsibility were not reduced to zero; however, it was close to zero, and the PROCESS analysis revealed that the indirect effect was significant. Therefore, we can conclude that there was an indirect effect between the variables of this study and attitude had a significant mediating effect on the relationship between concern and responsibility.

The Moderating Effect of Gender on the Relationship between Environmental Concern and Responsibility

In the moderation analysis, the moderating effect of gender on the relationship between concern and responsibility was investigated. Figure 2 presents the related conceptual model and the equation of the analysis is given below:

$$\text{Responsibility} = i_1 + c_1 \text{Concern} + c_2 \text{Gender} + c_3 \text{Concern} * \text{Gender}$$

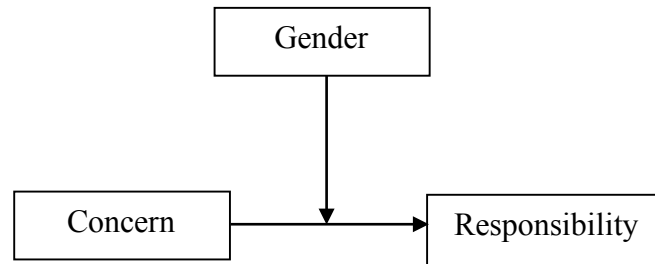

Figure 2. Conceptual model of the moderation analysis

As shown in the statistical models (Figure 3), the paths are; 1-) from the independent variable to the dependent variable, 2-) from the moderator variable to the dependent variable, and 3-) from the interaction variable (concern*gender) to the dependent variable.

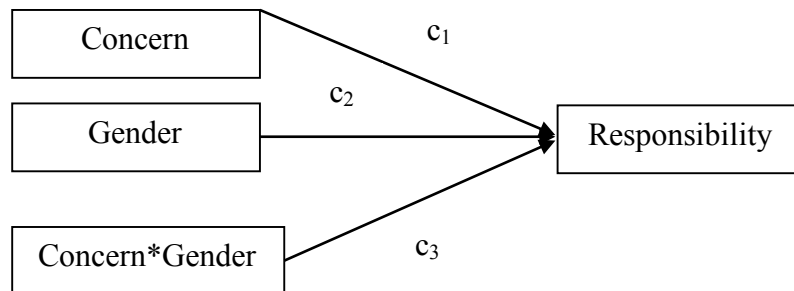

Figure 3. Statistical model of the moderation analysis

In the statistical model, the key result is the estimate of c_3 not being statistically different from zero, which means that the effect of concern is not dependent, at least linearly, on gender. On the contrary, if c_3 was significantly different from zero, it would be an indication that the effect of concern depended on gender. Table 7 presents the results from the PROCESS analysis examining the moderation effect of gender on the relationship between concern and responsibility.

Table 7.

Results of the moderation analysis

		<i>Coeff.</i>	<i>SE</i>	<i>t</i>	<i>p</i>
Intercept	i ₁	75.468	0.191	394.888	<.001
Concern (X)	c ₁	0.187	0.034	5.580	<.001
Gender (M)	c ₂	0.430	0.447	0.962	.336
Concern*Gender (XM)	c ₃	0.041	0.077	0.532	.595

R²=0.028, MSE=59.688
F(3, 1631)=11.741, p<.001

The regression coefficient for XM was found to be 0.041 and was not statistically different from zero, with t(1631) being 0.532 and p being 0.595. Thus, the effect of concern on responsibility does not depend on gender. This means that the relationship between concern and responsibility did not differ in females and males. The non-significant moderation effect of gender on the relationship between concern and responsibility was also supported by the PROCESS output, which displayed the range between the lower limit confidence interval (LLCI = -0.1098) and the upper limit confidence interval (ULCI = 0.1914) for the interaction including zero.

The Moderation Effect of Gender on the Relationship between Attitude and Responsibility

The possible moderation effect of gender on the relationship between attitude and responsibility was investigated using moderation analysis. Figure 4 presents the related conceptual model and the equation of the analysis is given below:

$$\text{Responsibility} = i + c_1 \text{Attitude} + c_2 \text{Gender} + c_3 \text{Attitude} * \text{Gender}$$

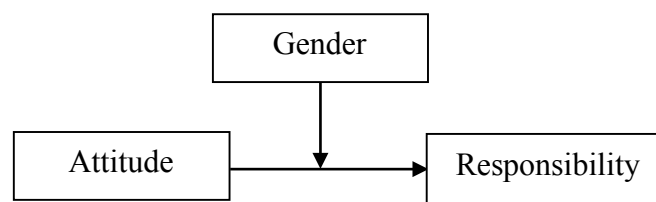

Figure 4. Conceptual model of the moderation analysis

As shown in statistical models (Figure 5), the paths are; 1-) from the independent variable to the dependent variable, 2-) from the moderator variable to the dependent variable, and 3-) from the interaction (attitude*gender) to the dependent variable.

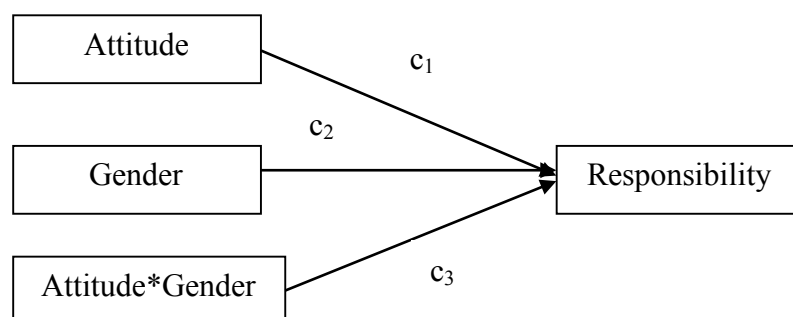

Figure 5. Statistical model of the moderation analysis

In this statistical model, the estimate of c_3 was not statistically different from zero, which means that the effect of attitude was not dependent, at least linearly, on gender. If c_3 was significantly different from zero, we would conclude that the effect of attitude depended on gender. Table 8 gives the results from the PROCESS analysis examining the moderation effect of gender on the relation between attitude and responsibility.

Table 8.

Results of the moderation analysis

		<i>Coeff.</i>	<i>SE</i>	<i>t</i>	<i>p</i>
Intercept	i_1	75.479	0.169	447.012	<.001
Attitude (X)	c_1	0.846	0.061	13.772	<.001
Gender (M)	c_2	-0.101	0.372	-0.272	.786
Attitude*Gender (XM)	c_3	-0.103	0.128	-0.801	.423
$R^2=0.244$, $MSE=46.425$ $F(3, 1631)=64.954$, $p<.001$					

The regression coefficient for XM was -0.103 and was not statistically different from zero with $t(1631)$ being -0.801 and p being 0.423. Therefore, the effect of attitude on responsibility did not depend on gender. In other words, the relationship between attitude and responsibility was not different in females and males. The non-significant moderation effect of gender on the relationship between attitude and responsibility is also observed from the PROCESS output, which gives the range between the lower limit confidence interval (LLCI = -.3550) and the upper limit confidence interval (ULCI = .1492) for the interaction including zero.

Discussion and Conclusions

We began with an ambitious question, “how to remedy environmental education”. We were inspired by the claims asserting that affective components of environmental

literacy are the key to define a person as inevitably environmentally literate. Our purpose was to explore the effect of attitude on the other affective dimensions of environmental literacy; namely environmental concern and responsibility. We used the mediation analysis to explore the effect of environmental attitude on the relationship between the variables of environmental concern and environmental responsibility. In addition, we used the moderation analysis to determine the effect of gender on the relationship between environmental concern and environmental responsibility, and between attitude toward environment and environmental responsibility.

As a result, we found that attitude had a significant mediating effect on the relationship between concern and responsibility. We can, therefore, conclude that attitude is one of the major components that determine operational environmental literacy. Although this is not a new finding, it is important in terms of displaying the mediating effect of attitude. It is not sufficient to consider the direct effects of internal and external factors to explain pro-environmental behaviour; the mediating effects also need to be explored. As shown in the present study and also reported by Kollmuss and Agyeman (2002), the biggest positive influence on pro-environmental behaviour is achieved when internal and external factors act synergistically.

Our findings related to PTs' scores on attitude, concern and responsibility items demonstrate the mediating effect of attitude on concern and responsibility. Although the PTs in this study had high attitudes scores, they seemed to be undecided when asked about the interrelation between human and nature. Yet, their environmental concern was mainly with regard to the problems of national concern. They perceived the global problems as the results of/reasons for the national ones, which indicate that there is a further interrelation/s between affective/internal factors. In other words, PTs in this study were not sure about the relationship between human and nature and this uncertainty resulted in their environmental concern being limited to the problems that they personally experienced. Accordingly, their responsibility towards the environment was similar. When asked whether they agreed to the statement, "Wild animals that provide meat for people are the most important species to protect", 36 % remained undecided. Thus, the way PTs in this study "*read*" the environment can be the result of a cultural/social construct rather than a scientific one, and according to our results, this is mediated by their attitude.

We also tested the moderating effect of gender on the relationships between environmental concern and responsibility, and between attitude and responsibility, and found that these relationships did not differ in females and males. Previous research describing gender as an agent causing difference in values, behaviour, beliefs, attitudes, concern, pro-environmental views (Stern et al., 1993; Xiao & McCright, 2015) and vulnerability to risk (Bord & O'Conner, 1997) has focused on the effect of gender on the individual variables; however, in this study, we focused on the mediating effect of gender on the relationship between other variables (environmental concern and environmental responsibility). To be precise, although gender makes a difference on attitude, for most of the cases, it does not do so when its effect is questioned with the regard to the relationships between the variables; thus supporting the difference shown by the mediation analysis.

In the literature, a few studies used mediation and moderation analyses in education and/or environmental education (e.g. Tarrant, Bright, & Cordell, 1997; Vaske & Kobrin, 2001). Yet, to our knowledge, there is no research investigating the mediating effect of attitude on the relationship between environmental concern and environmental responsibility, and the moderator effect of gender on the variables of environmental literacy. We, therefore, suggest that mediation and moderation analyses are useful to explore the interrelations between environmental literacy variables and further research should be conducted on other variables, particularly to explore the mediating

effect of knowledge on attitude. Furthermore, considering the changing nature of pro-environmental attitudes depending on current events and variations with age, gender, socioeconomic status, culture, urban-rural residency, religion, worldview, values, personality, experience, education and environmental knowledge, we suggest and encourage further attempts to perform a moderation analysis to explore the effects of the above-mentioned variables on attitude.

In conclusion, we are aware that the results and evaluations of this study are not a complete remedy for environmental education. However, we have proposed an alternative approach to asserting that the affective components of environmental literacy are the key to define a person as inevitably environmentally literate.

Furthermore, through our results we assert that, although we do not entirely deny the importance of cognitive component, affective components of environmental literacy shall be emphasized to define and raise persons inevitably environmentally literate. Because, through our results we added to environmental literacy reserach that, the relationship between environmental concern and responsibility may operate through attitude and consideration of this mechanism help us educators in developing effectiveness of education for sustainable development (ESD). As a matter of fact, the recent research and practice in ESD is in line with our claim. For example through their evaluations on the results project titled "Hello, Spring!" Eelma et al. (2015) reported that, values and attitudes come from childhood and home plays an enormous role in the formation of attitudes and so does school and education. According to the results of the project, the authors claim that nature education improves the quality of life by sharing human values; it helps to develop respect, honesty, compassion, care and responsibility. Through the activities of the project which carry all these values, the development of a remarkable number of children's values and attitudes towards life around us is positively influenced. Similarly, Strode (2015) states that in the current life sytles, education provides sphere of activities where the experience of humanity, society and an individual - knowledge, skills, attitudes and value-orientation in terms of the human him/herself, the human environment and nature - is particularly collected, maintained and distributed. Therefore, education is an intellectual need that has to assist people in maintaining and developing attitude towards values, intellectual values. Thus, according to the author the overall process of upbringing and education shall be value-oriented only in case if we can implement the principle of wholeness or holistics. And as Kõiv (2015) reported in their study to touch the students' values, and offer practical tasks and vary the teaching methods in order to create connections between the students' own lives, their communities and other peoples in different parts of the world. As the author stated, encouraging students to share their thoughts and attitudes and building their current values will have an influence their responsibility for the future, as well as the knowledge or facts they have learned about the World.

All in all, in line with the results of this research we draw out that giving the importance the affective components of environmental literacy deserve promises to develop the efficiency of ESD, thus raising more responsible generations, because as Nicol (2015) wrote "Love has got to do everything".

▪ ▪ ▪

References

- Arnon, S., Orion, N., & Carmi, N. (2014). Environmental literacy components and their promotion by institutions of higher education: An Israeli case study. *Environmental Education Research*. Advance online publication. doi:10.1080/13504622.2014.966656

- Bord, R. J., & O'Connor, R. E. (1997). The gender gap in environmental attitudes: The case of perceived vulnerability to risk. *Social Science Quarterly*, 78(4), 830-840.
- Barrow, R. (1980). *The Canadian curriculum: A personal view*. London, Ontario: University of Western Ontario.
- Bradley, J. C., Waliczek, T. M., & Zajicek, J. M. (1999). Relationship between environmental knowledge and environmental attitude of high school students. *The Journal of Environmental Education*, 30(3), 17-21.
- Cheng, I. N. Y., & So, W. W. M. (2015). Teachers' environmental literacy and teaching -stories of three Hong Kong primary school teachers. *International Research in Geographical and Environmental Education*, 24(1), 58-79.
- Cordano, M., Welcomer, S. A., & Scherer, R. F. (2003). An analysis of the predictive validity of the new ecological paradigm scale. *The Journal of Environmental Education*, 34(3), 22-28.
- Dunlap, R. E., & Van Liere (1978). The new environmental Paradigm: A proposed measuring instrument and preliminary results. *Journal of Environmental Education*, 9(4), 10-19.
- Dunlap, R. R., Van Liere, K. D., Mertig, A. G., & Jones, R. E. (2000). Measuring endorsement of new environmental paradigm: A revised NEP scale. *Journal of Social Issues*, 5(3), 425-442.
- Eelma, T., Muuli, V., Rajasaar, V., Ruusmaa, J. and Tuisk, T. (2015, April). *Project „Hello, Spring!“ - Over 20 years of Values Education through Nature and Environmental Education*. Paper presented at Pathways to the Future: Education for Sustainable Development, Tallinn, Estonia, p.42.
- Erdogan, M., & Ok, A. (2011). An Assessment of Turkish Young Pupils' environmental literacy: A nationwide survey. *International Journal of Science Education*, 33(17), 2375-2406.
- Esa, N. (2010). Environmental knowledge, attitude and practices of student teachers. *International Research in Geographical and Environmental Education*, 19(1), 39-50.
- Fraenkel, J. R., & Wallen, N. E. (2006). *How to design and evaluate research in education* (6th ed.). New York: McGraw-Hill.
- Gardner, Howard (1999). *The Disciplined Mind: Beyond Facts and Standardized Tests, The K-12 Education That Every Child Deserves*. New York: Simon and Schuster (and New York: Penguin Putnam).
- Goldman, D., Assaraf, O. B. Z., & Shaharabani, D. (2013). Influence of a non-formal environmental education programme on junior high school students' environmental literacy. *International Journal of Science Education*, 35(3), 515-545.
- Goldman, D., Yavetz, B. & Pe'er, S. (2006). Environmental literacy in teacher training in Israel. *Environmental Behavior of New Students*, 38(1), 3-22.
- Hayes, A. F. (2012). PROCESS: A versatile computational tool for observed variable mediation, moderation, and conditional process modeling [White Paper]. Retrieved from <http://www.afhayes.com/public/process2012.pdf>
- Hayes, A. F. (2013). *Introduction to mediation, moderation, and conditional process analysis: A regression-based approach*. New York: The Guilford Press.
- Hungerford, H., Peyton, R., & Wilke, R. (1980). Goals for curriculum development in environmental education. *The Journal of Environmental Education*, 11(3), 42-47.
- Hsu, S. J (2004). The effects of an environmental education program on responsible environmental behaviour and associated environmental literacy variables in Taiwanese college students. *The Journal of Environmental Education*, 35(2), 37-48.

- Hsu, S., & Roth, R. E., (1998). An assessment of environmental literacy and analysis of predictors of responsible environmental behaviour held by secondary teachers in the Hualien Area of Taiwan. *Environmental Education Research*, 4(3), 229-249.
- Hsu, S., & Roth, R. E., (1999). Predicting Taiwanese secondary teachers' responsible environmental behaviour through environmental literacy variables. *The Journal of Environmental Education*, 30(4), 11-18.
- Hungerford, H. R. & Volk, Y. (1990). Changing learner behaviour through environmental education. *Journal of Environmental Education*, 35(2), 37-48.
- Kaplowitz, M. D., & Levine, R. (2005). How environmental knowledge measures up at a Big Ten university. *Environmental Education Research*, 11, 143-160.
- Kollmuss, A., & Agyeman, J. (2002). Mind the Gap: Why do people act environmentally and what are the barriers to pro-environmental behaviour? *Environmental Education Research*, 8(3), 239-260.
- Kõiv, I. (2015, April). *Why should they care?* Paper presented at Pathways to the Future: Education for Sustainable Development, Tallinn, Estonia, p.64.
- Marcincowski, T. (1991). The relationships between environmental literacy and responsible environmental behaviour in environmental education. In M. Maldague (Ed.), *Methods and techniques for evaluating environmental education*. Paris: UNESCO.
- McBeth, W., & Volk, T. (2009). The national environmental literacy project: A baseline study of middle grade students in the United States. *The Journal of Environmental Education*, 41(1), 55-67.
- McMillan, E., Wright, T., & Beazley, K. (2004). Impact of university-level environmental studies class on students' values. *The Journal of Environmental Education*, 35(3), 19-28.
- Milfont, T. L., & Duckitt, J. (2010). The environmental attitudes inventory: A valid and reliable measure to assess the structure of environmental attitudes. *Journal of Environmental Psychology*, 30, 80-94.
- Nicol, R. (2015, April). *What's love got to do with it? Probably everything*. Paper presented at Pathways to the Future: Education for Sustainable Development, Tallinn Estonia, p.29.
- Pe'er, S., Goldman, D., & Yavetz, B. (2007). Environmental literacy in teacher training: Attitudes, knowledge, and environmental behaviour of beginning students. *The Journal of Environmental Education*, 39(1), 45-59.
- Roth, C. E. (1968). *On the Road to Conservation*, 38-41. Massachusetts: Audubon.
- Roth, C. E. (1992). *Environmental literacy: Its roots, evolution, and directions in the 1990s*. Columbus, OH: ERIC/CSMEE.
- Shephard, K., Harraway, J., Lovelock, B., Skeaff, L. S., Strack, M., Furnari, M., & Jowett, T. (2014). Is the environmental literacy of university students measurable? *Environmental Education Research*, 20(4), 476-495.
- Stables, A., & Bishop, K. (2001). Weak and strong conceptions of environmental literacy: Implications for environmental education. *Environmental Education Research*, 7(1), 89-97.
- Stern, P. C., Dietz, T., Kalof, L. (1993). Value Orientations, gender, and environmental concern. *Environment and Behaviour*, 25, 322-348.
- Strode, I. (2015, April). *Highlighting the value prototyper of modern young people in the context of sustainable education and development*. Paper presented at Pathways to the Future: Education for Sustainable Development, Tallinn, Estonia, p.62.
- Tarrant, M. A., Bright, A. D., & Cordell, H. K. (1997). Attitudes toward wildlife species protection: Assessing moderating and mediating effects in the value-attitude relationship. *Human Dimensions of Wildlife: An International Journal*, 2(2), 1-20. doi: 10.1080/10871209709359091

- Tsevreni, I. (2011). Towards an environmental education without scientific knowledge: an attempt to create an action model based on children's experiences, emotions and perceptions about their environment. *Environmental Education Research, 17*(1), 53-67.
- UNESCO-UNEP (1989). Environmental Literacy for all. *Connect, 15*(2), 1-2.
- UNESCO-UNEP (1977). *Intergovernmental Conference on Environmental Education in Tbilisi*, (USSR) Columbus.
- United Nations Millennium Declaration (2000). *Resolution adopted by the General Assembly. 55/2*.
- Vaske, J. J., & Kobrin, K. C. (2001). Place attachment and environmentally responsible behavior. *The Journal of Environmental Education, 32*(4), 16-21. doi: 10.1080/00958960109598658
- Xiao, C., & McCright, A. M. (2015). Gender differences in environmental concern revisiting the institutional trust hypothesis in the USA. *Environment and Behavior, 47*(1), 17-37.
- Yavetz, B., Goldman, D., & Pe'er, S. (2009). Environmental literacy of pre-service science teachers in Israel: A comparison between students at the onset and end of their studies. *Environmental Education Research, 15*(4), 393-415.

Duyuşsal Faktörlerin Çevre Okuryazarlığına Etkileri: Aracı ve Etkileşim Değişkenleri İle Model Testi

Nilay ÖZTÜRK*

Middle East Technical University

Gaye TEKSÖZ

Middle East Technical University

Özet

Bu çalışmanın amaçları 1- öğretmen adaylarının çevreye yönelik tutumlarının çevreye yönelik kaygı ve sorumluluk değişkenleri arasındaki ilişki üzerinde aracı bir etkisinin olup olmadığını ve 2- cinsiyet değişkeninin çevreye yönelik kaygı ve sorumluluk ile çevreye yönelik tutum ve sorumluluk ilişkileri üzerinde etkileşiminin olup olmadığını araştırmaktır. Çalışmanın veri toplama aracı olan Çevre Okuryazarlığı Anketi toplamda 1626 öğretmen adayına uygulanmıştır. Çalışmanın sonuçları göstermiştir ki, öğretmen adaylarının çevreye yönelik tutumları, çevreye yönelik kaygı ve sorumluluk değişkenleri arasındaki ilişki üzerinde anlamlı bir aracı etkiye sahiptir. Bunun yanı sıra, etkileşim analizlerinin sonuçlarına göre, cinsiyet değişkeninin çevreye yönelik kaygı ve sorumluluk değişkenleri ile çevreye yönelik tutum ve sorumluluk değişkenleri arasındaki ilişkiler üzerinde anlamlı bir etkileşimi yoktur.

Anahtar Kelimeler: Çevre okuryazarlığı, tutum, çevreye yönelik sorumluluk, cinsiyet, aracı değişken analizi, etkileşim değişkeni analizi.

The Determination of Cognitive Structure of Candidate Teachers About Energy Centrals

Kadir KARATEKIN*

Kastamonu University, Kastamonu, Turkey

Ersin TOPÇU

Kastamonu University, Kastamonu, Turkey

Bahattin AYDINLI

Kastamonu University, Kastamonu, Turkey

To cite this article: Karatekin, K., Topçu, E. & Aydınli, B. (2016). The determination of cognitive structure of candidate teachers about energy centrals. *International Electronic Journal of Environmental Education*, 6(2), 76-91.

Abstract

Energy is the vital essence of every biotic and abiotic process. Energy is also in central position in human civilization. The famous energy centrals are the major way for production of energy with many diverse effects on environment. Therefore, the mitigation of these effects is extremely important and one of its way is education in this controversial issue. The aim of this study is to investigate the cognitive structure of these candidate teachers with various branches towards energy centrals or power plants in the road of the solution of the environmental problem. They were asked to fill the word association test containing four major concepts, nuclear, hydroelectric, thermal and wind centrals. In sum, the nuclear central and wind central are found to be the most and the least dangerous ones sequentially in cognitive structure.

Keywords: Candidate teacher; word association test; energy centrals; cognitive structure

Introduction

Energy is one of the most abstract concepts in science, education and daily life. It concerns many fields from academia to politics and science to media. It is simply defined as the ability to do work. It can be stored in material form and generally transmitted by electricity and radiation. The environmental pollution exerted meanwhile of these process is another issue. Energy conversions are possible, but the produced energy should be used immediately otherwise it is wasted as heat. The heat is the ultimate dead form of the energy which adds the global warming. Thus energy should be used efficiently before transforming into heat. The main topics are sustainable energy production, transportation and storage. The sustainability concept here bears also keeping delicate balance of the Earth. Environmental pollution with intrinsic and non-intrinsic hazardous material are prime issues. For example, carbon dioxide (CO₂) intrinsically nonhazardous compound but accumulation of it in the atmosphere nowadays is the major concern of global warming which can cause climate change. On the other, nitrogen oxides known as NO_x which are produced in every combustion process basically fossil fuels, are intrinsic hazardous material. The nitrogen oxides and sulfur oxides are responsible for acid rain which forms in the atmosphere with chemical reaction with water. The water when contaminated with toxic material becomes the basic material in the dissemination of toxicity. Also the nuclear energy embedded in the

radioactive elements naturally starts to threaten the humanity and the world. Basically, when the uranium (^{235}U) enriched it can start to decay and produce energy, and the end results in residual dangerous waste. The other renewable and nonrenewable energy resources should also be evaluated carefully. Because, the energy resources which seems safe today may be found to be dangerous in the future.

The people of postmodern society had used to consume energy in easy and smart manner on time in luxury mode. We have to make choice whether we will continue to consume non renewable energy sources and/or find alternative and sustainable energy sources or we will change our habits and reduce energy consumption. Both of the conditions open exciting track to humanity. Anyway we have to try to find the solutions for every type energy problem. The discussion can be based on the interrelations of the subjects with energy, economy, sociology, ecology, citizenship and education.

The one of the main problem lies in the deficiency of communications between governmental organization and education system. All governments keep as secret of their energy demands and supply, because, they are strategic information and cannot be disseminated through public awareness and even in academia. If we are living in the same and one world, it cannot be monopolized by one authority whether it can be a group, a country or whatsoever.

The energy has started to play important role in the development of civilizations through its usage in steam engine with burning of fossil fuels in the last decades of 18th century in Europe (Küçükkalay, 1997; Griffin, 2011). Meanwhile, after the discovery of machine which produce electricity (by Michael Faraday in 1831), the pioneering primitive form of hydroelectric central resembling the today's one has started to be used in England after 50 years (Mallick, 2012). These conditions let the concepts of energy and electricity to become synonyms in public. From now on, the electricity unexceptionally becomes the autonomous power of science, technology and industry, and comfortable life. With the imagination of nonexistence of electricity, the humanity would have returned back to middle age. The increasing demand of energy due to increased population and technological devices triggers the consumption of fossil based energy resources (oil, coal, natural gas) which bring global warming and environmental pollution, probably resulting in climate change in future (Dinçer & Aslan, 2008; Keçebaş, Gedik & Kayfeci, 2010; MEB, 2012). Inevitably, these environmental issues take concern of public and none renewability of these resources towards the government alternative sources in last decades (Türkyılmaz, 2010). Nowadays, the specialists declare that oil, natural gas and coal will be depleted approximately in 40, 60 and 150 years respectively (Türkyılmaz, 2007; Aydın, Tonguz & Yılmaz, 2013). In these conditions, it is inevitable to use alternative sources in case availability. This differentiation starts in 19th century and fastens and takes priority meanwhile (Mallick, 2012).

Today, the sources energy centrals which generate electricity have been differentiated, and take the names of renewable and nonrenewable as distinct categories. In this context, while the renewable energy sources are flow potentials of water, solar radiation, biomass, wind, geothermal water, tides and waves, and hydrogen which have the potentials of existing tomorrow in natural cycle of mature with lesser hazardous to nature and human, the nonrenewable ones are fossil based fuels namely; oil, coal and natural gas along with uranium and thorium which have the higher potentials to damage them (Çakar, Başaran Filik & Kurban, 2009; Koç & Şenel, 2013; Yakıcı, Ayan & Papuçcu, 2013).

The popularity of renewable energy sources gaining acceleration due to lesser damaging effect of them to environment. However, the technologies related to them are newer and widespread usage is limited yet. Anyhow, some of the governments made formal legislation and politics towards them by 2009. Presently, the ratio of renewable

energy for supply of energies for OECD countries and world are 5.2 % and 2.1 % consequently. And, the investment in this sectors increases rapidly especially in developed countries (Kum, 2009).

Renewable energy centrals both have positive and negative effecting ways. For instance, hydroelectric centrals have low production cost of electricity after the construction of dam. And it adds economy like irrigation, fishery and tourism. However, since the electricity production depend on precipitation amount, the deterioration of the habitat near the water basin of the dam in order to collect water, and submerging of many historic and touristic places can be counted as main negative points of the hydroelectricity central. Wind centrals do not harm the environment during construction and it can be constructed in suitable places, but the storage cost is very high. The nuclear centrals have high construction cost, but the production cost of electricity is rather low. Normally, it does not harm environment other the problem of storage of nuclear waste. God forbid, in the case of accident, the destructive effect may continue decades apparently. Nuclear centrals do not cause air pollution and contribute a good and powerful image to country which can be counted as positive dimensions (URL 1 & URL 2). Fossil fuel plants low cost electricity due to the ample amount of the raw materials. However, it pollutes considerably water, earth and air (Goncaloğlu, Ertürk & Ekdal, 2000). In a result, renewable or not all centrals have hazardous effects on environment (Ertürk, Akkoyunlu & Varınca, 2006; Ürker & Çobanoğlu, 2012).

Among these energy centrals, the deep debate is continuing on nuclear ones (Altın, 2004). The debate has started with Chernobyl and continue with Fukushima Daiichi (Stoutenborough, Sturgess & Vedlitz, 2013). Society does not have enough knowledge about energy centrals especially nuclear ones, and they prefer renewable sources rather than fossil fuels and nuclear based centrals (Lee, Hu & Chang, 1999; Aydın, Coşkun, Kaya & Erdönmez, 2011; Lee & Yang, 2013; Kim, 2013; De Groot, Steg & Poortinga, 2013; Kenar, 2013; Arikawa, Cao & Matsumoto, 2014; Haşiloğlu, 2014; Charisiou, Goula, 2014).

The transformation of knowledge into behavior about environmental issues is lacking back compared other areas of education in worldwide (Kuhlemeier & et al, 1999; Kibert 2000; Owens, 2000; Murphy, 2002; Pe'er, Goldman & Yavetz (2007); Puruçuoğlu, 2008; Erdoğan, 2009; Altınöz, 2010; Mcbeth & Volk, 2010; Esa, 2010; Timur, 2011). The people do not aware the incoming environmental dangers before occurring the inevitabilities. Also, the students growing in technologically developed post-cosmopolitan cities do not find chance to investigate natural and unnatural events like food chain and energy production plants. Environmental protection on the hand of insensitive people is difficult to achieve. Therefore, the determination of the cognitive structure of the people which results in attitude and behavior is important.

Nowadays, the word association test (WOT) has been started to be used in mapping cognitive structure of the concepts in human brain.

Kostava & Radoynovska (2008) have summarized the word association in contemporary way. Word association is a powerful research technique, introduced by Galton in 1880. Carl Jung theorized that people connect ideas, feelings, experiences and information by way of associations. According to him, ideas and experiences are linked, or grouped, in the unconscious in such a manner as to exert influence over the individual's behavior. A great work was ascribed to educators who can influence the human brain at very early stages that results in right connections and behavior is a test, consisting of a list of words, administered to the respondent, who has to answer to each word by means of the first word coming to his or her mind

By this way, a conceptual cognitive structure can be developed according to frequency table of the words cited by questioned people. This frequency table is quantized with numbers such as 10 etc. to obtain cognitive maps at various complexity and levels. The human brain has layered, divided and complex structure. The WOTs are promising in generalization of the cognitive structure.

In this structure, WOTs are one of the alternative measurement and evaluation technique. It is used to reveal the cognitive structure of the students where the concepts interconnected satisfactorily in long term-memory or not (Bahar, 2003). WOTS are not used only to determine cognitive structure of the students but also detection of the concept misconception and transformations of the concepts before and after execution of the training of the students (Işıklı & et al., 2011; Polat, 2013). This technique is used mainly for scientific concerns but also used for social issues (Deveci, Köse, & Bayır, 2014; Işıklı & et al., 2011; Bahar ve Kılıç, 2001).

The aim of this study is to outburst the disability of the candidate teachers in cognitive skills through energy centrals to reach satisfactory perceptions of energy centrals. This will supply many feedbacks. First of all, it will play a vital role in determination of the academic education affectivity of the candidate teachers in this controversial issue. Beside this, it will give some clues what they have learned and perceived about energy centrals (Han, Kim & Choi, 2014). The revelation of the cognitive structure of them can supply us how will probably teach these controversial subjects in the future. The revitalization of the individuals about energy issues has ultimate importance in terms of science, technology, society, and environment. One of the effective way to achieve this goal pass through education in schools.

Methodology

The Research Model

The survey model was used in this study. It is a descriptive statistical analysis to define the situation as exist (Karasar, 1999). By this way, the cognitive structure of candidate teachers has been tried to be revealed by word association test (WOT) about energy centrals.

Sample

The study has been executed by 78 candidate teachers with various branches (social, science and class teachers) in education faculty of Kastamonu University in 2014-2015 academic year in Turkey. These branch teachers are responsible in teaching about energy issues. The distribution of participants according to gender and branches were given in Table 1.

Table 1.

The distribution of participants according to gender and branches

Branches	Gender		Total
	Female	Male	
Elementary class teachers	19	7	26
Science teachers	19	7	26
Social science teachers	11	15	26
Total	49	29	78

Data Collection

WOT was used as data collection tool. The energy centrals which are the subject of this study are related with both science and social science. The nuclear, hydroelectric, thermal and wind energy centrals are chosen as key concepts for this study. All of these concepts were written covering the whole page separately as shown in the following.

Nuclear Central:.....

Nuclear Central:.....

Nuclear Central:.....

Before the application of the WOT to students, they were informed about it and a sample application was done as pretreatment with another concept. Then, one minute is given to each concept for students to write out the words that they think about any relation with these key concepts.

Analysis of the Data

The frequency table showing the repetition frequency of the words that were produced by the candidate teachers about the concepts was given in App 1. By using this frequency table, concept networks were driven to depict cognitive structure of the students towards energy centrals by using cutting point techniques which is developed by Bahar et al. (1999). In this technique, a certain amount of number is subtracted from most cited words to determine the cutting point. The most cited word is energy in this study as 61 counts. Since there are a few words counted between 61 and 30 times, 30 is fixed as first cutting point. The concepts lying above this point were written on the first section of the concept network. Consequently, by counting down by tens from first cutting point till appearing new concepts, the process was continued on concept network (Bahar & Özatlı, 2003). The frequency of words which are cited less than 9 were not used in construction of concept network due to virtual difficulty, but given in frequency table.

Findings

If frequency table is examined, it is seen that total 165 words were used by candidate teachers in their response to WOT about the key concepts. The distribution of these words throughout the energy centrals was given in Table 2.

Table 2.

The # words produced by candidate teachers related with key concepts

Key Concepts	Positive word Counts	f	Negative word Counts	f	Total word Counts
Nuclear Central	59	331	50	302	109
Hydroelectric Central	49	511	6	24	55
Thermal Central	35	325	11	69	46
Wind Central	33	396	4	17	37
		80			

The key concept of nuclear central was associated with highest number of words (109) by candidate teachers, and least one is the wind centrals by 37 words. The number of words interrelated with hydroelectric and thermal centrals are 55 and 46 sequentially which are quite lower than the nuclear central one. This may be interpreted as the candidate teachers have developed cognitive structure on nuclear centrals. At the same time, they relate it with negative words at highest number (50) which is supported by highest frequency of these words (302). Even so, they have associated this nuclear central concept with science, technology, economy and politics which are rather positive words. In sum, they hesitate about it. Meanwhile, it is the wind central that was interrelated with least number of negative words (4)

The # of negative words about thermal central and their frequency is low and thermal, hydroelectric and wind central have similar values in table 2 in comparison with nuclear central. This can be a significant finding. They associate thermal central key concept with earthquake, fault line, thermal spring and hot water. This means that they probably confuse the thermal central and geothermal energy which may result in less number of negative associated words to thermal central which burns fossil fuels (coals and natural gas) which releases hazardous by products to environment. The term air pollution caused by thermal centrals only cited by 9 teacher candidate support this finding.

It has proven that hydroelectric centrals have many diverse effects to environment. Yet, the participants associated it lower number of negative words (6) which may show that they have weak cognitive structure toward it.

The concept networks prepared according to cutting points are in the following two figures; figure 1 and figure 2. The concept network belonging to the cutting point 30 and above is shown in figure 1.

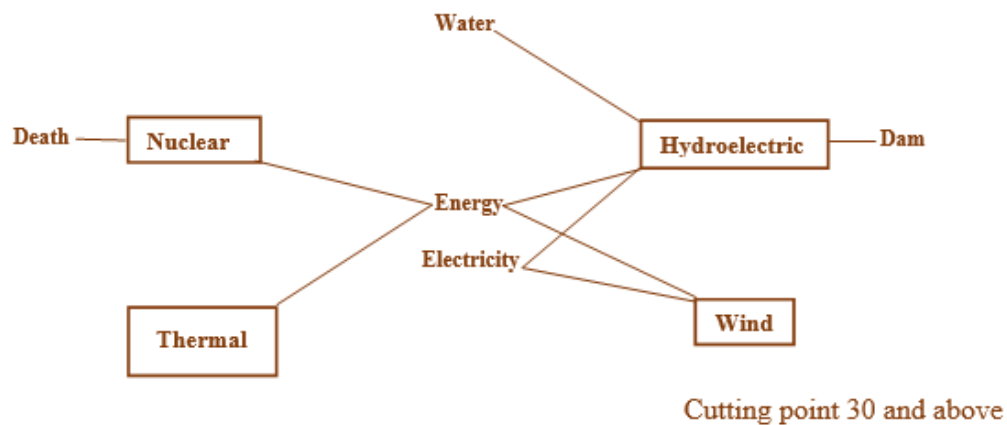

Figure 1. The concept network belonging to the cutting point 30 and above

As seen in Fig. 1, all the key concepts were outburst at cutting points 30 and above where all the key concepts were associated with energy word. Whereas the word electricity was only associated with hydroelectric and wind centrals. The association of the word death with nuclear central clearly shows the negative aspects of participants towards nuclear central in their cognitive structure. The association of hydroelectric central with such familiar words water and dam, and no association existence of thermal

and wind centrals with any words apparently show that their deficiency in their cognitive structure towards these three centrals.

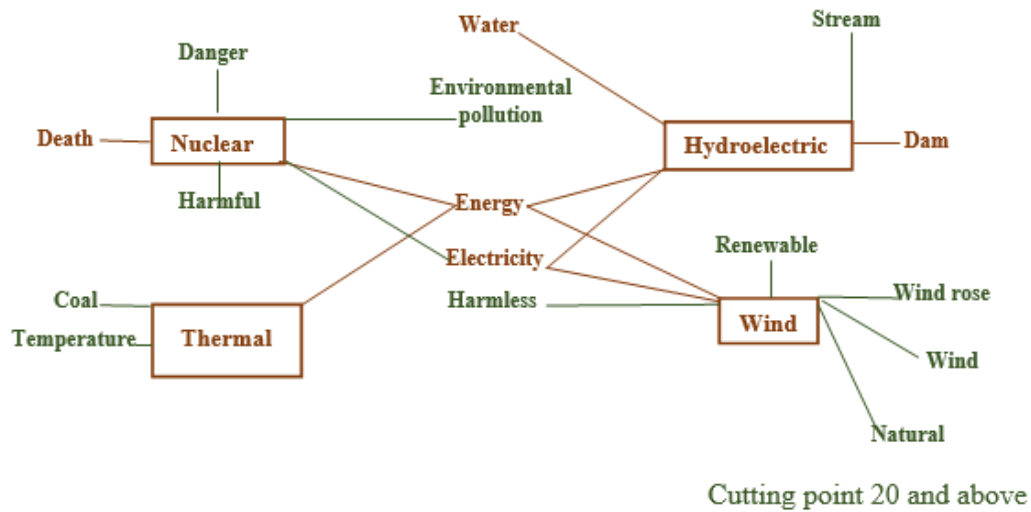

Figure 2. The concept network belonging to the cutting point 20 and above

It is seen that the # of associated words has increased with reduced cutting number (20). However, no words other than energy and electricity have appeared that was associated with four of the key concepts at this cutting point. The words associated with nuclear central are again negative ones such as dangerous, harmful and environmental pollution. Thermal central was only associated with the words coal and temperature. Wind central was associated by the word renewable 27 out of 78. Hydroelectric central was not related with the word renewable. Especially, it can be stated wind central is safe contrary to nuclear central in cognitive structure of the participants.

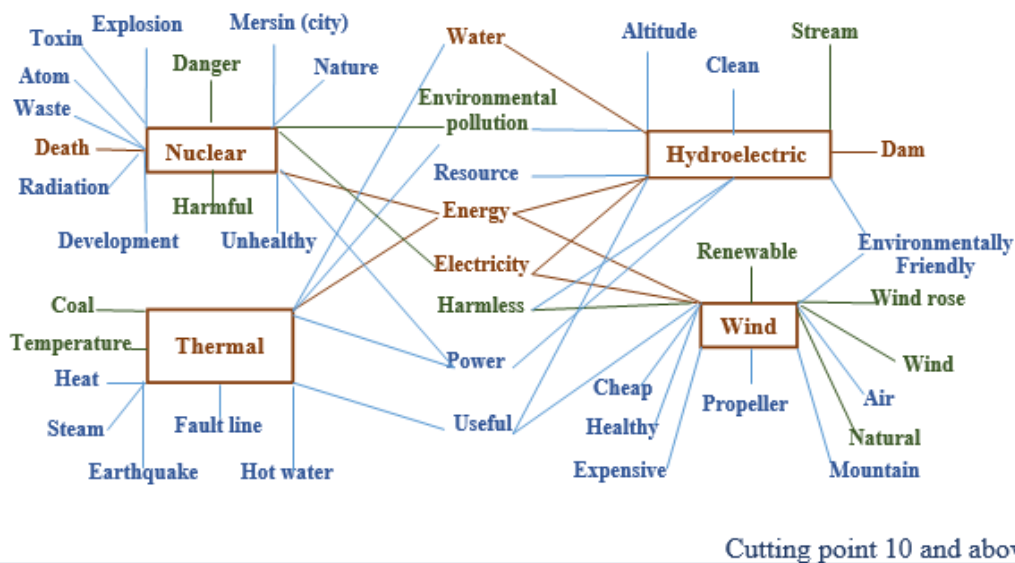

Figure 3. The concept network belonging to the cutting point 10 and above

Naturally, at cutting point 10 and above lots of words appeared that was associated with four key concepts. The association of environmental pollution with thermal and hydroelectric centrals only appeared at this stage which shows weak connections and cognitive structure of the candidate teachers towards these two centrals. They perceive the hydroelectric and wind centrals as harmless. At this point, new negative words appeared for nuclear central such as waste, explosion and unhealthy. And the association of thermal central with hot water, fault line, earthquake and hot spring imply that they have misconceptions about them.

Results and Discussion

The energy production is the most important human dwelling which affects the nature and environment. The energy production scale should be determined according to needs of society and the resources and technologies of the country. Also, governments should consider the delicate balance between human and environment. The society directs the politics of the governments and people should be educated thoroughly and accordingly. The school or educational system is the basic arguments. The educational system, sustained by teachers can be effective in preserving the aforementioned balance consistent with the realities of locally and globally. This could be achieved by eco-centric perspective in energy education rather than anthropocentric approach. In this study, the positions of the energy centrals in cognitive structure of teacher candidates are quite different and unfortunately not satisfactory for efficient energy education.

The nuclear central which is absent yet but in construction stage in Turkey, was associated the highest amount of negative words. This may indicate negative situation in their cognitive structure. The extreme debate on nuclear central in media especially after catastrophic failure of Fukushima nuclear central in Japan may cause this result. It seems that candidate teachers are completely unaware about the technology of nuclear central. As they thought that nuclear central cause environmental pollution more than thermal central and this is contrary to reality under normal circumstances. In addition to this, they have related the words the asthma, air pollution and fume with nuclear centrals which show weakness of them. They also cite the words science, technology, economy and politics under key concept of nuclear central which show discrepancy in their cognitive structure (Lee, Hu & Chang, 1999; Özdemir, Kurt & Yapıcı, 2009; OECD, 2010; Aydın, Coşkun, Kaya & Erdönmez, 2011; Lee, & Yang, 2013; Kim, 2013; De Groot, Steg & Poortinga, 2013; Kenar, 2013; Charisiou & Goula, 2014; Özdemir, 2014; Arikawa, Cao & Matsumoto, 2014; Haşiloğlu, 2014).

The candidate teachers have associated energy centrals with rather simple words, and inadequate knowledge and misconceptions. This shows that they are deficient in teaching these subjects. They have associated electricity with only wind and hydroelectric central about at 30 cutting point and above. This shows their lacking in cognitive structure for nuclear and thermal central. Because the prime structure in their cognition was associated with diverse effects of accidents rather than production of electricity and their technology of nuclear centrals. Also, Ausebel (1963) has also defined the cognitive structure hierarchically where the general concepts take positions up and goes down with less generals (cited from Uçak & Güzeldere, 2006). The speculating the nuclear central accidents during teaching process would let students to attaining negative attitude toward it, consequently resulting in the opposing citizen to nuclear central. And this could affect the energy politics of government eventually.

Like nuclear central, the thermal central has also associated with electricity in lesser amount. Probably, they confused the thermal and geothermal adjectives and/or

concepts which were evoked by associating the words fault line, earthquake, hot water and thermal springs with thermal central. The expected words are air pollution, acid rains, global warming, asthma, heart attack etc. which were not cited; confirm their weakness of cognitive structure, similarly in Bozkurt & Koray (2002).

The wind and hydroelectric energy centrals take the position as the least harmful and environmentally friendly ones in their cognitive structure. Also, at cutting points 10 and above, these centrals were not associated with negative words other than the association hydroelectric central with environmental pollution. In addition to these, just 27 and 7 candidate teachers sequentially have associated these centrals with renewable energy which indicate the weak relations of electricity with these resources in cognitive structure. These show that the candidate teachers are unaware about the diverse effects of especially hydroelectric centrals such as extinction of species, perturbation of natural life and deterioration of socioeconomic structure etc. (Akkaya et al., 2009). Beside these, science education candidate teachers have associated hydroelectric central with decrease in biodiversity, and social science education candidate teachers have related it with immigration, history and erosion of cultural heredity which show again their adequacy in their teaching of these subjects. This means that even their approach is affirmative towards these two energy centrals, they have limited knowledge and also misconceptions, similarly in (Bilen, Özel & Sürücü, 2013; Saraç & Bedir, 2014).

In sum, civic people should be cultivated handling the environmental and energy issues in holistic manner. And this only can be achieved by multidisciplinary and interdisciplinary education perspectives which rely on not only economic constraints but also ecological, sociological, biological, political and geographical issues which compromise both scientific sociological developments. By do way, society will be cleared by a chicken and egg situation even it does not produce alternative solution to problems, but shades the brilliant ideas.

• • •

References

- Akkaya, U., Gültekin, A.B., Dikmen, Ç.B. & Durmuş, G. (13-15 Mayıs, 2009). Baraj ve hidroelektrik santrallerin (HES) çevresel etkilerinin analizi: ılısu barajı örneği, *5. Uluslararası İleri Teknolojiler Sempozyumu, (IATS'09)*, Karabük Üniversitesi, Türkiye.
- Altın, V. (2004). Yeni ufuklara nükleer enerji. *Bilim ve Teknik*. TÜBİTAK.
- Altınöz, N. (2010). *Fen bilgisi öğretmen adaylarının çevre okuryazarlık düzeyleri*, Yayınlanmamış Yüksek Lisans Tezi, Sakarya Üniversitesi Fen Bilimleri Enstitüsü, Sakarya.
- Arikawa, H., Cao, Y. & Matsumoto S. (2014). Attitudes toward nuclear power and energy-saving behavior among japanese households. *Energy Research & Social Science*, 2, 12-20.
- Aydın, D.S. Tonguz, A. & Yılmaz, Ö.M. (2013). Nükleer enerji 2023 yılında dünyanın en büyük ilk 10 ekonomisi arasında yer almayı hedefleyen Türkiye Cumhuriyeti'nin enerji ihtiyacına çare olabilir mi?

- http://tedprints.tedankara.k12.tr/429/1/Damla_Su_Aydin-Omer_Mert_Yilmaz.pdf (08.06.2015 tarihinde edinilmiştir).
- Aydın, F., Coskun, M., Kaya, H. & Erdönmez, İ. (2011). Gifted students' attitudes towards environment: a case study from Turkey. *African Journal of Agricultural Research*, 6 (7), 1876-1883.
- Bahar, M. (2003). Biyoloji eğitiminde kavram yanlışları ve kavram değişim stratejileri. *Kuram ve Uygulamada Eğitim Bilimleri / Educational Sciences: Theory & Practice*, 3 (1), 27-64.
- Bahar, M., Johnstone, A.H. & Sutcliffe, R.G. (1999). Investigation of students' cognitive structure in elementary genetics through word association tests. *Journal of Biological Education*, 33, 134-141.
- Bahar, M. & Kılıç, F. (Haziran, 2001). Kelime iletişim testi yöntemi ile Atatürk ilkeleri arasındaki kavramsal bağların araştırılması. *IX. Eğitim Bilimleri Kongresi*, Abant İzzet Baysal Üniversitesi, Bolu.
- Bahar, M. & Özatlı, N.S. (2003). Kelime iletişim test yöntemi ile lise 1. sınıf öğrencilerinin canlıların temel bileşenleri konusundaki bilişsel yapılarının araştırılması. *BAÜ Fen Bilimleri Enstitüsü. Dergisi* 5 (2), 75-85.
- Bilen, K., Özel, M. & Sürücü, A. (2013). Fen bilgisi öğretmen adaylarının yenilenebilir enerjiye yönelik tutumları. *Dumlupınar Üniversitesi Sosyal Bilimler Dergisi*, (36), 101-112
- Bozkurt, O. & Koray, Ö. C. (2002). "İlköğretim öğrencilerinin çevre eğitiminde sera etkisi ile ilgili kavram yanlışları". *Hacettepe Üniversitesi Eğitim Fakültesi Dergisi*, (23), 67-73.
- Charisiou N.D. & Goula M.A. (2014). Attitudes of Greek university students towards energy and the environment. *Global Nest Journal*, 16 (5), 856-865.
- Çakar, M.C., Başaran Filik, Ü. & Kurban, M. (2009). Yenilenebilir enerji kaynakları ve ulaşım sistemlerinde kullanım uygulaması. *V. Yenilenebilir Enerji Kaynakları Sempozyumu*, Diyarbakır.
- De Groot, J.M., Steg, L. & Poortinga, W. (2013). Values, perceived risks and benefits and acceptability of nuclear energy; *Risk Analysis*, 33 (2), 307-317.
- Deveci, H., Köse-Çengelci, T. & Bayır-Gürdoğan, Ö. (2014). Öğretmen adaylarının sosyal bilimler ve sosyal bilgiler kavramlarına ilişkin bilişsel yapıları: kelime ilişkilendirme testi uygulaması. *Adıyaman Üniversitesi Sosyal Bilimler Enstitüsü Dergisi*, 7 (16), 101-124.
- Dinçer, M.Z. & Aslan, Ö. (2008). *Sürdürülebilir kalkınma, yenilenebilir enerji kaynakları ve hidrojen enerjisi: Türkiye değerlendirmesi*. İTO. Yayın No: 2009-51.
- Ertürk, F., Akkoyunlu A. & Varınca, K.B. (2006). Enerji üretimi ve çevresel etkileri fosil hidrolik yenilenebilir nükleer. *TASAM Stratejik Rapor*. No: 14.
- Erdoğan, M. (2009). Fifth grade students' environmental literacy and the factors affecting students' environmentally responsible behaviors, Unpublished Doctoral Dissertation, The Graduate School of Social Sciences Middle East Technical University.
- Esa, N. (2010). Environmental Knowledge, Attitude and practices of student teachers. *International Research in Geographical and Environmental Education*, 19 (1), 39-50.

- Goncaloğlu, B.İ., Ertürk, F. & Ekdal, A. (2000). Termik santrallerle nükleer santrallerin çevresel etki değerlendirmesi açısından karşılaştırılması. *Ekoloji Çevre Dergisi*, 9 (34) 9-14.
- Griffin, E. (2011). The mechanical age: technology, innovation and industrialization https://www.academia.edu/991318/A_Short_History_of_the_British_Industrial_Revolution_Palgrave_2011 (accessed 08.06.2015)
- Han, E.O., Kim, J.R.,& Choi, Y.S. (2014). Korean students' behavioral change toward nuclear power generation through education. *Nuclear Engineering and Technology*, 46 (5), 707-718.
- Haşiloğlu, M.A. (2014). The examining of prospective teachers' views about renewable and non-renewable energy sources: a case study of Turkey. *Academic Journals*, 9 (13) 411-416.
- Işıkli, M., Taşdere, A. & Göz, N. L. (2011). Kelime ilişkilendirme testi aracılığıyla öğretmen adaylarının Atatürk İlkelerine yönelik bilişsel yapılarının incelenmesi. *Uşak Üniversitesi Sosyal Bilimler Dergisi*, 4 (1), 50-72.
- Karasar, N. (1999). *Bilimsel araştırma yöntemi*, Ankara: Nobel Yayınları.
- Keçebaş, A., Gedik, E. & Kayfeci, M (2010). Fosil yakıtların kullanımından kaynaklanan hava kirliliği üzerine jeotermal enerji ve doğalgaz kullanımının etkisi: Afyon örneği, *Makine Teknolojileri Elektronik Dergisi*, 7 (3), 23-30.
- Kenar, İ. (2013), Nuclear energy reality in Turkey and the attitude of the science teachers towards the issue. *Kamla-Raj. Anthropologist*, 16 (1-2), 153-165.
- Kibert, C. N. (2000). *An Analysis of the correlations between the attitude, behavior, and knowledge components of environmental literacy in undergraduate university students*. Unpublished Master Dissertation, The Graduate School of the University of Florida, USA.
- Kim, M. (2013). Risk communication about nuclear power in Korea: one-year descriptive analysis on twitter. *Science Education International*, 24 (3), 324-343.
- Koç, E. & Şenel, M. C. (2013). Dünyada ve Türkiye'de enerji durumu - genel değerlendirme. *Mühendis ve Makina*, 54(639), 32-44.
- Kostova, Z. & Radoynovska, B. (2008). Word association test for studying conceptual structures of teachers and students. *Bulgarian Journal of Science and Education Policy (BJSEP)* 2(2), 209-231.
- Kuhlemeier, H., Bergh, V.D. H. & Lagerweij, N. (1999). Environmental knowledge, attitudes, and behavior in Dutch secondary education. *The Journal of Environmental Education*, 30 (2), 4-14.
- Kum, H. (2009). Yenilenebilir enerji kaynakları: dünya piyasalarındaki son gelişmeler ve politikalar, *Erciyes Üniversitesi İktisadi ve İdari Bilimler Fakültesi Dergisi*, (33), 207-223.
- Küçükkalay, A. M. (1997). Endüstri devrimi ve ekonomik sonuçlarının analizi. *Süleyman Demirel Üniversitesi İktisadi İdari Bilimler Fakültesi Dergisi*, (2), 51-68.
- Lee, C., Hu, S., & Chang, W. P. (1999). *A study on risk perception toward nuclear power operation in Taiwan*. Institute of Public Health, and Institute of Environmental Health Sciences, National Yang-ming University, Taiwan

- Lee, L., Yang, H. (2013). Technology teachers' attitudes toward nuclear energy and their implications for technology education. Online Submission, <http://files.eric.ed.gov/fulltext/ED545402.pdf>. (accessed 06.05.2015).
- Mcbeth, W. & Volk, T. (2010). The national environmental literacy project: a baseline study of middle grade students in the United States, *The Journal of Environmental Education*, 41 (1), 55-67.
- Mallick, A. (2012). History and Present Technological development in electrical energy sector, *Steam Boiler*, 6 (7), 25-27.
- MEB. (2012). *Hava kirliliğine etki eden kaynaklar. Aile ve tüketici hizmetleri*, Ankara: http://megep.meb.gov.tr/mte_program_modul/moduller_pdf/%C3%87evre%20Hizmetleri.pdf. (accessed 06.05.2015).
- Murphy, T.P. (2002). *The Minnesota report card on environmental literacy*. Hamline University, Center for Global Environmental Education. (ERIC Reproduction Service No. ED 474505)
- OECD. (2010). Public attitudes to nuclear power, nuclear energy agency organisation for economic co-operation and development. <https://www.oecd-nea.org/ndd/reports/2010/nea6859-public-attitudes.pdf>. (accessed 07.06.2015).
- Owens, M.A. (2000). *The environmental literacy of urban middle school teachers*. Unpublished Doctoral Dissertation, Faculty of the Graduate School of Emory University, USA.
- Özdemir, N. (2014). Sosyo bilimsel esaslar çerçevesinde sosyo bilimsel konuları tartışmak tutumları nasıl etkiler? nükleer santraller. *Turkish Studies - International Periodical for The Languages, Literature and History of Turkish or Turkic*, 9 (2), 1197-1214.
- Özdemir, Ö.Ö., Kurt, A.Ö. & Yapıcı, G. (2009). Mersin ilinde görev yapan hekimlerin sağlık ve çevre boyutuyla nükleer enerjiye bakış açılarının değerlendirilmesi. <http://www.phd.org.tr/14kongresunum/bildiri/2.ppt>. (accessed 08.06.2015).
- Pe'er, S., Goldman, D. & Yavetz B. (2007). Environmental literacy in teacher training: attitudes, knowledge, and environmental behavior of beginning students, *The Journal of Environmental Education*, 39 (1), 45-59.
- Polat, G. (2013). 9. sınıf öğrencilerinin çevreye ilişkin bilişsel yapılarının kelime ilişkilendirme test tekniği ile tespiti. *Necatibey Eğitim Fakültesi Elektronik Fen ve Matematik Eğitimi Dergisi (EFMED)* 7 (1), 97-120.
- Purutçuoğlu, E. (2008). Üniversite öğrencilerinin demografik özellikleri ve materyalist eğilimleri ile çevreye yönelik tutum ve davranışları arasındaki ilişkinin incelenmesi, Yayınlanmamış Doktora Tezi, Ankara Üniversitesi Fen Bilimleri Enstitüsü, Ankara.
- Saraç, E. Bedir, H. (2014). Sınıf öğretmenlerinin yenilenebilir enerji kaynakları ile ilgili algılamaları üzerine nitel bir çalışma. *KHO Bilim Dergisi*, 24 (1), 19-45.
- Stoutenborough, J.W., Sturgess S.G. & Vedlitz, A. (2013). Knowledge, Risk, and Policy Support: Public Perceptions of Nuclear Power. *Energy Policy*, 62, 176-184.
- Timur, S. (2011). *Fen bilgisi öğretmen adaylarının çevre okuryazarlık düzeylerinin belirlenmesi*, Yayınlanmamış Doktora Tezi, Gazi Üniversitesi Eğitim Bilimleri Enstitüsü, Ankara.

Türkyılmaz, O. (2007). Dünyada ve Türkiye'de enerji sektörünün durumu. *Mühendis ve Makine*, 48 (569), 69-77.

Türkyılmaz, O. (2010). Türkiye'nin ve Dünyanın enerji profili <http://www.yildiz.edu.tr/~okincay/dersnotu/EnerjiProfili.pdf> (accessed 08.05,2015)

Uçak, N.Ö. & Güzeldere, Ş.O. (2006). Bilişsel yapının ve işlemlerin bilgi arama davranışı üzerine etkisi, *Türk Kütüphaneciliği*, 20 (1), 7-28.

Ürker, O. & Çobanoğlu, N. (2012).Türkiye'de hidroelektrik santrallerin durumu (hes'ler) ve çevre politikaları bağlamında değerlendirilmesi. *Ankara: Ankara Üniversitesi Sosyal Bilimler Enstitüsü Dergisi*, 3(2), 65-88.

Yakıcı Ayan, T. & Pabuçcu, H. (2013). Yenilenebilir enerji kaynakları yatırım projelerinin analitik hiyerarşi süreci yöntemi ile değerlendirilmesi. *Süleyman Demirel Üniversitesi İktisadi ve İdari Bilimler Fakültesi Dergisi*, 18.(3), 89-110.

URL 1. <http://www.epa.gov/cleanenergy/energy-and-you/affect/nuclear.html>. (accessed 15.06.2015).

URL 2. <http://www.physics.isu.edu/radinf/np-risk.htm>. (accessed 18.06.2015).

Appendix

The Frequency Table of the Words Associated with Energy Centrals by Candidate teachers.

Word Counts	Words	Energy Central				Word Counts	Words	Energy Central			
		Nuclear	Hydroelectric	Fossil Fuel	Wind			Nuclear	Hydroelectric	Fossil Fuel	Wind
1	Aegean region			8		49	England	1			
2	Agriculture		4			50	Environmental Damage	2		1	
3	Air	3			16	51	Environmental pollution	29	10	13	
4	Air pollution	8		9		52	Environmentally friendly		8		15
5	Airlessness	2				53	Expensive	1	5		10
6	Alaçatı				8	54	Explosion	12			
7	Altitude		14		7	55	Factory	8	2	6	
8	Asthma	4				56	Fault line			12	
9	Atatürk dam		4			57	Filter			1	
10	Atom	10				58	Fire	1			
11	Atomic bomb	4				59	Flow		9		
12	Balıkesir				2	60	Flow rate		6		
13	Black Sea	2				61	Forest	1			
14	Bomb	5				62	Fossil fuel			1	
15	Brown coal			5		63	France	1			
16	Cancer	10				64	Fuel	1			
17	Cheap		7	3	16	65	Fume	4		5	
18	Chemicals	6				66	Garbage	1			
19	Chemistry	1				67	Geology	1			
20	Chernobly	8				68	Geopolitics	2			
21	Child	3				69	Harmful	21	5	6	
22	China	1				70	Harmful substance	1			
23	Clean		13	5		71	Harmless		10	6	27
24	Climate		3			72	Hazardous radiation	2			
25	Coal	3		21		73	Healthy		9	6	10
26	Consumption	2				74	Heat	5		16	
27	Controversial	2				75	Hot water			18	
28	Cripple	3				76	Human	6	3		
29	Çanakkale				3	77	Industry	6	2	4	
30	Dam	5	40			78	Iron	1			
31	Danger	27		1		79	Income	4	5		
32	Death	33				80	Irrigation		4		
33	Deficient				4	81	Japan	12			
34	Deforestation		2			82	Kazım Koyuncu	1			
35	Developed country	6				83	Lake		4		
36	Development	18	7	2		84	lasting				3
37	Disabled	1				85	Life		6		
38	Disaster	7				86	Manufacture	5	13	9	8
39	Disease	7		3		87	Mersin	9			
40	Distribution		3			88	Metal	1			
41	Earthquake	1		13		89	Mineral	2		4	
42	East Blacksea		5			90	Money	7		5	3
43	Eastarnian region		7			91	Mountain		4		12
44	Economical	1	3	1		92	Mutation	3			
45	Economy	5	7	5	6	93	Natural		9	6	20
46	Electricity	25	56	23	36	94	Natural gas			2	
47	Employment	9				95	Natural resource	1			
48	Energy	61	58	61	54	96	Nature	12	6	5	7

Word Counts	Words	Energy Central				Word Counts	Words	Energy Central			
		Nuclear	Hydroelectric	Fossil Fuel	Wind			Nuclear	Hydroelectric	Fossil Fuel	Wind
97	Necessary	1				148	U.S.A	3			
98	Nederland				3	149	Underground resource			8	
99	Need	7	3			150	Unhealthy	10	1	1	
100	Negation	1				151	Unrenewable	2		5	2
101	Noise	1			1	152	Uranium	6			
102	Physics	4				153	Useful		13	13	15
103	Politics	1				154	War	4			
104	Pollution	9				155	Waste	10			
105	Poor soil	2				156	Water	12	57	11	
106	Power	11	10	10	5	157	Water pollution	1	1		
107	Powerfull	1				158	Water power		8		
108	Pressure				2	159	Weapon	1			
109	Profit	1				160	Wind				28
110	Propeller				12	161	Wind rose				24
111	Protest	6				162	Wind turbines				3
112	Radiation	18				163	Windmill				8
113	Radioactive substance	2				164	Worry	5			
114	Rainfall		7			165	Zonguldak			4	
115	Ray	1					Total	109	55	46	37
116	Reactor	1									
117	Regime		2								
118	Renewable		7	5	27						
119	Resource	3	11	9	3						
120	Risk	1									
121	Roid food	1									
122	Roughness		6								
123	Russia	4									
124	Safe	1			2						
125	Saving	4	9	4	7						
126	Science	6									
127	Sea	4	3								
128	Security	4									
129	Sinop	8									
130	Soil pollution	2									
131	Southeastarnian region		3								
132	Speciality	1									
133	Speed		4								
134	Steam			10							
135	Steep terrain		6								
136	Stone	1									
137	Strategic	1									
138	Stream		25								
139	Tea	2									
140	Technology	9	4		2						
141	Temperature			21							
142	Thermal springs			7							
143	Tourism		2								
144	Toxin	11									
145	Trade	1									
146	Trouble	1									
147	Turbine				2						

Öğretmen Adaylarının Enerji Santralleri Hakkındaki Bilişsel Yapılarının Belirlenmesi

Kadir KARATEKİN*

Kastamonu Üniveristesi, Kastamonu, Türkiye

Ersin TOPÇU

Kastamonu Üniveristesi, Kastamonu, Türkiye

Bahattin AYDINLI

Kastamonu Üniveristesi, Kastamonu, Türkiye

Özet

Her türlü işlemin olmazsa olmaz bileşeni olan enerji, insan medeniyetinde başrodedir. Meşhur enerji santralleri de çevreye zit etkileriyle beraber enerji üretiminin başlıca yoludur. Çok tartışılan bu konuda, zararlı etkilerin hafifletilmesi ve ılımlaştırılması çok önem arz etmektedir ve bunun bir yolu da eğitimden geçmektedir. Bu çalışma kapsamında, çevresel problemlerin çözümüne giden yolda, farklı branşta öğretmen adaylarının enerji santralleri üzerine zihin yapıları incelenmiştir. Adaylardan, dört ana kavram olan nükleer, hidroelektrik, termik ve rüzgâr santralleri ilgili kelime ilişkilendirme testini doldurmaları istenmiştir. Sonuç olarak zihin yapılarında, nükleer santral en tehlikeli ve rüzgâr santrali en az tehlikeli olarak bulunmuştur

Anahtar Kelimeler: Öğretmen adayı, kelime ilişkilendirme testi, enerji santralleri, bilişsel yapı.

Environmental literacy in Madeira Island (Portugal): The influence of Demographic Variables

Hélder SPÍNOLA*

The University of Madeira, Funchal, PORTUGAL

To cite this article: Spinola, H. (2016). Environmental literacy in Madeira Island (Portugal): The influence of demographic variables. *International Electronic Journal of Environmental Education*, 6(2), 92-107.

Abstract

Demographic factors are among those that influence environmental literacy and, particularly, environmentally responsible behaviours, either directly or due to an aggregation effect dependent on other types of variables. Present study evaluates a set of demographic variables as predictors for environmental literacy among 9th grade students from Madeira Island (Portugal). Through a survey involving 491 students, gender, place of residence (rural and urban), 8th grade Natural Sciences discipline performance, participation in school's environmental activities and, indirectly, socio-economic status were evaluated in their association to environmental literacy and, particularly, to each of its three main components: knowledge, attitude and behaviour. The results confirm three stronger environmental literacy predictors: rural or urban residence, depending on the components considered, higher marks in 8th grade Natural Sciences discipline and higher socio-economic status; and two weaker: female and participation in school's environmental activities. Our findings found support in previous studies and underline the need to center socio-demographic factors in environmental education practices. Considering demographic variables as the reflex of environmental, economic and socio-cultural contexts, our results corroborate an environmental literacy's construction framework on the light of Vygotsky's socio-cultural theory of human learning, in which real learning contexts play a fundamental role. In fact, also in environmental literacy, learning occurs through the interaction with the social environment and, to be effective, needs real learning contexts. Demographic variables confirmed as being predictors for environmental literacy in Madeira Island students seems to mirror the effects of the above framework and show strong evidences of linkage with socioeconomic status.

Keywords: Environmental Education, Environmental Literacy predictors, Demographic Variables, Madeira Island

Introduction

Environmental literacy has a long way as the environmental education main purpose and is also an important prerequisite to maintain and improve the quality of the environment (Disinger & Roth, 1992). However, increasing environmental literacy in a target population is a very hard task since it's a process where a profusion of different factors act in an interdependently and complex way and the outcome results are difficult to predict (Hollweg et. al., 2011). Despite there is a lack of empirical research addressing the pathway through which environmental literacy is formed, as also on the effectiveness of environmental education (Keene & Blumstein, 2010), several models and frameworks have been proposed to explain environmental literacy and the adoption of environmental friendly behaviours (Hsu, 1997).

Disinger and Roth (1992) suggested that environmental literacy was essentially the capacity to perceive and interpret the relative health of environmental systems and

take appropriate action to maintain, restore, or improve the health of those systems. Later, Wilke (1995, pp. 5-6) defined four clusters of environmental literacy components: cognitive dimensions (knowledge and skill), affective dimensions, additional determinants of environmentally responsible behaviour, and personal and/or group involvement in environmentally responsible behaviour.

Nowadays, is of common understanding that environmental literacy must include knowledge and understanding of environmental concepts, problems, and issues, a set of cognitive and affective dispositions, and a set of cognitive skills and abilities, together with the appropriate behavioural strategies to apply such knowledge and understanding in order to make sound and effective decisions in a range of environmental contexts (Hollweg et. al., 2011). As a simple definition, environmental literacy could be seen as a domain of four interrelated components: knowledge, dispositions, competencies, and environmentally responsible behaviour (Hungerford & Volk, 1990; Hollweg et. al., 2011).

Evaluating environmental literacy in a population is the best strategy to assess the efficiency of the environmental education efforts, as also to address the needs for better strategies. However, there is a lack of evaluation, especially with before-after or treatment-control designs, and some authors even identify a “bunker mentality” to explain the resistance of the environmental community on evaluating projects and strategies on the field (Blumstein & Saylan, 2007). Additionally, environmental literacy has a complex structure that makes difficult include all their components in any single assessment, being of fundamental importance identify the essential elements to be addressed in the survey. In order to overcome this problem, several authors identified knowledge, attitude and environmentally responsible behaviour as the major components of the environmental literacy to be included in the surveys (Krnel & Naglič, 2009; McBeth & Volk, 2010; Kuhlemeier, et. al., 1999).

Besides evaluating environmental literacy levels among specific young or adult groups, identifying the variables that behave as predictors for overall and specific dimensions of environmental literacy is critical since they could enlighten the process underneath its construction (Palmer, 1999). Demographic factors are among those that influence environmental literacy and, particularly, environmentally responsible behaviours, not only through a direct influence but specially due to an aggregation effect dependent from other types of variables (Kollmuss & Agyeman, 2002).

Several categorical and demographic variables, such as age, gender, income, residence and parental education level, have been commonly investigated and found to be predictors for environmental literacy levels (Erdoğan, 2009). Older (Tikka et al., 2000), higher grade (Kellert, 1985; Shin et al., 2005), males (Gifford et al., 1982/83), urban residence (Kellert, 1985), and higher income and parental higher levels of education (Shin et al., 2005) tend to predict higher environmental knowledge. However, a better environmental attitude has been linked to younger (Bogner & Wiseman, 1997), female (Gifford et al., 1982/83), urban residence (Bogner & Wiseman, 1997), higher socioeconomic status (SES) (Lyons & Breakwell, 1994) and parental higher levels of education (Shin et al., 2005). For environmentally responsible behaviour, younger, female and higher income are the most frequently associated to better results (Hines et al. (1986/87).

Few studies evaluated environmental literacy among Portuguese students, or in other specific groups and overall population (Author, 2014). These studies address mostly knowledge and attitude toward the environment and some considers also the influence of categorical and demographic variables as predictors for environmental literacy (Almeida & Azeiteiro, 2011; Cordeiro, 2010; Pedro, 2009; Câmara, 2014). Despite with some limitations on the analysis and statistics, especially because they didn't apply

significance tests to statistically support their findings, these studies showed that, among 12th grade students of some specific mainland Portuguese schools, higher environmental knowledge tends to be associated to female in a urban school (Cordeiro, 2010) and to male in a rural (Almeida & Azeiteiro, 2011), to parental higher education levels (Cordeiro, 2010; Almeida & Azeiteiro, 2011), to rurality (Almeida & Azeiteiro, 2011), and to the participation on environmental activities in a urban school (Cordeiro, 2010). Female in 2 urban schools (Cordeiro, 2010; Almeida & Azeiteiro, 2011), lower parental education level in both urban (Cordeiro, 2010) and rural schools (Almeida & Azeiteiro, 2011), and rural schools (Almeida & Azeiteiro, 2011) has been associated to better attitude levels toward the environment on these 12th grade Portuguese students.

In Madeira Island (Portugal) the studies on environmental literacy are even scarcer. Using the New Ecologic Paradigm (NEP) Scale, an instrument widely used and validated in the measure of pro-environmental orientation (Dunlap et. al., 2000), Freitas (2007) found that, in Madeira Island overall population, younger individuals, from urban areas and with higher education and SES tend to show a higher pro-NEP attitude. Also, the same study concluded that energy and water saving behaviours were most prevalent among individuals with lower education and SES and, in opposition, waste segregation for recycling and green consumption were associated to highest education and SES. Recently, for the first time, studies on the environmental literacy level among 9th grade students from Madeira Island were developed showing, in general, good levels of knowledge, a satisfactory pro-NEP attitude but low prevalence of environmentally responsible behaviours (Author, in press). However, no significantly better results were found for those students engaged in Eco-Schools Program, an international environmental education project in place in the majority of the educational establishments from Madeira Island, being an important next step in this approach the evaluation of categorical and demographic variables in order to address their influence as predictors for environmental literacy.

Research Questions

Since previous studies among Madeira Island 9th grade students showed that the levels of environmental literacy found doesn't depend necessarily on the environmental education project "Eco-Schools Program" (Author, in press), other variables need to be evaluated as a contribution to better understand the pathway through which environmental literacy develops in the specificities of Madeira Island context. In this sense, present study addresses the following research questions:

Are gender, learning achievement levels on the 8th grade Natural Sciences discipline, area of residence (urban or rural) and participation in environmental activities predictors of environmental literacy for 9th grade students from Madeira Island (Portugal)? And what are its specific influences in each of the three considered dimensions of environmental literacy, namely knowledge, attitude and behaviour?

Therefore, we hypothesized that:

- 1- Female students show better knowledge, attitude and behaviours toward the environment;
- 2- Students with better marks in 8th grade Natural Sciences discipline show better knowledge, attitude and behaviours toward the environment;
- 3- Students from urban areas show better knowledge, attitude and behaviours toward the environment;
- 4- Students that participate in school's environmental activities show better knowledge, attitude and behaviours toward the environment.

Methodology

The survey design was based in others published elsewhere but adjusted to local specificities (Kuhlemeier, et. al., 1999; Krnel & Naglič, 2009; McBeth & Volk, 2010). It was anonymous with close-ended questions consisting of a header and three main sections, each one measuring and assessing: knowledge (10 questions), attitude (15 questions) and environmentally responsible behaviour (15 questions) (questionnaire available upon request). The questionnaire header includes gender, marks in 8th grade Natural Sciences discipline and participation in environmental activities. Urban or rural residence was taken from the school location since student lives around. Data on student's social support and parental education levels were used to characterize the SES of the 9th grade students from the biggest school involved on the present research. Knowledge section addressed the 3 main themes developed in environmental education activities on Portuguese schools: water (3 questions), energy (3 questions), and wastes (4 questions); each one going along 3 main aspects: cause of problems, regional context and behaviour options. To measure pro-environmental attitude the questionnaire included the New Ecologic Paradigm (NEP) Scale, an instrument widely validated in the measure of pro-environmental orientation (Dunlap et. al., 2000; Trobe & Acott, 2000; Kostova et. al., 2011; Shoukry et. al., 2012). The environmentally responsible behaviours were assessed through statements spanning across the 3 main themes already selected for knowledge: water (4 statements), energy (6 statements) and wastes (5 statements). Each statement addressed specific everyday behaviours and students were asked to select their frequency in a Likert-type scale ranging from 1 (never) to 5 (always). A special care was taken to overcome potential social desirability bias that could overcome in self-reported assessments (Nederhof, 1985). In order to obtain an internal validity indicator, two redundant questions ["a) I put paper, glass bottles and plastic bags in different containers" and j) "I put all kind of wastes in the same container"] were added. The questionnaire was pre-tested and the final version was applied to all sample students between April and May 2013, after informed consent from each school board.

The sample included 491 9th grade students from 5 elementary schools from Madeira Island (Portugal). Data collected in the survey was analyzed with SPSS (version 20) statistical software. Firstly, reliability (the Cronbach's Alpha score was 0.705 for the entire measuring instrument) and validity (confirmed by factor analysis and internal validity indicator questions that show a significant positive correlation [$r=0.641$ $p=0.000$]) were evaluated followed by a set of descriptive statistics.

Variables (gender, marks in Natural Sciences, participation in environmental activities and place of residence) were compared for each of the three data domains: knowledge, attitude and behaviour. To test our hypothesis, significance was addressed through one sample z-test of proportions (1-tailed) with a confidence level of 95%.

Results

The 491 9th grade students involved in this survey had a mean age of 15 years and males (51.3%) are slightly most prevalent than females (48.7%). More than two thirds (65%) are from an urban area (Funchal city) and the others (35%) from rural municipalities. Students with higher marks in 8th grade Natural Sciences discipline (4 or more, in a scale of five points) were most prevalent (52.1%) than the others (47.9%, with 3 or less) and only 20.6% admit to had been involved in school's environmental activities along past few years. Missing values account for 3.1% on total sample.

Ninth grade female students showed a better environmental knowledge, especially on wastes theme, and a slightly better attitude towards the environment, with a

significantly lower support of the Dominant Social Paradigm (DSP), and a higher prevalence of environmentally responsible behaviours, particularly for water savings (Table 1). Participation in school's environmental activities seems not to improve the prevalence of environmentally responsible behaviours but show significant positive influences in environmental knowledge, especially on wastes theme, and also in a higher support of the New Ecological Paradigm (NEP), particularly agreeing with the 'possibility of an eco-crisis' (Table1).

Despite gender and participation in environmental activities show some significant influences in environmental literacy, student's area of residence (rural or urban) and, especially, marks in 8th grade Natural Sciences discipline reveal to be important predictors for environmental literacy in Madeira Island 9th grade students (Table 1, Figures 1 and 2). In fact, rural students show significantly better knowledge for water and energy themes, and urban for wastes, and the environmentally responsible behaviours higher prevalence's appear in urban students for water savings and waste management, and in rural for energy savings (especially due to a significantly lower mobility in their parent's car, data not shown). Urban students show also a better attitude towards the environment with a significantly higher concordance with the New Ecological Paradigm (Table 1, Figure 1). However, it was among 9th grade students with better marks (≥ 4) in 8th grade Natural Sciences discipline where present study found higher levels of environmental literacy. Students with better marks showed significantly better environmental knowledge and a higher level of concordance with the New Ecological Paradigm, including each one of its five NEP group items, as also a much lower concordance with the Dominant Social Paradigm. Also, better marks are associated to a significantly higher prevalence of water savings and waste management behaviours, the only exception being for energy savings where students with lower marks (≤ 3) had significantly better results (Table 1, Figure 2). This lower prevalence for energy saving behaviours among students with higher marks results from a significantly higher mobility to school in their parent's car (data not shown). As an important result to understand this behaviour exception is the fact that students with better marks are significantly most prevalent among families with higher SES (Figure 3).

Table 1.

Correct answers prevalence's for environmental knowledge (in total and for each theme: water, energy and wastes); Attitude orientation prevalence's towards the environment for pro New Ecological Paradigm (pro-NEP), pro Dominant Social Paradigm (pro-DSP) and Unsure; Pro-NEP attitude concordance prevalence's for each group item: limits to growth, anti-anthropocentrism, fragility of nature's balance, rejection of exemptionalism, possibility of an eco-crisis; environmentally responsible behaviors prevalence's in an 'always' plus 'very often' basis (in total and for each theme: water, energy and wastes), in 9th grade students from Madeira Island by area of residence (urban and rural), marks in 8th grade Natural Sciences discipline (≤ 3 and ≥ 4), gender (F-female and M-male) and participation in school's environmental activities (EA- participating in environmental activities and NEA- without participation). Statistical significant differences in bold. Sig.- Significance.*

<i>Correct answers prevalence's (%) for environmental knowledge</i>												
<i>Themes</i>	<i>Rural</i>	<i>Urban</i>	<i>Sig.</i>	<i>3</i>	<i>4</i>	<i>Sig.</i>	<i>3</i>	<i>4</i>	<i>Sig.</i>	<i>A</i>	<i>EA</i>	<i>ig.</i>
<i>Water</i>	9.9	3.8	.01	4.3	6.6	.18	4.3	6.9	.15	8.0	4.8	.15
<i>Energy</i>	5.7	0.9	.01	0.0	4.4	.00	2.3	2.4	.48	2.3	2.1	.46
<i>Wastes</i>	0.5	3.3	.00	0.6	4.3	.00	3.6	1.4	.01	4.2	2.1	.03
<i>Total</i>	1.4	1.9	.27	9.8	3.6	.00	2.5	1.2	.04	3.2	1.4	.03
<i>Attitude orientation prevalence's towards the environment</i>												
<i>Orientation</i>	<i>Rural</i>	<i>Urban</i>	<i>Sig.</i>	<i>3</i>	<i>4</i>	<i>Sig.</i>	<i>3</i>	<i>4</i>	<i>Sig.</i>	<i>A</i>	<i>EA</i>	<i>ig.</i>
<i>Pro-NEP</i>	8.5	0.8	.04	7.3	4.7	.00	9.0	7.5	.10	0.4	8.0	.05
<i>Pro-DSP</i>	6.2	6.6	.34	7.5	5.4	.01	7.4	9.6	.01	8.2	8.4	.44
<i>Unsure</i>	5.3	2.6	.01	5.2	9.9	.00	3.6	3.0	.27	1.4	3.7	.03
<i>Pro-NEP attitude concordance prevalence's (%)</i>												
<i>NEP group items</i>	<i>Rural</i>	<i>Urban</i>	<i>Sig.</i>	<i>3</i>	<i>4</i>	<i>Sig.</i>	<i>3</i>	<i>4</i>	<i>Sig.</i>	<i>A</i>	<i>EA</i>	<i>ig.</i>
<i>Limits to growth</i>	2.8	8.1	.00	1.2	3.2	.00	4.7	8.3	.17	8.2	6.2	.55
<i>Anti-anthropocentrism</i>	2.4	2.1	.46	0.8	5.6	.04	4.6	0.1	.06	4.9	3.3	.62
<i>Fragility of nature's balance</i>	7.9	0.2	.20	5.8	4.1	.00	0.5	8.7	.46	4.4	2.6	.59
<i>Rejection of exemptionalism</i>	1.2	0.5	.41	8.4	4.9	.02	2.6	9.9	.31	8.6	7.8	.79
<i>Possibility of an eco-crisis</i>	0.6	2.1	.30	8.6	6	.00	2.6	0.5	.42	5.5	8	.02
<i>Environmentally responsible behavior prevalence's (%) (always + very often)</i>												
<i>Themes</i>	<i>Rural</i>	<i>Urban</i>	<i>Sig.</i>	<i>3</i>	<i>4</i>	<i>Sig.</i>	<i>3</i>	<i>4</i>	<i>Sig.</i>	<i>A</i>	<i>EA</i>	<i>ig.</i>
<i>Water</i>	4.9	1.9	.00	6.7	4.3	.00	1.9	7.6	.03	9.6	0.0	.44
<i>Energy</i>	8.1	1.5	.00	5.8	0.9	.00	9.6	7.4	.10	9.5	8.3	.29
<i>Wastes</i>	1.0	5.1	.03	1.7	7.0	.01	5.3	2.5	.08	4.0	4.2	.47
<i>Total</i>	7.6	8.1	.35	7.3	9.1	.07	9.2	6.7	.02	8.4	8.0	.39

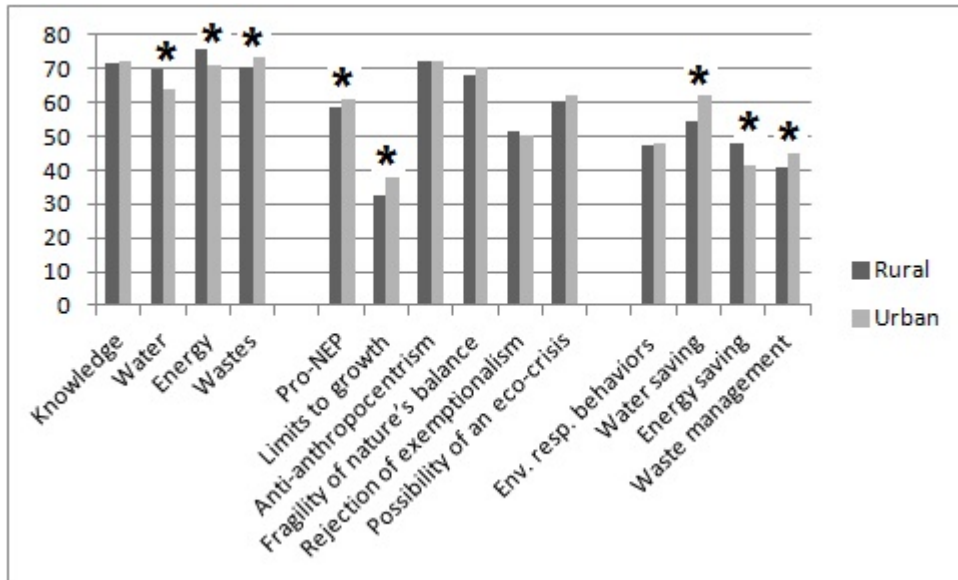

Figure 1. Correct answers prevalence's for environmental knowledge (in total and for each theme: water, energy and wastes); Pro-NEP (pro New Ecological Paradigm) attitude concordance prevalence's in total and for each group item: limits to growth, anti-anthropocentrism, fragility of nature's balance, rejection of exemptionalism, and possibility of an eco-crisis; and environmentally responsible behaviour prevalence's in 'always' plus 'very often' basis (in total and for each theme: water, energy and wastes), in 9th grade students from Madeira Island by area of residence (urban and rural). Statistical significant $p \leq 0.05$ signalled with *.

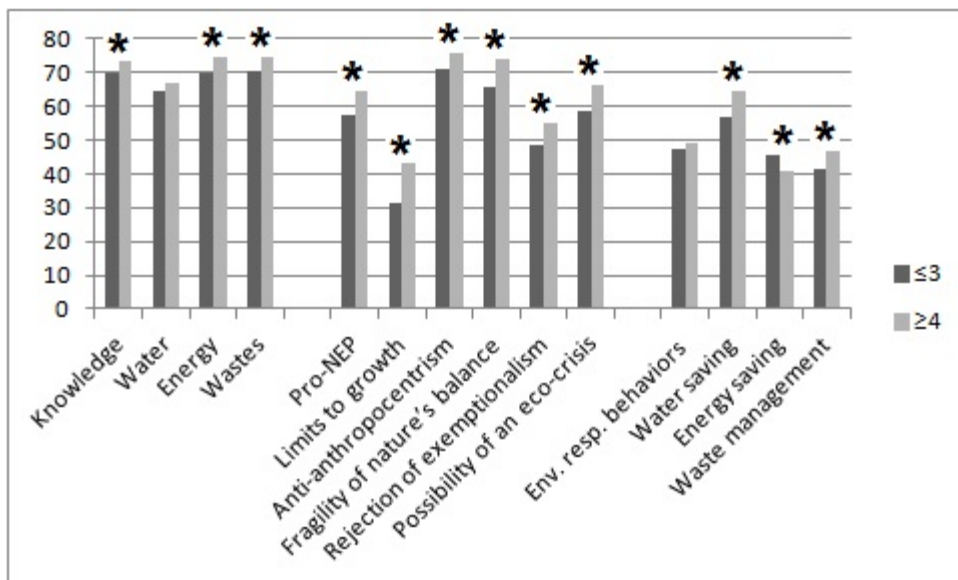

Figure 2. Correct answers prevalence's for environmental knowledge (in total and for each theme: water, energy and wastes); Pro-NEP (pro New Ecological Paradigm) attitude concordance prevalence's in total and for each group item: limits to growth, anti-anthropocentrism, fragility of nature's balance, rejection of exemptionalism, and possibility of an eco-crisis; and environmentally responsible behaviour prevalence's in 'always' plus 'very often' basis (in total and for each theme: water, energy and wastes), in 9th grade students from Madeira Island by marks in 8th grade Natural Sciences discipline (≤3 and ≥4). Statistical significant $p \leq 0.05$ signalled with *.

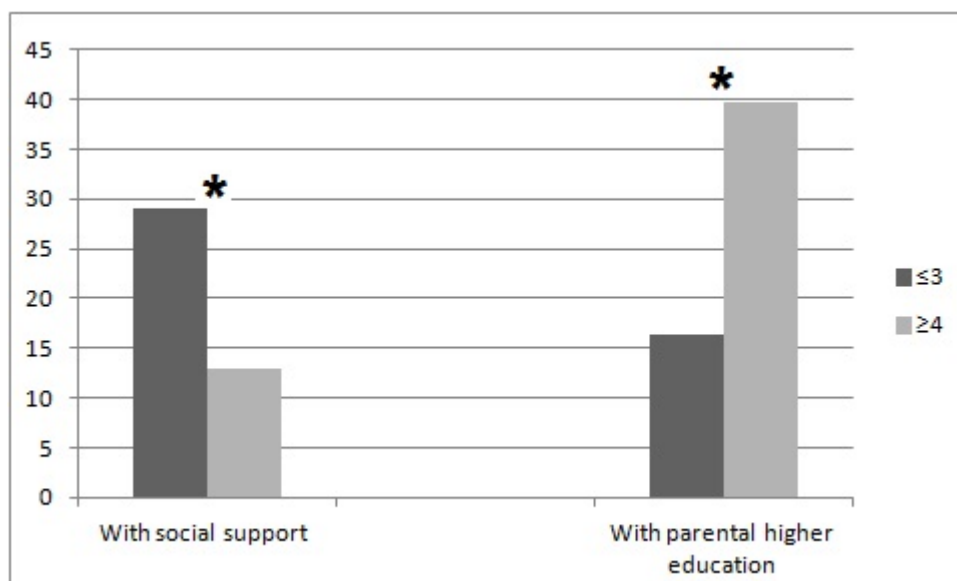

Figure 3. Relationship between socioeconomic indicators (social support and parental higher education) and marks in the 8th grade Natural Sciences discipline (≤ 3 and ≥ 4) for 196 9th grade students from an urban school included in present study. Statistical significant $p \leq 0.05$ signalled with *.

Discussion

The results of present study were successful in identifying strong predictors for overall environmental literacy, as well for each one of its components evaluated (knowledge, attitude and behaviour). Consistently with previous studies, female, participation in environmental activities, rural residence for some aspects and urban for others and higher marks in 8th grade Natural Sciences discipline were positively associated to higher levels of environmental literacy in 9th grade students from Madeira Island (Portugal).

The relationship between education and environmental literacy is well established and a greater understanding of science has been associated to a higher identification with a pro-environmental paradigm (Hamilton, 2008; Shin et al., 2005), which is consistent with the higher environmental literacy levels among students with better performance in Natural Sciences. However, the positive influence of the 8th grade Natural Sciences discipline performance could be an indirect effect of its strong linkage with SES, demonstrated in present study (Figure 3) and elsewhere (Coleman, 1966). In fact, as income and occupational status increase environmental concern tends to be greater (Van Liere & Dunlap, 1980; Shin et al., 2005; Lyons & Breakwell, 1994; Hines et al., 1986/87), in the assumption of a hierarchy of needs in which environmental concerns arise only when basic needs are met (Maslow, 1970). This strong influence of the student's SES had been emphasized by Taylor and colleagues (2009, p. 4) with a very clear statement: "wealthy 'middle class' people have the luxury of the 'privilege of concern', because they have the financial ability to look beyond their own livelihood, explore global issues, and make the connections between the environmental and wealth generations. In contrast, people from lower socioeconomic groups do not have the option of such 'luxury', and it is only when they are involved in a practical and direct way with their local environment that they too can go on to make such connections". Nevertheless, it is of much importance underline that, despite the higher availability for an environmental concern from those who had solved their survival questions, this not always results in environmentally responsible behaviours since the easier access to

resources due to their higher SES implies, frequently, higher consumption levels and, consequently, a heavier ecological footprint. Our results support this analysis since, despite their better levels of environmental literacy, these students from families with higher income tend to consume more energy, especially due to a most frequent car use. Despite an exception on this positive association, the higher car use among students with better marks supports the link between environmental literacy and SES, since we can assume that this unsustainable behaviour could be mostly dependent on the financial resources available in the family than in a lack of the student's environmental motivation. In fact, reducing car use was considered to be subject to high behavioural costs and influenced by strong constraints, namely those with non-environmental motivations such as affective and symbolic factors (Bamberg & Schmidt, 2003; Hunecke et al., 2001). Besides that, in the present situation, the car use among 9th grade students is obviously most dependent on their parent's options than their own, which could explain the incongruence with the general tendency for higher levels of environmental literacy among students with better Natural Sciences marks and higher SES. Still, we can argue that, since Natural Sciences curriculum includes environmental education contents (Tracana et al., 2012), this positive influence on the environmental literacy could be a direct contribution of this particular discipline. An influence in the opposite direction is another way of seeing it, being the higher environmental literacy that influences better marks in Natural Sciences discipline as it was previously demonstrated (Lieberman & Hoody, 1998).

Interestingly are the non linear influences of the student's residence area. The weight of economic and socio-cultural context on this variable could be the reason for the positive effects that both urban and rural residence exerts on environmental literacy, depending on the components we are considering. For example, rural students show a higher prevalence on energy saving behaviours, which is mostly due to a significantly lower mobility depending on their parent's car (e.g. using parents as their chauffeurs to go to school: 31.4% for rural students against 50.8% for urban, in a 'always' and 'very often' basis, $p=0.00$). A similar effect was found with the lowest marks in Natural Sciences discipline, which is also dependent on a lower socio-economic status (see above). Knowing that the results of present study reveals that urban students had significantly better marks in Natural Sciences discipline than rural (marks ≥ 4 : 55.2% for urban students against 43.7% for rural, $p=0.013$), this similar effect could be in fact, again, a direct influence of SES, especially if we take in account that average family income tends to be lower in urban areas. However, socio-economic status shouldn't be the only influence on energy saving behaviours, namely in mobility, since rural students also show a significantly better knowledge in this same specific theme, which can't be explained through the linkage 'better socio-economic status - higher marks' because rural showed lower marks than urban. Another example supporting the idea that the predictor 'area of residence' could be in fact a pool of contexts that differently influence the components of the environmental literacy, are the results obtained for waste knowledge and behaviours. In this specific theme, both knowledge and environmentally responsible behaviours are most prevalent among urban students, which could be explained with the fact that Funchal city has a better and most dynamic system on waste management. In fact, Funchal, since the middle of the 1990s, put in place consistent environmental campaigns and a waste management system with three-stream collection for recycling, which could be the driver for today's urban students be more informed and participative. Also, the incongruent influence of urban and rural residence on water theme, with better knowledge for rural students but a higher prevalence of water saving behaviours among urban, could have been driven by the higher water prices in the city or by the fact that this rural areas are rainy. The balanced influence of rural and urban residence in different aspects of the environmental literacy is consistent with previous studies that reported a tendency for

better performance in urban residence, supposedly due to their poor environmental conditions that could lead to greater levels of environmental concern, but also variations dependent on the type of environmental concern tested (Van Liere & Dunlap, 1980). Also, a narrowing in urban/rural differences seems to be in place and over time. rural residents are catching up urban and showing higher environmental concern (Jones et al., 2003). Our results reveal that female students tend to show better knowledge, attitude and behaviours towards the environment, a result consistent with existent literature (Gifford et al., 1982/83; Hines et al. 1986/87; Cordeiro, 2010; Almeida & Azeiteiro, 2011). These results, rather than an outcome of a gender intrinsic/biologic influence, could be a consequence of the specific socio-cultural context that encompasses female condition in our society. In fact, gender, being subject to stereotypes, represents an important component of socio-cultural context with strong influences in the learning outcomes (Igbo et al., 2015). Also, since female students show significantly better marks in Natural Sciences discipline (marks ≥ 4 : 56% for female students against 48.1% for male, $p=0.043$) this tendency to present a better performance in environmental literacy could be an influence of the curriculum itself as also of the SES, despite we didn't found signs of a higher SES through a significantly higher car use (e.g. using parents as their chauffeurs to go to school: 46.4% for female students against 43.9% for male, in a 'always' and 'very often' basis, $p=0.29$). Despite lacking empirical support, Van Liere and Dunlap (1980) hypothesized that when men have a lower level of environmental concern it could be because of competing interests, meaning that men's higher concern with economic issues comes at the expense of environmental concern. Later, Davidson and Freudenburg's (1996) also attempts to explain gender differences in environmental concern (Davidson & Freudenburg, 1996). Among those with more empirical support, they stated that women are more concerned about the environment when the risks involve issues of health or safety and, since there is a negative association between institutional faith and environmental concern, because they are less trusting of institutional structures. Despite our study does not attempt to explain gender differences, it is interestingly to note that the profound changes that women experienced in their social and economic role along the past decades seems not to have blurred the gender effect in environmental literacy. However, the above explanations for gender differences need to be carefully considered in the analysis of present results, since our subjects were constituted by young people with average age of 15 years, which, obviously, were not yet be fully integrated in their adulthood. Also, accordingly to Price and Bohon (2012), gender shouldn't be considered alone in their association to environmental literacy since male and female could be differently influenced by socio-demographic characteristics. For example, Price and Bohon (2012) found that women more educated increases their concern for the environment in opposition to a decrease found in men. Thus, to better understand gender influence on environmental literacy levels among students from Madeira Island (Portugal), future studies need to be done in which other variables defined by literature should be included and an evaluation between gender and socio-demographic characteristics should be considered. Also, the important role that gender plays in environmental literacy outcomes should be taken in consideration on environmental education projects and campaigns. The higher commitment with the environment, especially through their behaviours, found in present and previous studies among female students suggest that environmental education should use this empathy to bring male students closer to the environmental concerns, namely through groups that include both genders and are committed to solve specific environmental problems (Stevenson et. al., 2013).

On concordance with previous studies (Brody & Storksdieck, 2013), our results show that the participation on school's environmental activities is also an important predictor for higher levels of environmental literacy, especially for environmental knowledge and

concordance with the New Ecological Paradigm but with no relevant effect on environmentally responsible behaviours. Since only 20.6% of the 9th grade students from Madeira Island assume to have participated in school's environmental activities in the past few years, and considering its importance for environmental education performance, a higher dynamism is needed in order to integrate the school community in most practical activities. Unfortunately, stocked between walls, children have been increasingly sidelined from a nature contact and interaction, a reality with concerning effects on their physical and mental health (Louv, 2005). Besides that, the loss of contact with the outside environment also weakens the physical and emotional connections with the natural world, which leads to a lower willingness to actively participate in its protection (Louv, 2005).

When, considering previous (Author, in press) and present results, consistent environmental education projects, such as EcoSchools, are less determinant in the development of environmental literacy than the socioeconomic context in which students are entered, it is clear that the effectiveness in environmental education implies a partnership with the surrounding community and a higher fluidity well beyond the limits imposed by the school walls. Thus, socio-demographic variables need to be centred in the environmental education process, especially understanding it as the reflex of an environmental, economic and sociocultural context in which learning outcomes are maximized. In fact, Lucas (1979) considers that the context to develop environmental literacy needs to be the environment itself in which students could be involved in the implementation of environmental protection measures. In other words, environmental education should be based in learning with the environment and to the environment. Other authors agree with this and argues that students should had the opportunity to solve, actively and democratically, local environmental problems as a way to understand the relationship with their lives as well to feel motivated by the success of their one actions (Uzzell et al., 1995). So, the environmental literacy, cultivated by the environmental education, found a fertile ground in the context of Vygotsky's (1978) socio-cultural theory of human learning. In fact, also in environmental literacy, learning occurs through the interaction with the social environment and, to be effective, needs real learning contexts. For that reason, environmental literacy tends to be higher when a direct contact with nature is promoted as well when the interaction with the environment and its problems is mediated by an adult role model (Brody & Storksdieck, 2013). Therefore, the predictors for environmental literacy evaluated on present study, as also many others, could mirror the effects of this framework.

Conclusions

Evaluating environmental literacy and identifying their predictors in different populations is an important contribution to better understand the pathway through which environmental education could be more effective. Besides the determinant influence of SES, present study identified two strong environmental literacy predictors among 9th grade Madeira Island students: rural or urban residence and higher marks in 8th grade Natural Sciences discipline; and two weaker: female and participation in school's environmental activities. Environmental education programs and strategies in Madeira Island (Portugal), as well as elsewhere, need to consider the fact that students and schools economic and socio-cultural contexts exert an important influence on environmental literacy achievements and, that way, a better integration with local community is needed. In fact, predictors included in present study, and commonly used on several others, seem to be pools of economic and socio-cultural contexts that strongly influence environmental literacy. However, new evaluations and studies need to be done with Madeira Island students not only to include different age groups but also to better understand the effects of the social and environmental contexts in the

development of the environmental literacy and, especially, to evaluate the specific influence of SES. Also, gender association with environmental literacy needs to be refined and linked to socio-demographic characteristics in order to better understand its relationship with socio-cultural contexts. Present and future enlightenments will be helpful to design most effective environmental education programs and strategies suited not only for Madeira Island but also for any other specific context.

Acknowledgements

We thank the boards of the five elementary schools from Madeira Island that have authorized and cooperated with the present study, as also all the 9th grade teachers that applied the questionnaire in their classrooms.

Biographical statement

Hélder SPÍNOLA is currently an assistant professor in the University of Madeira (Portugal) and also a researcher of the Research and Development Centre in Education on the same institution. He is interested in the field of environmental education, especially the influence of societal and environmental factors on the development of environmental literacy. **E-mail: hspinola@uma.pt**

▪ ▪ ▪

References

- Almeida, F. & Azeiteiro, U. (2011). Literacia Ambiental no Ensino Secundário - O caso da Escola Secundária Dr. Manuel Candeias Gonçalves. *Captar- ciência e ambiente para todos*, 3(2): 25-68.
- Bamberg, S., & Schmidt, S. (2003). Incentives, morality or habit? Predicting students' car use for university routes with the models of Ajzen, Schwartz and Triandis. *Environment and Behavior*, 35, 264-285.
- Blumstein, D.T. & Saylan, C. (2007) The failure of environmental education (and how we can fix it). *PLoS Biol* 5: e120 doi:10.1371/journal.pbio.0050120.
- Bogner, F.X., & Wiseman, M. (1997). Environmental perception of urban and rural pupils. *Journal of Environmental Psychology*, 17, 111-122.
- Brody, M. & Storksdieck, M. (2013). Evaluation and Analysis of Environmental Education Programs, Materials, and Technologies and the Assessment of Learners and Learning. In: Justin Dillon, Michael Brody, Robert B. Stevenson (eds.). *International Handbook of Research on Environmental Education* (pp 283-288) New York: Routledge Publishers.
- Câmara, R. (2014). Literacia ambiental da comunidade docente da Escola Básica e Secundária de Santa Maria. *Dissertação de Mestrado*. Universidade Aberta. Porto. 2014. 73 p. Accessed in 19-07-2015 at <http://hdl.handle.net/10400.2/3270>.
- Coleman, J. S. (1966). Equality of educational opportunity (Report No. OE-3800). Washington, DC: National Center for Educational Statistics.
- Cordeiro F (2010). Literacia Ambiental à Saída do Ensino Secundário. *Dissertação de Mestrado*. Universidade Aberta, Lisboa, 128 p.
- Davidson, D. J., & Freudenburg, W. R. (1996). Gender and environmental risk concerns: A review and analysis of available research. *Environment and Behavior* 28(3): 302-339.
- Disinger, J.F. & Roth, C.E. (1992). Environmental Education research news. *The Environmentalist*, 12: 165-168.
- Dunlap, R.E., Van Liere, K.D., Mertig, A.G. & Jones, R.E. (2000). Measuring Endorsement of the New Ecological Paradigm: A Revised NEP Scale. *Journal of Social Issues*, 56 (3): 425-442.

- Erdoğan, M. (2009). Fifth grade students' environmental literacy and the factors affecting students' environmentally responsible behaviors. Unpublished doctoral dissertation, Middle East Technical University, Turkey.
- Freitas, A. (2007). Desenvolvimento e Mudança Paradigmática na Madeira: Atitudes Sociais Sobre Ambiente. *Sociologia, Problemas e Práticas*, 54: 101-125.
- Gifford, R., Hay, R., & Boris, K. (1982/83). Individual differences in environmental attitudes. *The Journal of Environmental Education*, 14(2), 19-23.
- Hamilton, L.C. (2008). Who cares about polar regions? Results from a survey of U.S. public opinion. *Arctic, Antarctic, and Alpine Research*, 40(4), 671-678.
- Hines, J., Hungerford, H., & Tomera, A. (1986/87). Analysis and synthesis of research on responsible environmental behavior: A meta-analysis. *The Journal of Environmental Education*, 18(2), 1-8.
- Hollweg, K. S., Taylor, J. R., Bybee, R. W., Marcinkowski, T. J., McBeth, W. C., & Zoido, P. (2011). Developing a framework for assessing environmental literacy. Washington, DC: North American Association for Environmental Education.
- Hsu, S. (1997). An assessment of environmental literacy and analysis of predictors of responsible environmental behavior held by secondary teachers in Hualien county of Taiwan. (Doctoral dissertation, The Ohio State University, 1997). *Dissertations Abstracts International*, 58(5), 1646A. (UMI nº DA9731641).
- Hunecke, M., Blobaum, A., Matthies, E., & Hoyer, R. (2001). Responsibility and environment: ecological norm orientation and external factors in the domain of travel mode choice behavior. *Environment and Behavior*, 33, 830-852.
- Hungerford, H.R. & Volk, T. (1990). Changing learner behavior through environmental education. *The Journal of Environmental Education*, 21 (3): 8-22.
- Igbo, J.N., Onu, V.C. & Obiyo, N.O. (2015). Impact of Gender Stereotype on Secondary School Students' Self-Concept and Academic Achievement. *SAGE Open*, 5 (1): 1-10. DOI: 10.1177/2158244015573934.
- Jones, R. E., Fly, J. M., Talley, J., & Cordell, H. K. (2003) Green migration into rural America: The new frontier of environmentalism. *Society & Natural Resources*, 16(3), 221-228.
- Kellert, S.R. (1985). Attitudes toward animals; age-related development among children. *The Journal of Environmental Education*, 16(3), 29-39.
- Keene M. & Blumstein D.T. (2010) Environmental education: a time of change, a time for change. *Evaluation and program planning*, 33: 201-204 doi:10.1016/j.evalprogplan.2009.07.014.
- Kostova, Z., Vladimirova, E. & Radoynovska, B. (2011). The environmental concern of nine-grade students from a secondary professional school. *Bulgarian Journal of Science and Education Policy (B JSEP)*, 5 (1): 178-218.
- Krnel D. & Naglič, S. (2009). Environmental literacy comparison between eco-schools and ordinary schools in Slovenia. *Science Education International*, 20 (1/2): 5-24.
- Kollmuss, A. & Agyeman, J. (2002). Mind the Gap: Why do people act environmentally and what are the barriers to pro-environmental behavior?, *Environmental Education Research*, 8:3, 239-260.
- Kuhlemeier, H., Bergh, H. & Lagerweij, N. (1999). Environmental Knowledge, Attitudes, and Behavior in Dutch Secondary Education. *The Journal of Environmental Education*, 30 (2): 4-14.
- Lieberman, G.A. & Hoody, L.L. (1998). Closing the Achievement Gap: Using the Environment as an Integrating Context for Learning, *State Education and Environment Roundtable*.
- Louv, R. (2005). *Last Child in the Woods: Saving Our Children From Nature Deficit Disorder*. Chapel Hill, NC: Algonquin Books.

- Lucas, A. M. (1979). *Environment and environmental education: Conceptual issues and curriculum implications*. Melbourne, VIC: Australian International Press and Publications.
- Lyons, E. & Breakwell, G.M. (1994). Factor predicting environmental concern and indifference in 13- to 16-years-old. *Environment and Behavior*, 26(2), 223-238.
- Maslow, A. (1970). *Motivation and personality* (2nd Ed.). New York: Viking Press.
- McBeth, W. & Volk, T.L. (2010). The national environmental literacy project: A baseline study of middle grade students in United States. *The Journal of Environmental Education*, 41(1): 55-67.
- Nederhof, A.J. (1985). Methods of coping with social desirability bias: a review. *European Journal of Social Psychology*, 15: 263-280.
- Palmer, J.A. (1999) Research Matters: a call for the application of empirical evidence to the task of improving the quality and impact of environmental education. *Camb J Educ* 29: 379-395. doi: 10.1080/0305764990290308
- Pedro, A. (2009). *Monitorização da Literacia Ambiental nos Alunos Finalistas do Ensino Secundário*. Dissertação de Mestrado. Departamento de Zoologia - Antropologia, Faculdade de Ciências, Universidade do Porto, Porto, 152 p.
- Price, C.E. & Bohon, S. A. (2012). Gender Intersections and Environmental Concern. *CSSJ Working Papers #12-01*. http://trace.tennessee.edu/utk_cssjpapers/1
- Shin, D., Chu, H., Lee, E., Ko, H., Lee, M., Kang, K., Min, B., & Park, J. (2005). An assessment of Korean students' environmental literacy. *Journal of Korean Earth Science Society*, 26(4), 358-364.
- Shoukry, S.H., Saad, S.G., Eltemsahi, A.M., & Abolfotouh, M.A. (2012). Awareness, Attitude, and Concerns of Workers and Stakeholders of an Environmental Organization Toward the Environment. *SAGE Open*, October-December 2012: 1-10.
- Author. (in press).
- Author. (2014).
- Stevenson, K.T., Peterson, M.N., Bondell, H.D., Mertig, A.G. & Moore, S.E. (2013). Environmental, Institutional, and Demographic Predictors of Environmental Literacy among Middle School Children. *PLoS ONE* 8(3): e59519. doi:10.1371/journal.pone.0059519.
- Taylor, N., Littledyke, M., Eames, C., & Coll, R.K. (2009). *Environmental Education in Context: An Overview and Some Observations*. In: Taylor, N., Littledyke, M., Eames, C., & Coll, R.K. (Eds.). *Environmental Education in Context- An International Perspective on the Development of Environmental Education*. Rotterdam: Sense Publishers.
- Tikka, P.M., Kuitunen, M.T., & Tynys, S.M. (2000). Effects of educational background on students' attitudes, activity levels and knowledge concerning the environment. *The Journal of Environmental Education*, 31(3), 12-19.
- Tracana, R.B., Ferreira, E. e Carvalho, G. (2012). Environmental Education in Portuguese School Programmes and Textbooks in Two Periods: 1991-2000 and 2001-2006. *The Online Journal Of New Horizons In Education*, Vol. 2, Issue 1: 57-67.
- Trobe, H.L. & Acott, T.G. (2000). A Modified NEP/DSP Environmental Attitudes Scale. *The Journal of Environmental Education*, 32 (1): 12-20.
- Uzzell, D., Rutland, A., & Whistance, D. (1995). Questioning values in environmental education. In Guerrier, Y., Alexander, N., Chase, J., & O'Brien, M. (Eds.), *Values and environment: A social science perspective* (pp. 171-182). Chichester, UK: John Wiley & Sons.
- Van Liere, K. D. & Dunlap, R. E. (1980). The social bases of environmental concern: A review of hypotheses, explanations and empirical evidence. *Public Opinion Quarterly* 44: 181-197.

- Vygotsky, L.S. (1978). *Mind in society: the development of higher psychological processes*. Cambridge, MA: Harvard University Press.
- Wilke, R. (Ed.). (1995). *Environmental Education Literacy/Needs Assessment Project: Assessing environmental literacy of students and environmental education needs of teachers. Final report for 1993-1995* (pp. 5-6). Stevens Point, WI: University of Wisconsin-Stevens Point.

Madeira Adası (Portekiz)'nda Çevre Okuryazarlığı: Demografik Değişkenlerin Etkisi

Hélder SPÍNOLA

University of Madeira, Funchal, PORTUGAL

Özet

Demografik faktörler çevre okuryazarlığını ve özellikle çevreye karşı davranışları doğrudan ve çeşitli değişkenlerle dolaylı olarak etkilemektedir. Bu çalışma Madeira Adası (Portekiz)'nden 9. Sınıf öğrencilerinin çevre okuryazarlıkları üzerine bir dizi demografik değişkenin yordamasını ölçmektedir. 491 öğrencinin cinsiyet, yaşadığı yer (kırsal ve şehir), 8. Sınıf Doğa Bilimleri dersi başarıları, okuldaki çevre etkinliklerine katılımları ve dolaylı olarak sosyo-ekonomik düzeylerinin çevre okuryazarlığı ve özellikle üç temel boyut: Bilgi, tutum ve davranış üzerine etkisi ölçülmüştür. Sonuçlar çevre okuryazarlığının üç temel (yaşadığı yer, 8. Sınıf doğa bilimleri dersi başarı düzeyinin yüksekliği ve yüksek sosyo-ekonomik düzey); iki tane de zayıf (kızlar ve okuldaki çevre etkinliklerine katılım) yordayıcı olduğunu göstermektedir. Araştırmanın bulguları, önceki araştırmalar gibi çevre eğitimi etkinliklerinde sosyo-demografik faktörlerin merkezde bulundurulması ihtiyacını göstermektedir. Demografik değişkenleri çevresel, ekonomik ve sosyo-kültürel içeriği yansıtması açısından çalışmanın bulguları çevre okuryazarlığının Vygotsky'nin gerçek öğrenme içeriklerinin öğrenmede temel rol oynadığını savunan sosyo-kültürel teorisi ışığında desteklediği belirlenmiştir. Ayrıca çevre okuryazarlığı sosyal çevreyle etkileşim ve etkili gerçek öğrenme içeriklerine ihtiyaç duymaktadır. Demografik değişkenlerin Madeira Adası'ndaki öğrencilerin çevre okuryazarlığında sosyo-ekonomik düzeylerle güçlü ilişkisi vardır.

Anahtar Kelimeler: Çevre eğitimi, Çevre okuryazarlığı yordayıcıları, demografik değişkenler, Madeira Adası.

The Effect of Active Learning Based Science Camp Activities on Primary School Students' Opinions Towards Scientific Knowledge and Scientific Process Skills

Meryem Nur AYDEDE YALÇIN*
Nigde University, Nigde, TURKEY

To cite this article: Aydede-Yalçın, M., N. (2016). The effect of active learning based science camp activities on primary school students' opinions towards scientific knowledge and scientific process skills. *International Electronic Journal of Environmental Education*, 6(2), 108-125.

Abstract

It is important for people to be able to judge the nature while actually living in it to gain the scientific perspective which is an important skill nowadays. Within this importance, the general purpose of this study is to examine the effect of active learning based science camp activities on sixth, seventh and eighth grade students' opinions towards scientific knowledge and scientific process skills. In order to achieve this goal, the natural, historical, archeological and the cultural sources of the Cappadocia area were used as a teaching tool. One group quasi-experimental design with pretest and posttest was used in the study. 17 boarding primary school students participated to research. Opinion survey on scientific knowledge, scientific process skills scale, conceptual comprehension survey on environmental problems and observation form were used as a data collection tools. Descriptive and Man Whitney-U analysis techniques were used during assessment of the data. As a result of the study, significant difference was found supporting the students' post-test results of scientific knowledge survey, the number of students' post-application explanations were more than students' pre-application explanations of conceptual knowledge survey on environmental problems.

Key words: Environmental education, active learning, science camp, scientific knowledge, scientific process skills.

Introduction

In recent years, awareness toward environmental education and sustainable development issues has increased both in public institutions and public opinion (Binbaşaran & Tüysüzoğlu, 2005). Many environmental organizations strive for creating public awareness about current negative impacts of ecological disasters on human life and the disasters that would occur in the future (Harting, Kaiser & Bowler, 2001). Free courses, programs, camping trainings that are becoming widespread by the efforts of these organizations, are important developments in raising environmental awareness of families, children and other participants. The number of these organizations giving only informal education is increasing with each passing day (Meydan, Bozyiğit & Karakurt, 2012). Although the trainings on environmental education and sustainable development are important for all groups, there are studies that show the trainings given especially to the children are more important. For instance, when formal education curriculums of different courses used in primary education schools in Turkey are examined, it can be seen that environmental education is included in these curriculums (Altın & Oruç, 2008). As achievements towards nature education have a multidisciplinary content and include

topics concerning both physical sciences and social sciences curriculums in Turkey, they are included in units of Life Sciences, Social Studies and Physical Sciences courses (Köşker, 2013; Erentay & Erdoğan, 2009).

In addition to the importance of starting the environmental education with the children, the content of the education is also essential. It was concluded in the research conducted by Palmer, Suggate, Robottom & Hart (1999) that environmental education experiences gained in childhood period affects perspectives of individuals towards nature on future ages. Also, Zelezny (2010) found in his meta-analysis study, activities done in the classrooms with young participants (under 18 years old) can be more effective to develop environmental behaviors. In addition, Hinds & Sparks (2008) stated that people having nature experience earlier would have more positive affective characteristics towards nature when compared to those having less nature experience. Therefore, it will be the best step to begin nature education with children in terms of recognizing, protecting nature and creating awareness (Köşker, 2013; Chawla & Cushing, 2007).

In order to understand multiple structure of environmental problems, Ozdemir (2007) suggests that it is important to include processes that would enable students to comprehend facts and processes with an “interdisciplinary enlightenment”. Therefore, teaching methods and techniques that will be included in learning-teaching processes is another important factor like beginning environmental education in early ages. While choosing the methods that will be followed in environmental education, learning should be associated with real life, individual requirements should be met and students should be motivated first of all. A teaching process, as it is put forward by Bonwel and Eison (1991), on which is thought and researched, should be put into practice with mastered teaching techniques (Bonwel & Eison, 1991).

When this approach defined by Bonwel and Eison (1991), who are leading names of active learning, is adapted to environmental education, environmental education processes should be arranged according to “research and discovery” teaching strategy and learning processes that would enable students’ active participation should be focused on. Because in active learning, students are educated as individuals knowing about the usage of learnings in real life and aware of real cases instead of acquiring knowledge about irrelevant facts (Seeler, Turnwald & Bull, 1994). Therefore, students are enabled to take active role in using and applying the knowledge about environmental education (Dufresne et al., 1996).

Harting Kaiser and Bowler (2001) concluded that ecological behavior is related to constructive environmental experiences as a result of study they carried out with university students. Similarly, as a result of study carried out by Hartig, Kaiser and Bowling (2001) it is clear that ecological behavior can be gained with students’ constructive experiences. Also Duerden and Witt (2010) stated that environmentalist behavior is consisted with effects of individuals’ knowledge and attitudes towards environment and they also claimed that changes in attitude and knowledge can be gained with behavior that is concretely put into practice.

Active Learning Based Environmental Education

Active learning includes all the activities that students do and think about what is done. In active learning students not only learn about topic or course subject but also they apply the concept they have learned, search about and apply relationship between facts and compare the cases that contradict with their pre-learnings. Owing to these activities students construct their own knowledge instead of the knowledge that teacher transmitted (Chickering & Gamson, 1987; Mattson, 2005). Proposing alternative active learning activities to students instead of traditional methods will give them an opportunity

to discover different learning styles (Cook & Hazelwood, 2002). Students will be able to achieve faster and more permanent learning by the activities in which many senses are used in the application and observation environment that active learning based environmental education activities provided (Erdoğan, 2011). Therefore, by the active learning based environmental education, individuals will not only acquire high level thinking skills towards environmental education topics but also apply this point of view that they developed to cases in which they face in daily life (Özdemir, 2007). It is ascertained that activities done in natural area provide a renewal and an increase in mental attention level, a decrease in stress level and also they create relaxation, curiosity and sense of exploration besides those skills (Elliott & Davis, 2008).

As a result, it necessary to include learning experiences that would give students opportunity to recognize living and non-living creatures, comprehend the relationality and integrity in the nature by directly interacting students with the nature (Özdemir, 2010). When considered from this point of view, students make relations taking physical characteristics of the place they are situated in consideration and learn the region, which they live in, in biochemical, cultural and social aspects by relating the past, present and future of the region. Students develop an awareness of responsibility towards their environment by seeing and noticing the important key relations in this learning and teaching process (Szczepanski, 2006).

Nature education in non-traditional settings that are main focus of this study have come into prominence in Turkey in recent years and have become a popular topic chosen as a research subject in education studies (Erdoğan, 2011). Nature education projects in non-traditional settings are based on the basis of teaching natural and cultural values that protected areas and the around offer to us, with a participative education that is with the contributions of instructors and other professionals (Meydan, Bozyiğit & Karakurt, 2012).

Nature education activities towards youth and young learners in Turkey accelerated with TÜBİTAK's (The Scientific and Technological Research Council of Turkey) application of environmental education program in national parks in 1999 (Ozuner, 2004). These programs that were started with the aim of exploring the language of nature in the national parks by ecology founded nature education programs, in which teachers, graduate and postgraduate students were included at first, have been planned and applied for teacher candidates and primary education students in recent years (see: www.tubitak.gov.tr). These programs for primary education students (especially 4-8 grades) are planned within nature educations and science camps. Moreover, in addition to Ministry of National Education and Ministry of Environment and Forestry which are in the opinion that nature and environmental education should be given in early ages, some non-governmental organizations also carry out projects and works for preschoolers, primary school students and high-schoolers (Erdoğan, 2011). Especially nature protection areas offer important opportunities in activities towards nature education besides the vital importance they have in terms of nature protection works. As a result, regions with nature protection areas are usually preferred for nature education projects (Oğurlu, Alkan & Gündoğdu, 2010).

In recent studies carried out, the most effective environmental education programs' characteristics are defined as being long-termed, giving opportunity to apply and the level of reaching target aims (Chawla & Cushing, 2007) and are also compared as success, deficiencies, content of application and the ways of application in general (Collado, José & Corraliza, 2013).

The courses in the Turkish education system have the purposes to improve the students' scientific perspectives. Therefore, in this study students are expected to understand the language of nature and evaluate the running of nature scientifically by active learning

based activities. The National Science Education Standards (NSES), which is one of the most important studies in science education, stated that teaching strategies aiming all children to grow up as a science literate were required to be used at schools (McCain, 2005). When primary science teaching program in Turkey are examined in terms of its general objective, it is seen that the program emphasis on requirement of growing all the individuals in the society as a science literate, similar to NSES. Science literacy is described as knowing the nature of sciences, understanding how the knowledge is obtained, accepting that the knowledge in sciences is related to known facts and can change as evidences gathered, comprehending main concepts, theory and hypothesis in sciences, perceiving the difference between scientific proof and personal opinion (MEB, 2005). This is the thing meant by scientific perspective in the present study.

Relationship between camp activities and students' opinions towards scientific knowledge and scientific process skills

Students' developing observation skill is important for them to recognize the difference between lifelong learning skills, scientific knowledge and personal opinion; in other words, the ways that scientific knowledge is obtained and characteristics of scientific knowledge (Gürses, Doğar & Yalçın, 2009). Activities based on examination and observation that were realized during the study were aimed to lead students' constructing building stones of scientific knowledge towards nature and learning scientific thinking. Therefore, by the museum visits and field works done in Göreme-Kapadokya historical national park and Aladağlar national park and also my pet activities, students were enabled to make observation in nature and encouraged to make scientific activities in nature by awakening their sense of curiosity towards nature. Within this aim, students would be encouraged to acquire the knowledge and skill of doing research in the case of recognizing mysterious change in nature, life forms of flowers, leaves, insects and living creatures and also activities of animals around by observing in nature.

Environmental problems that occurred because of destruction of natural sources for centuries reached to an uncontrollable dimension in this day and time. Overutilization of natural sources by human causes unconscious consumption of nature sources and rapid destroy in the balance between nature and life that was longstanding. Therefore, the earth without nature, animal products in supermarket and extemporary drama activities were done in this study. Students would be able to informed about the importance of making individual attempts on protecting environmental values by recognizing the importance of ensuring sustainability by using natural resources properly for sustainability of technological developments and leaving a livable world to next generations.

As it is mentioned by Altuğ (2010), we can handle with environmental problems by increasing the number of nature lover and pure-minded people. So, nature art integration, mountaineering, herbarium activities were included in this project. As a result, people would notice the methods of using nature without harming. Thus people are expected to develop skill of struggling against environmental pollution and factors that harm nature at the present time.

Diversity is one of the main characteristics of a healthy nature. Because creatures in a definite common living space evolve altogether. Each species needs another species to sustain its existence. Extinction of one of the species causes biological downfall, breaking food chain that is vital for system which means the breakdown of ecosystem (Yıldız, Sipahioğlu & Yılmaz, 2000). Thinking about the importance of biological diversity on sustainability of life, ecological environments and human, butterfly collection, insect training sections were included in this study. In this section, students watched various

short documentaries and discussed about the documentaries. Therefore, students could evaluate the relationship of human-nature noticing the importance of nature protection.

Importance of the study

Environmental problems became a current issue of human since the second half of 20th century. The reasons, results and suggestions about these problems have been discussed increasingly (Özey, 2001). As a result, activities on ecology games and creating an eco-city were included in this study. During the activity of creating an eco-city, students with a group work constructed an ecological and modern city on sand pit by using stationery such as cardboard, scissors etc. in this study. In ecological games activity, funny games were played towards ecological problems and solutions to these problems. By means of these activities, students were prevented to remain insensitive or be deaf (ignore) to environmental problems that they face so they were encouraged to state opinion about solution of environmental problems. Besides they would become aware of the importance of local efforts towards these environmental problems and they would also encourage the people around the environment that they live in to develop conscious behaviors towards solving environmental problems

Thus, this study aims to examine the effect of science camp activities on regional primary boarding school students' opinions towards scientific knowledge and scientific process skills Within this main goal, the sub-goals below are searched for answer:

- a) Do the active learning based science camp activities have an impact on primary school students' views on scientific knowledge?
- b) Do the active learning based science camp activities have an impact on primary school students' scientific process skills?
- c) Do the active learning based science camp activities have an impact on primary school students' conceptual knowledge towards environmental problems?

Methodology

Single grouped quasi-experimental design with pretest ant posttest was used in the present study. The semi experimental designs with pretest and posttest with a single group are the studies in which it is not possible to form control groups and this research design forms the research group through some measurements and criteria instead of forming the research group arbitrarily (Bishop-Clark & Dietz-Uhler, 2012). The study was carried within the project called 'Ecology Founded Summer Camp in Cappadocia Region' with the support of TUBITAK..

Implementation of Camp Curriculum

In this study, theoretical parts of environmental activities were realized in Niğde University and field works were done in Cappadocia-Göreme Historical National Park and Aladağlar National Park. Before implementing the real camp study, a pilot camp was conducted and evaluated. As a result of the pilot evaluations, a general camp program for 5 days was prepared under the titles stated above.

In general, the content of the camp was realized under 15 titles. These are (1) drama in nature, (2) nature-art integration, (3) museum visits, (4) pet care, (5) ecology games, (6) ecological environments and human, (7) mountaineering, (8) herbarium, (9) insect training, (10) the world without human, (11) eco-city, (12) animal products in supermarkets, (13) butterfly collection, (14) field work in Aladaglar, (15) field work in

Cappadocia-Goreme historical national park. Active learning based science camp lasted for 5 days and was realized between 18-22 July 2012. 8 trainers were included in the study.

Working Group

Participants chosen as target group within the framework of main objective of the study were regional primary boarding school students at sixth, seventh and eighth grades (11-14 ages) that were studying at various provinces of Turkey. In primary education level in Turkey, students face Physical Sciences and Social Studies courses that mostly include gaining topics on nature.

There are two reasons why the project was carried out with regional primary boarding school students. The first one is that scientific studies towards regional primary boarding schools in which students with limited opportunities study in general are limited. The second reason is to develop activity samples of that developed education program and that kind of science camp works that would be applied to all primary schools when desired.

Primary school level is a compulsory education level that all individuals have to receive. For individuals that will not continue their education, the only way providing them with the knowledge on “nature” will be environmental education that they received in primary education. As it is stated by Gökçe (2004), primary school students are always on the move and inclined to participate actively into activities that will be done for learning purpose. So an education program that will be developed for primary school students should be based on active learning approach that is in accordance with their learning inclination. Therefore, the region should be introduced to students with active learning approach based learning activities by using natural, historical, archeological and cultural sources of Göreme Historical National Park and Aladaglar National Park that are in Cappadocia region as an educational instrument and students should be given opportunity to have a conscious view towards nature discovering the running basis of nature, the processes and relationships in nature by observation. As a result, a study that reaches the aims stated above should be provided for primary school students by using active learning methods and techniques.

Geographical area sampling method, which was usually used in qualitative research, was used while selecting the students that would participate in the project. The reason why this sampling had been chosen was to create a study group enabling maximum diversity in terms of students’ characteristics as target population of the study was wide. According to geographical area sampling method, during the study, the primary school students that volunteered by filling in the application form on the website of Nigde University was grouped according to the seven geographical areas of Turkey. After this study 17 students that applied where selected- by using the project budget in the most efficient way-.

Gathering Data

In the study, students’ cognitive, affective and psychomotor skills were evaluated one by one. Students’ gains in cognitive level were revealed by applying ‘conceptual knowledge survey on environmental problems’, affective domain gains were revealed by applying ‘Scientific Knowledge Survey’ and ‘scientific process skills scale’ and their behaviors towards application were revealed by using ‘observation form’.

The first data collection tool was “Scientific Knowledge Survey”. This data collection tool was applied to evaluate students’ opinions on the nature of scientific knowledge

quantitatively. 'Scientific Knowledge Survey' that was developed by Küçük (2008) included totally 16 items and students were supposed to prefer one the answers changing among I agree, I have no idea, I disagree. The scale was applied twice; the first one was before starting camp activities (the first day of the study) and the second one was after applying summer camp activities (the last day of the study). The survey lasted approximately for 10 minutes.

The second data collection tool was 'Scientific Process Skills Scale'. This data collection tool was used aiming to define the impacts of nature activities on students' scientific and creative thinking skills. With this aim, 'Scientific Process Skills Scale' that was developed by Okey, Wise and Burns (1985) and adapted to Turkish by Geban, Aşkar & Ozkan (1992) was used.

The third data collection tool was 'Conceptual Knowledge Survey on Environmental Problems' which was used in order to define contribution of nature activities to students' knowledge and comprehension. Conceptual Knowledge Survey on Environmental Problems was used before and after the study. The survey was prepared within the framework of main topics that would be mentioned during the study and four-point grading system was applied. Under each topic item, there was given space to enable students to make explanations.

'Observation Form' was used to define students' psychomotor skills towards scientific views on environmental issues in the project. The observation form was filled by two observers observing 4 primary school students in different times. While evaluating data gathered from observation form, point averages of the two observers were used. (All the items in the form are positive and there is a 3 point evaluation scale which means that students were scored as 3, 2, 1 according to cases in which students exhibited the behavior stated in each item).

Analyzing Data

Descriptive and Man Whitney-U analysis techniques, which are used in quantitative and qualitative researches, were applied during assessment of the data collected in the study. In the analyses of qualitative data that would be gathered from 'Scientific Knowledge Survey' and 'Scientific Process Skills Scale', Man Whitney-U analysis techniques were applied. SPSS program was used for this analysis and .05 was accepted as significance level in interpretation of results. Descriptive analysis technique was applied for 'Conceptual Knowledge Survey on Environmental Problems'. While analyzing these forms the data gathered were coded with numbers. For example, the first student was coded as S1 (Student one) and the second students as S2 (Student two). The data coded with numbers were examined by two researchers. And finally, all the answers that students gave were tabularized after calculating frequency values. In the assessment of "Observation Form" frequency analysis technique was used.

Findings

Findings Obtained from the Analysis of Scientific Knowledge Survey

In this study 'Scientific Knowledge Survey', which was developed by Küçük (2008) was used in order to evaluate students' opinion on scientific knowledge quantitatively. The survey included totally 16 items regarding scientific knowledge. Mann Whitney U- Test analysis technique was used on pretest and posttest results obtained as a result of applications and the results were shown on Table 1.

Table 1.

Mann Whitney U-Test results of primary school students' 'Scientific Knowledge Survey' Pretest and Posttest Results

	N	MeanRank	Rank Sum	U	P
Pretest	17	20.35	488.50	188.5	.038
Posttest	17	28.65	687.50		

When Table 1 is examined, it is seen that mean rank of pretest scores of 'Scientific Knowledge Survey' participating primary school students is 20.35, rank sum is 488.50, mean rank of posttest scores is 28.65 and rank sum is 687.50. When p values ($P = .038 < .05$) are examined, it was seen that there is a significant difference between two groups. As students' posttest mean ranks are higher than pretest mean ranks, it is seen that this difference is in favor of students' posttest scores.

Findings Obtained from the Analysis of Scientific Process Skills Test

Scientific Process Skills Scale, which was developed by Okey, Wise and Burns (1985) and adapted to Turkish by Geban, Aşkar and Ozkan (1992), was used to evaluate students' scientific process skills in the study. During the study, data gathered by the scales' validity reliability studies done by Aktamış (2007) were used as they were more current. In the studies carried out by Aktamış (2007), the version of the scale that constitutes of 26 items and has Cronbach Alpha coefficient .80 was used. The scale was applied to students in the first and the last day of the study. Pretest and posttest results obtained from applications are shown on the Table 2.

Table 2.

Mann Whitney U- test results of pretest and posttest scores towards primary school students' scientific process skills scale

	N	MeanRank	Rank Sum	U	P
Pretest	17	16.65	283	130	.634
Posttest	17	18.35	312		

When Table 2 was examined, it was seen that mean rank of pretest scores of participating students' scientific process skills scale was 16.65, rank sum was 283, mean rank of posttest scores was 18.35, rank sum was 312. When p values ($P = .634 > .05$) were examined, it was seen that there was not a significant difference.

Findings Obtained from the Analysis of Survey on Conceptual Knowledge on Environment Questionnaire

'Conceptual Knowledge on Environment Questionnaire' was used to define contributions of camp program applied on students' knowledge and comprehension. The

questionnaire was used in the study was applied before and after the study to students. Results were presented in Table 3;

Table 3.

Descriptive values regarding survey on conceptual knowledge towards environmental problems

<i>Environmental Problems</i>				<i>Scientific applications towards solution of environmental problems</i>				<i>The methods that people benefited from nature without harming in the past</i>				<i>Threats towards biological diversity of nature</i>																			
Pretest		Posttest		Pretest		Posttest		Pretest		Posttest		Pretest		Posttest																	
I don't know any	I know a little	Average level	I know well	I don't know any	I know a little	Average level	I know well	I don't know any	I know a little	Average level	I know well	I don't know any	I know a little	Average level	I know well																
0	2	15	0	0	1	8	7	3	5	9	0	0	1	10	6	3	5	8	1	1	4	5	7	4	3	7	3	1	3	4	9
-Environmental pollution caused by human	-Global warming	-Climate change	-Air, soil, water pollutions	-Erosion	-Environmental pollution	-Gases of factories	-Undeniable energy sources	-Human throwing garbage around	-Not recycling	-Global warming	-Air, water and soil pollution	-Recycling	-Planting trees	-Not throwing garbage to around and warning people throwing garbage to around	-Carrying out works towards protecting environment as a society	-Using renewable energy sources	-Using public transportation	-Creating awareness	-I learned this issue from historical artifacts	-People less harming nature in the past	-Less technology in the past	-Gases from factories	-People with awareness	-overusing chemicals	- Destroy in places where animals live	- Environmental pollution	- Harm on living creatures	- Global warming	- Extinction of animals and herbs		

Table 3.

Descriptive values regarding survey on conceptual knowledge towards environmental problems (Table continued)

<i>Our responsibilities for protection of nature</i>				<i>Our social responsibilities to protect nature</i>				<i>Management of natural sources</i>				<i>Sustainability of natural sources</i>											
Pretest		Posttest		Pretest		Posttest		Pretest		Posttest		Pretest		Posttest									
don't know any	I know a little	Average level	I know well	don't know any	I know a little	Average level	I know well	don't know any	I know a little	Average level	I know well	don't know any	I know a little	Average level	I know well								
2	4	6	5	0	2	5	10	3	3	6	5	0	0	7	10								
- Not polluting environment - Not using chemicals - Providing recycling				-Protecting environment as a society - Respecting the nature -Creating awareness -Not cutting trees -Not overusing chemicals				-Creating awareness - Doing activities to protect nature				- Not throwing garbage to environment - being a conscious consumer -Separating garbage and recycling - Not cutting trees				- Constructing fish farms on fault lines - Getting electric energy from wind power -Building houses working with solar energy				- We should be economic while using nature sources and not waste them - We should not pollute natural sources - We should protect our sources			

When post-application frequency values and pre-application frequency values of students were compared, it was clearly seen that there was a transition to 'I know it well' option. Besides when students' answers were examined, it was seen that the number of students' post-application explanations were more than students' pre-application explanations. 17 students that could not put forward any idea for the items that 'methods of people using the environment without any harm in the past', 'Management of natural sources' and 'Sustainability of natural sources' during the pretest application, could get an idea about the items at the end of the study.

Data Gathered from Observation Form

One of the data collection tools, which were used to define contribution of the project to students' psychomotor skills in reaching scientific knowledge, is 'Observation Form'. The observation form attached was filled by two observers observing 4 primary school students in different times. Descriptive values gathered are shown on the table below.

Table 5.

Descriptive values regarding primary school students' observation form

	1. Student	2. Student	3. Student	4. Student
1. Listened to suggestions and telling of his/her friends	3	2	2	3
2. Did the activity as trainer or our guide suggested	2,5	3	2	3
3. Encouraged his/her friends without hurting them	1	2	1	1
4. Not disturbed by the help that his/her friends offered	2	2	2	2
5. Did his/her best for success of the activity	2,5	2	1	2,5
6. Could accomplish his/her duty	2	2	1	2
7. Asked questions when he/she could not understand	2	1	1	1
8. Supported his/her group friends in their studies	2	2,5	1	2,5
9. Used the time in an efficient way during studies	1	2	2	1

As a result of the analysis of data gathered from primary school students, the lowest scores that students got among items were 'Encouraged his/her friends without hurting them' and 'Asked questions when he/she could not understand'. The item that students got the highest score was 'Listened to suggestions and telling of his/her friends'.

Discussion and Conclusion

The environment that individual is in should turn into an environment that s/he lives in and aware of rather than being something that is required to learn and nature education should be arranged to give them that opportunity (Köşker, 2013). When scientific researchers are examined, it is strongly emphasized that there is a close relationship between environmental perspectives of children and instructive experiences gained in

nature (Özdemir, 2010). Therefore, the main objective of this study is to enable primary school students at sixth, seventh and eighth grades to evaluate the environment that they live in with scientific views by using natural, historical, archeological and cultural sources of Cappadocia region as a teaching tool with active learning based activities. The first research question put to reach this general objective was that 'Do the active learning based science camp activities have an impact on primary school students' views on scientific knowledge? As a result of Man Whitney U analysis carried out regarding this sub-problem, a significant difference ($p=.038$) in favor of students' posttest scores was found. So it is concluded that active learning based science camp activities had an impact on students' views towards scientific knowledge. There are some studies in accordance with findings of this study. For example, in the research that was carried out by Köseoğlu et al. (2011) it was concluded that ecology founded nature education study done for primary school students started students' academic thinking. Şahin-Pekmez and et al. (2010) concluded that out of class science studies developed students' comprehension of the nature of science. Metin and Leblebicioğlu (2011) also concluded that students developed more scientific views towards science concepts by science camp that was realized with out of class activities.

Individuals are supposed to be good observers to notice environmental problems. Observation skill is just one of the stages of scientific process skills. Therefore, students are required to make a plan in accordance with the conditions of problem that they observed and to apply this plan successfully in order to realize scientific solution that they developed, in practice level (with concrete experiences) to contribute solution of environmental problems. As a result, individuals that acquired scientific process skills can find more effective solutions to environmental problems. For this reason, the second sub-problem of the study was 'Do the active learning based science camp activities have an impact on primary school students' scientific process skills? When Man Whitney U test results, which were applied on scale used to solve this sub problem, are examined, there could not be found a significant difference between pretest and posttest scores of students. The results of the study carried out by Feyzioğlu and et al. (2012) differentiate to results of this study. As a result of interviews made during qualitative study in which the impacts of activities done learning by doing on development of students' scientific process skills, it was concluded that many students were in the opinion that their scientific process skills had improved.

During this study, the reason why they did not occur a significant difference between primary education students' pretest and posttest scores could be that study duration was not long enough to create a significant difference in students' scientific process skills.

The third sub-problem of the study was that 'Do the active learning based science camp activities have an impact on primary school students' conceptual knowledge towards environmental problems?' As a result of qualitative analyses carried out to reply that sub-problem, it was clearly seen that students transmitted to 'I know well' option when students' post-application and pre-application frequency values were compared. In conclusion it could be deduced that an ecological education given with active learning based activities had an effective impact on students' conceptual knowledge. In the study that was carried out by Manzanal, Barreiro and Jiménez (1999), it was concluded that fieldwork studies enabled students to explain ecological concepts. The results of the study carried out by Erdoğan (2011) has some similar results with this study. Erdoğan (2011) searched 4th through 8th grade students' environmental knowledge, affect, skills and behavior as the main components of environmental literacy. As a result of his study, students' environmental knowledge, environmental sensitivity, intention, environmental attitudes and responsible environmental behaviors significantly increased.

Based on both applied observation results, it was deduced that active learning based science camp activities had improved students' psychomotor skills towards scientific

views on environmental issues. In the study carried out by Bexell, Jarrett and Xu (2013) it was concluded that camp program had increased students' sense of empathy and also attention and knowledge for getting into action in nature. So, that result is similar to result of this study. In the study carried out by Collado, Staats and Corraliza (2013) it was inferred that staying at camp had increased students' willingness to exhibit ecological behaviors and also their beliefs and feelings towards nature. In the study carried out by Laaksoharjua, Rappea, Kaivolab (2012), it was found out that the gardening studies are good hands on environmental education activities and that the primary school children could develop effective social skills through these activities. All these results can be the signs that the students can develop upper level learning skills on science through the nature activities.

As a result, it was found out in the present study that the camping activities in nature based on active learning are effective on the scientific knowledge and scientific process skills of students. Everything happening in the nature has a scientific angle. During the camping activities most of which occurred as field trips, the students were able to realize this science in the nature and share them through the camp leaders. They were guided to not to do this exploration randomly but in a suitable way to the nature's essence. Therefore, it was tried to help the students to gain the habit of evaluating nature through a scientific perspective via the skills, experience and the knowledge they had with the camping activities.

Acknowledgements

This study was supported by TUBITAK in 2012 [Project Code: 107B070]. I would like to offer my special thanks to TUBITAK and all trainers participating in the study for their contribution.

References

- Aktamiş, H. (2007). The effects of scientific process skills on scientific creativity: the example of primary school seventh grade physics unit. PhD Thesis. Dokuz Eylül University, İzmir.
- Altın, B. N. & Oruç, S. (2008). Effects of beginning of nature sports in early ages to the environmental education. *Journal of Cukurova Educational Faculty*, 3 (35): 8-10.
- Altuğ, T. (2010). Butterfly wings? Nuclear energy?. *Kelebek Kanadı Mı? Nükleer Enerji Mı?* *Unlimited Education*, 10.
- Ballantyne, R., Fien, J. & Packer, J. (2001). Programme effectiveness in facilitating intergenerational influence in environmental education: lessons from the field. *Journal of Environmental Education*, 32 (4), 8-15.
- Bexell, S. M., Jarret, O. S. & Xu, P. (2013). The effects of a summer camp program in china on children's knowledge, attitudes and behaviors toward animals: a model for conservation education. *Visitor Studies*, 1(16), 59-81.
- Binbaşaran-Tuysuzoglu, B. (2005). Green BOX Project: Environmental education and education for sustainable development in Turkey *Yeşil KUTU Projesi Türkiye'de Çevre Eğitimi ve sürdürülebilir Kalkınma İçin Eğitim ön Araştırma Raporu* Research Report
- Bishop-Clark, C. & Dietz-Uhler, B. (2012). Engaging in the scholarship of teaching and learning: A guide to the process, and how to develop a project from start to finish. Sterling, Va.: Stylus Pub.
- Bonwell, C. & Eison, J.A. (2006). Active learning: creating excitement in the classroom. George Washington University. Higher Education Report No.:1 Retrieved on

- March 2006 from
www.eric.ed.gov/ERICDocs/data/ericdocs2/contentstoragee01/0000000b/80/2a/15/f8.pdf
- Celep, A. & Bacanak, A. (2013). Yüksek lisans yapan öğretmenlerin bilimsel süreç becerileri ve kazandırılması hakkındaki görüşleri. *Türk Fen Eğitimi Dergisi*, 10 (1), 56-78
- Chawla, L. & Cushing, D. F. (2007). Education for strategic behavior. *Environmental Education Research*, 13 (4), 427-452
- Chickering, A. & Gamson, Z. F. 2009. seven principles for good practice. *AAHE Bulletin* 39: 3 (1987) <http://www.unm.edu/~oset/UsingActiveLearning.html> in 22 Feb. 2009
- Cinar, D., Dogu, S. & Meydan, A. (2008). Pre-service primary school teachers' attitudes towards to environment. Paper presented at the VII. National Primary School Education Symposium, Turkey. 2008
- Collado, S., Staats, H. & Corraliza, J. A. (2013). Experiencing nature in children's summer camps: affective, cognitive and behavioral consequences. *Journal of Environmental Psychology*, 33, 37-44
- Cook, E. D. & Hazelwood, A. C. (2002). An active learning strategy for the classroom "who wants to win...same mini chips ahoy? *Journal of Account Education*, 20, 297-306
- Dresner, M. & Gill, M. (1994). Environmental education at summer nature camp. *Journal of Environmental Education*, 25(3), 35-41
- Duerden, M. D. & Witt, P. A. (2010). The impact of direct and indirect experiences on the development of environmental knowledge, attitudes and behavior. *Journal of Environmental Psychology*, 30(4), 379-392
- Dufresne, R.J., Gerace, W. J., Leonardo, W. J., Mestre, J. P. & Wenk, L. (1996). Classtalk: A classroom communication system for active learning. *Journal of Computing in Higher Education*, 7, 3-47
- Elliot, S. & Davi,s J. (2008). Why natural outdoor play spaces?. In S. Elliot (Ed). *The Outdoor Play Space Naturally For Children Birth to Five Years* (P.1-13). New South Wales: Pademelon
- Erdoğan, M. (2011). The effects of ecology-based summer nature education program on primary school students' environmental knowledge, environmental affect and responsible environmental behavior. *Educational Sciences: Theory and Practice*, 11(4), 2223-2237
- Erdoğan, M. (2015). The effect of summer environmental education program (seep) on elementary school students' environmental literacy. *International Journal of Environmental & Science Education*, 10(2), 165-181
- Erentay, N. & Erdogan M. (2009). Nature education in 22 steps 2 Adımda Doğa Eğitimi, ODTU Publication, Ankara
- Feyzioglu, B., Ozenoglu-Kiremit, H., Samur-Ozturk, A. & Aladag, E. (2012). Yıbo's are thinking scientifically in natural environment. *Journal of Research in Education and Teaching*, 1(4), 65-74
- Geban, O., Aşkar, P. & Ozkan, I. (1992). Effects of computer simulated experiments and problem solving approaches on students learning outcomes at the high school level *Journal of Education Research*, 86(1), 5-10.
- Gokçe, E. (2004). Students' and teachers' opinions regarding active learning process in elementary education köğretimde Aktif Öğrenme Sürecine İlişkin Öğrenci Ve Öğretmen Görüşleri, Akdeniz University, *Journal of Faculty of Education*, 1,53.
- Gürses, A., Dogar, Ç. & Yalçın, M. (2005). The nature of science and higher education students ideas about the nature of science" Bilimin doğası ve yüksek öğrenim öğrencilerinin bilimin doğasına dair düşünceleri, *Journal of National Education*, 166.
-

- Hartig, T., Kaiser, F. G. & Bowler, P. A. (2001). Psychological restoration in nature as a positive motivation for ecological behavior. *Environment and behavior*, 33, 590-607
- Hinds, J. & Spark, P. (2008). Engaging with the natural environment: the role of affective connection and identity. *Journal of Environmental Psychology*, 28, 109-120
- Keles, O., Uzun, N. & Varnaci-Uzun, F. (2010). The change of teacher candidate' environmental consciousness, attitude, thought and behaviors with nature training project and the assessment of its permanence. *Electronic Journal of Social Sciences*, 9(32), 384-401.
- Keating, M. (1993). *The Earth summit's agenda for change : a plain language version of agenda 21 and the other Rio agreements*. Ankara: UNEP Turkey committee publications
- Küçük, M. (2006). *Study Toward Teaching the Nature of Science For Seventh Grade Primary Students*. PhD Thesis. Karadeniz Teknik University, Trabzon.
- Kosoglu, M., Ozdemir, A., Baysan, S., Akar-Vural, R., Inci, E., Evci-Kiraz, D., Gençsoylu, I., Boz, O., Hazir, C. & Ertugrul, E. (2011). Ecology based environmental education at Çine beekeeping museum. *Journal of Anatolian Natural Sciences*, 2(2), 24-33
- Kossak, A. & Bogner, F.X. (2012). How does a one-day environmental education programme support individual connectedness with the nature? *Journal of Biological Education*, 46(3), 180- 187
- Köşker, N. (2013). Elementary school students' and prospective elementary school teachers' perceptions of nature and thoughts of their responsibilities towards the nature. *International Periodical for the Languages, Literature and History of Turkish or Turkic*, 8(3), 341355
- Manzanal, R. F., Barreiro, L. M. R. & Jimenes, M.C. (1999). Relationship between ecology fieldwork and student attitudes toward environmental protection. *Journal of Research in Science Teaching*, 36(4), 431-453.
- Mattson, K. (2005). Why "active learning" can be perilous to the profession. *Academe* 91(1). 23-26.
- Mccain, J. C. (2005). *Qualitative study of pre-service teachers using co-teaching as a method to understand scientific process skills to teach inquiry*. PhD. Thesis, College of Human Resources and Education, Morgantown, West Virginia.
- MEB (Ministry of Education Milli Eğitim Bakanlığı). *Elementary Science and Technology Courses (sixth, seventh and eighth Grades) Curriculum*. Chairman of the Board of Education of the Ministry of Education, Ankara Retrieved on May, 2007 from www.meb.gov.tr
- Metin, D. & Leblebicioglu, G. (2011). How did a science camp affect children's conceptions of science? *Asia-Pacific Forum on Science Learning and Teaching*, 12 (1). Retrieved February 2, 2014 from www.ied.edu.hk/apfslt/v12_issue1/kilic
- Meydan, A. & Bozyigit, R. & Karakurt, M. (2012). Meet the level of expectation of the participants on Ecology-Based Nature Education Ekoloji Temelli Doğa Eğitimi Projelerinin Katılımcı Beklentilerini Karşılama Düzeyleri Marmara Geographical Review, 25, 238-255.
- Ogurlu, I., Alkan, H. & Gundogdu, E. (2010). *Training project-I At isparta natural protected areas: perceptions and expectations of participations Isparta Korunan Doğal Alanlarında Doğa Eğitimi Projesi -I:Katılımcıların Algı Ve Beklentileri* Paper presented at the III. National Black Sea Forestry Congress. Turkey. May 2010.
- Okey, J. R., Wise K.C. & Burns, J. C. (1985). Development of an integrated process skill test: TIPS II. *Journal of Research in Science Teaching*, 22 (2), 169-177

- Ozaner, F. S. & Yalçın, G. (2000). Scientific environmental education in national parks. Paper presented at the V. International Symposium on Ecology and Environmental Problems. Ankara. December 2000
- Ozdemir, O. (2007). A new environmental education perspective: education for sustainable development. *Education and Science*, 32 (145), 23-39
- Ozdemir, O. (2010). The effects of nature-based environmental education on environmental perception and behavior of primary school students. *Pamukkale University Journal of Education*, 27, 125-138.
- Ozey, R. (2011). Contemporary world issues. Active Publication: Istanbul
- Palmer, J. A., Suggate J., Robottom I. & Hart P. (1999). Significant life experiences and formative influences on the development of adults' environmental awareness in the UK Australia and Canada. *Environmental Education Research*, 5(2) 181-200
- Şahin-Pekmez, E., Yılmaz H. & Kahveci, C. (2010). Influence of learning science in outdoor settings on 5th grade students' understanding of the nature of science. Paper presented at the 7th International Conference on Hands-on Science. Rethymno-Crete. July 2010.
- Seeler, D. C., Turnwald K.H. & Bull K.S. (1994). From teaching to learning. *Journal of Veterinary Medical Educatio*, 21(1), -
- Szczepanski, A. (2007). Outdoor education-authentic in the context of landscape literary education and sensory experience. perspective of where, what, why, how and when of learning environments. *Inter-Disciplinary Context and The Outdoor and Indoor Dilemma*, Retrieved on June 20, 2007 from <http://www.liu.se/esi/cmu/forskning/andersSzczepanski.pdf>
- Yildiz, K., Sipahioglu, Ş. & Yılmaz, M. (2000). Environmental science. Gündüz Training and Publishing: Ankara.
- Zelezny, L. 1999. Educational interventions that improve environmental behaviours: A meta-analysis. *The Journal of Environmental Education*, 31 (1): 5-14

Aktif Öğrenmeye Dayalı Bilim Kampı Etkinliklerinin İlköğretim Öğrencilerinin Bilimsel Bilgiye Yönelik Görüşlerine ve Bilimsel Süreç Becerilerine Etkisi

Meryem Nur AYDEDE YALÇIN

Niğde Üniversitesi, Niğde, Türkiye

Özet

Bireylerin içinde yaşadıkları doğayı anlamaları günümüzün önemli becerilerden biri olan bilimsel bakış açısı kazanmaları için önemlidir. Bu önem doğrultusunda, bu çalışmanın genel amacı, aktif öğrenmeye dayalı bilim kampı etkinliklerinin ilköğretim altıncı, yedinci ve sekizinci sınıf öğrencilerinin bilimsel bilgiye yönelik görüşlerine ve bilimsel süreç becerilerine etkisini araştırmaktır. Bu amacı gerçekleştirmek için, Kapadokya yöresinin doğal, tarihi, arkeolojik ve kültürel kaynakları bir öğretim aracı olarak kullanılmıştır. Çalışmada, öntest-sontest tek gruplu yarı-deneysel desen kullanılmıştır. Çalışmaya 17 ilköğretim yatılı ilköğretim bölge okulu öğrencisi katılmıştır. Çalışmada veri toplama aracı olarak, bilimsel bilgiye yönelik görüş anketi, bilimsel süreç becerileri ölçeği, çevre problemlerine yönelik kavramsal anlama anketi ve gözlem formu kullanılmıştır. Çalışmada elde edilen verilerin analizinde, betimsel analiz ve Man Whitney-U analiz teknikleri kullanılmıştır. Çalışma sonucunda, öğrencilerin bilimsel bilgiye yönelik görüş anketi son-test puan ortalamaları lehine anlamlı farklılık olduğu, çevre problemlerine yönelik kavramsal anlama anketi son uygulama görüş sayılarının, ön uygulama görüş sayılarından fazla olduğu sonucuna ulaşılmıştır.

Anahtar Kelimeler: Çevre eğitimi, aktif öğrenme, bilim kampı, bilimsel bilgi, bilimsel süreç becerileri.

Effect of Environmental Education Based on Transformational Learning Theory on Perceptions towards Environmental Problems and Permanency of Learning

Gökhan Uyanık*

Kastamonu University, Kastamonu, TURKEY

Received: March, 2016; Accepted: May, 2016

To cite this article: Uyanık, G. (2016). Effect of environmental education based on transformational learning theory on perceptions towards environmental problems and permanency of learning. *International Electronic Journal of Environmental Education*, 6(2), 126-140.

Abstract

The aim of the study is to determine effect of environmental education based on transformational learning theory on primary school teacher candidates' perceptions towards environmental problems and permanency of learning. Pretest-posttest quasi-experimental design have been used in this study. The study group consists of 66 teacher candidates who were continuing their education in fourth grade in Primary School Teaching Department of Faculty of Education in Kastamonu University in two different sections in fall term of 2014-2015 academic years. One of the section has been selected as experimental group (N=32) and the other section has been selected as control group (N=34) with random assignment method. Environmental problem knowledge test, responsibility behavior scale towards environment and the scale of attitude towards environmental problems have been used as data gathering tools. In order to compare average scores of the groups, t-test has been used for independent groups. According to findings, there was a statistically significant difference between experimental and control groups' knowledge and retention test in favor of experimental group. Also there was a statistically significant difference between experimental and control groups' responsibility scale and attitude scale scores in favor of experimental group.

Keywords: Attitude, environment, retention, transformational learning.

Introduction

Animals Increasing living standards and growing population of the world cause overuse of natural resources. Besides such an overuse, society's unconscious attitude towards environment makes environmental pollution inevitable. Needs of growing population like nutrition and housing accelerates natural source usage and causes significant environmental problems together. Nowadays, all of these problems become threat to whole world (Oweini & Hour, 2006).

Cars, which are getting their models updated every day, smartphones, new and powerful computers are creating consuming envy for people. In the time period we live, people are getting affected by a new product and join shopping madness. More than one television per house, computer, refrigerator and unused pair of shoes are only some of the unconscious consumer products. Production aspect of every consumer product, in other words, their effect on environment is ignored by many people (Çimen & Yılmaz, 2014). While the latest advanced developments in science and technology makes human life easier and more enjoyable, they are also affecting natural balance negatively. Considering human and environment relationship, it is seen that this

interaction continues from the day humans seen in nature till now. Environmental problems caused by increasing population, developments in technology and society's changing lifestyle and habits give rise to decrease on natural resources, decrease their quality and put all of the living systems under threat (Deniş & Genç, 2007).

At this point of environment quality, environmental education has significant role in decreasing and eliminating negative effects. Environmental education ensures increased awareness towards environmental activities and helps developing attitudes needed for solving environmental problems (Milton, Cleveland & Bennett-Gates, 1995). It is seen that traditional approaches to solve environmental problems are not successful. In recent years, different approaches have been under debate about environmental education and one of these approach is transformational learning theory (Çimen & Yılmaz, 2014).

Transformational learning theory has been developed by Mezirow (1978) for the first time. Adult learning is the basic property of this approach. Transformational learning is transforming people's mentality and emotion, thought, belief and knowledge related to their mentality and transforming knowledge to new approaches in learning process (Mezirow & Associates, 2000). By its challenging emerge, this theory which brings different aspects by criticizing established concepts on education from pedagogic perspective got attention from educational theorists and practitioners (Dirkx, 1998). In this theory, theorists like Dewey, Piaget, Bruner, Vygotsky and traces of constructivist principles can be seen. While the transformational learning theory can be seen as mixture of theories and models by its current state, it have had significant changes after it emerges firstly, and experimental and theoretical studies made in this topic integrate different aspects to this theory and these additions continues (Akpınar, 2010).

In the heart of the transformational learning theory, people's studies on their own with a critical point of view, evaluation of experiences and renaming by interpreting these experiences are located (Çimen & Yılmaz, 2014). Analyzes and self-assessments made in transformational process allows understanding of experiments that are referring actions. Elaboration or creating meaning is an important content on adult learning. Analysis and criticisms made in this social process by making experiments which cause these actions meaningful (Mezirow, 1994). According to Mezirow & Associates (2000) transformational learning process consists of 10 steps. These are: 1. Creating a dilemma. 2. Self-evaluation with guilty and emotion of shame (Evaluating yourself related to said topic by asking questions, for example, do I have enough knowledge on environmental topics or fears and concerns on this topic?). 3. Evaluating individual's assumptions with a broader aspect. 4. Awareness in transformation process. 5. Sharing thoughts on new roles, behaviors and relations. 6. Preparing a road map, a plan about what to do. 7. Gaining knowledge and skills in order to implement plans. 8. Trying new roles. 9. Building new roles, self-confidence relationship between individuals. 10. Appending new perspectives that individuals gained to their life.

Transformational process starts with creating dilemma. Dilemma which is creating process continues with self-scrutiny and evaluating assumptions with a critical point of view. Participant should know that creating dilemma process is a part of transformation. At this point, participant look for new roles, new relations and new actions in a conscious way. Participant should start a new learning course in order to pass these actions. In this course, knowledge and skills needed for these new roles and new plans are gained. Developing self-confidence and sufficiency is provided with the help of experiences related to new roles and relations. By this way, the participant includes new roles and relations that he gained into his life. If such a transformation happens in a correct way, this process is called as new perspective (McWhinney & Markos, 2003).

Transformational learning theory has been uncovered as a student's efforts to become a unique approach with several properties like self-motivated and self-governing, rational, empathic, in collaboration with scientific studies. This theory is based on how the individuals can make efficient judgment and gain foresight by learning how they can isolate themselves from untested ways of thinking in order to avoid it to stop their self-development (Akçay, 2012). Basic property of this theory is to ensure changing characteristics of the people and helping them to develop different point of view on life and experiences they have. In order to make recovery of the environmental problems and negativities, salvation of environment can happen by changing humans' point of view, attitude, knowledge, behavior, belief etc. towards environment (Çimen & Yılmaz, 2014).

According to many scientist, the reason of people on not behaving sustainable about environmental problems is their limited knowledge on environment and their inability to consider results of their actions (Williamson & Lynch, 2001). Recently, predicting environmental knowledge from environmental behaviors has been discussed. In some of the environment related studies, it is underlined that environmental knowledge is not effective on increasing awareness and environment related behavior on its own (Hungerford & Volk, 1990; Ramsey & Rickson, 1976). Besides the environmental knowledge, different factors effect environmental awareness and behavior (Hungerford & Volk, 1990).

There are a lot of studies in literature which studies different environmental education methods and their effects on environmental actions and behaviors. Keleş, Uzun & Varnacı-Uzun (2010) have studied the effects of environmental education on teacher candidates' environmental knowledge, attitudes and behaviors. Çimen & Yılmaz (2014) have studied effects of transformational learning theory on teacher candidates' perceptions towards environmental problems. In the study conducted by Dettman-Easler & Pease (1999), effects of outside learning activities on environmental attitudes of students have been studied. In their study conducted on adult individuals, Smith-Sebasto & Semrau (2004) have studied efficiency of environmental programs. Significant amount of studies from literature shows that environmental teaching programs are effective on developing positive attitude towards environmental awareness. In their studies, Çimen & Yılmaz (2014); Dresner & Gill (1994); Hungerford & Volk (1990); Jordan, Hungerford & Tomera (1986); Şimşekli (2004) underline that practices towards environmental problems increase students' environmental behavior positively.

In order to make the living-environment better, societies should be changed and a new environmental approach should be developed. Human-being should be the basic object of this change. By this way, individual and social change can be fulfilled by building awareness in different layers of society (Çimen & Yılmaz, 2014). In this context, environmental education based on transformational learning theory which is based on individual's all characteristics and their transformation are needed. It is seen that studies about transformational learning theory are outnumbered in literature. It is believed that this study in which effects of transformational learning theory on learning process and teacher candidates' environmental responsible behavior will be beneficial to literature. From this opinion, aim of the study is to determine effects of environmental education based on Transformational Learning Theory on primary school teacher candidates' perceptions towards environment and permanency of learning. For this aim, answers for sub-problems listed below were tried to be found:

Experimental and control groups';

1) Is there any significant difference between knowledge test of environmental problems, behavior scale and attitude scale pre-test scores?

- 2) Is there any significant difference between knowledge test of environmental problems, behavior scale and attitude scale post-test scores?
- 3) Is there any significant difference between retention test results?

Methodology

Model of Study

Pretest-posttest quasi-experimental design have been used in this study. Fraenkel & Wallen (2006) states that the underlying basic idea of all of these experimental studies is “trying something and observe what happened in a systematic way”. In line with this idea, effects of environmental education based on transformational learning theory on primary-school teacher candidates’ perceptions towards environmental problems and permanency of learning have examined. While learning process happens in a teacher-centered way in control group, environmental education based on transformational learning theory has been used in experimental group. Symbolic view related to study’s experimental pattern is shown in Table 1.

Table 1.

Symbolic view related to study’s experimental pattern

<i>Group</i>	<i>Pre-test</i>	<i>Procedure</i>	<i>Post-test</i>	<i>Retention test</i>
Experimental	T1 - S1 - S2	X	T1 - S1 - S2	T1
Control	T1 - S1 - S2	-	T1 - S1 - S2	T1

T1: Environmental Problems Knowledge Test

S1: Responsibility Behavior Scale to Environment

S2: Attitude Scale towards Environmental Problems

X: Environmental Education Based on Transformational Learning Theory

Working Group

The working group consists of 66 teacher candidates who were continuing their education in fourth grade in Primary School Teaching Department of Faculty of Education in Kastamonu University in two different sections in fall term of 2014-2015 academic year. While 32 of the teacher candidates from two separate section were in experimental group, 34 teacher candidates from other section were in control group. Groups were selected randomly.

Data Gathering Tools

In this study, “Environmental Problems Knowledge Test” (EPKT), “Responsibility Behavior Scale to Environment” (RBSE) have been used as data gathering tools, which were developed by Çimen (2013). Moreover “Attitude towards Environmental Problems Scale” (AEPS) has been used as data gathering tool, which was developed by Şama (2003).

EPKT has been used in order to determine teacher candidates’ academic achievement level related to environmental problems. There are 25 questions in EPKT. KR-20 reliability value of the test is .74. Expert opinions have been taken in order to ensure the content validity of the test. Correct answers of the test problems have been marked as ‘4’ points. By this way, maximum score which can be got from this test is ‘100’.

RBSE has been used in order to determine environmental responsibility scale of teacher candidates. Scale consist of 11 entries and it is quintet Likert type. After validity and reliability tests, Kaiser-Meyer-Olkin (KMO) coefficient of the scale has been detected as .789 and Bartlett Sphericity test meaningfulness scale has been detected as 0.00. The scale consist of three factors. Total described variance of these factors has been calculated as 61.1%. Cronbach Alpha (α) reliability coefficient of RBSE has been found as .79. After a scan of literature and contents of the expressions from the scale, scale factors were named as environmental concern, environmental protection and recycling. For the content validity of the scale, opinions of expert academicians have been used. The most positive response of the scale has been coded as '5' points. By this way, maximum score which can be got from this scale is '55'. The most negative response of the scale were coded as '1' points. By this way the lowest score which can be got from this scale is '11'.

AEPS has been used in order to determine teacher candidates' attitude towards environmental problems. AEPS consists of 21 entries. Scale is quintet likert type, choices from scale have been determined as "absolutely disagree", "disagree", "undecided", "agree" and "absolutely agree". While '10' entries from the scale are negative, other '11' entries are positive. It is a single dimension and Cronbach Alpha (α) reliability value has been calculated as .77. Expert opinions have been used in order to provide content validity of the scale. The most positive response of the scale has been coded as '5' points. By this way, maximum score which can be got from this scale is '105'. The most negative response of the scale have been coded as '1' points. By this way, the lowest score which can be got from this scale is '21'.

Implementation Process

Experimental process of this study took 10 weeks. In the experimental process, lectures were held in a teacher-centered format by using lecturing method for control group. However, in the experimental group, lectures were held by environmental education based on transformational learning theory.

In the transformational learning theory scope, writing and reading biography, self-evaluation, recycling center trip, nature trip, problem-based activities, scenario activities, educational games activities, selected topic presentation and worksheets activities have been conducted. By biography writing activities, primary-school teacher candidates reflect their existing knowledge on environmental problems in a multidirectional way. In biography writing activities, they have seen each other's assumptions and made sharing about it. Self-evaluation activities provide self-inspection opportunity with a critical point of view to pre-school teacher candidates with the help problem-based activities, scenario and educational games activities which they develop diverse point of view on environmental problems. Recycling center trip and nature trip are effective on developing environmental awareness. Selected topic presentations and worksheets activities have been conducted transformation of environmental problem related knowledge of primary-school teacher candidates. Eight weeks after experimental application process, environmental problems knowledge test have been conducted on both experimental and control groups again as retention test.

Analyzing Data

SPSS 21.0 statistical software package has been used to analyze the data in this study. Independent t-test analysis has been applied in order to compare scores of control and experimental groups. Findings have been tested on $p < .05$ significance level.

Findings

Findings Related to First Sub-Problem

Is there any significant difference between knowledge test of environmental problems, behavior scale and attitude scale pre-test scores? In order to compare environmental problems knowledge test's pre-test scores of experimental and control groups, independent t-test has been used. Data related to this analysis is shown in Table 2.

Table 2.

Independent t-test result regarding environmental problems knowledge test pre-test scores of experimental and control group

Group	N	M	SD	df	t	p
Experimental	32	36.87	8.48	64	-1.118	.271
Control	34	39.52	10.73			

According to Table 2, it is seen that there is not any significant difference on comparison of environmental problem knowledge tests' pre-test scores of experimental and control groups ($t_{(64)} = -1.118$; $p > .05$). According to such findings, it can be said that the experimental and control group had same level on knowledge variable before the experimental process.

In order to compare regarding responsibility behavior scale to environment pre-test scores of experimental and control groups, independent t-test has been used. Data related to this analysis shown in Table 3.

Table 3.

Independent t-test result regarding responsibility behavior scale to environment pre-test scores of experimental and control group

Group	N	M	SD	df	t	p
Experimental	32	28.93	4.97	64	.708	.481
Control	34	28.08	4.76			

Results from data analysis of Table 3 show that there is not any significant difference between experimental and control groups' pre-test values about responsibility behavior scale to environment ($t_{(64)} = .708$; $p > .05$). Starting from this finding, it can be said that both groups have equal level of responsibility behavior to environment awareness before the experimental process.

In order to compare attitude towards environmental problems pre-test scores of experimental and control groups, independent t-test was used. Data related to this analysis is shown in Table 4.

Table 4.

Independent t-test result regarding attitude scale towards environmental problems pre-test scores of experimental and control group

<i>Group</i>	<i>N</i>	<i>M</i>	<i>SD</i>	<i>df</i>	<i>t</i>	<i>p</i>
Experimental	32	57.31	6.01	64	-1.181	.242
Control	34	59.02	5.79			

Results from data analysis of Table 4 shows that there is not any significant difference between experimental and control groups' pre-test values about attitude towards environmental problems ($t_{(64)} = -1.181$; $p > .05$). According to this finding, it can be said that both groups have equal level of attitudes towards environmental problems before the experimental process.

Findings Related to Second Sub-Problem

Is there any significant difference between knowledge test of environmental problems, behavior scale and attitude scale post-test scores? In order to compare environmental problem knowledge test post-test scores of experimental and control groups, independent t-test was used. Data related to this analysis shown in Table 5.

Table 5.

Independent t-test result regarding environmental problems knowledge test post-test scores of experimental and control group

<i>Group</i>	<i>N</i>	<i>M</i>	<i>SD</i>	<i>df</i>	<i>t</i>	<i>p</i>
Experimental	32	82.12	8.67	64	4.491	.000*
Control	34	71.41	10.52			

In Table 5, it is seen that there is a significant difference between environmental problems knowledge test post-test scores of experimental and control groups and it can be said that this significant difference is in behalf of experimental group ($t_{(64)} = 4.491$; $p < .05$). According to this finding, environmental education based on the transformational learning theory can be said to be quite effective to increasing knowledge of environmental issues.

In order to compare responsibility behavior scale to environment post-test scores of experimental and control groups, independent t-test was used. Data related to this analysis is shown in Table 6.

Table 6.

Independent t-test result regarding responsibility behavior scale to environment post-test scores of experimental and control group

<i>Group</i>	<i>N</i>	<i>M</i>	<i>SD</i>	<i>df</i>	<i>t</i>	<i>p</i>
Experimental	32	49.43	4.13	64	2.722	.008*
Control	34	46.55	4.43			

In Table 6, it is seen that there is a significant difference between responsibility behavior scale to environment post-test scores of experimental and control groups and it can be said that such a significant difference is in behalf of experimental group ($t_{(64)}=2.722$; $p<.05$). According to this finding, environmental education based on the transformational learning theory can be said to be quite effective to increasing responsibility behavior to environment. The experimental and control groups' changes of responsibility behavior to environment in the experimental process can be seen as a column chart in Figure 1.

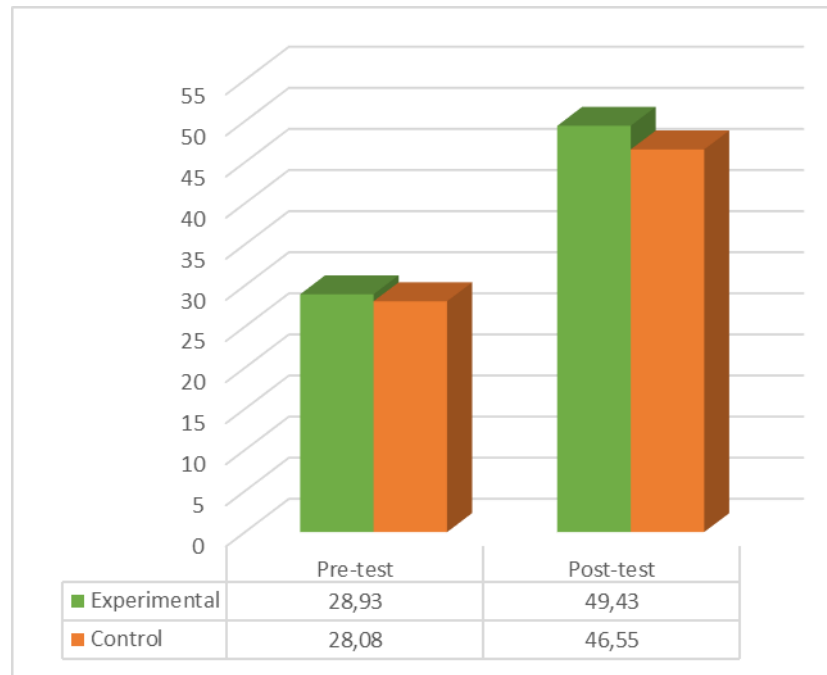

Figure 1. The experimental and control groups' changes of responsibility behavior to environment

When examining Figure 1, it is seen that the experimental and control groups were similar levels of sensitivity to the environment before the experimental implementation. However, it is said that the experimental group have more sensitive behavior towards the environment after the experimental application process. Accordingly, it can be said that the teaching based on transformational learning theory, which has been applied in the experimental group was more effective than the teacher centered method.

In order to compare attitude scale towards environmental problems post-test scores of experimental and control groups, independent t-test was used. Data related to this analysis shown in Table 7.

Table 7.

Independent t-test result regarding attitude scale towards environmental problems post-test scores of experimental and control group

<i>Group</i>	<i>N</i>	<i>M</i>	<i>SD</i>	<i>df</i>	<i>t</i>	<i>p</i>
Experimental	32	96.03	9.08	64	3.262	.002*
Control	34	88.14	10.45			

In Table 7, it is seen that there is a significant difference between attitude towards environmental problems post-test scores of experimental and control group and it can be said that this significant difference is in behalf of experimental group ($t_{(64)} = 3.262$; $p < .05$). According to this finding, environmental education based on the transformational learning theory can be said to be quite effective to increasing positive attitudes towards environmental problems. The experimental and control groups' changes of attitudes towards environmental problems in the experimental process can be seen as a column chart in Figure 2.

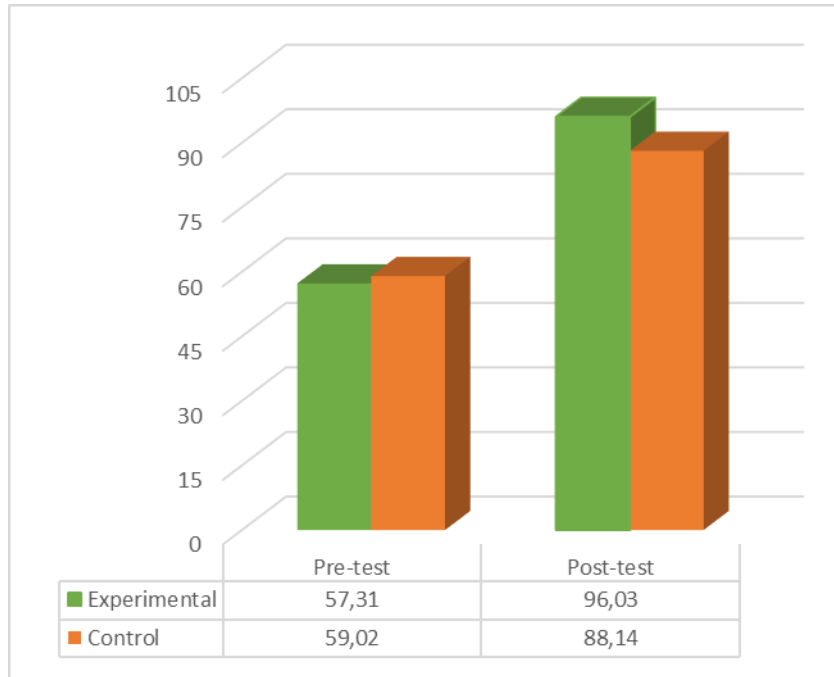

Figure 2. Changes the attitudes towards environmental problems of experimental and control groups

When looking at the Figure 2, it is seen that the experimental and control groups were similar levels of attitudes towards environmental problems before the experimental process. But after the experimental implementation process, it is said that the experimental group have more positive attitudes towards the environmental problems. According to this, it can be said that the teaching based on transformational learning theory, which was applied in the experimental group, quite effective than the teacher centered method.

Findings Related to Third Sub-Problem

Independent t-test was used in order to compare environmental problems knowledge retention test scores of experimental and control groups. Data related to this analysis shown in Table 8.

Table 8.

Independent t-test result regarding environmental problems knowledge retention test scores of experimental and control group

Group	N	M	SD	df	t	p
Experimental	32	76.62	2.29	64	16.654	.000*
Control	34	50.94	8.43			

In Table 8, it is seen that there is a significant difference between environmental problems knowledge retention test scores of experimental and control group and it can be said that such a significant difference is in behalf of experimental group ($t_{(64)}=16.654$; $p<.05$). According to this finding, environmental education based on the transformational learning theory can be said to be quite effective to increasing permanency of learnings. The experimental and control groups' changes of environmental problems knowledge levels within a total of 18 weeks in the process can be seen as a line chart in Figure 3.

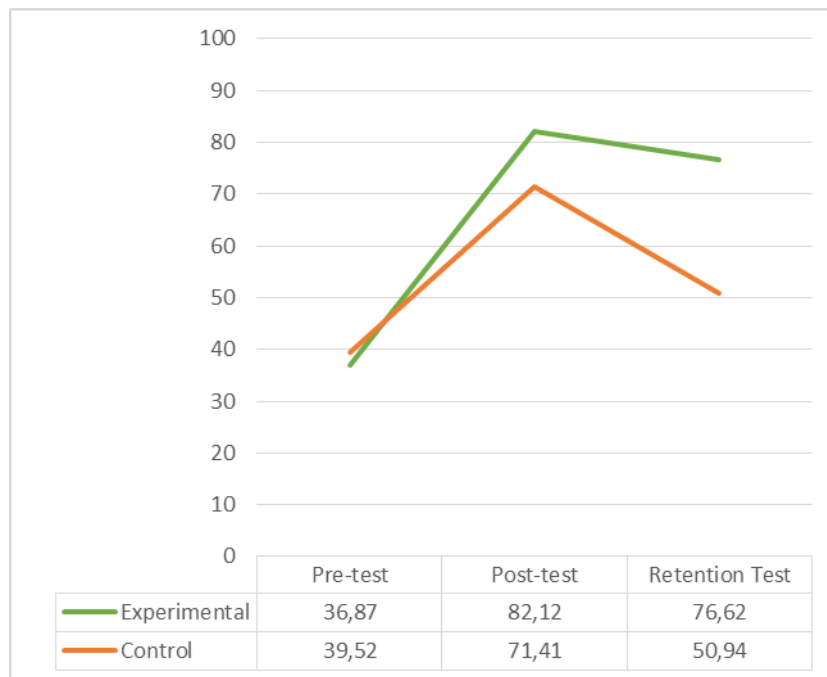

Figure 3. Changes the environmental problems knowledge levels of experimental and control groups

When looking at the Figure 3, it is seen that the experimental and control groups were similar levels to knowledge of environmental problems before the experimental

application. However, knowledge on the environmental problems of the experimental group showed more increase after the experimental application process. Even more, retention test was conducted after 8 weeks of the experimental implementation process and according to the result of this test, the success level of the experimental group fell slightly. However, the score of the control group showed quite a lot of decline. Accordingly, it can be said that the teaching based on transformational learning theory, which has been applied in the experimental group, was quite effective to provide permanency of learning.

Results and Discussion

One of the most challenging problem in today's world is the environment's negative transformation caused by humans. Environmental problems are not only belong to an individual, a society or a nation, they also belong to all universe together. There are lots of precautions to stop human negative effects on environment and different environmental education approaches are the basic method to bringing them to daily life. Also, in this study, a new teaching method, environmental education based on transformational learning theory's effects on primary-school teacher candidates' attitudes towards environmental problems and permanency of the environmental knowledge have been learned in the learning process. The results obtained at the end of the study are described below. Before the experimental application, it was detected that both study and control group have similar awareness level from pre-test, in other words, it was seen that both groups have same level of properties on said areas before the experimental process.

Palmer (1998) underlines that one of the most important aspect of humans' perceptions towards environment is their related knowledge level. While there is not any difference on environmental knowledge variable between both groups before the experimental process, when analyzing the post-test scores, it is seen that there is a statistically significant difference on environmental knowledge variable on behalf of experimental group. This results can be explained as in environmental education based on transformational learning theory is more effective than lecturing method. Such a result is supporting result of studies conducted by Feinstein (2004) and Çimen & Yılmaz (2014). Feinstein (2004) underlines that environmental education based on transformational learning theory improves students' regional environmental knowledge. In their study, Çimen & Yılmaz (2014) concluded that environmental education based on transformational learning theory provided better results than lecturing method.

One of the important element of transformational learning theory is human's emotional properties (Neuman, 1996). Outdoor activities like nature trip and video and photography review activities are considered to be helpful in developing environmental related awareness in study group. In their study, Collins et al. (2008) has found that activities based on transformational learning theory are helpful for developing positive behavior towards protecting environment in local people of Africa. The study conducted by Wyneen, Kylee & Tarrant (2012) and D'Amato & Krasny (2011) indicates that environment education based on transformational learning theory and activities related to it are helpful for developing positive changes on students' environmental responsibility behaviors.

Also in this study, after analyzing findings related to environmentally responsible attitude, it is stated that environmental education based on transformational learning theory has affected experimental group positively. In other words, after the experimental process, it is seen that experimental group have developed more awareness towards environmentally responsible attitude.

At the end of the study, significant increase at post-test results is seen both experimental and control group. It is said that such an increase has occurred in experimental group. However, according to retention test held after 8 weeks after the post-tests, scores difference between experimental and control groups has been significantly increased in behalf of experimental group. This result shows that environmental education based on transformational learning theory provides more permanent learning. If the retention could not be achieved, knowledge and behavior gained would be forgotten and the efforts and time spent in learning process would be wasted. In this context, importance of retention is underlined. As a result, it is understood that study group has increased their knowledge on environmental problems and environmentally responsible behavior has increased significantly with the environmental education based on transformational learning theory. In addition to this, it is determined that permanency of learnings and positive behaviors have been gained because of based on this theory.

Based on the results obtained in this study, importance of including implementations based on transformational learning theory when planning environmental learning techniques and its positive outcomes can be stated. In this scope, student-centered activities like nature walks, photography and video showing, news related to environment should be taken seriously. Especially, considering nature walking activity's positive effect on study group's emotions towards environment, nature-based activities will be very beneficial for environmental education applications. Additionally, self-evaluation activities let students make assessment about themselves. Such a kind of activities can be used in order to let students develop awareness themselves. Reflective thinking activities, scenario, photography and video study, writing biography also can be used in environmental education courses to reveal students' knowledge and environment related behavior.

. . .

References

- Anning, A. & Ring, K. (2004). *Making sense of children's drawings*. Berkshire: Open University.
- Bowker, R. (2007). Children's perceptions and learning about tropical rainforests: An analysis of their drawings. *Environmental Education Research*, 13(1), 75-96.
- Akçay, R. C. (2012). Transformational learning theory and transformation in adult education. *Journal of National Education*, 196, 5-19.
- Akpınar, B. (2010). Transformative learning theory: transformed and changed learning. *Anatolian University Journal of Social Science*. 10(2), 185-198.
- Collins, T.D., Gaved, M.B., Mulholland, P., Kerawalla, L.J., Twiner, A., Scanlon, E., Jones, A., Littleton, K., Conole, G., & Tosunoglu, C. (2008). *Supporting location-based inquiry learning across school, field and home contexts*. In Proceedings of the 7th World Conference on Mobile and Contextual Learning (mLearn-2008), Telford, UK.
- Çimen, O. (2013). *Impact on the perception of environmental problems of biology teachers candidates in environmental education based on the transformational learning theory*. (Unpublished Doctoral Dissertation). Gazi University Institute of Educational Sciences, Ankara.
- Çimen, O., & Yılmaz, M. (2014). The influence of transformative learning based environmental education on pre-service biology teachers' perception of environmental problems. *Bartın University Journal of Education Faculty*, 3(1), 339-359.

- D'Amato, L. G., & Krasny, M. E. (2011). Outdoor adventure education: Applying transformative learning theory to understanding instrumental learning and personal growth in environmental education. *The Journal of Environmental Education, 42*(4), 237-254.
- Deniş, H., & Genç, H. (2007). Comparison the achievements of the environmental science and attitudes towards the environment and environmental science students take classes taught this course. *Mehmet Akif Ersoy University Faculty of Education Journal, 8*(13), 20-26.
- Dettman-Easler, D., & Pease, J. (1999). Evaluating the effectiveness of residential environmental education programs in fostering positive attitudes toward wildlife. *The Journal of Environmental Education, 31*(1), 33-39.
- Dirkx, J. M. (1998). Transformative learning theory in the practice of adult education: An overview. *Journal of Lifelong Learning, 7*, 1-14.
- Dresner, M., & Gill, M. (1994). Environmental education at summer nature camp. *The Journal of Environmental Education, 25*(3), 354-1.
- Feinstein, B. C. (2004). Learning and transformation in the context of Hawaiian traditional ecological knowledge. *Adult Education Quarterly, 54*(2), 105-120.
- Fraenkel, J. R., & Wallen, N. E. (2006). *How to design and evaluate study in education*. (6. Ed.). New York: McGraw-Hill International Edition.
- Hungerford, H. R., & Volk, T. L. (1990). Changing learner behavior through environmental education. *The Journal of Environmental Education, 21*(3), 8-21.
- Jordan, J. R., Hungerford, H. R., & Tomera, A. N. (1986). Effects of two residential environmental workshops on high school students. *The Journal of Environmental Education, 18*(1), 15-23.
- Keleş, Ö., Uzun, N., & Varnacı-Uzun, F. (2010). Evaluating environmental awareness of teacher candidates, environmental attitudes, thinking and behavior of the project depends on the nature of education exchange and permanence. *Electronic Journal of Social Sciences, 9*(32), 384-401.
- McWhinney, W., & Markos, L. (2003). Transformative education across the threshold. *Journal of Transformative Education, 1*(1), 16-37.
- Mezirow, J., & Associates. (2000). *Learning as transformation*. San Francisco: Jossey-Bass.
- Mezirow, J. (1994). Understanding transformation theory. *Adult Education Quarterly, 44*(4), 222-23.
- Milton, B., Cleveland, E., & Bennett-Gates, D. (1995). Changing perceptions of nature, self, and others: A report on a park/school program. *Journal of Environmental Education, 26*(3), 32-42.
- Neuman, T. (1996). *Critically reflective learning in a leadership development context*. (Unpublished Doctoral Dissertation). University of Wisconsin, Madison, Wisconsin.
- Oweini, A., & Hourri, A. (2006). Factors affecting environmental knowledge and attitudes between Lebanese college students. *Applied Environmental Education and Communication, 5*, 95-105.
- Palmer, J.A. (1998) *Environmental education in the 21st century: Theory, practice, progress, promise*. London: Routledge.
- Ramsey, C. E., & Rickson, R. E. (1976). Environmental knowledge and attitudes. *Journal of Environmental Education, 8*, 10-18.
- Smith-Sebasto, N. J., & Semrau, H. J. (2004). Evaluation of the environmental education program at the New Jersey school of conservation. *Journal of Environmental Education, 36*(1), 3-18.
- Şama, E. (2003). Attitudes towards environmental problems of teacher candidates. *Journal of Gazi University Faculty of Education, 23*(2), 99-110.

- Şimşekli, Y. (2004). For the development of environmental awareness, sensitivity to environmental education activities for primary schools. *Journal of Uludağ University Faculty of Education*, 17(1), 83-92.
- Williamson, D., & Lynch-Wood, G. (2001). A new paradigm for some environmental practice. *Journal of the TQM*. 13(6), 424-432.
- Wynveen, C., Kyle, G. T., & Tarrant, M. A. (2012). Study abroad experiences and global citizenship fostering pro-environmental behavior. *Journal of Studies in International Education*, 16(4), 334-352.

Dönüşümsel Öğrenme Kuramına Dayalı Çevre Eğitiminin Çevre Sorunlarına Yönelik Algılara Ve Öğrenmenin Kalıcılığına Etkisi

Gökhan Uyanık

Kastamonu Üniversitesi, Kastamonu, Türkiye

Özet

Bu araştırmanın amacı, dönüşümsel öğrenme kuramına dayalı çevre eğitiminin sınıf öğretmeni adaylarının çevre sorunlarına yönelik algılarına ve öğrenmenin kalıcılığına etkisini belirlemektir. Araştırmada öntest-sontest kontrol gruplu yarı deneysel desen kullanılmıştır. Çalışma grubu, 2014-2015 eğitim-öğretim yılı güz döneminde Kastamonu Üniversitesi Eğitim Fakültesi Sınıf Öğretmenliği lisans programında dördüncü sınıfta iki farklı şubede öğrenim gören 66 öğretmen adayından oluşmaktadır. Şubelerden biri deney (N=32), diğeri kontrol grubu (N=34) olarak seçkisiz atama yoluyla belirlenmiştir. Deneysel uygulama süreci boyunca deney grubunda dersler dönüşümsel öğrenme kuramına dayalı olarak işlenirken, kontrol grubunda öğretmen merkezli eğitim verilmiştir. Veri toplama araçları olarak çevre sorunları bilgisi testi, çevreye duyarlı davranış ölçeği ve çevre sorunlarına yönelik tutum ölçeği kullanılmıştır. Verilerin analizinde SPSS 21.0 istatistik paket programından yararlanılmıştır. Grupların ortalama puanlarını karşılaştırmak amacıyla bağımsız gruplar için t-testi kullanılmıştır. Elde edilen bulgulara göre, deney ve kontrol grubunun çevre sorunları bilgisi testi, çevre sorunlarına yönelik duyarlılık ölçeği ve çevre sorunlarına yönelik tutum ölçeği son-test puanları arasında deney grubu lehine istatistiksel olarak anlamlı bir fark olduğu belirlenmiştir. Bu sonuca bakarak, dönüşümsel öğrenme kuramına dayalı çevre eğitiminin, öğretmen merkezli eğitime göre akademik başarı, çevre sorunlarına duyarlılık ve çevreye sorunlarına yönelik olumlu tutumların geliştirilmesi bakımından daha etkili olduğu söylenebilir.

Anahtar Kelimeler: Tutum, çevre, kalıcılık, dönüşümsel öğrenme.

An Assessment of Turkish Elementary Teachers in the Context of Education for Sustainable Development*

Ali SAGDIC**

Middle East Technical University, Ankara, Turkey

Elvan SAHİN

Middle East Technical University, Ankara, Turkey

To cite this article: Sagdıç, A. & Şahin, E. (2016). An assessment of Turkish elementary teachers in the context of education for sustainable development. *International Electronic Journal of Environmental Education*, 6(2), 141-155.

Abstract

The purpose of the current study is to describe beliefs, perceived barriers and teaching strategy preference of elementary teachers with respect to education for sustainable development. The sample of research survey consisted of 211 elementary teachers who are also participant of projects on environmental education entitled Green Pack and Eco-schools. The data were collected by three different scale entitled "beliefs on education for sustainable development scale", "barriers towards education for sustainable development scale" and "techniques in education for sustainable development scale". Items of the scales were examined taking into account mean scores, standard deviation, frequencies and percentages. Results revealed that teachers perceive some of the condition such as curriculum, class size, and lack of instructional materials as barriers for education for sustainable development. Despite these barriers, teachers have favorable beliefs regarding education for sustainable development. These beliefs were in line with the standards portrayed by international reports. In addition, it was argued that teachers' beliefs may be shaped by the educational projects they participated in.

Keywords: Elementary teachers, Teaching beliefs on sustainable development, teaching techniques

Introduction

It has been declared that the earth is a unique planet in terms of life opportunities that it provides for every creature. More specifically, any other planet in the solar system does not have proper condition for vividness. However, the recent phenomenon such as floods, decreasing water quality, winter storms and tornados, wars and terrorism we face showed that living on the earth become also more challenging when compared to previous years.

Recent reports indicate that the number of the people suffered from poor water sources and insufficient sanitation are much greater than people exposed to wars and similar violence. According to World Health Organization (WHO), for instance, 11% of the world still could not access any types of water supply. In terms of sanitation, 36% of the world population could not reach these facilities. Inappropriate sanitation conditions, lack of hygiene, and unsafe water increase the number of the people suffered from infectious

ISSN: 2146-0329

*This study is a part of the thesis entitled "A Closer Look into Turkish Elementary Teachers Regarding Education for Sustainable Development" approved by Middle East Technical University Graduate School of Social Sciences, presented as an oral presentation in The European Conference on Educational Research (ECER) 2013, and funded by Middle East Technical University Scientific Research Office (ODÜ-BAP-07-03-2012-103).

**E-mail: sagdic.ali@gmail.com

diseases. These diseases unfortunately end up with death particularly in Africa and some part of South-East Asia (WHO, 2015). In addition to these problems, extinction of species; unfair distribution of wealth; air, soil and water pollution, and deforestation could be exemplified for the reasons of why life conditions on our planet have become so difficult.

It is revealed that these issues are generally linked to interactions among environmental, social and economic conditions. In this aspect, “sustainable development” has emerged as a comprehensive solution for challenges we face. The term sustainable development is gradually changing over time which causes an obstacle in clarifying the term. “Sustainable development” was primarily stated in the document World Conservation Strategy (IUCN, WWF, & UNEP, 1980) that demonstrated conservation as a way to attain development and serve especially for the goals of sustainable development, and wise usage of natural resources and ecosystems. “Sustainable development” has become a widely known concept since the World Commission on Environment and Development (WCED) reported about sustainability in 1987. Its report was titled with Our Common Future and it was stated that *“Sustainable development is development which meets the needs of the present without comprising the ability of future generations to meet their own needs”* (WCED, 1987, p.43). The brief definition of sustainable development by WCED implies that human needs are basic and essential. Furthermore, economic development accompanied by equity to share resources with poor nations should be maintained and the equity should be encouraged by effective citizen participation. In order to embrace sustainable development in our social and individual life, education has appeared as a key agent since it is a unique way to change human behavior, to develop reasoning and judgment abilities and to teach concepts. Therefore, Council for Environmental Education (1998) describes education for sustainable development (ESD) as a way to improve humans’ knowledge, values, and skills in order to improve the life standards without damaging the planet.

ESD corresponds to more than knowledge of social, environment and economy issues. It also contains values, problem solving skills, critical thinking skills, and local and global viewpoints towards issues. Moreover, ESD focuses on the importance of democracy and participation of people in democratic societies. Sustainable development includes controversial issues and complex systems; therefore, teachers should be well equipped with the qualifications required for effective implementations of ESD (Bertschy, Künzli, & Lehmann, 2013).

Teachers’ beliefs are among the significant qualifications, since teachers are regarded as an agent for supporting community participation to achieve the goals of sustainable development (Taylor, Nathan, & Coll, 2003). Considering this point of view, it was revealed that ‘teacher beliefs’ attracted the attention of many researchers from various disciplines though the definition of ‘belief’ construct is open to debate. The definition of this term which shaped the present study belongs to (Pehkonen & Törner, 1996, p.6). These authors claimed: *“Beliefs are composed of a relatively long-lasting subjective knowledge of certain objects as well as the attitudes linked to that knowledge. Beliefs can be conscious or unconscious, whereby the latter type are often distinguished by an affective character”*. In general, beliefs have cognitive, affective and behavioral components; influence knowledge, acts and feelings (Johnson, 1999). According to Pajares (1992), all teachers have beliefs concerning teaching, students and their responsibilities. Moreover, previous studies emphasized that teachers’ beliefs influence their classroom activities, learning and teaching process (Pajares, 1992; Richardson, 1996; Thompson, 1984).

Concerning the potential impact of beliefs on teachers’ implementations, some studies (e.g., Boon, 2011; Corney & Reid, 2007; Summers, Corney, & Childs, 2003; Winter &

Firth, 2007; Zachariou & Valanides, 2006) were also conducted in order to reveal teachers' beliefs on ESD. These studies indicated that teachers do not have consensus with respect to different aspects of ESD. For instance, some teachers believed that local issues were more suitable to be included in the teaching practices regarding sustainability in that students could easily associate these issues with their daily life. On the other hand, some teachers held another point of view in that global issues were more interesting among students (Summers et al., 2003). However, teachers generally agreed that sustainable development is abstract and difficult to conceptualize (Winter & Firth, 2007; Zachariou & Valanides, 2006). It is stressed that some of the terms in the content of sustainable development such as democracy, equality, sustainability, and prosperity makes it more challenging to acquire proper understandings of sustainable development (Summers, Corney, & Childs, 2004).

Although teachers stressed that students had difficulty in conceptualizing sustainable development and its sub-components, they also emphasized that there were topic and subject specific teaching strategies which facilitate students' learning. For instance, ecological footprint activities contribute development of awareness towards equal and fair consumption (Corney & Reid, 2007); case studies including debatable issues contribute students' understanding of global and local issues (Corney & Reid, 2007); enhance critical thinking abilities, and enhance students' awareness to their own attitude and values (Summers et al., 2003). Although these strategies were suggested in the context of ESD, they did not guarantee students' learning since these strategies require active participation of students. Therefore, teachers should motivate their students for their active participation and improve their performance in these activities. However, teachers stressed that students generally have low expectation and not aware of their own potential performance (Corney, 2006; Summers et al., 2003).

Teachers do not have similar belief regarding the implementations of ESD. To be more specific, the role of their own values and principles on implementations of ESD are among the controversial issues in this context. For instance, teachers are not sure whether or not they should share their own ideas about a specific sustainability-related issue and how their ideas might influence students' critical thinking skills and values (Corney, 2006; Summers et al., 2003; Winter & Firth, 2007). Some teachers believe that they should not express their thoughts and ideas. Rationale behind this idea is that students should develop their own ideas and values without dictate. On the one hand, some of them believe that explaining correct ideas and principles may be helpful for students learning (Summers et al., 2004).

In addition to teachers' different beliefs on ESD, they also face with different difficulties. The studies (e.g., Corney, 2006; Summers, Childs, & Corney, 2005) point out that teachers perceive lack of knowledge, lack of supports of the heads of the schools, inconsistency between teaching academic fields and sustainable development, and their personal characteristics as a barrier towards ESD. To overcome these barriers, teachers should be well equipped with necessary qualifications by means of professional support. Some of the non-governmental organizations, therefore, support teachers' professional repertoire with respect to ESD.

The project of the Eco-School arranged by Turkish Environmental Education Foundation and the Project of Green Pack arranged by The Regional Environmental Center (REC) are widespread projects trying to improve the quality of the ESD. The Green Pack Project provides a curriculum kit including educational materials for both teachers and students. This kit includes lesson plans, animations and short movies, teacher guide books, games and interactive educational tools. In addition, REC provided some training programs in order to enhance effective usage of these materials. Teachers were informed about how to use these documents and how to integrate them into their own lessons. On the one

hand, the content of the Eco-School project assures cooperation between teachers, students, school managers and also parents. The aim of the school is to obtain the Green Flag Award which refers sustainability of the school. In order to obtain this flag a coordinator teachers manage responsibilities of each teachers and students in a specific tasks. As a consequences of their work, they reports their progressions to official of the project.

In the current study, the research questions were determined to examine Green Pack and Eco-School coordinator teachers' beliefs with respect to education for sustainable development. The following research questions guided the current study;

1. What is the Turkish elementary teachers' beliefs on education for sustainable development?
2. Which strategies have been preferred by Turkish elementary teachers in the context of education for sustainable development?
3. Which contextual variables have been perceived as barriers by Turkish elementary teachers?

Methodology

Participants

The current study utilized a survey research method in order to describe elementary teachers' perspective towards ESD. A total of 211 elementary teachers from thirteen different teaching fields responded to the survey. Considering all elementary teachers do not have appropriate and sufficient understanding regarding education for sustainable development, the participant of the study was chosen from two environmental education projects entitled with the Green Pack and the Eco-School projects. There were 145 Green Pack teachers participating in the current study while the number of the Eco-School coordinator teachers were 96. It was revealed that 31 teachers were the members of both projects.

The convenience sampling method was preferred as sampling method in the present study. Measurement tool was converted to an online-survey and then sent to teachers as an email. As far as thirteen teaching fields were considered, percentages of Classroom Teachers with 44.5% (n= 94) and then, Science Teachers with 17.5 (n=37) were larger groups, while Special Education and Preschool were .5% (n=1).

Measurement tool

The measurement tool used in the present study consisted of three different scales. Data were collected using these parts namely, "beliefs on education for sustainable development scale", "techniques in education for sustainable development scale", "perceived barriers towards education for sustainable development scale". Beliefs on education for sustainable development scale was developed by Sađdıç and Şahin (2015), which is a five-point Likert type ranging from scores '1' to '5'. '1' corresponded to strongly disagree (SD), '2' corresponded to disagree (D), "3" corresponded to undecided (U), "4" corresponded to agree (A) and "5" corresponded to strongly agree (SA). The scale includes 32 items and three factors such "beliefs on implementation of sustainable development", "beliefs on limitation of sustainable development" and "beliefs on adequacy of education for sustainable development in Turkish education system". Confirmatory factor analysis ($X = 937,85$, $df = 457$, $p = 0.000$; $CFI = 0.92$, $RMSEA = 0.71$), discriminant and convergent validity analysis conducted by researchers indicate that beliefs on education for sustainable development scale is a valid scale to assess teachers' beliefs.

Another measurement tool is “barriers towards education for sustainable development scale” was developed to examine the barriers that the teachers have perceived during education for sustainable development in the formal education process. Ten items were adopted from the instrument entitled *“Teachers’ Perceptions of Teaching Environmental Issues within the Science Curriculum: A Hong Kong Perspective”* (Ko & Lee, 2003). Furthermore, other five were constituted considering findings of the study titled *“Education for Sustainability: An Approach to the Professional Development of Teachers”* (Gayford, 2001). The items were scored with seven point Likert-scales. Score “1” reflected that barrier was very eligible for me and score “7” reflected that barrier was not at all eligible for me.

Techniques in education for sustainable development scale was used to measure teachers’ preference on teaching techniques utilized in ESD. Appropriate techniques for education for sustainable development were determined in the light of the book which titled *“Handbook on Methods Used in Environmental Education and Education for Sustainability”* (Scoullous & Malotidi, 2004) and the article which titled *“Teachers’ Perceptions of Teaching Environmental Issues within the Science Curriculum: A Hong Kong Perspective”* (Ko & Lee, 2003). Three options were presented for each technique as “have used”, “have not used but would like to use” and “have not used because it is not appropriate for ESD”.

Analysis

Teachers responses to scales of the current study were examined by means of an item based assessment. The mean scores, the standard deviations, frequencies and percentages of both items and sub-dimensions were taken into account in these analyses.

Results

Beliefs on education for sustainable development

Beliefs on implementation of education for sustainable development. Beliefs on implementations of education for sustainable development sub-dimension contain twenty-one items. These factors assess teachers’ beliefs on education for sustainable development with respect to teaching methods, curriculum and potential benefits. The mean score of this sub-dimension was found as 4.43 over 5 with the standard deviation of .070 indicating that elementary teachers had favorable beliefs on implementation of education for sustainable development.

Table 1.

Percentage of elementary teachers' responses on beliefs on implementation of education for sustainable development dimension

	<i>SD</i> <i>1</i>	<i>D</i> <i>2</i>	<i>U</i> <i>3</i>	<i>A</i> <i>4</i>	<i>SA</i> <i>5</i>
Education for sustainable development improves students' future decision-making skills.	1.5	.5	2.6	44.8	50.5
Teaching controversial environmental, economic and developmental issues improve students' critical thinking skills	1.5	-	1.5	42.6	54.2
Allocating time on sustainable development in their lesson enriches teachers' professional repertoire.	1.0	1.0	3.1	41.7	53.1
Students can develop their own understanding of the concept when teaching about sustainable development.	1.6	1.0	3.1	52.6	41.7
Participatory learning and group work can improve students' meaningful learning.	1.6	1.0	2.6	38.5	56.3
Education for sustainable development provides knowledge, skills and values which can be utilized in daily life.	1.6	0.5	1.6	43.2	53.2
Education for sustainable development should be integrated at all levels of education.	5.2	4.7	4.7	40.6	44.8
Teachers should choose teaching topics related to their students' daily life.	2.1	2.6	2.1	50.3	42.9
In education for sustainable development, teachers should use available teaching materials in their daily life.	1.6	2.6	1.0	49.5	45.3
Private sectors, public sectors and schools should collaborate in sustainable development.	2.1	2.1	1.6	37.5	56.8
The social and cultural backgrounds of my own country should be considered when establishing content of ESD.	2.1	2.1	2.1	47.6	46.1
Education for sustainable development should be placed among the goals of every academic course.	-	5.3	15.3	46.3	33.2
Education for sustainable development should be considered by all teachers.	1.6	1.6	1.6	43.2	52.1
Students should have the right to make suggestions and decisions on matters of ESD.	1.0	2.1	8.4	50.8	37.7
Teachers should encourage students to establish a connection between their personal lives, and global environment and development issues.	2.1	1.1	2.1	43.7	51.1
News in print and visual media should be shared with students for education for sustainable development.	2.1	1.1	-	45.8	51.1
Students should participate in various projects and global and local programs for sustainability.	2.1	1.6	0.5	39.3	56.5
Role-play and debates are useful methods while learning sustainable development.	2.6	1.0	1.6	46.4	48.4
Since the content of education for sustainable development are extensive, students should determine their own subject of study.	1.6	2.6	4.7	54.2	37.0
Permitting the students openly discuss the topics is a beneficial technique for ESD.	1.6	1.0	4.7	55.5	37.2
Teachers of all fields must be informed about how they can integrate sustainable development to their own courses.	2.1	1.0	2.6	31.9	62.3

As it seen in the Table 1, elementary teachers reported effectiveness of ESD so as to improve students' future decision making abilities (95%). In addition, they also stressed that ESD enhance critical thinking ability (97%) and contribute meaningful learning (94%). These teachers also declared that students can acquire skills knowledge and values which can be integrated into their daily life (96%).

Items regarding the implementation of the education for sustainable development provided some information about teachers' beliefs on teaching process. As seen in the Table 1, teachers believe that content of the courses should be chosen considering students' daily life. Similarly, they are of the opinion that student actively participate

decision making process (89%); discussion, role playing (94%), participation national and international project (96%) and utilizing news in visual and press media (97%) for teaching are effective ways for students learning.

Lastly, teachers' responses also reflects holistic aspect of the ESD. For instance, they are of the opinion that all academic courses should include objectives related to ESD (80%), which refers integration of sustainable development different disciplines. Moreover, it is stressed that this integration should cover all educational levels from primary schools to universities (85%). Teachers' perspectives on ESD cover formal education but also informal education. They argue that both public and private sectors have responsibilities regarding implementation of sustainable development (94%).

Beliefs on limitations of education for sustainable development. Elementary teachers' beliefs on limitation of education for sustainable development were assessed with six items. Question of this sub-dimension focus on difficulties originated from complex nature of ESD. The mean score of the sub-dimension was found as 1.71 out of 5 and the standard deviation of .53, which referred that the great majority of the elementary teachers disagree or strongly disagree with the items of this belief dimension as seen with sample item in Table 2.

Table 2.

Percentage of elementary teachers' responses on beliefs on limitation of education for sustainable development

	<i>SD</i> <i>1</i>	<i>D</i> <i>2</i>	<i>U</i> <i>3</i>	<i>A</i> <i>4</i>	<i>SA</i> <i>5</i>
Education for sustainable development is an unrealistic educational approach.	63.9	30.4	2.1	2.1	1.6
The integration of sustainable development in elementary education curriculum decreases.	62.8	28.3	3.1	4.2	1.6
Teaching about sustainability is too controversial topic to be taught in elementary education.	50.0	38.0	7.8	3.1	1.0
Teachers' integration education for sustainable development in their lessons causes waste of time.	49.5	38.4	5.8	4.7	1.6
ESD issues are difficult for students to understand.	41.9	46.6	3.7	6.3	1.6
Implementation of ESD is difficult	37.7	44.5	6.8	9.9	1.0
It is difficult to integrate education for sustainable development in my own academic field.	45.3	39.6	5.7	5.7	3.6

As opposed to implementation of the education for sustainable development dimension, teachers responses concentrated on disagree and strongly disagree choices. More specifically, elementary teachers opposed to ideas that ESD is an unrealistic educational approach (93%), ESD issues are difficult for students to understand (87%) and teachers' integrating ESD in their lessons causes waste of time (87%). In addition, as provided in the Table 2, these teachers do not believe that integration of ESD in their own teaching field is challenging (85%).

Beliefs on adequacy of education for sustainable development in Turkish education system. Beliefs on adequacy of education for sustainable development in Turkish education system section includes four items measuring beliefs of elementary teachers on the sufficiency of textbook activities, curriculums and teacher trainings in terms of ESD. The mean score of 2.13 over 5 with the standard deviation of .68 shows that

elementary teachers did not believe adequacy of education for sustainable development in the Turkish education system.

Table 3.

Percentage of elementary teachers' responses on beliefs on adequacy of education for sustainable development in Turkish education system dimension

	<i>SD</i> <i>1</i>	<i>D</i> <i>2</i>	<i>U</i> <i>3</i>	<i>A</i> <i>4</i>	<i>SA</i> <i>5</i>
Education in elementary schools are sufficient to improve students' awareness about sustainable development.	20.9	41.4	15.7	12.6	9.4
Elementary teachers are adequately informed about education for sustainable development.	30.7	46.0	12.7	7.4	3.2
Education curriculums involve education for sustainable development sufficiently.	26.7	52.4	13.1	6.3	1.6
Textbooks activities are sufficient for education for sustainable development.	30.2	49.5	12.5	5.2	2.6

As seen Table 3, the majority of the elementary teachers agreed that textbooks activities are not sufficient (80%). In addition other ideas are that education curriculums do not involve ESD sufficiently (79%) and elementary teachers are not adequately informed about ESD (77%). Furthermore, participants pointed out that current education in elementary schools is not sufficient to improve students' awareness about sustainable development (63%).

Perceived Barriers towards Education for Sustainable Development

Perceived barriers towards education for sustainable development were consisted of fourteen different statements that teachers may perceive as barriers. Their perceptions towards these barriers were measured via 1-7 Likert type scale. Point one reflects that teachers hardly ever perceive these statements as barriers, while point seven reflects intensity of their perceptions as barriers. The mean scores and standard deviations of elementary teachers' responses can be seen in Table 4.

Table 4.

Elementary teachers' responses on perceived barriers towards education for sustainable development

<i>Items</i>	<i>Mean</i>	<i>SD</i>
Lack of knowledge about teaching sustainable development	4.78	1.89
Lack of knowledge about sustainable development	4.67	1.97
Lack of instructional materials	4.40	2.09
Class size too large	4.28	2.18
Lack of principle support	4.23	2.19
Lack of funding	4.14	2.13
Lack of class time	3.87	2.05
Incompatibility with curriculum	3.73	2.01
No natural environment	3.63	2.08
Safety problems	3.59	2.02
Lack of preparation time	3.31	1.88
Inconsistency among sources	3.17	1.82
ESD is not relevant to what I teach	1.97	1.47
I am not interested in ESD	1.63	1.31

As it could be detected in Table 4, elementary teachers participating in the current study reported that their interest in ESD is not a barrier ($M=1.63$). Furthermore, consistency between their teaching fields and sustainable development ($M=1.97$) are also not perceived as an obstacle towards sustainable development comparing with other items. Furthermore, the mean scores of other twelve items are very close to each other and their mean scores cluster between 3.17 and 4.78. Nevertheless, lack of the knowledge about sustainable development ($M=4.67$), lack of knowledge about teaching sustainable development ($M=4.78$) were relatively common obstacles for elementary teachers. On the other hand, it was revealed that the standard deviation of the items was relatively high, which meant teachers' responses were spread out over a large range of values. Accordingly, teachers generally had different perceptions about barriers.

Strategies towards Education for Sustainable Development

The scale consisted of teaching methods with three choices as "I have used", "I have not used" and "I have not used because it is not appropriate for ESD" were directed to explore elementary teachers' preference towards instructional strategies. As presented Table 5, relatively large percentage of the respondents declared that they have used these teaching strategies.

Table 5.

Teaching strategies towards education for sustainable development

Strategies	Percentages (%)		
	<i>I prefer</i>	<i>I do not prefer</i>	<i>I do not prefer because...</i>
Brainstorming	91.2	8.8	-
Case study	86.8	13.2	-
Independent or group projects	85.9	14.1	-
Lectures	81.8	2.0	16.3
Educational games	78.5	20.0	1.5
Computer-assisted learning activities	77.6	21.0	1.5
Role-playing	76.5	23.0	1.0
Problem-solving activities	72.1	25.9	2.0
Guided discovery	70.6	28.9	.8
Indoctrination	70.1	13.9	15.9
Field trips	68.7	28.4	.9
Simulations/ animation/ modeling	59.9	39.6	.5
Experiments	58.6	38.4	3.0

Brainstorming (91%), case study (87%) and group projects (86%) were more frequently preferred strategies teachers prefer. In addition these three, elementary teachers stressed that they have used lectures (82%), educational games (79%), computer-assisted learning activities (78%), and guided discovery (71%). On the other hand, experiment (59%) and simulation/ animation and modeling (60%) were have used less frequently. Moreover, more than fifteen percentages of the elementary teachers have not used lectures and indoctrination since these teaching methods were not appropriate for sustainable development.

Conclusions and Discussion

UNESCO (2005) clarified the characteristics of ESD such as; interdisciplinarity and holistic, values driven, critical-thinking and problem solving, multi method, participatory decision-making, applicability, and locally relevant. These characteristics are also criteria which describe a qualified teaching with respect to ESD. Considering the rationale declared by UNESCO (2005), the beliefs of Turkish elementary teachers were portrayed with respect to various characteristics of ESD.

As to interdisciplinarity and holistic perspective, ESD could be integrated into education programs from various disciplines instead of a single and specific subject. Therefore, all teachers are required to possess the responsibility to involve the issues pertinent to sustainable development in their teaching. Consultation and cooperative working among teachers and school managers are necessary. Taking into account beliefs of the elementary teachers, it is also reasonable to conclude that these teachers possess some beliefs supporting holistic perspective of ESD. In addition they did not regard ESD as inconsistent with their own teaching field. Although these teachers were teaching in different fields, they thought that they could integrate ESD into their teaching field. From another perspective, elementary teachers tend to cooperate with teachers from different discipline with respect to ESD. This situation may contribute improvement of quality of ESD in elementary schools, and, therefore, development of students' appropriate perspective towards sustainable development.

Teachers stressed that they perceived many factors such as lack of instructional materials, principle support, funding and incompatibility with curriculum as barriers for implementation of ESD. On the other hand, they believe that both implementation and integration of ESD is not difficult for them. To put other words, barriers teachers face do not obstruct their implementation of ESD. This situation indicates that teachers are able to manage and overcome these difficulties they face. Eco-school and Green Pack project may contribute teachers to cope with barriers of ESD.

Teachers' favorable beliefs on holistic and multidisciplinary nature of education for sustainable development were an unexpected considering the limitations of the Turkish education system regarding ESD. Research examining the elementary school programs, textbooks, and activities emphasized lack of appropriate perspective with respect to ESD (Kaya & Tomal, 2011; Tanriverdi, 2009; Yapıcı, 2003). That is to say, there is limited formal guidance in order to direct both teachers and students to cooperative and interdisciplinary works in the field of ESD. Thus, teachers' favorable beliefs on holistic perspective may be shaped by means of the Green Pack and Eco-School projects they participated in. For instance, considering the design of the Eco-School projects, all teachers are responsible for enhancing teaching standards with respect to ESD in a school environment. Therefore, these responsibilities may contribute to teachers' perspective towards holistic and interdisciplinary nature of ESD.

Interaction among teachers and managers in the context of ESD implementations has been considered a significant agent in integration of ESD into formal education. School managers could act as facilitators of many ESD implementations carried out in various disciplines. However, according to findings of a previous research study, one of the barriers elementary teachers faced with was the lack of support from the head of the school (Stradling, Noctor, & Baines, 1984; Winter & Firth, 2007). In the current study, it is revealed that number of the elementary teachers perceived lack of principle support as a barrier are almost equal to number of the elementary teachers did not perceive. These different perceptions may stem from the differences design of the projects elementary teachers attending. Accordingly, cooperation between teachers and manager of the school is a requirement for the Eco-School projects. Therefore, the supports of the head of the schools may not be barriers for the Eco-School coordinator teachers while it may be a barrier for the Green Pack teachers.

ESD concentrates on many values such as respect for nature, equality, tolerance, prosperity and others. It is a way to equipped students with these values and teachers should consider value aspect of the ESD while teaching. As a consequence of this process, students become aware of both their own and other people's values. Therefore, value education is important in order to grow an individual respectful to other people. In the current study, participants perceive ESD as a suitable way to improve students' value. In addition they stressed values as one of the consideration for determining content of the education for sustainable development. These beliefs indicate that teachers perceive values as both input and output of ESD. To put other words, teachers may take into account values while designing their courses, and one of the aims of their courses may be to improve students' values.

Critical thinking and problem solving skills are one of the important part of ESD. These skills contribute students' questions towards unsustainable issues and facilitate analyzing them. Therefore, Mogensen (1997) suggested exposing to students with to the issues of sustainable development in a social context in order to improve students' critical and reflective thinking abilities. Moreover, UNESCO (2005) stressed that ESD should address debates and challenges of sustainable development to improve critical thinking and problem solving abilities. Correspondingly, teachers participated in the current study believe that environmental, economic and developmental issues are useful

in order to develop student critical thinking abilities. This indicates that elementary teachers may be aware of importance of critical thinking skills and try to develop students' skills.

Considering the fact that education for sustainable development should include value-driven and interdisciplinary and holistic, there is a need for different kinds of teaching techniques and strategies in which students actively participate decision making process (UNESCO, 2005). Participatory Elementary teachers also confirmed effectiveness of participatory decision making process and active role of the students while determining topics. These beliefs described democratic classroom environments where students are active participants of the ESD. Therefore, students not only acquire knowledge but also possess skills and values, which help them become responsible citizens. However, elementary education programs are not flexible to change considering students' expectations and demands. There are fixed topics teachers should follow. Classrooms are also usually crowded in Turkey. Taking into account these factors, it is almost impossible to consider each students' opinion while designing the courses regarding ESD. Therefore, teachers' beliefs regarding the students' active participation may refer to their demand more than their actual classroom environment.

As to multi-method perspective, the common points is that strategies should be learner-centered and interactive, which help students improve their skills for sustainable development (Cotton & Winter, 2010). In a similar vein, teachers' participating the current study explained that they prefer different type of the teaching strategies and they believe that the strategies that they prefer to use are beneficial and useful with respect to students' learning. . However, all teaching techniques declared by elementary teachers did not refer to student-centered and interactive characteristics. For instance, they stressed that they prefer indoctrination and lecturing techniques which are common traditional teaching strategies. This situation may be supported that teachers tend to use different teaching strategies, they ignore role of the students in teaching process. ESD is learner-centered. Even the projects support teachers with teaching materials, it may not be sufficient for teachers to acquire appropriate perspectives on the role of learners in teaching process. Therefore, compressive and intensive programs which covers philosophy of ESD would be more effective for elementary teachers' understanding on ESD.

Elementary teacher stressed that they rarely prefer some of teaching strategies. Frequency of the experiment, modeling, simulation, animation and field trip activities are less than other techniques. Their less preference on these techniques may be a result of limited facilities in their school environment. For instance, they also stressed that they perceived lack of funding, natural environment and instructional materials as barriers for ESD. Because of these limitations, they may not utilize some of the teaching techniques which support students' effective learning. Considering this rationale, teacher should be supported with respect to materials and funding in order to extend their teaching activities on ESD.

One of the interesting point is that experimenting has the lowest percentage comparing with other teaching techniques. Experimenting is one of the effective teaching method in order to develop students' critical thinking and cognitive skills. Therefore, it is suggested as one of the effective teaching way for ESD. However, many of the participant declared that they did not utilize experiments in the context of ESD. This results may be a consequence of the teachers' views on experimenting. Experiments may be perceived with its laboratory environment or rigorous physics, chemistry or biology concepts. However, in the context of the ESD, experiments can be conducted with simple materials and content of the experiment is associated with issues students' face in their daily life. This situation indicated that elementary teachers' perception of experiment may not be

appropriate and projects and teacher training programs should help teachers' repertoire about teaching on ESD.

Although descriptive analysis of elementary teachers' responses presented useful information for ESD in the context of Turkey, the further research should shed light on the new questions. For instance, teachers' classroom activities should be observed in order to reveal whether teachers' favorable beliefs shapes their decision making in classroom environment. In addition, one of the critical question is how effective environmental education projects. Therefore, further research should manifest potential differences between teachers' beliefs considering whether or not they participate in any projects.

Reference

- Bertschy, F., Künzli, C., & Lehmann, M. (2013). Teachers' competencies for the implementation of educational offers in the field of education for sustainable development. *Sustainability*, 5(12), 5067-5080.
- Boon, H. (2011). Beliefs and education for sustainability in rural and regional Australia. *Education in Rural Australia*, 21(2009), 37-54.
- Corney, G. (2006). Education for sustainable development: An empirical study of the tensions and challenges faced by geography student teachers. *International Research in Geographical and Environmental Education*, 15(3), 224-240.
- Corney, G., & Reid, A. (2007). Student teachers' learning about subject matter and pedagogy in education for sustainable development. *Environmental Education Research*, 13(1), 33-54.
- Cotton, D. R. E., & Winter, J. (2010). It's not just bits of paper and light bulbs: A review of sustainability pedagogies and their potential for use in higher education. In P. Jones, D. Selby, & S. Sterling (Eds.), *Sustainability education: Perspectives and practices across higher education*. London: Earthscan.
- Council for Environmental Education. (1998). *Education for sustainable development in the schools sector: a report to DfEE/QCA from the Panel for Education for Sustainable Development*.
- Gayford, C. (2001). Education for Sustainability: An approach to the professional development of teachers. *European Journal of Teacher Education*, 24(3), 313-327.
- IUCN, WWF, & UNEP. (1980). *World conservation strategy*.
- Johnson, K. E. (1999). *Understanding Language Teaching: Reasoning in Action*. Canada: Heinle & Heinle Publishing Company.
- Kaya, M. F., & Tomal, N. (2011). Sosyal bilgiler dersi öğretim programının sürdürülebilir kalkınma eğitimi açısından incelenmesi [Examination of the social sciences education program in the frame of sustainable development training]. *Eğitim Bilimleri Araştırmaları Dergisi - Journal of Educational Sciences Research*, 1(2), 49-65.
- Ko, A., & Lee, J. (2003). Teachers' perceptions of teaching environmental issues within the science curriculum: A Hong Kong perspective. *Journal of Science Education and Technology*, 12(3).
- Mogensen, F. (1997). Critical thinking: A central element in developing action competence in health and environmental education. *Health Education Research*, 12(4), 429-436.
- Pajares, M. (1992). Teachers' beliefs and educational research: Cleaning up a messy construct. *Review of Educational Research*, 62(3), 307-332.
- Pehkonen, E., & Törner, G. (1996). Mathematical beliefs and different aspects of their

- meaning. *Zentralblatt für Didaktik der Mathematik [International Reviews on Mathematical Education]*, 28(4), 101-108.
- Richardson, V. (1996). The role of attitudes and beliefs in learning to teach. *The handbook of research in teacher education* (pp. 102-119). New York: Macmillan.
- Sağdıç, A., & Şahin, E. (2015). Sürdürülebilir kalkınma eğitime yönelik inançlar: Ölçek geliştirme çalışması [Beliefs on education for sustainable development: Scale development study. *Kırşehir Eğitim Fakültesi Dergisi [Journal of Kirsehir Education Faculty]*, 16(3), 161-180.
- Scoullous, M., & Malotidi, V. (2004). *Handbook on methods used in Environmental Education and Education for Sustainable Development*. Athens: MIO-ECSDE.
- Stradling, R., Noctor, M., & Baines, B. (1984). *Teaching controversial issues*. London: Edward Arnold.
- Summers, M., Childs, A., & Corney, G. (2005). Education for sustainable development in initial teacher training: issues for interdisciplinary collaboration. *Environmental Education Research*, 11(5), 623-647.
- Summers, M., Corney, G., & Childs, A. (2003). Teaching sustainable development in primary schools: An empirical study of issues for teachers. *Environmental Education Research*, 9(3), 327-346.
- Summers, M., Corney, G., & Childs, A. (2004). Student teachers' conceptions of sustainable development: the starting-points of geographers and scientists. *Educational Research*, 46(2), 163-182.
- Tanriverdi, B. (2009). Analyzing primary school curriculum in terms of sustainable environmental education. *Eğitim ve Bilim - Education and Science*, 34(151), 89-103.
- Taylor, N., Nathan, S., & Coll, R. K. (2003). Education for sustainability in regional New South Wales, Australia: An exploratory study of some teachers' perceptions. *International Research in Geographical and Environmental Education*, 12(4), 291-311.
- Thompson, A. (1984). The relationship of teachers' conceptions of mathematics and mathematics teaching to instructional practice. *Educational Studies in Mathematics*, 15(2), 105-1027.
- UNESCO. (2005). *United Nations Decade of Education for Sustainable Development 2005-2014: Draft International Implementation Scheme*.
- WCED. (1987). *Our common future*. New York: Oxford University Press.
- WHO. (2015). *World health statistics 2015*.
- Winter, C., & Firth, R. (2007). Knowledge about education for sustainable development: Four case studies of student teachers in English secondary schools. *Journal of Education for Teaching*, 33(3), 341-358.
- Yapıcı, M. (2003). Sürdürülebilir kalkınma ve eğitim. *Afyon Kocatepe Üniversitesi Sosyal Bilimler Dergisi*, 5(1), 223-229.
- Zachariou, A., & Valanides, N. (2006). Education for sustainable development: The impact of an out-door program on student teachers. *Science education international*, 17(3), 187-203.

İlköğretim Öğretmenlerinin Sürdürülebilir Kalkınma Eğitimi Bağlamında Değerlendirilmesi*

Ali SAĞDIÇ**

Orta Doğu Teknik Üniversitesi, Ankara, Türkiye

Elvan ŞAHİN

Orta Doğu Teknik Üniversitesi, Ankara, Türkiye

Özet

Bu çalışmanın amacı ilköğretim öğretmenlerinin sürdürülebilir kalkınma eğitimi açısından inanç, engel algıları, öğretim tekniği tercihlerinin tanımlanmasıdır. Çalışmanın örneklemini aynı zamanda Yeşil Kutu ve Eko-okullar isimli projelerin katılımcısı olan 211 ilköğretim öğretmeninden oluşmaktadır. Veriler, “sürdürülebilir kalkınma eğitime yönelik inançlar ölçeği”, “sürdürülebilir kalkınma eğitime yönelik engeller ölçeği” ve “sürdürülebilir kalkınma eğitimindeki teknikler ölçeği” isimli üç farklı ölçekle toplanmıştır. Ölçeklerin maddeleri, ortalama puanlar, standart sapma, frekans ve yüzde değerleri dikkate alınarak incelenmiştir. Sonuçlar, öğretmenlerin müfredat, sınıf mevcudu ve öğretim materyali eksikliğini gibi unsurları sürdürülebilir kalkınma eğitime yönelik engel olarak algıladıkları ortaya çıkarmıştır. Bu engellere rağmen, öğretmenler sürdürülebilir kalkınma eğitime yönelik olarak olumlu inançlara sahiptirler. Bu inançlar uluslararası raporlarda işaret edilen standartlarla da uyum içindedir. Bunun yanı sıra öğretmenlerin sahip oldukları inançların katıldıkları projeler aracılığı ile şekillenmiş olabileceği düşünülmüştür.

Anahtar Kelimeler: İlköğretim öğretmenleri, Sürdürülebilir kalkınma üzerine öğretim inançları, Öğretim teknikleri