

## Hardware Design of Low Cost Myoelectric Controlled Prosthetic Hand For Engineering Laboratory

Mehmet Serdar ÇELİK<sup>1\*</sup>, Cengiz TEPE<sup>1</sup>, İlyas EMİNOĞLU<sup>1</sup>

**ABSTRACT:** This study presents a low cost, two-channel, on-off type, constant speed myo-electric controlled prosthetic hand project as an educational tool for Biomedical/Control/Mechatronic Engineering. Surface Electromyogram (sEMG) signals were recorded from the muscles of flexor carpi ulnaris and extensor digitorum on the forearm. Signal conditioning of these signals is performed in the analog stages of the system, before passing it on to a microcontroller for further filtering and implementation of control. The control logic is simplified to represent the muscles as being active or inactive, resulting in a very simple on/off control based on the two signals. The on/off control signals are used to drive a myo-electric controlled prosthetic hand-powered by a hobby RC servo motor. A printed circuit board has been designed for the analog stages of the system, and a simple Arduino Microcontroller is used for the digital stages. Other commercial off-the-shelf components were used to keep the cost of the hardware and the software components as low as possible. This project was used as a teaching aid for the final year undergraduate students to demonstrate the use of simple myo-electric signal processing and control techniques.

**Keywords:** Surface EMG, prosthetic hand, signal processing, signal conditioning, biomedical education

<sup>1</sup>Mehmet Serdar ÇELİK ([Orcid ID: 0000-0003-2050-6378](#)), Cengiz TEPE ([Orcid ID: 0000-0003-4065-5207](#)), İlyas EMİNOĞLU ([Orcid ID: 0000-0003-4143-1395](#)), Ondokuz Mayıs University, Faculty of Engineering, Department of Electrical and Electronics Engineering, Samsun, Turkey

\*Corresponding Author: Mehmet Serdar ÇELİK, e-mail: mehmetserdarcelik@gmail.com

This study was produced from Cengiz TEPE's doctoral thesis.

## INTRODUCTION

sEMG is a non-invasive technique used in biomedical engineering to detect, record and process the electric activity of muscle groups. It is traditionally used for diagnostics purposes, but interest has been shown by researchers to use it to control prosthetics also (Oskoei et al., 2007; Hubbard et al., 2004; Pan et al., 2004; Akgün et al., 2013; Akirmak et al., 2017). sEMG signal is formed with the contraction of muscles. Depending on the muscle group and the position of electrodes, sEMG signal amplitude is between 20–2000  $\mu$ V. sEMG signals are preferred in the control of prosthesis because of reasons such as being non-invasive, being closer to human nature and having reliable features (Oskoei et al., 2007; Hubbard et al., 2004; Pan et al., 2004).

Generally speaking, a literature search reveals that prosthetic hand control with EMG signal consists of three main parts: EMG data acquisition, control signal generation and prosthetic hand mechanism. EMG data acquisition section consists of surface electrodes, pre-amplifier, low pass filter, high pass filter, noise reduction, rectification, amplification and ADC units. EMG data acquisition can be performed as a single channel (Hubbard et al., 2004; Akirmak et al., 2017; Cinal et al., 2016, De Moura et al., 2014, Hussain et al., 2018) or as multi-channel (Oskoei et al., 2007; Pan et al., 2004; Akgün et al., 2013; Çelik et al., 2016) by using single-use Ag / AgCl surface electrodes.

The control signal part of the prosthetic hand consists of smoothening, threshold adjustment, logic and control output sections (Asghari et al., 2007; Çelik et al., 2016; Park et al., 2003; Seguna et al., 2018; Sharmila et al., 2016; Kobayashi et al., 2010). The last part, the prosthetic hand mechanism, can be a physical/mechanical hand (Asghari et al., 2007; Çelik et al., 2016; Cinal et al., 2016; Hussain et al., 2018; Park et al., 2003; Seguna et al., 2018) or a virtual hand (Akgün et al., 2013; Çelik et al., 2016; Sharmila et al., 2016; Kobayashi et al., 2010). The control of the virtual and prosthetic hand is performed using a microcontroller or computer and data acquisition card, according to the design approach. The commercial prosthetic hand setup consists of single-channel, single threshold level and a servo motor (Suzuki et al., 2017).

When existing commercial prosthetic hands are investigated, it can be observed that opening control is made from one muscle while closing control is made from another muscle. The threshold amplitude level and gain value can be determined by two miniature potentiometers separately for each channel. In addition, a feedback circuit is employed on this commercial hand through the reference electrode (Özdemir et al., 2010).

When the literature was reviewed, no cost-effective experimental design that could represent commercial prosthetic hands opening and closing with constant speed was found. The main purpose of this study is to generate a cost-effective hardware and software substructure or experimental mechanism that can represent commercial constant speed prosthetic hand with on-off type control (Tepe et al., 2014). That mimics a commercial prosthesis in many ways.

In addition, there are studies in the literature that provide virtual prosthetic hand movement with sEMG signals obtained from the user. In one of the studies, the virtual hand designed in the MATLAB program was opened and closed with the sEMG signals obtained with a commercial sEMG amplifier (Taşar et al., 2014). In another study, the virtual hand movement designed in the Blender 3D computer graphics software was controlled by the designed two-channel sEMG amplifier (Cinal et al., 2016).

A brief summary of the literature is presented in the Table 1. In Table 1, a setup presented in the academic research, a commercial setup (Quanser, 2017) and the setup which is presented in this paper is compared.

**Table 1.** A brief summary of the literature about low-cost experimental prosthesis setups

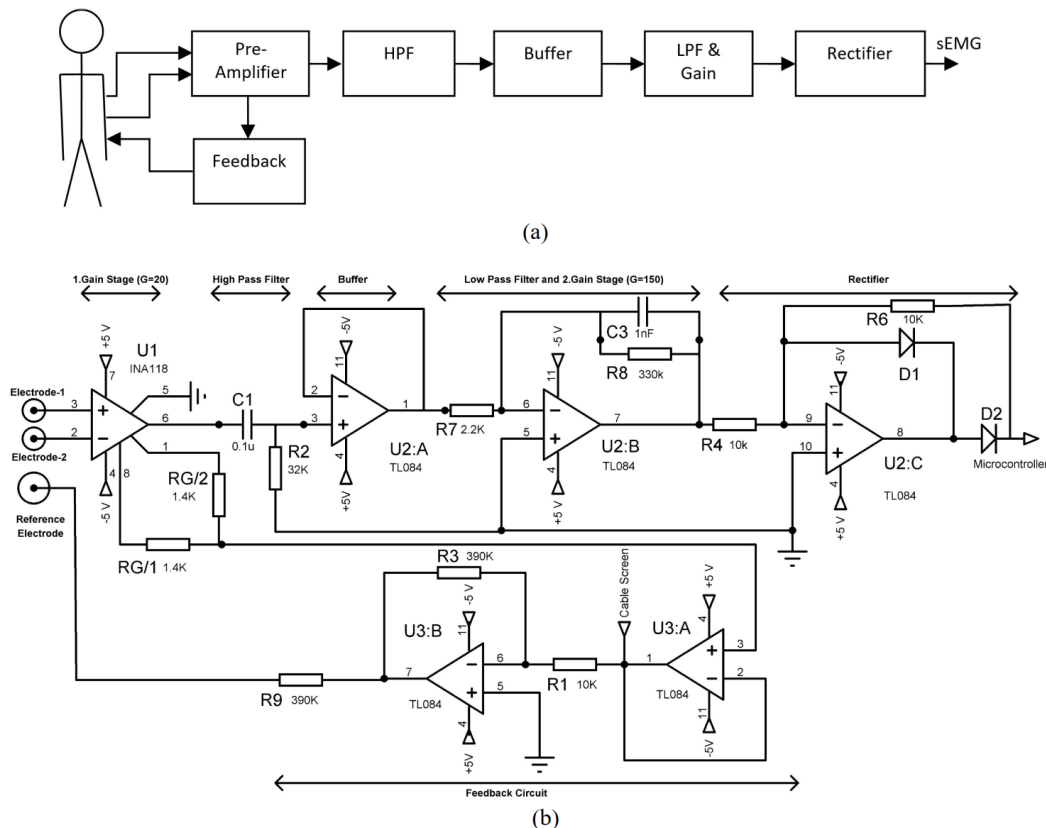
	Channel	Feedback Circuit	Adjustable Gain	Adjustable Threshold	Actuators	DoF
Pan et al., 2004	1	No	No	No	1 Servo	1
Quanser, 2017	1	Yes	N/A	N/A	1 Servo	1
This paper experimental setup	2	Yes	Yes	Yes	2 Servos	2

As for electrodes, single-use AgCl/Cl electrodes were used. Opening prosthetic hand is driven by sEMG signal taken from extensor digitorum while closing movement is driven by sEMG signal taken from flexor carpi ulnaris. Arduino Uno kit containing Atmel Atmega328 microcontroller was used. A cost-effective robot arm driven by an RC servo motor is used to represent the prosthetic hand. Secondly, how to generate a control signal is clearly described. The source code of the implementation is given in Appendix.

**MATERIALS AND METHODS**

**Experimental Setup and Data Acquisition**

The cost-effective prosthetic hand mechanism that was designed is shown in Figure 1. and Figure 2. The experiment mechanism is made up of electrodes, data cable, amplifier, filter, rectifying and feedback circuits while the hardware unit is made up of a microcontroller and prosthetic hand.

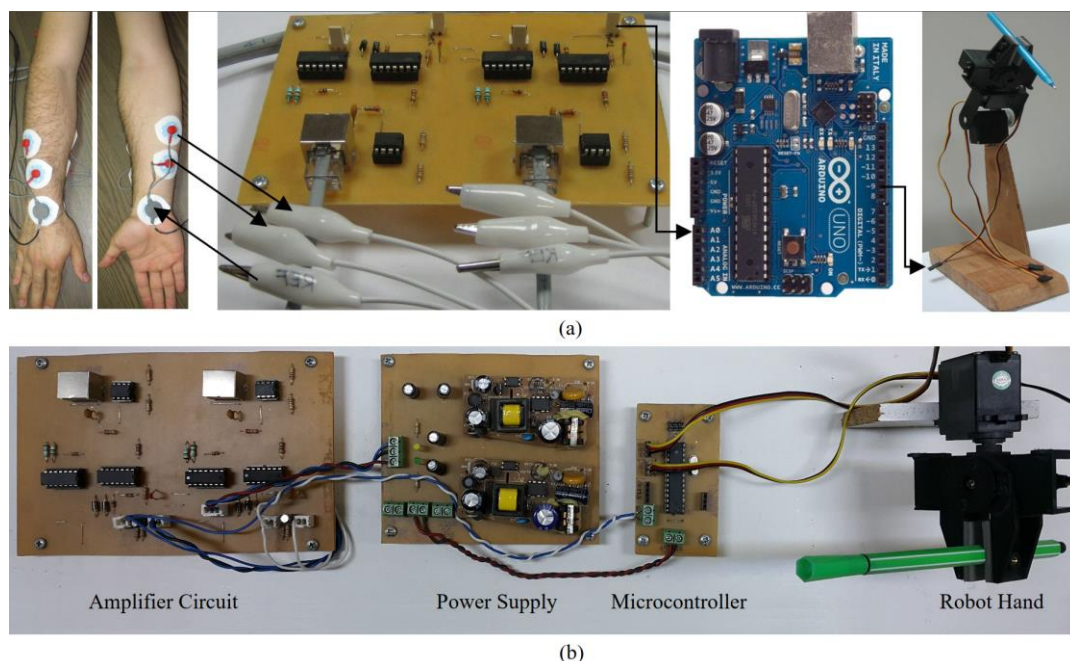


**Figure 1.** (a) Block diagram of single channel amplifier circuit with feedback, (b) two channels amplifier circuit with feedback circuit (single channel is given)

Single-use AgCl/Cl electrodes also used in clinical applications were preferred for high quality sEMG signal acquisition. Mesh-caged shield and screen cable was used to protect from undesired interference and noise without disrupting the signal quality of sEMG signal measured from electrodes

to the amplifier circuit. As can be seen from Figure 1.(a) and (b), because of its sufficient common mode rejection ratios (CMRR) and being cost-efficient, INA118 is used in the pre-amplifier unit as the instrumentation amplifier (Zecca et al., 2002) and TL084 (Texas Instruments) is used in the layers of amplifier, buffer and rectifying as the operational amplifier (Sedra et al., 1998). Instrumentation amplifiers from other manufacturers (Linear Technology, Analog Devices) can also be used.

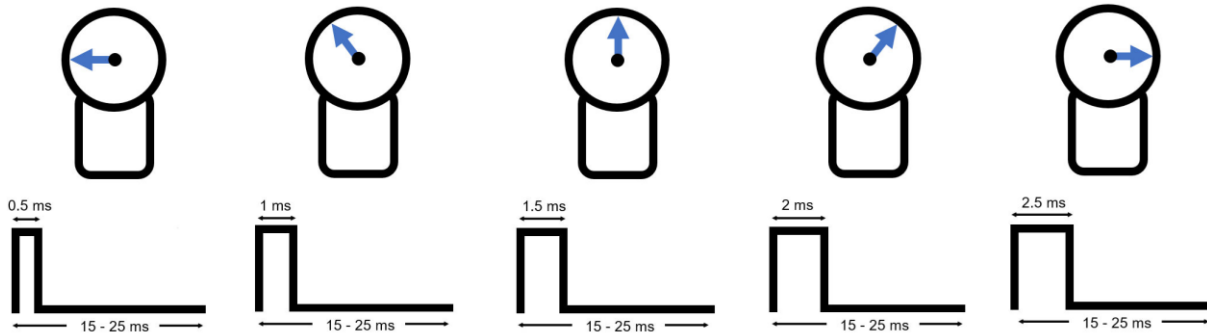
As can be seen from Figure 2.(a), sEMG signal was measured over the muscles of flexor carpi ulnaris and extensor digitorum on the forearm in two channels. The experiment board can be seen in Figure 2.(b). As can be seen from Figure 3., this signal was amplified approximately 20 times on the first gain layer (pre-amplifier). The gain of bandpass filter (BPF), which is made up of high pass (HPF) and low pass (LPF) filters designed with low power consumption, cost-effective TL084 operational amplifier (JFET type), is 150. HPF cut-off frequency is approximately 50 Hz, while LPF cut-off frequency is approximately 500 Hz. The total gain of the instrumentation amplifier and BGS is roughly  $20 \times 150 = 3000$ . This gain is enough to amplify sEMG signal and to transmit it to the microcontroller stage through the rectifier.



**Figure 2.** (a) Low cost myo-electric controlled prosthetic hand test setup, (b) prosthetic hand experimental setup

Arduino Uno kit that uses Atmel Atmega328 microcontroller is preferred for being open-source (Margolis et al., 2011), cost-efficient and having enough capacity for signal processing (sEMG data processing) and data acquisition for this application. Atmel Atmega328 has six analog-to-digital converters (ADC) inputs with a resolution of 10 bits, and a total sampling frequency of 10 kHz. The sampling frequency for each channel was chosen as 1 kHz for this project.

Servo motor is used to power the prosthetic hand for accurate position control. Servo motor is controlled by pulse width (PWM) modulation. Hitec HS-421 was chosen as the servo motor Figure 3. shows the locations of the servo motor shaft depending on the timing of pulse. At the given pulse width times interval of 0,5 - 2,5 ms, the position of the servo motor shaft moves from  $-90^\circ$  to  $+90^\circ$  clockwise.



**Figure 3.** Position of servo motor shaft according to pulse width time

### Signal Processing of sEMG and Control of Prosthetic Hand

LPF with a cut-off frequency of 2 Hz is implemented within the microcontroller. LPF transfer function in z domain is given in Equation 1 and related difference equation in discrete time is also given in Equation 2.

$$H(z) = \frac{B(z)}{A(z)} = \frac{b_1 + b_2 z^{-1} + b_3 z^{-2}}{1 + a_2 z^{-1} + a_3 z^{-2}} \quad (1)$$

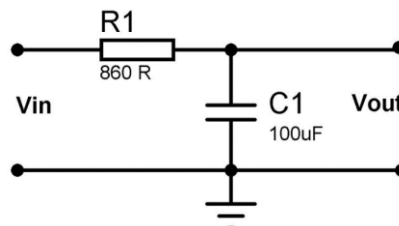
The coefficients of numerator and dominator are respectively given  $b_1=0.0983 \times 10^{-4}$ ,  $b_2=0.1965 \times 10^{-4}$ ,  $b_3=0.098 \times 10^{-4}$ ,  $a_2= -1.9911$ ,  $a_3=0.9912$ . The coefficients of Equation 1 are obtained with Matlab Butterworth filter function  $[b,a]=butter(n,Wn)$  and used in digital LPF.

$$B(k) = b_1 A(k) + b_2 A(k-1) + b_3 A(k-2) + a_2 B(k-1) + a_3 B(k-2) \quad (2)$$

Here,  $B(k)$ : System output (or filter output),  $A(k)$ : Signal to be filtered (input signal). Source code (Arduino Uno script) that implements digital LPF is given in the Appendix.

As can be seen from Figure 4., an analog LPF whose cut-off frequency of two Hz was designed to help students understand LPF better. LPF transfer process was shown in Equation 3. for  $R=830 \Omega$  and  $C = 100 \mu\text{F}$ .

$$H(j\omega) = \frac{1}{1 + j\omega RC} \quad (3)$$



**Figure 4.** Analog circuit implementation of LPF

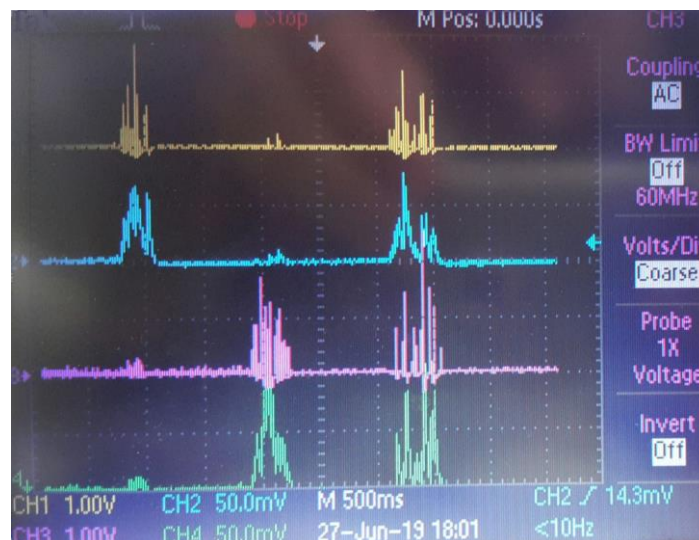
As can be seen from Figure 5., the signal envelope measured from output of LPF (given in Figure 4.) is to be shown practically through an oscilloscope. As can be seen from Figure 6., rectified sEMG signal is exposed to LPF filter and signal envelope is derived. After the envelope of sEMG signal is generated, a threshold is selected and compared with the envelope of sEMG and after the comparison, digital logic levels given in Figure 7. are obtained.



**Figure 5.** The rectified sEMG and envelope (top to bottom)

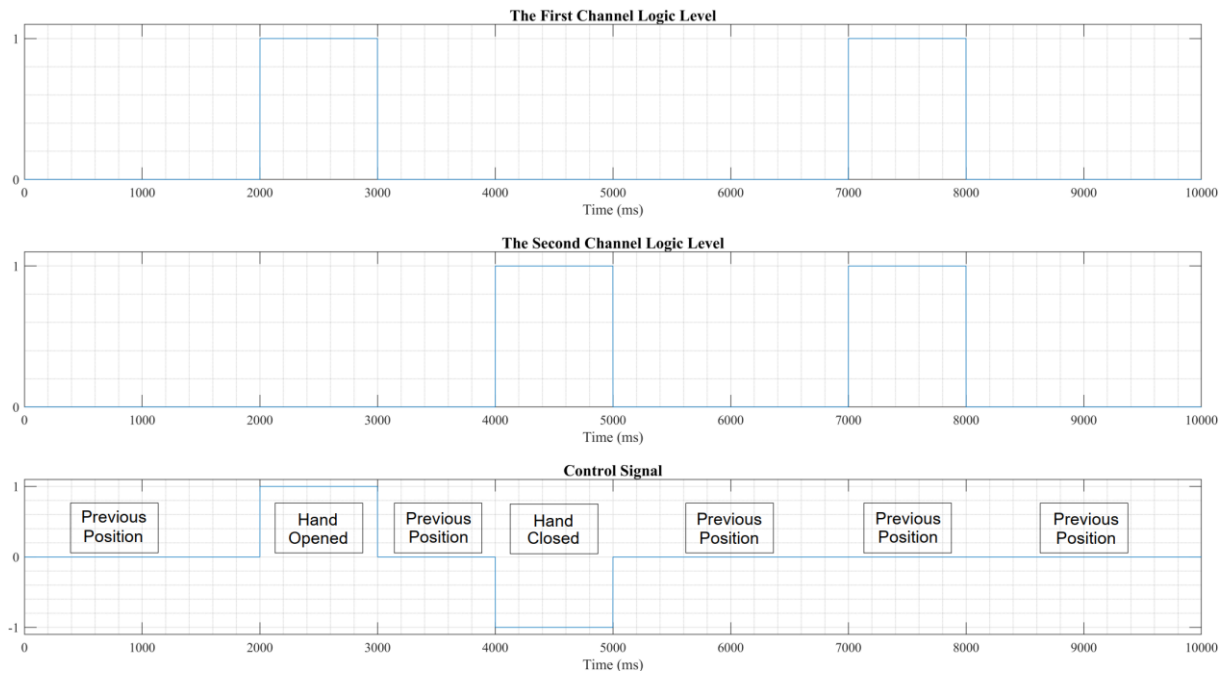
The output of the analog filter is shown in Figure 5. Digital filtering and thresholding is implemented digitally by microprocessor and obtained digital control signal is shown in Figure 7.

As can be seen in Figure 7., digital logic is "00" when flexor carpi ulnaris and extensor digitorum are during rest while digital logic is "11" when two muscles contract at the same moment and digital logic is "10" when the flexor carpi ulnaris is dominant while digital logic is "01" when extensor digitorum is dominant.

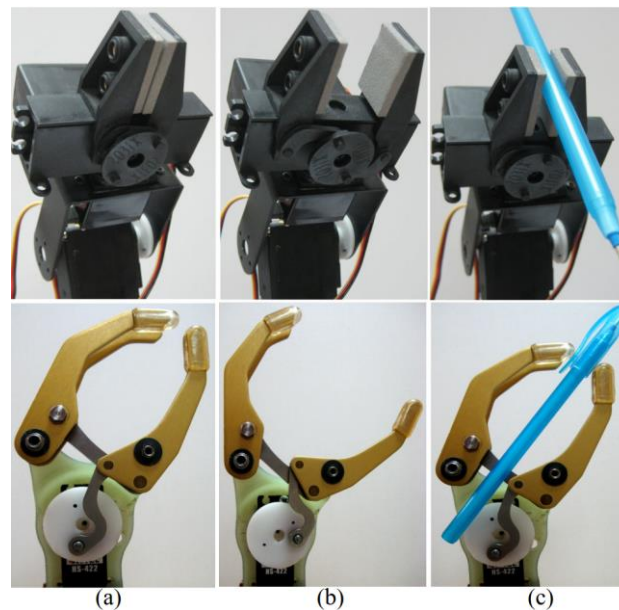


**Figure 6.** Two channels sEMG signals and their envelopes

As can be seen from Figure 7., when the first channel sEMG is "00" and second channel sEMG is "11" in terms of digital logic, it means "hold the prosthetic hand position wherever it is" and the prosthetic hand will continue to wait as open if it is already open and hand will remain closed if it is already closed. When the first and second channel sEMG is "01" in terms of logic representation, the prosthetic hand will be opened and when digital logic sEMG is "10" the hand will be closed. Figure 8.(a), (b) and (c) show the positions of the prosthetic hands as fully closed, fully open and holding a pen.



**Figure 7.** Digital representation of sEMG and control signal (on or off type)

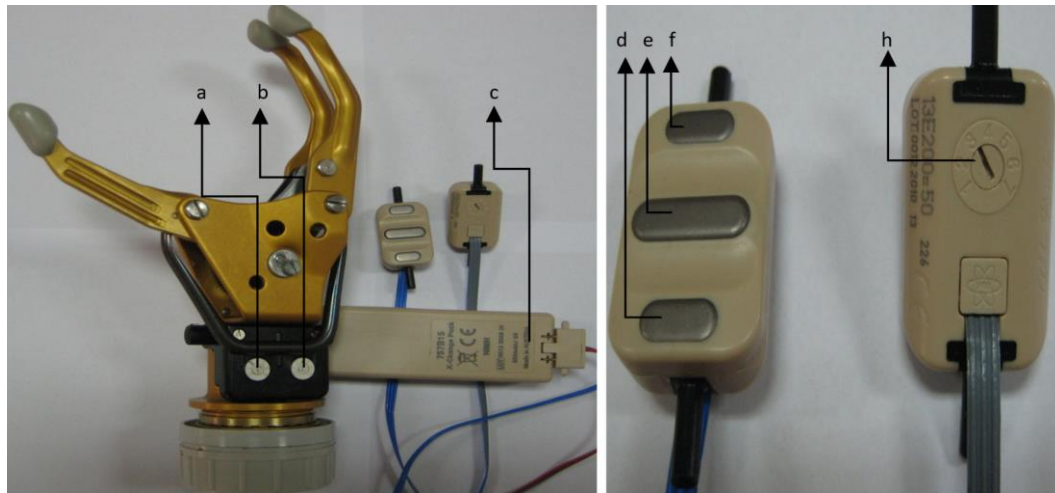


**Figure 8.** Controlled robotic hands: (a) closed, (b) open, (c) while holding the pen

## RESULTS AND DISCUSSION

In this study, an on-off type two-channel EMG controlled constant speed prosthetic hand system was designed, implemented and used in lab experiments to give students hands-on experience on the technology and techniques used. The opening prosthetic hand is controlled by sEMG signal measured from the extensor digitorum while the closing is commanded by sEMG signal recorded from flexor carpi ulnaris. In some studies (Hussain et al., 2018; Jamal et al., 2012; Jamaluddin et al., 2014; Park et al., 2003; Rahman et al., 2015) sEMG signal obtained from biceps, opening or closing of the hand was observed when biceps was at rest or when there was no sEMG signal. In other words, the prosthetic hand opens when the sEMG signal taken from the biceps exceeds a specific threshold and it closes when the sEMG signal taken from the same muscle is lower than a predefined threshold. This single-channel

control is not suitable for human nature because when human physiology is examined, the opening of the hand is controlled by the forearm extensor and closing the hand is controlled by the forearm flexor. Although there are other on-off control methods presented, a simple two-channel single threshold level method (Hubbard et al., 2004) is used in this study. Figure 9. shows a commercial prosthetic hand (De Moura et al., 2014).



**Figure 9.** Commercial prosthetic hand: (a) setting of the first channel threshold, (b) setting of the second channel threshold, (c) battery, (d) the first electrode, (e) reference electrode, (f) the second electrode, (h) amplifier gain set potentiometer

In the commercial prosthetic hand shown in Figure 9., the amplifier gain and threshold level of each channel can be customized with miniature potentiometers specifically for the end-user. The electrodes are not for single use. sEMG data can be taken from the related muscles of the user of the prosthesis through a band or a special strap. These types of electrodes are called active electrodes and are shown in Figure 9.(d), (e) and (f).

In this study, single-use, sticky Ag/AgCl electrodes, which are routinely used in clinical applications, are used. Since it is sticky, the discomfort it might cause to the skin such as irritation may seem like a disadvantage. However, during the actual experiments, it was observed that this was not an issue, since the duration for which the students used the electrodes to carry out the experiment was not long enough in duration for this to become significant.

Since sEMG signal levels are unique to individuals, threshold levels of the two-channel sEMG signals are set specifically for the end-user. In this study, this threshold level is determined for each person performing the experiments, and in the commercial hand they are determined with potentiometers which set the related channel threshold level in Figure 9.(a) and (b). In this commercial hand, amplifier gain can be adjusted with a potentiometer (hardware wise) shown in Figure 9.(h).

In this study, this amplifier gain is constant ( $G=3000$ ). As a result of the experimental studies, it has been seen that the total gain of 3000 gives enough results and the amplifier does not go into saturation. The total gain of the amplifier can be adjusted with RG in Figure 1.(b). RG determines the gain of the first stage amplifier, and it is set to 20. Each channel thresholding level is selected and implemented in the microprocessor (software-wise). Therefore, changing the overall gain (RG) of the amplifier and changing each channel thresholding level play a significant role in terms of outcome.

One of the goals of this study was to keep the cost as low as possible. sEMG signal conditioning was made from a printed circuit board that was designed and implemented using low-cost components. Data acquisition was made through cost-effective analog-to-digital converter of Atmel Atmega328 microcontroller instead of a commercial data acquisition board and C programming language was used



on this microcontroller. A physical hand was driven instead of a virtual hand in the experiments. The cost was kept low by designing the physical hand using low-cost hobby RC Servos, instead of buying a commercial prosthetic hand.

## CONCLUSION

In this study, a low cost, two channels, on-off type myoelectric controlled prosthetic hand with constant speed is designed and implemented. This study turned out to be a routine coursework project in the Electrical Engineering department. They gained the experience to process sampled signals, change the overall gain of the analog amplifier, produce control output, implement a digital filter and determine threshold levels. The digital filter was implemented, and the source code is given in Appendix. With this study, the students had the chance to observe and apply experimentally how to control output is derived from the logical representation of sEMG channels. The experimental implementation was also compared with a commercial implementation. The experimental setup can be constructed and run with a relatively low budget. Set-up represents a two-channel, on-off type prosthetic hand with a constant speed (opening and closing), and its application to classroom teaching.

## Çıkar Çatışması veya Conflict of Interest

The article authors declare that there is no conflict of interest between them.

## Yazar Katkısı veya Author's Contributions

The authors declare that they have contributed equally to the article.

## APPENDIX

/\*

Low Pass Filter:

Cut off frequency : 2 Hz

Degree : 2

Difference equation :

$$y[n] = ( 1 * x[n- 2]) + ( 2 * x[n- 1])... \\ + ( 1 * x[n- 0]) + ( -0.9823854506 * y[n- 2])... \\ + ( 1.9822289298 * y[n- 1])$$

\*/

int xv, yv;

void setup() {

// initialize serial communication at 9600 bits per second:

Serial.begin(9600);

// initial values of low pass filter constant

for (i=0;i<5;i++){

xv[i]=0;

}

for (j=0;j<5;j++){

yv[j]=0;

}

}

// the loop routine runs over and over again forever:

```

void loop() {
  // read the input on analog pin 0
  ch1 = analogRead(A0);
  // Convert the analog reading (which goes from 0 - //1023) to a voltage (0 - 5V):
  emg = ch1 * (5.0 / 1023.0);
  // Low Pass Filter
  xv(0) = xv(1);
  xv(1) = xv(2) ;
  xv(2) = emg(i) / 2.555570536e+04;
  yv(0) = yv(1) ;
  yv(1) = yv(2);
  yv(2) = xv(0) + xv(2) + 2* xv(1)...
  -0.9823854506 * yv(0) + 1.9822289298 * yv(0);
  data_AGS = yv(2);
  Serial.println(data_AGS);
}

```

## REFERENCES

- Akirmak OO, Tatar C, Altun ZG, Mishchenko Y, 2017. Design of an Accessible, Powered Myoelectrically Controlled Hand Prosthesis. *Tem Journal-Technology Education Management Informatics*, 6(3): 479-483.
- Akgün G, Alveroğlu A, Kaplanoğlu E, 2013. Sonlu Durum Makine Yöntemi ile Protez El Kontrolü. *Otomatik Kontrol Ulusal Toplantısı (TOK)*, 26-28 Eylül, Malatya, Türkiye.
- Asghari OM, Hu H, 2007. Myoelectric Control Systems - A Survey. *Biomedical Signal Processing and Control*. 2(4): 275-294.
- Cinal Ş, Çelik MS, Şahin İ, Tepe C, Eminoğlu İ, 2016. "Design of Prosthetic Hand Simulator. *Medical Technologies National Congress (TIPTEKNO)*, Antalya, October 27-29, pp:241-244.
- Çelik MS, Tepe C, Baş H, Eminoğlu İ, 2016. Multifunctional Hand Prosthesis Setup Design. *Medical Technologies National Congress (TIPTEKNO)*, Antalya, October 27-29, pp:245-248.
- Hubbard S, Heim W, 2004. Powered Upper Limb Prosthetic Practice In Paediatrics. *Powered Upper Limb Prostheses*, Muzumdar A (Ed.), pp:85-115, Springer.
- Jamal MZ, 2012. Signal Acquisition Using Surface EMG And Circuit Design Considerations For Robotic Prosthesis. *Computational Intelligence In Electromyography Analysis - A Perspective on Current Applications and Future Challenges*, Naik GK (Ed.), London.
- Jamaluddin FN, Ahmad SA Noor SBM, Hasan WZW, 2014. Flexible Bio-Signals Channels Acquisition System for ECG and EMG Application. *IEEE Student Conference on Research and Development*, Penang, December 16-17, pp:1-4.
- Kobayashi H, Sasakura T, Ishidzuka M, 2010. Development of an EMG Acquisition System of Universal Bio-Signal Interface for High-Quality Life. *The SICE Annual Conference*, Taipei, August 18-21, pp:539-542.
- Moura I, Ozelim L, Soares F, 2014. Low Cost Surface Electromyographic Signal Amplifier Based on Arduino Microcontroller. *International Journal of Electrical and Information Engineering*, 8(2):303 - 307.
- Özdemir AE Kayhan G, Usta H, Gharooni SC, Tokhi MO, Eminoğlu I, 2010. A Real-Time EMG Driven Virtual Prosthesis Hand. *International Conference on Climbing and Walking Robots and the Support Technologies for Mobile Machines (CLAWAR)*, Istanbul, September 9-11, pp:250-257.
- Pan T-T, Ping-Lin F, Chiang HK, Rong-Seng C, Jiang J-A, 2004. Mechatronic Experiments Course Design: A Myoelectric Controlled Partial-Hand Prosthesis Project. *IEEE Transactions on Education*, 47(3):348-355.
- Park J, John Park A, Mackay S, 2003. *Practical Data Acquisition For Instrumentation And Control Systems*, Newnes.
- Quanser, 2017. QNET Myoelectric Datasheet. <https://www.quanser.com/wp-content/uploads/2017/03/QNET-Myoelectric-Datasheet-v1.0.pdf> (Date of access: 3 March 2022)

- Rahman KKM, Nasor M, 2015. Multipurpose Low Cost Bio-Daq System For Real Time Biomedical Applications. International Conference on Information and Communication Technology Research (ICTRC), Birmingham, May 17-19, pp:286-289.
- Seguna C, Von Brockdorff A, Scerri J, Scicluna K, 2018. Development of a New Low-Cost EMG Monitoring System for the Classification of Finger Movement. New Generation of Circuits and Systems Conference (NGCAS), Valletta, November 20-23, pp:126-129.
- Sedra AS, Smith KC, 1998. Microelectronic Circuits, Oxford University Press, New York.
- Sharmila K, Sarath TV, Ramachandran KI, 2016. EMG Controlled Low Cost Prosthetic Arm. IEEE Distributed Computing, VLSI, Electrical Circuits and Robotics (DISCOVER), Mangalore, August 13-14, pp:169-172.
- Suzuki R, Okazaki S, Kuniya M, Muraoka Y, 2017. Low-Cost 2-Channel Electromyography Telemeter using a Personal Computer Microphone Port. International Journal of Physical Medicine&Rehabilitation, 5(386), doi:10.4172/2329-9096.1000386
- Taşar B, Kaya T, Gülten A, 2014. EMG Tabanlı El Hareketinin Analizi Aracılığı İle Robot El Simülatörünün Kontrolü. IEEE Signal Processing and Communications Applications Conference (SIU), Trabzon, April 23-25, pp:389-392.
- Tepe C, Eminoğlu İ, 2014. Düşük Maliyetli Mayo-Elektrik Denetimli Protez El Projesi: Kontrol Mühendisliği Laboratuvarı Deney Düzeneği Tasarımı. Otomatik Kontrol Ulusal Toplantısı (TOK), 11-13 Eylül 2014, Kocaeli.
- Zecca M, Micera S, Carrozza MC, Dario P, 2002. Control of Multifunctional Prosthetic Hands by Processing the Electromyographic Signal. Critical Reviews In Biomedical Engineering, 30(4-6):459-485.