

Fluid Power Control for Sun tracking of Solar panels: Modelling and Simulation

Ahmed Abu Hanieh *¹

Accepted 3rd September 2016

Abstract: This paper focuses on discussing a hydro-pneumatic hybrid (Gas/Oil), passive technique for sun tracking and orientation of solar panels, collectors and food dryers. The technique depends on utilizing the natural expansion of gases caused by temperature increase. The pressure produced by gas expansion causes a force exerted on hydraulic oil contained in the same vessel with the gas and separated from it by a diaphragm. Hydraulic fluid is used here for the stroke control because of its advantage over gas in terms of incompressibility and controllability. The exerted force caused a 50 mm displacement of the actuator which can be improved by decreasing the bore diameter of the piston and by using gases with higher expansion coefficient.

Keywords: Hydro-pneumatic; Gas/Oil; Orientation; Tracking; Mechanical Timer; Solar Energy.

1. Introduction

Solar energy has been used since a long time ago for different human needs of energy like water heating and food driers. Although other conventional sources of energy like coal and oil are widely used for their rich content of energy, but these sources are considered as a main reason for environment pollution besides to the fact that these sources are expected to end up soon. Therefore, many researchers began to investigate the possibilities of using renewable energy resources like biomass, hydro, wind and solar energy.

This paper aims at showing that there is a difference in efficiency of solar PV system between fixed installations and solar tracking ones. This system also discusses the benefit of using energy induced by solar heating as a main to operate the motion required for the tracking process.

Researches about solar passive tracking began since the early sixties where David Barton and others invented a new passive radar tracking apparatus based on reflecting the noise energy radiated by the sun [1].

Carl Wiley and Phoenix Ariz in [2] worked on a novel passive detection and ranging radar system based on detecting the noise modulated hydrogen line radiation emitted by the sun. [3] published a sun tracking system based on thermal heliotrope consists of a bimetallic helical coil that serves as the motor element, producing torque and angular displacement. In 1976, Robert Hitchcock invented an angular passive sun tracker based on using solar radiation to control the attitude of a mirror element in an array of Fresnel reflectors [4]. Solar energy can be considered the cleanest resource that depends mainly on utilizing sun power to produce clean electricity that can be used for several applications [5]. It is well known that the energy gathered by solar photovoltaic (PV) panels is very low relative to other energy resources. This implies the need to increase the efficiency of these systems by utilizing every sunny moment and concentrating the sun rays perpendicular to the surface of the PV panels for most of the daytime.

This concentration is possible by using an automatic orientation system that keeps the panels facing towards the sun as long as possible [6]. Moreover, it is worth mentioning that the solar collectors needed to heat water and even solar food driers are usually installed in places where there is no electricity source [7], [8]. Positioning collecting panels perpendicular to the sun increases their efficiency and output. Pure mechanical (fluid power) system will be discussed in this paper where hydraulic oil is actuated by the pressure of a gas enclosed in a cylindrical gas over oil vessel. The thermal expansion of the gas increases its pressure and exerts this pressure on the hydraulic oil that in turn transmits power to the actuating piston to rotate the panel.

In reference [9], the mechanical engineering group in Birzeit University has worked on a design of solar tracker system based on using two DC electric motors to drive two degrees of freedom (Altitude and the Azimuth) through mechanical gears for speed reduction in the azimuth angle and power screw for power transmission and speed reduction in the Altitude angle. Two DC motors are used to drive the two rotational degrees of freedom. The Altitude angle is driven by a power screw pinned from one side to the frame holding the panel and from the other side to a DC motor.

Other working groups worked previously on the problem of sun tracking to increase the energy efficiency. Nicolas and CEM in [10] designed a single degree of freedom tracking solar cooker consists of two rotating reflection mirrors that can rotate to track the azimuth angle of the sun but the oven is fixed with respect to the Altitude angle. Kohler et al. in [11] discussed a comparison between the fixed installation and solar tracking installation of photovoltaic panels for greened roofs. Authors offer here three tracking systems: the first system is called EGIS tracking system that rotates horizontally by 180° and vertically by 65° using tilting rotors. The second system is called ALTEC system, it rotates around a tilted North-South oriented axis with horizontal range of 54° East to 54° West and the mounting angle is set to 30°. This system uses thermo-hydraulic tracking method by using a liquid with low boiling point confined in two connected tanks. Finally, the third system is TRAXLE tracking system, this system needs electricity to drive the DC motor used for rotation which takes about 1% of the panel's surface. Panels in this system rotate by 120°. Peterson et al. in [12] have designed a two-axis solar tracker with stepper motors for the azimuth and Altitude rotational degrees of freedom. Relay circuits have been used for

¹ Department of Mechanical Engineering and Mechatronics, Birzeit University, Birzeit - Palestine

* Corresponding Author: Email: ahanieh@birzeit.edu

Note: This paper has been presented at the 3rd International Conference on Advanced Technology & Sciences (ICAT'16) held in Konya (Turkey), September 01-03, 2016.

the control purpose. Whittaker et al. in [13] discuss a new design of a solar powered polar rover which is a prototype robot called Hyperion. Hyperion means “The sun follower” in Greek language. In [14], the author Discusses a dynamic model and control design for a 76×76 m square sail employing spin stabilization, reaction wheel, a two-axis gimbaled control boom and a sail panel translation and rotation system. The US Patent of Murphy and Crowley in [15] discusses an optimal solar tracking system for a spacecraft to compensate for the undesired disturbances using a time modulated solar tracking scheme which increases the power efficiency without influencing the transmitted torque. Khan and Ali in [16] discuss an automatic sun tracking system with six functional sensors, stepper motors and microcontroller control system for automatic orientation of the solar panel towards the sun. The microcontroller stops all operations at night and repositions the panel towards east to be ready for the next morning. In [17], Martinez demonstrates a patent based on the invention of a bidirectional solar tracker moved by two hydraulic actuators.

Section 2 in this article discusses the mechanical design of the installation used to hold and move the solar panels. The Gas over oil fluid power tracking system is tackled in section 3. Section 4 shows the kinematic analysis of the system while the dynamic calculations and governing equations are show in section 5. Section 6 depicts the simulation results based on the analytical model and the conclusions and future works are shown in section 7.

2. Mechanical Design

BZU test setup used for the purpose of sun tracking at Birzeit University, the systems is shown in Fig. 1. The 70 kilograms test rig consists of a 1.5×1.5 m² Photovoltaic (PV) panels fixed on a steel frame. The frame is allowed to rotate in two degrees of freedom; the first is rotational in the horizontal plane and called Azimuth angle (θ_A) and the second is the angle of elevation of the panel in the vertical plane and called Altitude angle (θ_z) taken from the Zenith of the sun. In this project, the Altitude angle is fixed to 45° and the control is used to move the Azimuth angle only. It is worth mentioning that changing the Altitude angle leads to very small improvement in the performance while the efficiency is very much influenced by changing the Azimuth angle θ_A [16]. Although this project is targeted to solar collectors and food dryers but PV panels were used here to facilitate the measurement of collected energy influenced by sun tracking.

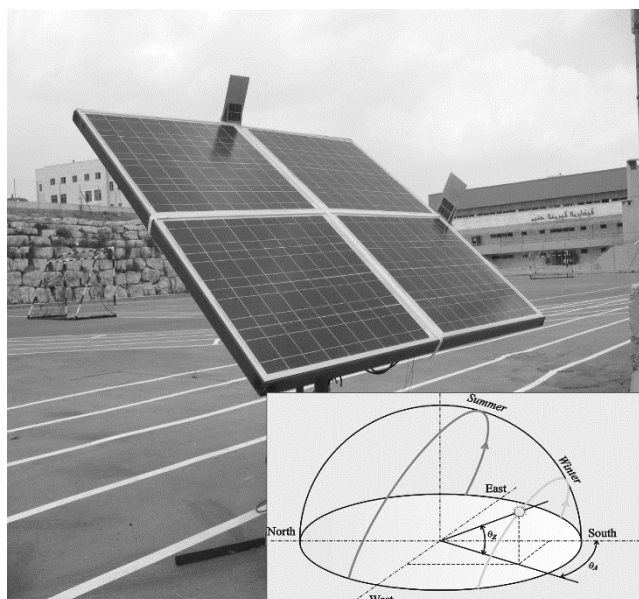

Figure 1. BZU sun tracking system

3. Fluid Power Tracking System

Fig. 2 shows a CAD design of the whole tracking system. The setup is supplied with two Gas/Oil tanks, one at each side. Every tank is located axially at the focal central axis of a parabolic concentration galvanized steel plate. The Gas/Oil tanks supply pressurized oil (SAE 10) to the hydraulic system used for the tracking piston via an accumulator and several directional control valves. The implemented gas here is Nitrogen for his good safety and expansion factor. A mechanical timer connected to the end of the hydraulic piston is used for timing the piston extension during the day in an open-loop control technique. The timer is based on spring loaded geared design mechanical system that does not need an external power supply to operate.

The parabolic concentrators shown in Fig. 3 are made of galvanized steel sheets rolled in a parabolic shape. These concentrators aim at concentrating the solar energy at the focal axis at which the Gas/Oil tanks are installed.

The fluid power circuit applied to control the position of the solar panel is shown in Fig. 4. The two tanks T_1 and T_2 represent the two Gas/Oil tanks where the expanding gas (Nitrogen) forms 90% of the tank's volume while the rest 10% contains hydraulic oil (SAE 10). This ratio was selected to increase the area of gas exposed to sun rays as much as possible to increase the influence of heat transfer. These tanks have an initial volume before expansion equals to 0.01124 m³, initial pressure equals to 5 bar and initial temperature equals to 30° . Solar concentrators can heat the system from 30° to 70° and this leads to increase the volume to 0.011349 m³. The gas pressure exerts a similar pressure on the neighbour oil separated from the gas by a diaphragm making Gas/Oil effect capable of exerting a force of 600 N at the piston acting on the panel. The Gas/Oil tanks are painted in black and each is installed at the focal central axis of a reflecting parabolic steel sheet. The parabolic reflector aims at concentrating the solar rays towards their focal centre increasing the energy transferred to the tanks.

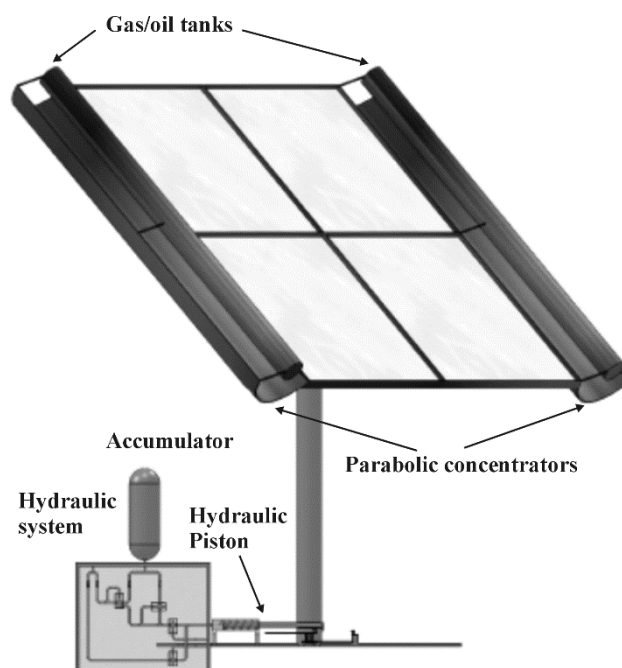

Figure 2. CAD design of the fluid power controlled system

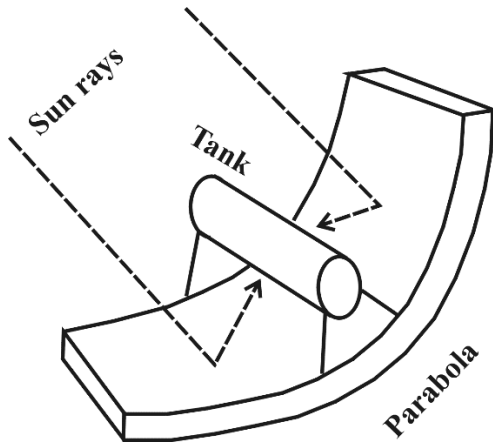

Figure 3. Parabolic solar concentrators

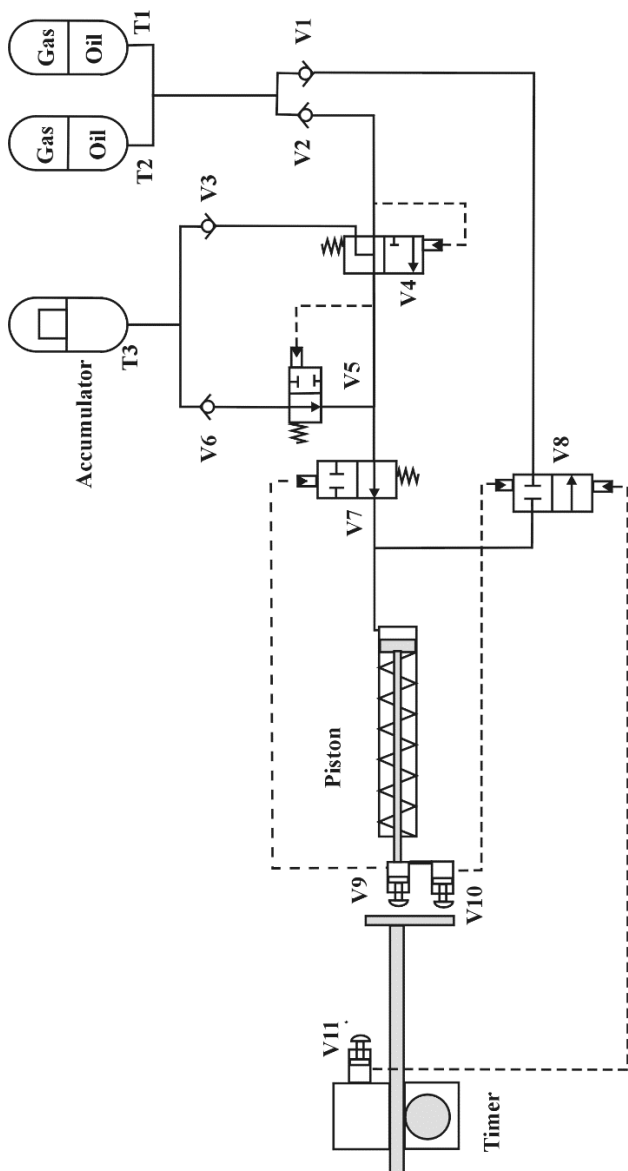

Figure 4. Fluid power control symbolic circuit

The pressurized oil leaves the two tanks at the same time to find the non-return check valve V_1 closed forcing oil to pass through the inverted non return valve V_2 . While the day time is equal or earlier than the reading of the timer clock, valves V_4 and V_7 stay open allowing the compressed oil to exert force on the single acting piston P extending it to the required position. During this

stage, valve V_5 stays closed by the pilot pressure coming from the main line. The mechanical timer takes its reading from the position of the piston, when this reaches the real clock time, the timer closes valve V_7 preventing oil from passing to the actuator. When V_7 is closed, oil passes to the accumulator T_3 via the non-return valve V_3 to accumulate and store compressed oil as a potential energy to be used in later stages.

After a few cloudy hours, pressure is reduced in the main line causing valve V_5 to move to the spring loaded position (open position). The oil of the accumulator is released through non return valve V_6 to overcome the required position of the piston. Limit switch V_9 is used to change the position of valve V_7 to stop the oil flow when the piston reaches the real clock time. Valve V_{10} is used to keep the valve V_8 closed during the whole day to prevent returning the oil back through the return line.

At the end of the day, the mechanical timer reaches its final position and valve V_{11} opens valve V_8 allowing the oil existing in the piston to return back to the tanks T_1 and T_2 through the non-return valve V_1 . The single acting piston is retracted back by the effect of its loading spring allowing the panel to return to its original position facing to the East waiting for the sun rise of the next morning.

4. Kinematic Calculations

Schematic drawing in Fig. 1 shows a typical behaviour for the sun path in December (winter) and June (summer). The rotational angle of the tracking system in the vertical plane (θ_z) can be calculated from the following equation [18]:

$$\sin \theta_z = \sin \phi \cdot \sin \delta + \cos \phi \cdot \cos \delta \cdot \cos \omega \quad (1)$$

Where θ_z is the Altitude angle of the system ($\theta_z = 90^\circ - \text{zenith angle of the sun}$), ϕ is the Latitude in degrees, ω is the hour angle ($15^\circ / \text{hour}$), where $\omega = 0$ at local noon. δ is the solar declination, where δ is calculated from Cooper's equation:

$$\delta = 23.45 \cdot \sin \left[\frac{360}{365} (284 + N) \right] \quad (2)$$

Here, N is the day of the year ($1 - 365$), $N = 1$ on the 1st of January.

The rotational angle of the system in the horizontal plane (θ_A) is calculated from the equation:

$$\sin \theta_A = \frac{\cos \delta \cdot \sin \omega}{\cos \theta_z} \quad (3)$$

Where θ_A is the Azimuth angle of the system [5].

The stroke of the actuator y is related proportionally to the pressure in the system multiplied by the area as will be seen in the next section. This relation is influenced by the dynamics of the system that behave like a second order low-pass filter. As the maximum extension obtained does not exceed 50 mm, this displacement is magnified by connecting the tip of the actuator to the panel close to the centre of rotation. This in turn increases the torque which does not make a big problem for the system where the load is much smaller than the induced pressure.

5. Dynamic Calculations

Looking at the fluid power circuit shown in Fig. 4, the pilot operated proportional hydraulic control valve can be modelled by looking mainly at the flow equation that reads, [19], [20]:

$$q = C_d \alpha x \sqrt{\frac{2}{\rho} \Delta P} \quad (4)$$

Where q is the fluid flow rate through the valve (m^3/s), ΔP is the pressure Difference across the valve (Pa), C_d represents the flow discharge coefficient ($m^3/N.s$), α is the area gradient (width) of the orifice (port) of the valve (m), ρ is the density of the oil (kg/m^3), x is the distance travelled by the spool of the valve to open the orifice (m). The pressure drop across the valve has a negligible influence, which means that ΔP is considered constant. This leads to the following relation.

$$q = K_v x \quad (5)$$

Where

$$K_v = C_d \alpha \sqrt{\frac{2}{\rho} \Delta P} \quad (6)$$

K_v is the valve flow constant. The single acting hydraulic cylinder can be modelled from two sides. The first is by finding the flow rate coming into the cylinder and the second is by making dynamic force equilibrium on the piston. Taking into account the continuity equation to calculate the oil flow rate flowing into the hydraulic actuator, the total flow rate Q coming into cylinder reads [21]:

Total flow rate = Flow inside cylinder + Flow loss due to Compressibility + Flow loss due to leakage

$$Q = A \dot{y} + \frac{V}{\beta} \dot{P} + \lambda P \quad (7)$$

Where Q is the total flow rate coming into cylinder, $A \dot{y}$ is the

flow rate inside cylinder causing piston speed, $(V/\beta) \dot{P}$ is the flow rate loss due to fluid compressibility in the actuator, λP is the flow rate loss due to fluid leakage in the actuator, β is the Bulk modulus of the used oil (N/m^2), λ is the leakage coefficient ($m^4.s/kg$), A is the cross sectional area of cylinder (m^2), V is the

volume of fluid in cylinder (m^3) and \dot{y} is the speed of piston advance (m/s).

The dynamics of the hydraulic piston are governed by a second order differential equation if we neglect the nonlinearities coming from the fluid flow and friction [22].

Newton's second law can be applied to the actuator to find the dynamic force equilibrium:

$$PA - k_s y = m \ddot{y} + C \dot{y} + ky \quad (8)$$

Or calculating the transfer function between the oil pressure as an input and the piston displacement as an output

$$\frac{y}{P} = \frac{A}{ms^2 y + Csy + (k + k_s)y} \quad (9)$$

Where P is the pressure inside the cylinder, A is the cross sectional area of the cylinder, C is the viscous damping coefficient, k is the total stiffness of preloading spring and the

hydraulic stiffness of the oil, y , \dot{y} , \ddot{y} are the displacement, velocity and acceleration of the piston respectively, $k_s y$ is the

preloading force of the spring, m Effective mass of the moving piston and panel with frame.

The effective mass m can be determined from the mass moment of inertia of the load J and the distance (L) between the centre of gravity and the centre of rotation of the load ($m = J/L^2$). The gas/oil tank in the case of isothermal change of state can be governed by the combined gas law as follows

$$\frac{P_1 V_1}{T_1} = \frac{P_2 V_2}{T_2} \quad (10)$$

Or calculating P_2

$$P_2 = \left(\frac{V_1}{V_2} \right) \left(\frac{T_2}{T_1} \right) P_1 \quad (11)$$

Where, P_1, V_1, T_1 Initial Pressure, Volume and Temperature before gas expansion. P_2, V_2, T_2 Final Pressure, Volume and Temperature after gas expansion

6. Simulation Results

The hydro-pneumatic orientation control system is modeled using the integrated definition block diagram shown in Fig. 5. The main input to this model is the pressure of fluid in the system caused by solar heating of the storage tanks. This pressure is constant neglecting the friction losses in the pipes and hoses. Multiplying the pressure by the area of the piston cylinder conforms the hydraulic force acting on the piston. This hydraulic force is split into three main force components; the force of spring preloading the single acting piston, the force of the viscous damping in fluid and the inertia force of the mechanical load. The displacement of the piston y is the main output of the model. The fluid flow Q is another output. The flow rate is the sum of three quantities: flow due to leakage, flow due to compressibility and net flow in the piston. The left hand circuit shows the hydraulic components while the right hand side shows the model of the mechanical components.

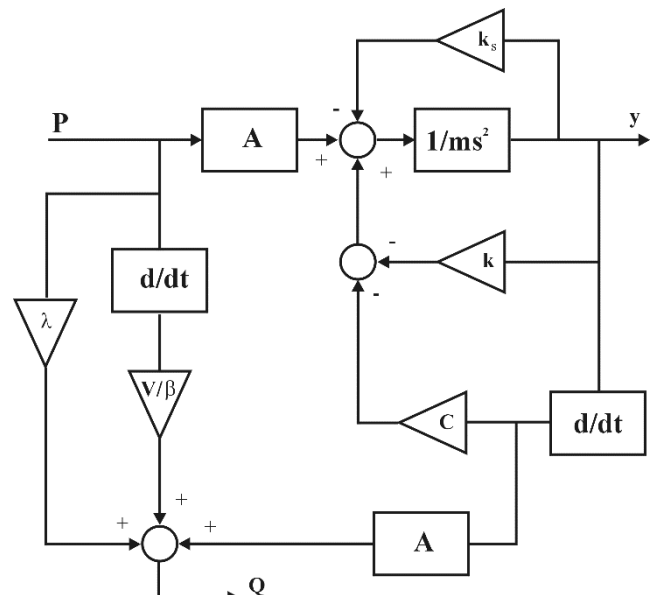

Figure 5. Block diagram for the Hydro-pneumatic control system

Fig. 6 shows the relation between temperature and time taken from simulation results. It is clear that the temperature increase from 30° to 70° in 100 minutes. This increase is caused by concentrating sun rays on the storage tanks which increases the volume of fluid keeping constant pressure in the system. The

block model shown in Fig. 5 is simulated using MATLAB software. The stroke travelled by the piston is shown in Fig. 7. This stroke increases from rest to 50 mm in 100 minutes. Table 1 shows the numerical results for the temperature and stroke taken from the MATLAB simulation results.

Table 1. Temperature and stroke vs. time from simulation results

| Time (min) | Temperature (C) | Stroke (m) |
|------------|-----------------|------------|
| 0 | 30 | 0 |
| 10 | 34 | 0.0049 |
| 20 | 38 | 0.0098 |
| 30 | 42 | 0.0147 |
| 40 | 46 | 0.0196 |
| 50 | 50 | 0.0244 |
| 60 | 54 | 0.0293 |
| 70 | 58 | 0.0342 |
| 80 | 62 | 0.0391 |
| 90 | 66 | 0.044 |
| 100 | 70 | 0.0489 |

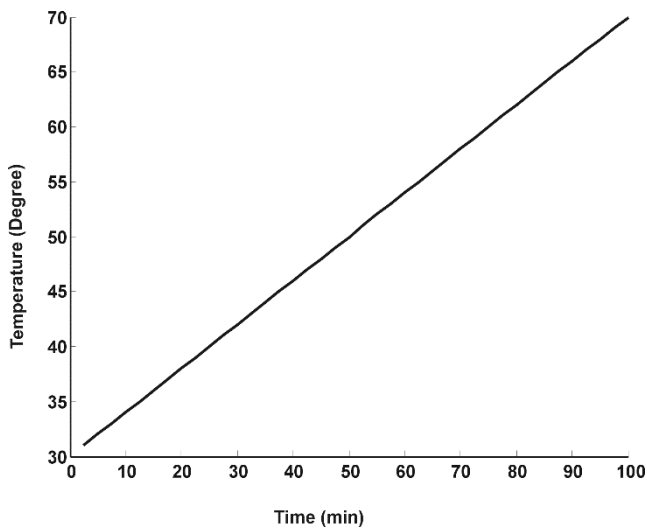

Figure 6. Temperature in the tanks versus time

The dynamics of the system are simulated and studied by calculating the frequency response function between the pressure as an input and the piston stroke as an output. This Bode plot shown in Fig. 8 expresses that the piston stroke remains constant relative to the system pressure at low frequency. This means that the piston responds faithfully to the slewing motion of the fluid while it remains at low level at high frequency when rapid changes occur in the fluid pressure. This protects the system from the risk of undesired oscillations and vibrations that may lead the system to failure if their frequency is close to the natural resonance of the system. To avoid possible influence of these oscillations, elastomers are added to the joints and pivots of the system to act as passive dampers that absorb and reduce the overshoot of these vibrations.

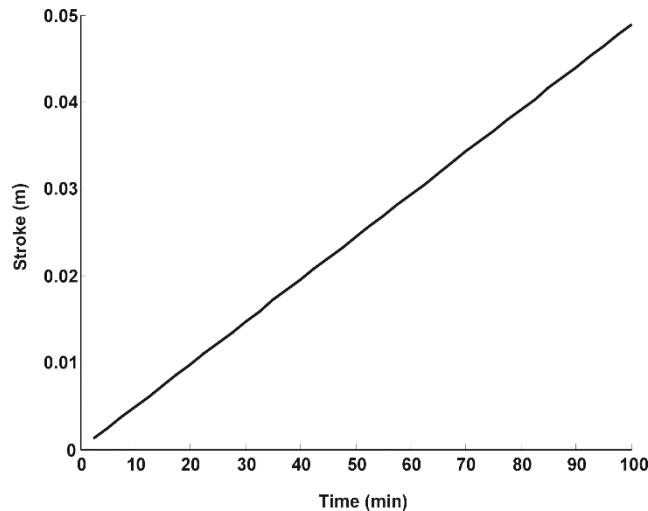

Figure 7. Piston stroke versus time

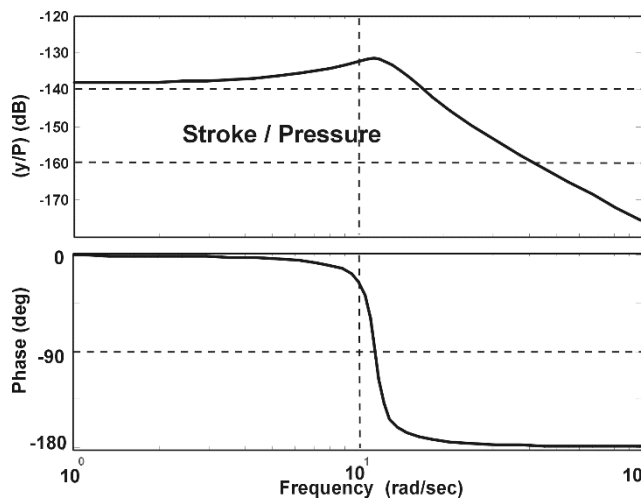

Figure 8. Transfer function between piston stroke and pressure

7. Conclusions

It is noticed from the discussion shown in this paper that passive techniques can be used efficiently in tracking sun for solar collectors and food dryers in places where there is no electricity. Even it can be used for tracking of solar PV panels, although electricity exists but using passive ways can save electricity produced by the panels to be used for other purposes. The most difficult problem faced here are the nonlinearity in the piston, bearings and moving parts of the system. These nonlinearities need to be included in a more complicated model for better prediction. The other restriction is the small amount of expansion reached because of using Nitrogen as an expansion gas. Using other gases like Methanol or Acetone can give higher expansion and better results but it exposes the system and people to the risk of dealing with inflammable gases. High temperatures can be reached by using materials like stainless steel or glass mirrors for the fabrication of parabolic concentrators. The maximum reached stroke can be increased also by changing the bore diameter of the used hydraulic piston and hoses but this will be accompanied by higher losses in pressure due to higher friction in piping system.

Acknowledgements

The author would like to thank the research fund unit in the Academic affairs of Birzeit University for their support to this research.

References

- [1] Barton, D. Hadonnfield and Rose, W. Passive Radar Tracking Apparatus, US Patent no. (3,196,433) , July 1965.
- [2] Wiley, C. and Ariz, P. Passive Detection and Ranging System, US Patent no. (3,171,126) , February 1965.
- [3] Fairbank, J. and Morse, F. Passive Solar Array Orientation device for terrestrial application, *Journal of Solar Energy*, 14(1), 67-70, December 1972.
- [4] Hitchcock, R. Passive Solar Tracking for steerable Fresnel elements, US Patent no. (3, 986,021), October 1976.
- [5] McVeigh, J. *Sun Power*, 2nd ed., Pergamon Press, 1983.
- [6] Mukind, P. *Wind and Solar Power Systems*, New York, Merchant Marine Academy Kings Point, 1999.
- [7] Minister of Natural Resources of Canada, *Clean Energy Project Analysis*, 2005.
- [8] Palestinian Ministry of Local Government, *Guidelines for Energy Efficient Building Design*, Bailasan, 2004.
- [9] Abu Hanieh, A. Orientation of Solar Photovoltaic Panels in Desert Regions, *International Review of Automatic Control (IREACO)*, Praise Worthy Prize, 1(3), pp 347-354, September 2008.
- [10] Nicholas, C. and CEM, P. *The tracking Solar Cooker*, Tucson, Arizona, 1993.
- [11] Kohler, M. Shmidt, M. Laar, M. Wachsmann, U. and Krauter, S. Photovoltaic Panels on Greened Roofs, Positive Integration Between Two Elements of Sustainable Architecture, R10 02 – World Climate & Energy Event, pp6-11, January 2002.
- [12] Peterson, T. Rice, J. and Valane, J. *Solar Tracker*, Final Project in Cornell University, ECE 476, Spring 2005.
- [13] Whittaker, W. Kantor, G. Shamah, B. and Wettergreen, D. *Sun-Synchronous Planetary Exploration*, AIAA, 2000.
- [14] Bong Wie, *Dynamic Modeling and Attitude Control of Solar Sail Spacecraft*, JPL Contract, NASA Solar Sail Technology Working Group, January 2002.
- [15] Murphy, J. and Crowly, R. *Optimal Solar Tracking System*, October, US Patent no. (5,816,540) , 1998.
- [16] Khan, M. and Ali, R. *Automatic Sun Tracking System*, Air University, Islamabad, Pkistan, 2003.
- [17] Martinez, C. *Bidirectional Solar Tracker*, US Patent no. (2010/0095955) , April, 2010.
- [18] Sorensen, H. *Energy Conversion Systems*, John Wiley & Sons, 1983.
- [19] Yuan, Q. and Li, P. Using Steady Flow Force for Unstable Valve Design, Modeling and Experiments, *Journal of Dynamic Systems, Measurement and Control*, 127, pp 451-462, September, 2005.
- [20] He, Q. Hao, P. and Zhang, D. Modeling and Parameter Estimation for Hydraulic System of Excavator's Arm, *J. Cent. South Univ. Technol. Springer*, 15, pp 382-386, 2008.
- [21] Abu Hanieh, A. *Fluid Power Control, Hydraulics and Pneumatics*, Cambridge International Science Publishers, 2012.
- [22] Pinches, M. and Ashby, J. *Power Hydraulics*, Prentice Hall, 1988.