



Review Article





Journal of Innovative Healthcare Practices (JOINIHP) 3(1), 1-7, 2022

Received: 11-May-2022 Accepted: 20-Jun-2022



SAKARYA UNIVERSITY
OF APPLIED SCIENCES

Wearable Modular Chest Tube Carrying Apparatus for Lower Extremities

Sinan KÖSE¹ , Demet BAL^{2*} , Tuğba ÖZCAN³ , Kevser KASAP⁴ 

¹ Department of Machinery and Metal Technologies, Organized Industrial Zone Vocational School, Tarsus University, Turkey. sinankose@tarsus.edu.tr

² Department of Nursing, Faculty of Health Sciences, Karadeniz Technical University, Turkey. demetk@windowslive.com

³ Department of Nursing, Faculty of Health Sciences, Karadeniz Technical University, Turkey. ozcan1tugba@gmail.com

⁴ Department of Nursing, Institute of Health Sciences, Kafkas University, Turkey. k.kevser098@gmail.com

ABSTRACT

Chest tube application is performed in the treatment of lung diseases such as pneumothorax, hemothorax, pleural effusion and empyema, and in the drainage of blood and air accumulated in the pleural cavity after thoracic surgery. In chest tube application using a closed underwater drainage system, it is necessary to use the chest tube correctly in order to realize one-way drainage in the lungs, to ensure the continuity of effective ventilation and closed drainage. During the mobilization process after chest tube application, the patient carries the drainage bottle by holding it from the carrying strap at the top of the bottle, putting the bottle in a bag and tying it to the IV pole. During transportation, the drainage bottle is overturned and damaged and the chest tube may come off due to reasons such as rupture of the strap, rupture of the bag, and the fall of the IV pole. Due to the displacement of the chest tube, air fills the pleural space and the lungs lose their function due to the increased positive pressure. In addition, it causes complications such as bleeding, pain and infection caused by trauma in the incision area and prolong the patient's discharge period. In this study, it was aimed to design a modular chest tube carrying device that can be worn on the lower extremities to minimize the problems that may occur in the transportation of the chest tube, which is used to drain blood and air in patients who have undergone thoracic surgery. The developed chest tube carrying device design consists of a physical structure that can be worn on the lower extremities of the patient and consists of the chest tube carrying apparatus body where different sizes of chest tubes are positioned, the unit cover that prevents the chest tube from being dislodged, and the leg connection strap that connects the chest tube body to the lower extremities. The chest tube carrying apparatus body can be locked by closing with the unit cover, thus ensuring the safety of the chest tube. The chest tube carrying apparatus can be fixed to the patient's leg by adjusting the connecting straps according to the size of the lower extremity of the patient. In addition, the spring mechanism located at the bottom of the chest tube carrying apparatus body softens the hard movements that may occur during the mobilization of the patient in order not to damage the chest tube. As a result, the use of a wearable modular chest tube carrying device for the lower extremities aims to prevent complications caused by the fall of the chest drainage bottle during transportation. In this way, patients with chest tube can be mobilized after chest tube application, while performing the chest tube more safely and comfortably.

Keywords: Wearable technology, thoracic surgery, chest tube, modular, carrying device

* Corresponding Author's email: demetk@windowslive.com

Alt Ekstremitelere Giyilebilir Modüler Göğüs Tüpü Taşıma Aparatı

ÖZ

Pnömotoraks, hemotoraks, plevral efüzyon ve ampiyem gibi akciğer hastalıklarının tedavisinde ve göğüs cerrahisi sonrası plevral boşlukta biriken kan ve havanın drenajının gerçekleştirilmesinde göğüs tüpü uygulaması yapılmaktadır. Kapalı sualtı drenaj sistemi kullanılan göğüs tüpü uygulamasında, akciğerlerdeki tek yönlü drenajın gerçekleştirilmesi, etkili ventilasyonun ve kapalı drenajın devamlılığının sağlanması için göğüs tüpünün doğru bir şekilde kullanılması gerekmektedir. Göğüs tüpü uygulamasından sonraki mobilizasyon sürecinde hasta drenaj şişesini üst kısımdaki taşıma askısından tutarak, şişeyi bir poşetin içerisine koyarak ve serum askısına bağlayarak taşımaktadır. Taşıma sırasında askının kopması, poşetin yırtılması, serum askılığının düşmesi gibi nedenlerden ötürü drenaj şişesi devrilip zarar görmekte ve göğüs tüpü yerinden çıkabilmektedir. Göğüs tüpünün yerinden çıkmasına bağlı olarak plevral boşluğa hava dolmakta ve artan pozitif basınç nedeniyle akciğerler işlevini kaybetmektedir. Ayrıca insizyon bölgesinde travmaya bağlı olarak oluşan kanama, ağrı ve enfeksiyon gibi komplikasyonların görülmesine ve hastanın taburculuk süresinin uzamasına neden olmaktadır. Bu çalışma ile akciğer hastalıklarının tedavisinde ve göğüs cerrahisi geçiren hastalarda kan ve havanın drenajını sağlamak amacıyla kullanılan göğüs tüpünün taşınmasında oluşabilecek sorunları aşgari düzeye indirgeyecek alt ekstremitelere giyilebilir modüler göğüs tüpü taşıma aparatının tasarlanması amaçlanmıştır. Geliştirilen göğüs tüpü taşıma aparatı tasarımı, hastanın alt ekstremitelerine giyilebilecek fiziksel yapıda olup farklı boyutlardaki göğüs tüplerinin konumlandığı göğüs tüpü taşıma aparatı gövdesi, göğüs tüpünün yerinden çıkmasını önleyen ünite kapağı ve göğüs tüpü gövdesinin alt ekstremitelere bağlantısını sağlayan bacak bağlantı kayışından oluşmaktadır. Göğüs tüpü taşıma aparatı gövdesi, ünite kapağı ile kapatılarak kilitlenebilmekte ve böylece göğüs tüpünün emniyeti sağlanmaktadır. Hastanın alt ekstremitte boyutuna göre bağlantı kayışları ayarlanarak göğüs tüpü taşıma aparatı hastanın bacağına sabitlenebilmektedir. Ayrıca göğüs tüpü taşıma aparatı gövdesinin alt kısmında bulunan yaylı mekanizma, hastanın mobilizasyonu sırasında oluşabilecek sert hareketleri göğüs tüpünün zarar görmemesi için yumuşatmaktadır. Sonuç olarak alt ekstremitelere giyilebilir modüler göğüs tüpü taşıma aparatı kullanımı ile göğüs drenaj şişesinin taşınırken düşmesi sonucunda ortaya çıkan komplikasyonların önlenmesi hedeflenmektedir. Bu sayede göğüs tüpüne sahip hastaların göğüs tüpü uygulaması sonrasında mobilize olurken göğüs tüpünü daha emniyetli ve konforlu bir şekilde gerçekleştirmeleri sağlanabilir.

Anahtar Kelimeler: Giyilebilir teknoloji, göğüs cerrahisi, göğüs tüpü, modüler, taşıma aparatı

1. Introduction

The lungs are made up of the pleura, a two-leaf membrane that surrounds the lungs. Pleura; it is divided into two as the parietal pleura, which is attached to the chest wall, and the visceral pleura, which surrounds the lungs [1]. Chest tube application is used in the treatment of lung diseases such as pneumothorax, hemothorax, pleural effusion and empyema, and in the drainage of blood and air accumulated in the pleural space after thoracic surgery [2]. The chest tube is inserted into the pleural space by making an incision in the intercostal space, after correct positioning, the entrance part of the tube is fixed by suturing with the skin and the other end of the tube is connected to the underwater seal chest drainage system. Due to this system, blood and air escape from the pleural space and the incoming drainage is prevented from returning. Observation of air bubbles inside liquid in the underwater seal chest drainage system is indicated that means the negative pressure holding the lungs together is maintained [3]. Proper use of the chest tube is required to achieve one-way drainage in the lungs and to maintain effective ventilation.

There are many factors can cause the problem about underwater seal chest drainage system. For

instance, the patient can lie on the chest tube, and the chest tube can bent, air leakage at the incision site, pain, bleeding and infection can occur. In the other hand, the tube can come out of the place where it is attached due to the movement of the patient during mobilization and the chest drainage bottle can overturned. Also, patient can keep the chest drainage bottle above the chest level and it can affect the working mechanism of the chest drainage system. In addition, the drainage bottle can fall on the ground and as a result of this, the formation of cracks or fractures in the bottle. [4-6]. In particular, the patient needs to be mobilized and perform activities such as walking, breathing and coughing exercises in order to recover in the postoperative period [7]. During mobilization, the patient carries the chest drainage bottle by holding the carrying strap on the top of the bottle, putting the bottle in a bag and connecting it to the IV pole. During transportation, the drainage bottle can be damaged and the chest tube can be dislodged due to reasons such as breaking the strap, tearing the bag, falling off the IV pole. By the reason of the dislocation of the chest tube, air fills the pleural space and the negative pressure in the lungs is replaced by positive pressure [8, 9]. Due to the increase in the positive pressure in the pleural cavity, the lungs cannot expand enough during breathing and the lungs deflate and lose their function. Bleeding, delayed wound healing, pain and infection develop because of the deformation of the sutures in the incision area where the tube is attached to the body [10]. Chest tube application for the patient's existing lung disease or chest surgery causes more complications due to inappropriate use of the chest tube, causing the patient to recover in the late period and prolonging the discharge time [11]. Since the pain in the incision area of the patient negatively affects the patient's position in the bed, movement, activities of daily living and adaptation to the treatment process, the patient avoids performing beneficial activities for recovery in this process [12].

In this study, it is aimed to introduce the modular chest tube carrying apparatus wearable for the lower extremities, which is designed to prevent problems that may occur in chest tube transport.

2. Design of Wearable Modular Chest Tube Carrying Apparatus for Lower Extremities

Modular chest tube delivery device wearable to lower extremities; It has a physical structure that can be worn on the lower extremities of the patient and consists of the body of the chest tube carrying apparatus (2), which can be attached to the patient's leg (1) of different thickness and where the chest tube is positioned (Figure 1). The springs of the chest tube carrying apparatus are made of stainless steel, and the other components are made of poly-based materials.

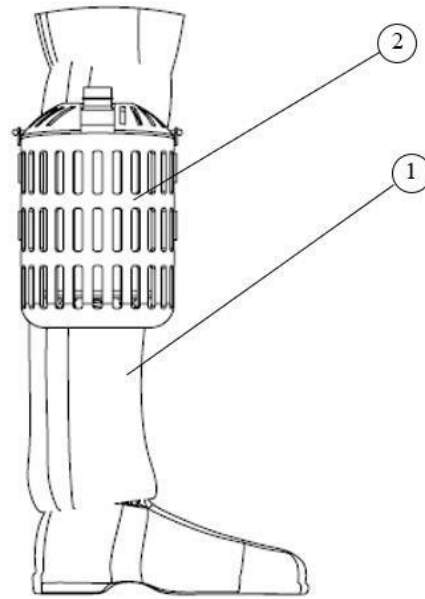

Figure 1: Side view of wearable modular chest tube carrying apparatus for lower extremities

The body of the chest tube carrying apparatus (2), which is attached to the patient's leg (1) with the leg attachment strap (3), has a ball joint (4) and can rotate 360° around the ball joint axis (4) (Figure 2). When the patient takes a step, with the effect of gravity and weight, the body of the chest tube carrying apparatus (2) rotates around the ball joint (4) and is always in a perpendicular position to the ground. There is a chest carrying apparatus unit cover (5) on the chest tube carrying apparatus body (2), and it prevents the chest tube (6), which is placed inside the chest tube carrying apparatus body (2), from coming off (Figure 3). The size of the chest tube can be produced in different sizes depending on the size of the bottle it is placed in. The standard size product, which is the subject of the design, is 28 cm high and 12 cm in diameter. The carrying capacity of the system is approximately 1.5 liters at maximum occupancy. Different designs are possible above and below these given dimensions.

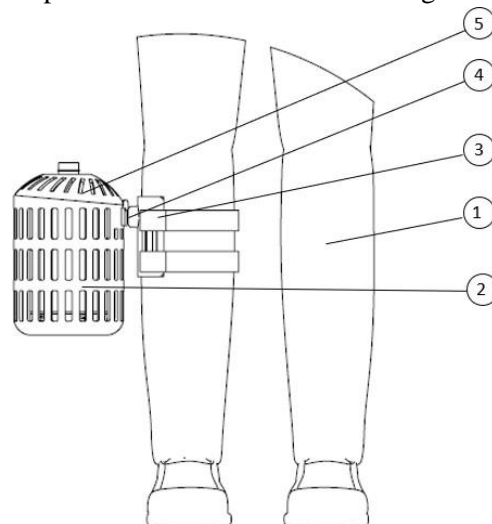

Figure 2: Front view of the wearable modular chest tube carrying apparatus for lower extremities

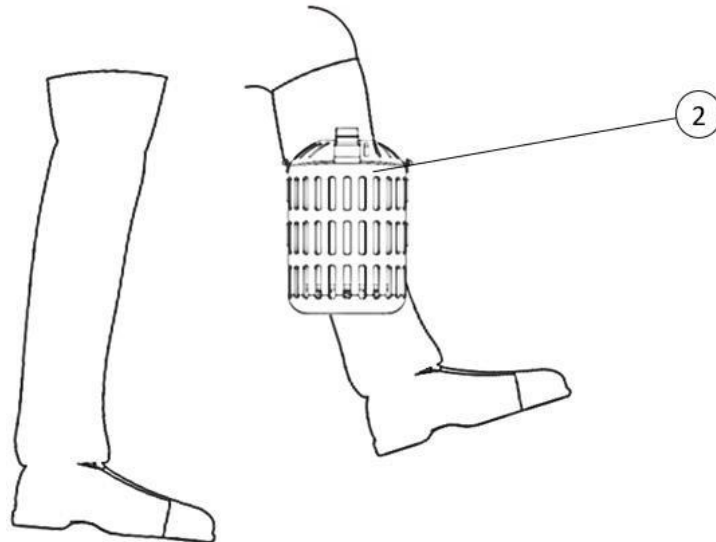

Figure 3: Side view of the wearable modular chest tube carrying apparatus for lower extremities with the patient in the walking position

The chest tube (6) is placed inside the carrying apparatus body (2) and the inner tray (7) inside the chest tube carrying apparatus body (2) and the spring (8) mechanism under this inner tray; it softens the hard impacts or movements that may occur during walking so that the patient does not damage the chest tube (6). It also ensures that short or long chest tubes (6) are seated between the chest tube carrying apparatus body (2) and the chest tube carrying apparatus unit cover (5). The chest tube (6) placed inside the chest tube carrying apparatus body (2) is fixed with the chest tube carrying apparatus unit cover (5) and locked with the lock mechanism (Figure 4, Figure 5, Figure 6).

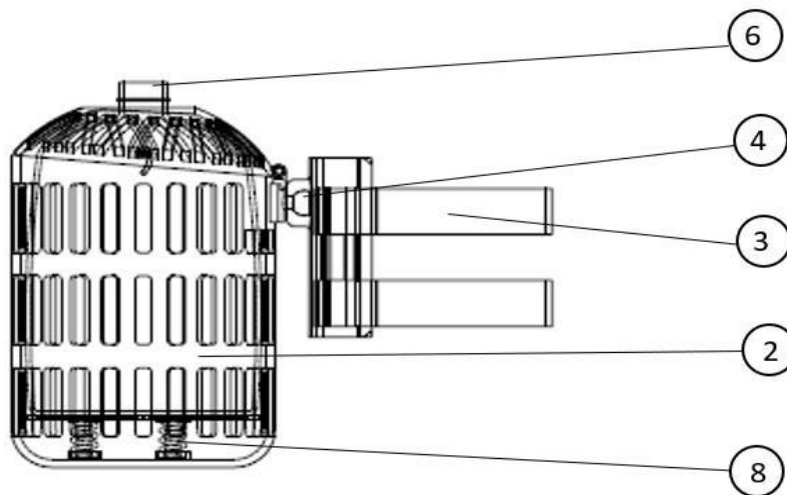

Figure 4: Frontal detail of the wearable modular chest tube carrying apparatus for lower extremities

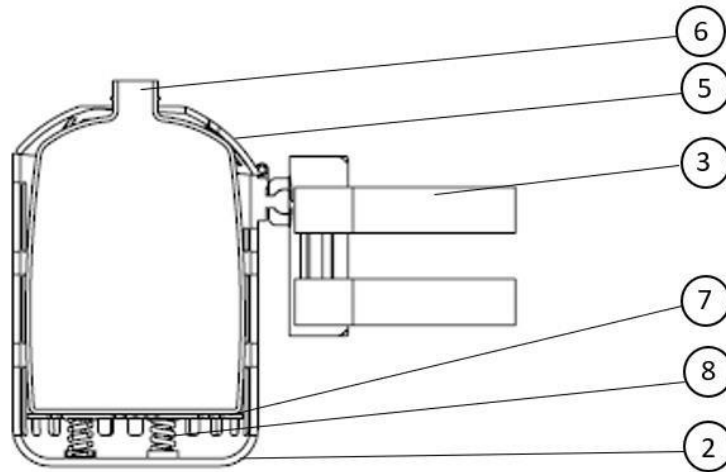

Figure 5: Interior sectional view of wearable modular chest tube carrying apparatus for lower extremities

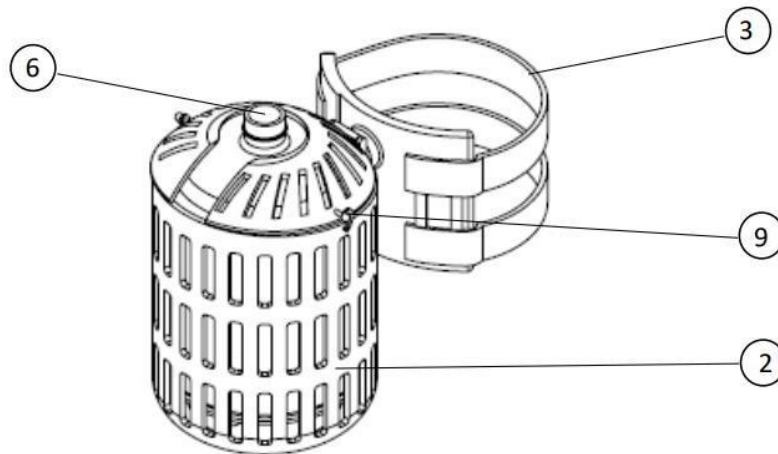

Figure 6: Perspective view of wearable modular chest tube carrying apparatus for lower extremities

3. Conclusions

As a result, with the wearable modular chest tube carrying apparatus that can be worn on the lower extremities, it can be ensured that the patients carry the chest tube more safely, prevent the complications that may occur as a result of the chest tube falling out, and mobilize the patients more easily. Since the chest transport tube will be carried standing up, there may be restrictions in walking movement at full load but different sizes can be designed for different body structures. Thus, it is thought that the use of chest tube carrying apparatus will contribute to reducing the problems that patients will experience while carrying the chest tube and to ensure patient safety.

4. Declarations

4.1. Study Limitations

The limitation of the study is the realization of the design based on the targeted features. In order to increase the generality of the study, it is recommended to carry out different design studies.

4.2. Acknowledgements

None.

4.3. Funding source

None.

4.4. Competing Interests

There is no conflict of interest in this study.

4.5. Authors' Contributions

All authors contributed to the development of the article topic, the creation of the design and the writing of the article.

References

- [1] Tomashefski JF and Farver CF. "Anatomy and Histology of the Lung". New York USA, Springer. Third Edition; 2008, 20–48. doi: 10.1007/978-0-387-68792-6_2 https://link.springer.com/chapter/10.1007/978-0-387-68792-6_2
- [2] Kuhajda I, Zarogoulidis K, Kougioumtzi I, Huang H, Li Q, Dryllis G, et al. "Tube thoracostomy; chest tube implantation and follow up". J Thorac Dis. 2014;6(4):470-479. doi:10.3978/j.issn.2072-1439.2014.09.23 <https://www.ncbi.nlm.nih.gov/pmc/articles/PMC4203990/>
- [3] Aydın İ. "Results of patients who underwent tube thoracostomy in the emergency department". Journal of Health Sciences of Adiyaman University. 2020;6(1):47–53. doi:10.30569.adiyamansaglik.635411 <https://dergipark.org.tr/en/download/article-file/1035946>
- [4] Ergin M, Yeğinsu A, Gürlek K. "Chest tube insertion". National Journal of Surgery. 2010;26(2):115-121. doi:10.5097/1300-0705.UCD.459-10.01 <https://turkjsurg.com/full-text/861/tur>
- [5] Kesieme EB, Dongo A, Ezemba N, Irekpita E, Jebbin N, Kesieme C. "Tube thoracostomy: complications and its management". Hindawi Publishing Corporation Pulmonary Medicine. 2012;1–10. doi:10.1155/2012/256878 <https://www.hindawi.com/journals/pm/2012/256878/>
- [6] Koçer B, Gülbahar G, Yildirim E, Dural K, Sakinci Ü. "Complications of tube thoracostomy in 603 patients". Turkey Clinics J Med Sci. 2010;30(3):895–899. <https://www.turkiyeklinikleri.com/article/en-tup-torakostominin-6-3-hastadaki-komplikasyonlari-58243.html>
- [7] Ahmad AM. "Essentials of physiotherapy after thoracic surgery: What physiotherapists need to know". A Narrative Review. The Korean Journal of Thoracic and Cardiovascular Surgery. 2018;51(5):293–307. doi:10.5090/kjtc.2018.51.5.293 <https://www.jchest Surg.org/journal/view.html?doi=10.5090/kjtc.2018.51.5.293>
- [8] Merkle A, Cindass R. "Care of A Chest Tube". [Updated 2021 Jan 17]. In: StatPearls [Internet]. Treasure Island (FL): StatPearls Publishing; 2021. <https://www.ncbi.nlm.nih.gov/books/NBK556088>
- [9] Mohammed HM. "Chest tube care in critically ill patient: A comprehensive review". Egyptian Journal of Chest Diseases and Tuberculosis. 2015;64(4):849–855. <https://doi.org/10.1016/j.ejcdt.2015.06.002>
- [10] Cook M, Idzior L, Bena JF, Albert NM. "Nurse and patient factors that influence nursing time in chest tube management early after open heart surgery: A descriptive, correlational study". Intensive and Critical Care Nursing. 2017;42:116–121. doi: <https://doi.org/10.1016/j.iccn.2017.03.008> <https://www.sciencedirect.com/science/article/abs/pii/S0964339716300763?via%3Dihub>
- [11] Schwellnus L, Roos R, Naidoo V. "Physiotherapy management of patients undergoing thoracotomy procedure: A survey of current practice in Gauteng". South African Journal of Physiotherapy. 2017;73(1):344. doi:10.4102/sajp.v73i1.344 <https://www.ncbi.nlm.nih.gov/pmc/articles/PMC6093126/>
- [12] Demir Y and Khorshid L. "Controlling pain during chest tube removal procedure: Literature Review". Journal of Ege University School of Nursing. 2008;24(2):113–126. <https://dergipark.org.tr/tr/download/article-file/835494>



© 2020 by the authors. Submitted for possible open access publication under the terms and conditions of the Creative Commons Attribution (CC BY) license (<http://creativecommons.org/licenses/by/4.0/>).