



Research Article

Numerical investigation of precast reinforced concrete beam-to-column joints by replaceable damper

Yalda DEHQAN NEZHAD¹, Sepanta NAİMİ^{2*}

¹Department of Civil Engineering, İstanbul Aydın University Faculty of Engineering, İstanbul, Türkiye

²Department of Civil Engineering, Altınbaş University Faculty of Engineering and Architecture, İstanbul, Türkiye

ARTICLE INFO

Article history

Received: 15 May 2022

Accepted: 02 June 2022

Key words:

Beam-to-column steel joint, finite element method, numerical simulation, precast concrete, replaceable damper

ABSTRACT

This study aimed to investigate the precast reinforced concrete beam-to-column joints behaviors through the replaceable damper under cyclic loading. The precast concrete specimens have been embedded with steel reinforcement and specially shaped connectors. After the application of the replaceable damper under cyclic loading, the energy dissipation shaped very well and increased the bearing capacity of precast specimens. The precast concrete beam-to-column joints were designed and analyzed to compare with the traditional reinforced concrete (RC) specimen. The analysis result of the loading based on the controlled displacement method showed that the precast specimen model with a damper has more hysterical behavior than the traditional RC frame. Also, the specimen (PS-1) is passed the 2.7% chord rotation, which showed higher performance, than the traditional RC specimen. The efficiency of the PS-1 specimen with a special connection has been elaborated with the finite element method (FEM) and simulated by ABAQUS software.

Cite this article as: Dehqan Nezhad, Y., Naimi, S. (2022). Numerical investigation of precast reinforced concrete beam-to-column joints by replaceable damper. *J Sustain Const Mater Technol*, 7(2), 81–87.

1. INTRODUCTION

The construction method of the precast specimens has increased widely by replacing them with the cast-in-situ reinforced concrete. Because of these significant advantages, which are the high quality of the specimen and making at the factories under traditional methods, with low cost. Also precast reinforced specimens could work even in the incompatible climate condition, and it has taken a little time for building, fewer workers need and has easily assembling possibility on-sit [1, 2]. Accordingly, the selec-

tion of the right technical method is very important for this aim. For the designer that's very important to receive a resolution, which receives the specimen to required performance in situations of the load-bearing capacity, and ductility [3]. Using the damper could increase the energy dissipation capacity [4]. The two different types of beams-to-column joints were presented with Precast Seismic constructions methods [5]. In this study analysis has done by applying cyclic loading on the concrete beam and column joints, which column was reinforced by (I) steel, the failure was reined by the good performance of the beam,

*Corresponding author.

*E-mail address: sepanta.naimi@altinbas.edu.tr



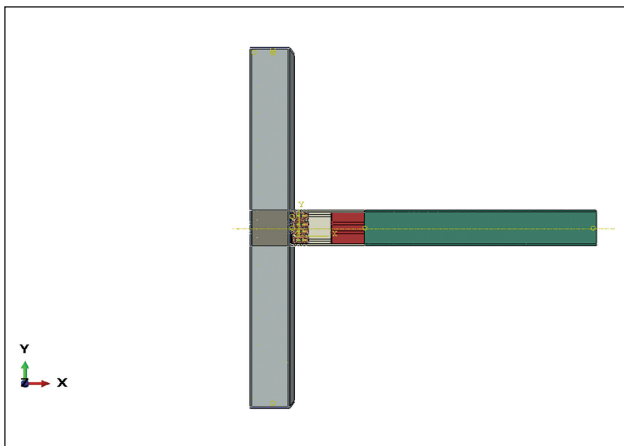

Figure 1. The type of connection between beam and column.

also, the connection valency relates to the shear valency of the beam [6]. The experimental test showed the negligible residual displacement at joints of beam-to-column, that is effect of pre-stressing force presented by steel strands. Hence the new type of beam-to-column joint expanded [7, 8]. On the other hand, the economic situation for transportation is also one of the most substantial parameters in the constructions industry, so using precast concrete may be use for subway construction [9]. The damper with friction presented for energy dissipation, which joints are showed a good self-centering capacity. For improving the energy dissipation capacity and loading capacity of self-centering capacity of beam-to-column joint was applied the replaceable mild steel bars [10]. This investigation had been used two structures to investigate the reinforcement's costs and the materials were utilized in this test. by using the nonlinear method and Sta4Cad achieved that building was reinforced by shear wall and had been shown better performance than the jacketed one [11]. The bamboo-shaped energy dissipater was used to present the energy dissipation capacity of the precast specimens, that showed the good performance [12]. Many experiments conducted, which are illustrated excellent behavior in the self-centering capacity and without strength degradation. Most of the time welded steel plates are used in the precast components because the steel plate joints commonly are useful for the integration of precast concrete structures. More experiments are shown excellent behavior in the self-centering capacity and without strength degradation. Most of the precast components were used the welded steels, because of that the steel joints commonly are useful to the integration of precast concrete structures [13]. As well as investigated the self-centering joints by using friction dampers and it has presented them in the experimental research [14]. Using four different precast sample connections with rigid, pinned, semi-rigid and new type connection to test strength, ductility and stiffness, the new connection type performed well as a semi-rigid joint [15].

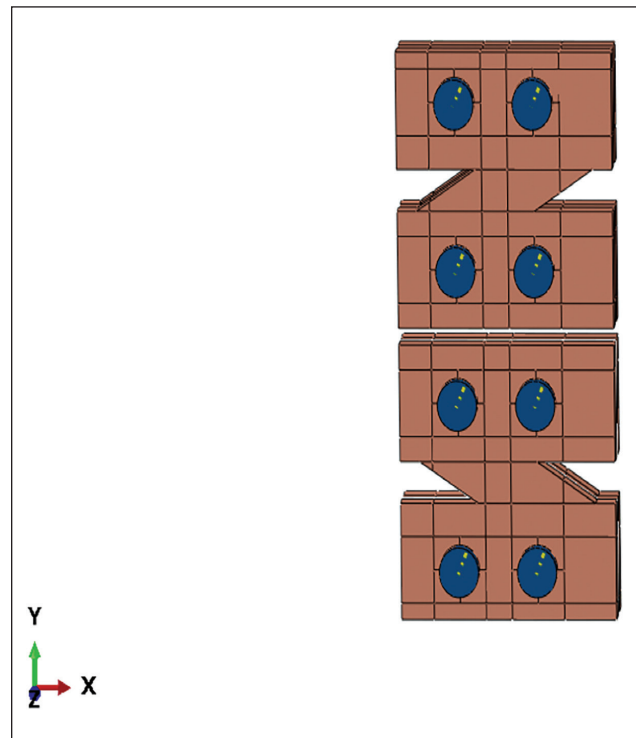

Figure 2. The damper shape.

This paper has investigated the behavior of Precast Concrete beam-to-column steel joints by using the replaceable damper under cyclic loading procedure. The main efficiency of this simulation is comparing to the monolithic model. The easy construction, the stiffness amount, the plastic hinge, increasing the energy dissipation of them, the ductility, energy dissipation factor, and strength of the specimen have been tested.

2. PROPOSED CONNECTION PARTS OF THE BEAM-TO-COLUMN

The type of connection parts of the beam-to-column joint simulation is illustrated in Figure 1. The special-shaped replaceable dampers are designed for energy dissipation capacity, which is shown in Figure 2. The special-shaped beam connector applied for connecting the beam to the column and utilized the special-shaped column connector part, which are shown in Figure 3. They are fastened together by bolts. The reinforcement bars, stirrups employed for resisting concrete, and the steel gusset plates are used for resisting the column. The two special designed plates are used for covering the concrete inside of cavity of the special shaped beam connector, which is shown in Figure 4. The cross-section areas of the precast beam-to-column joint and RC frame are illustrated in Figure 5. The gusset plates are used to avoid from the damage in column. All the parts dimensions are shown in Table 1.

Table 1. Parts dimension

Parts	Thickness (mm)	Height (mm)	Width (mm)	Length (mm)	Diameter (mm)	Web (mm)	Flange (mm)	Depth (mm)
Gusset	15	400	400	–	–	–	–	–
Covering plate	10	360	340	–	–	–	–	–
Bolts	–	–	–	–	21	–	–	–
Special B connector	–	–	250	750	–	12	20	400
Damper	15	165	165	–	–	–	–	–
Beam	–	400	250	3110	–	–	–	–
Column	–	400	400	4000	–	–	–	–

Table 2. Material properties

Material	Grade	Diameter Thickness (mm)	Yield strength (MPa)	Ultimate strength (MPa)
Reinforcement	HRB400	Ø8	407	644
	HRB400	Ø14	487	610
	HRB400	Ø16	436	634
Steel	Q345B	20	381	545
	Q235B	15	277	437
B concrete	–	–	–	40
C concrete	–	–	–	53

The moment expending along of the beam spend and the bending moment of the beam next to the steel joints, M_{C1} , and H steel at the free end M_{C2} [16].

$$M_{C1} \leq M_{CU1}$$

$$M_{C2} \leq M_{CU2}$$

The bending moment of concrete is shown by M_{cu1} next to steel joints, and the bending moment of the concrete next to the H steel is shown by M_{cu2} [16].

The bending moment of the proposed steel connection joint equation could be obtained with:

$$x = \frac{\frac{L1}{2} + L2 + L3}{L2 + L2} Mc1$$

$$x = \frac{\frac{L1}{2} + L2 + L3}{L2 + L3} Mc2$$

Where L is the beam length, L1 is the connection steel joints length, L2 is the H steel length, and L3 is the concrete length without reinforcement and H steel [16].

The ultimate bending moment of the steel joint can receive by:

$$Mpu \leq \min \left(\frac{L1 + L2 + L3}{L2 + L3} M_{cu1}, \frac{L1 + L2 + L3}{L2 + L3} M_{cu2} \right)$$

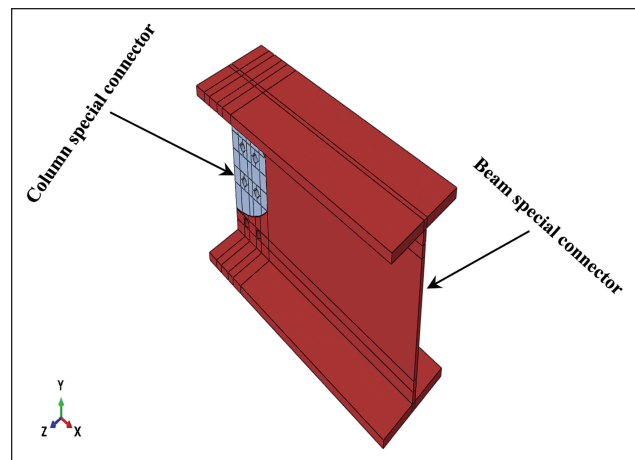

Figure 3. The beam and column special shaped connectors.

The dampers presented the bending moment of the steel joints after that, the ultimate bending moment in the damper's agreement with equation (5). In the tension and compression, the EDS of the dampers could be presented the bending moment capacity of the dampers [16].

$$2 \sum_{i=1}^3 Ai Di fi \leq \min \left(\frac{L1 + L2 + L3}{L2 + L3} M_{cu1}, \frac{L1 + L2 + L3}{L2 + L3} M_{cu2} \right)$$

Ai ($i=1, 2, 3$) is the DES area, Di ($i=1, 2, 3$) is the length between the DES, fi ($i=1, 2, 3$) is the stress at the EDS.

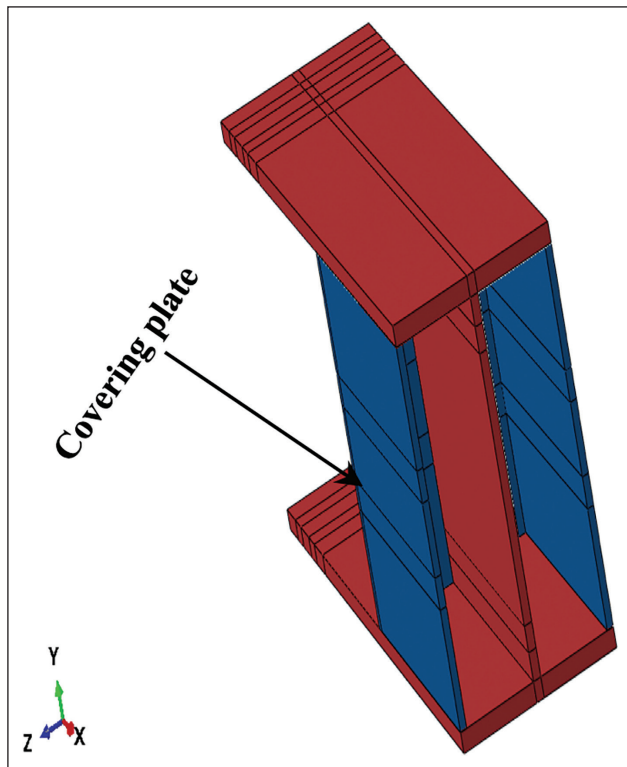

Figure 4. The special designed covering plates.

3. TEST STEP

The precast column boundary condition is located on the top and down by hinge support, and a 611 KN axial load is applied on the top of the column, which was equal to the 20% of the column bearing capacity. The displace-

ment at top of the column could be controlled by using the supported beam at the top of the column, and this supported beam is fixed by the reaction wall. The jack and anchorage parts is applied on the top of the column since the beam could be raised in the location. A 50 Ton actuator had been bounded in the strong floor to exert the cyclic loading at end surface of the beam.

4. MATERIAL PROPERTIES

The HRB400 steel used for reinforcement, and the Q345B, and Q235B was utilized for all steel parts and damper. The all-steels tension behavior tested [17]. The compressive strength of the concrete for the beam and the compressive strength of concrete for the column were tested [18]. All the materials were given in Table 2.

5. TEST PROCEDURE

A new precast beam-to-column joint was designed based on Geng et al. 2020 experimental models [19]. Also, the precast specimen compared with RC frame. The Z damper is applied in the PS-1 specimen, that is replaceable, and the concrete damages could be very slight. So, the damper could change after applying cyclic load. The same analysis can be done to obtain the characteristic of PS-1 joints as well. In this analysis the displacement-controlled loading has been used in every cyclic loading at this simulation. This procedure was repeated three times under displacement levels. The 5% drift amplitudes is shown in Figure 3. $\pm 0.25\%$, $\pm 0.5\%$, $\pm 0.75\%$, $\pm 1\%$, $\pm 1.5\%$, $\pm 2\%$, $\pm 2.5\% \pm 0.3\%$, $\pm 0.4\%$, and 0.5% respectively [20, 21].

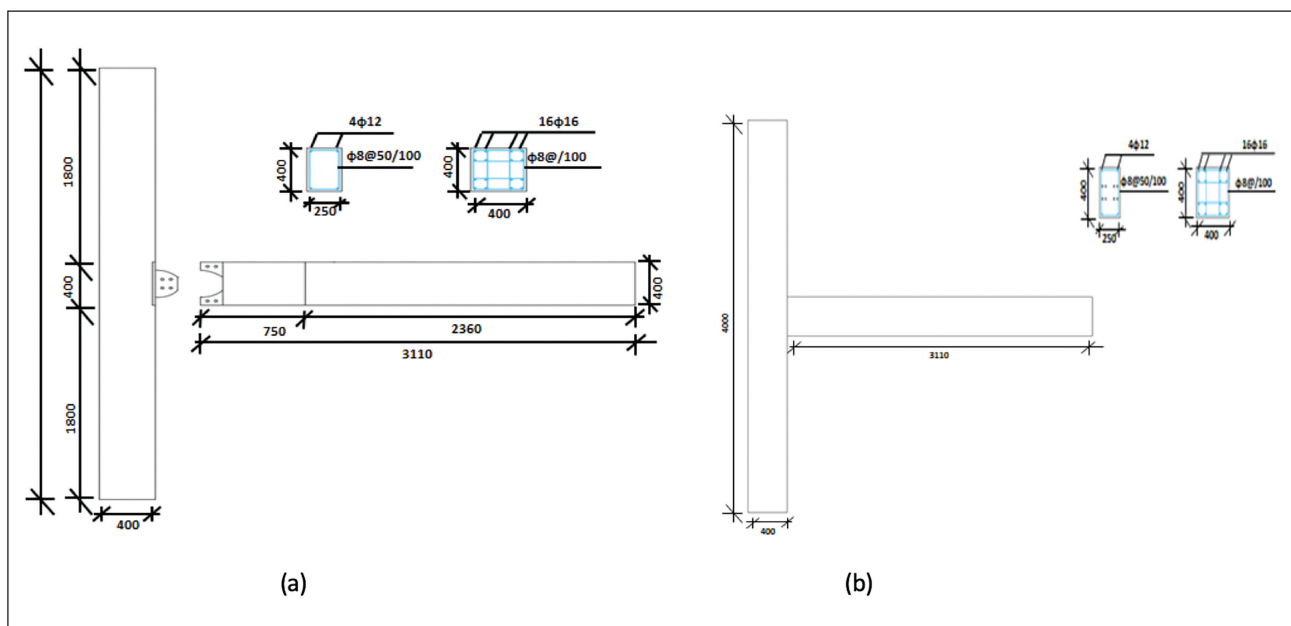

Figure 5. (a) The cross-section area of the precast concrete beam to column, and (b) the RC frame.

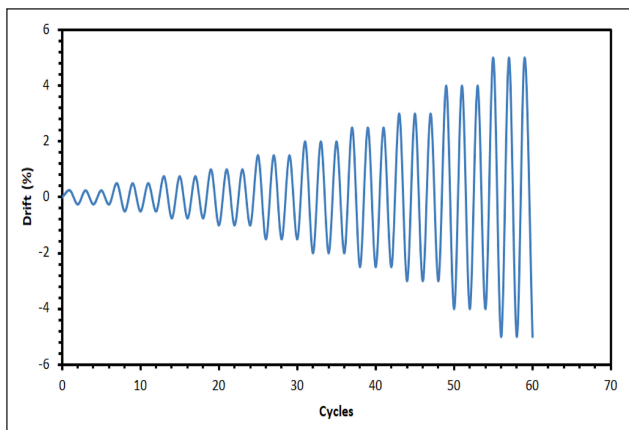

Figure 6. Loading protocol.

6. THE RESULT AND DISCUSSION

6.1. Load-Deformation

The moment rotation of the precast specimen PS-1, and the RC-1 frames are shown in the Figure 7. The moment rotation of the precast has compared with the RC frames.

The precast specimen model with damper was shown a greater hysteric behavior than the RC frame. The precast model was bounded with the replaceable damper and connected by special-shaped connectors. The precast specimen under cyclic loading was shown good performance. The chord rotation of the PS-1 has found as 2.7% and the RC-1 chord rotation has found as 2%, although, the resistance of the PS-1 has not increased.

6.2. The Stiffness Gradation

The stiffness of the PS-1 specimen was different from the RC-1, that has shown the different stiffness behavior. The equivalent stiffness was calculated by Secant stiffness of a point in the loading step. The equivalent stiffness specified the structure Elasto-Plastic state, that is illustrated in Figure 8.

The equivalent stiffness was analyzed in the maximum displacement point by first cycle of every level. The moment rotation of the specimens is shown in Figure 9.

The comparison of the rotation shows that the rotation of the PS-1 specimen is bigger than the rotation of RC-1, therefore the performance of PS-1 specimen is better than RC-1 specimen. The equivalent stiffness of the specimens is not sufficient to show the specifications of the specimens. The tangent stiffness of the two specimens is shown in Figure 10.

Because the damper has decreased the equivalent stiffness of the PS-1 specimen, where the equivalent stiffness of the RC-1 specimen was found 1.6 times greater than the PS-1 specimen.

Although, the PS-1 specimen presented less moment rotation than RC-1 specimens, the PS-1 sample with damper shows higher energy dissipation.

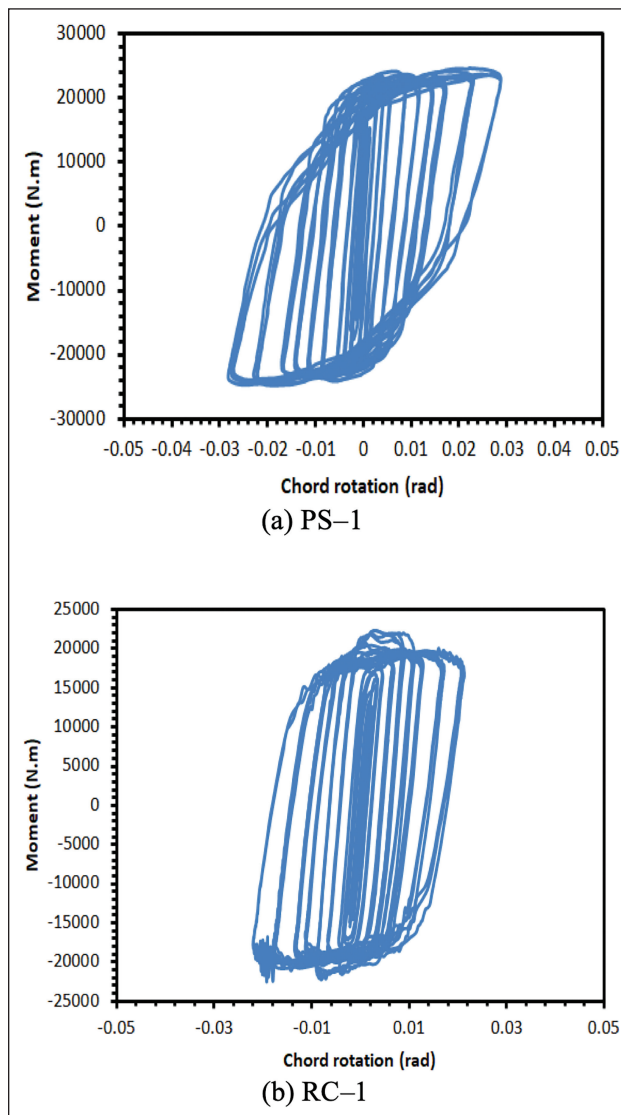

Figure 7. The moment rotation response of PS-1 (a), and the moment rotation response of RC-1 (b).

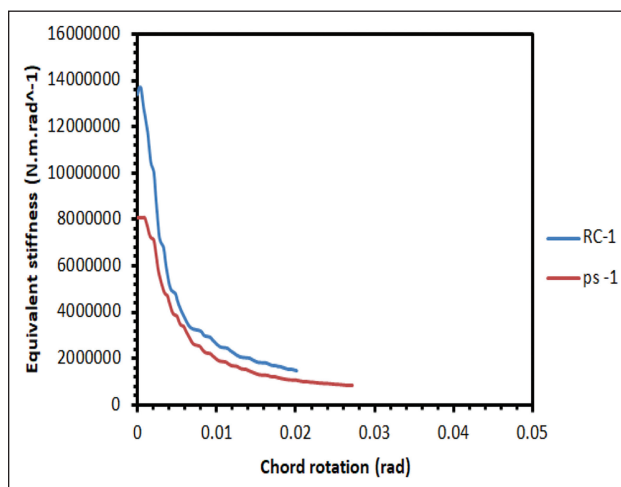

Figure 8. The equivalent stiffness of the PS-1 and RC-1.

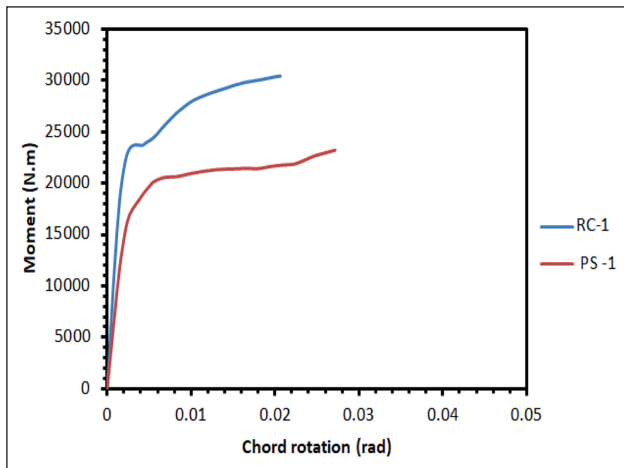

Figure 9. The moment rotation chord of PS-1 and RC-1.

The chord rotation of the PS-1 specimen has been found greater than RC-1 specimens, which has illustrated that PS-1 specimen was saved the damage under loading procedure. That means the damper increased greatly the chord rotation of the PS-1.

6.3. The Dampers Information

In this simulation, the Z-type damper is used, and the design of the Z-type damper with the specially shaped energy dissipation strip's goal was to avoid the untimely failure of the damper. The analysis result is illustrated the good performance of the Z-type damper with negligible deformation in the special-shaped strips of the Z-type damper after unloading. The Z type damper at the approximately 2.7% chord rotation wasn't shown the fracture and big deformation on the strips. The Q235B steel is used for the Z-type damper.

7. NUMERICAL STUDY AND DISCUSSION

7.1. Designing Approach

In this study, the efficiency of the PS-1 specimen with special connection has elaborated with finite element (FE) and simulated by ABAQUS software. The C3D8R elements have been used for simulating the concrete part, damper, and special-shaped connections. Also, From the T3D2 elements have been used for simulating the longitudinal reinforcement bars and stirrups. The contact behavior between dampers, bolts, special connection parts, concrete with the connector, and column with gusset plates have been applied for the connections. The column and beam connector have been simulated by the "tie" constraint. The cavity of the special beam connector and the concrete connection was done with contact pairs. The hard contact applied for all surfaces, and the tangential behavior chosen from the Coulomb friction type. The friction of 0.6 is used for contact between concrete and steel surface, and the friction of 0.15 is used for contact between steel surfaces. The load transformation at the damper was via the shear force between the screw hole and bolt. The

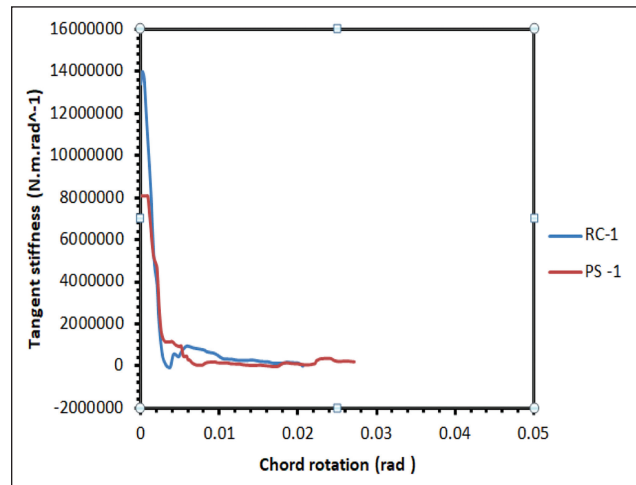

Figure 10. The tangent stiffness of PS-1 and RC-1 relationships with the moment chord rotation.

0.25 clearance has applied between screw and bolt, which has very effective on the hysteric response under small rotation.

8. CONCLUSION

In this study the precast reinforced concrete beam-to-column joints with replaceable damper under cyclic loading has been studied.

The precast specimen model with damper has shown a greater hysteric behavior than the RC frame.

1. The chord rotation of the PS-1 was 2.7% approximately, and the RC-1 chord rotation was 2%, as well as the resistance of the PS-1 was increased than RC-1.
2. Therefore, the equivalent stiffness of the PS-1 specimen was not greater than the RC-1 frame. Because the damper has decreased the equivalent stiffness of the PS-1 specimen. The tangent stiffness of the PS-1 specimen has not been increased more than RC-1 specimens.
3. The analysis result is illustrated the good performance of the Z-type damper with negligible deformation in the special-shaped strips of the Z-type damper after unloading. The Z type damper at the approximately 2.7% chord rotation wasn't shown the fracture and big deformation on the strips.

DATA AVAILABILITY STATEMENT

The authors confirm that the data that supports the findings of this study are available within the article. Raw data that support the finding of this study are available from the corresponding author, upon reasonable request.

CONFLICT OF INTEREST

The authors declare that they have no conflict of interest.

FINANCIAL DISCLOSURE

The authors declared that this study has received no financial support.

PEER-REVIEW

Externally peer-reviewed.

REFERENCES

- [1] Jaillon, L., Poon, C., & Chiang, Y. (2009). Quantifying the waste reduction potential of using prefabrication in building construction in Hong Kong. *Waste Management*, 29(1), 309–320. [CrossRef]
- [2] Yee, A. A. (2001). Social and Environmental Benefits of Precast Concrete Technology. *PCI Journal*, 46(3), 14–19. [CrossRef]
- [3] Breccolotti, M., Gentile, S., Tommasini, M., Materazzi, A. L., Bonfigli, M. F., Pasqualini, B., Colone, V., & Gianesini, M. (2016). Beam-column joints in continuous RC frames: Comparison between cast-in-situ and precast solutions. *Eng Struct*, 127, 129–144. [CrossRef]
- [4] Dyke, S. J., Spencer, B. F., Sain, M. K., & Carlson, J. D. (1998). An experimental study of MR dampers for seismic protection. *Smart Mater Struct*, 7(5), 693–703. [CrossRef]
- [5] M. J. N. (1988). Research needs for precast seismic structural systems. structural systems research (Report No: SSRP-88/0). University of California, San Diego.
- [6] Sermet, F., Ercan, E., Hökelekli, E., Arisoy, B. (2020). Cyclic behavior of composite column-reinforced concrete beam joints. *Sigma J Eng Nat Sci*, 38(3), 1427–1445.
- [7] Morgen, B. G., & Kurama, Y. C. (2007). Seismic Design of Friction-Damped Precast Concrete Frame Structures. *J Struct Eng*, 133(11), 1501–1511. [CrossRef]
- [8] Morgen, B. G., & Kurama, Y. C. (2004). A friction damper for post-tensioned precast concrete moment frames. *PCI J*, 49(4), 112–133. [CrossRef]
- [9] Vardar, T., Altan, M. F., & Naimi, S. (2017). Economic and technological evaluation of transportation system, new trends. *J Sustain Const Mater Technol*, 1(1), 83–88. [CrossRef]
- [10] Elliot, S., Bucklow, I. A., & Wallach, E. R. (1980). An examination of diffusion bonded interfaces in a mild steel. *J Mater Sci*, 15(11), 2823–2833. [CrossRef]
- [11] Olbak, M., Naimi, S. (2016). Kentsel dönüşüm uygulanmış 5 katlı iki yapı örneğinin deneysel verileri kullanılarak doğrusal olmayan analiz yöntemleri ile güçlendirme sonuçlarının irdelenmesi. *İstanbul Aydın Üniversitesi Dergisi*, 31, 145–166.
- [12] Wang, C. L., Liu, Y., & Zhou, L. (2018). Experimental and numerical studies on hysteretic behavior of all-steel bamboo-shaped energy dissipaters. *Eng Struct*, 165, 38–49. [CrossRef]
- [13] Shariatmadar H, Beydokhti E. Z. (2014). An investigation of seismic response of precast concrete beam to column connections: experimental study. *Asian J Civ Eng* 15(1), 41–59.
- [14] Xu, L. H., Fan, X. W., & Li, Z. X. (2016). Cyclic behavior and failure mechanism of self-centering energy dissipation braces with pre-pressed combination disc springs. *Earthq Eng Struct Dyn*, 46(7), 1065–1080. [CrossRef]
- [15] Noroozinejad Farsangi, E. (2010). Connections behaviour in precast concrete structures due to seismic loading. *GU J Sci*, 23(3), 315–325.
- [16] Li, Z., Qi, Y., & Teng, J. (2020). Experimental investigation of prefabricated beam-to-column steel joints for precast concrete structures under cyclic loading. *Eng Struct*, 209, Article 110217. [CrossRef]
- [17] GB/T 228.1. (2010). Metallic materials-tensile testing-Part 1: Method of test at room temperature. Standard Press. [Chinese]
- [18] GB/T50081. (2002). General administration of quality supervision, inspection, and quarantine of the people's republic of China. Standard for test method of mechanical properties on ordinary concrete. China Architecture & Building Press. [Chinese]
- [19] Li, Y., Geng, F., Ding, Y., & Wang, L. (2020). Experimental and numerical study of low-damage self-centering precast concrete frame connections with replaceable dampers. *Eng Struct*, 220, Article 111011. [CrossRef]
- [20] Huang, X., Zhou, Z., Xie, Q., Guo, C., & Li, C. (2018). Seismic analysis of friction-damped self-centering coupled-beams for moment-resisting-frames without floor elongation. *J Earthq Tsunami*, 12(05), Article 1850012. [CrossRef]
- [21] Huang, L., Zhou, Z., Huang, X., & Wang, Y. (2020). Variable friction damped self-centering precast concrete beam-column connections with hidden corbels: Experimental investigation and theoretical analysis. *Eng Struct*, 206, Article 110150. [CrossRef]