

## FRF Based Structural Modification of a Mechanical System by Adding Masses and Utilizing the Grey Wolf Optimization Technique

Murat ŞEN<sup>1\*</sup>, Osman YİĞİD<sup>2</sup>, Orhan ÇAKAR<sup>3</sup>

<sup>1,2,3</sup> Department of Mechanical Engineering, Engineering Faculty, Firat University, Elazığ, Türkiye

\*<sup>1</sup> msen@firat.edu.tr, <sup>2</sup> oyigid@firat.edu.tr, <sup>3</sup> cakaro@firat.edu.tr

(Geliş/Received: 25/07/2022;

Kabul/Accepted: 24/01/2023)

**Abstract:** Resonance and anti-resonance frequencies are important parameters that determine the dynamic behavior of mechanical systems. Changes in these parameters, which depend on the system's physical properties such as mass and stiffness, also affect the system's dynamic behavior. Finding the necessary structural modifications to adjust the resonance and anti-resonance frequencies of a system to the desired values is a study area of inverse structural modification. In this study, an inverse structural modification method for one and multi-rank modifications is presented. With the presented method some resonance or anti-resonance frequencies of mechanical systems can be shifted to prescribed values by calculating the necessary modifications. The presented method is based on Sherman-Morrison (SM) formula and uses the frequency response functions (FRF) of the original system directly. For one modification an exact solution is obtained on the other hand for two or more modifications some nonlinear set of equations has to be solved. A meta-heuristic optimization technique known as Grey Wolf Optimizer (GWO) is applied for the solution of the nonlinear equations. The method is applied to a six-degrees-of-freedom mass-spring system. Some resonance and anti-resonance frequencies in the frequency bandwidth of the system are selected as target frequencies. The necessary modification masses are calculated to match these frequencies. After applying the calculated masses to the system the target frequencies are obtained successfully.

**Key words:** Frequency response function, frequency shifting, grey wolf optimization, structural modification.

### Bir Mekanik Sistemin Kütle Eklenerek ve Bozkurt Optimizasyon Tekniği Kullanılarak FTF Tabanlı Yapısal Değişikliği

**Öz:** Rezonans ve ters rezonans frekansları, mekanik sistemlerin dinamik davranışını belirleyen önemli parametrelerdir. Sistemin kütle ve rijitlik gibi fiziksel özelliklerine bağlı olan bu parametrelerin değişimi sistemin dinamik davranışını da değiştirmektedir. Bir sistemin rezonans ve ters rezonans frekanslarını istenilen değerlere ayarlamak için gerekli yapısal değişiklikleri bulmak, ters yapısal değişiklik çalışma alanının konusudur. Bu çalışmada, tek ve çoklu değişiklikler için bir ters yapısal değişiklik yöntemi sunulmuştur. Bu yöntem ile mekanik sistemlerin bazı rezonans ve ters rezonans frekansları gerekli değişiklikler hesaplanarak istenilen değerlere kaydırılabilir. Sunulan yöntem Sherman-Morrison (SM) formülüne dayalı olup doğrudan orijinal sistemin frekans tepki fonksiyonlarını (FTF) kullanmaktadır. Tek bir değişiklik için kesin bir çözüm elde edilebilmektedir diğer yandan iki veya daha fazla değişiklik için bazı doğrusal olmayan denklem takımlarının çözülmesi gerekmektedir. Doğrusal olmayan bu denklemlerin çözümü için bu çalışmada, meta-sezgisel bir optimizasyon tekniği olan bozkurt optimizasyonu kullanılmıştır. Yöntem kütle ve yaylardan oluşan altı serbestlik dereceli bir sisteme uygulanmıştır. Sistemin frekans aralığında bazı rezonans ve ters rezonans frekansları hedef frekanslar olarak seçilmiştir. Bu frekansları yakalamak için gerekli kütle değişiklikleri hesaplanmıştır. Bu değişikliklerin uygulanmasıyla hedeflenen frekanslar başarılı bir şekilde elde edilmiştir.

**Anahtar kelimeler:** Frekans tepki fonksiyonu, frekans kaydırma, bozkurt optimizasyonu, yapısal değişiklik.

#### 1. Introduction

Resonance frequencies (natural frequencies) and anti-resonance frequencies are very important parameters that determine the dynamic behavior of mechanical systems. If a mechanical system is excited with a harmonic force with the same value as any of its natural frequencies, a resonance phenomenon occurs and the structure vibrates at high amplitudes. This situation can cause destructive effects on systems. For all that, at the anti-resonance frequencies, a certain point on the system does not vibrate against the harmonic force applied from a certain location of the system. For this reason, designers should consider these features while designing, manufacturing, and improving dynamic systems.

Resonance frequencies are the general (global) feature of the system. Therefore, they appear in all FRF graphs of the system, except for the nodal points. Anti-resonance frequencies are local features and they may not be seen

\* Corresponding author: [msen@firat.edu.tr](mailto:msen@firat.edu.tr). ORCID: <sup>1</sup> 0000-0002-3063-5635, <sup>2</sup> 0000-0002-1798-1250, <sup>3</sup> 0000-0001-6947-3875

in every FRF. In Figure 1 a point FRF and a transfer FRF are illustrated. It can be said from the graph that the resonance frequencies are seen in both points FRFs (the response and the excitation at the same location) and transfer FRFs (the response and the excitation at different locations), while the anti-resonance frequencies do not necessarily occur in transfer FRFs however they occur after every single resonance frequency in point FRFs.

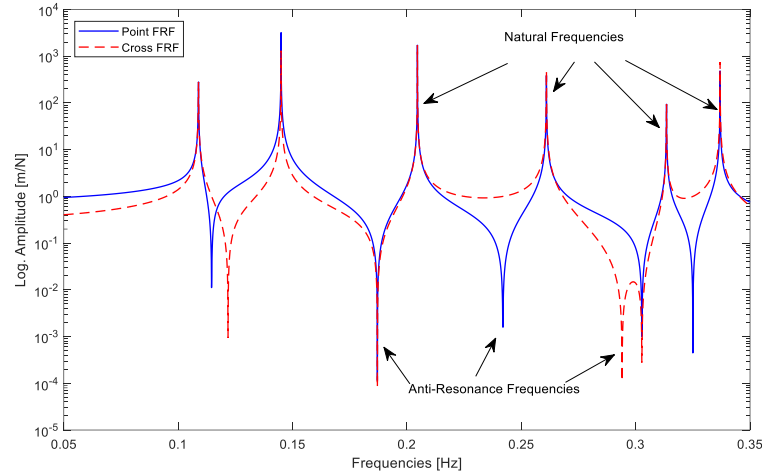

**Figure 1.** Point and cross FRFs of six degrees of freedom mass-spring system

The dynamic properties of a system, such as its natural frequencies, anti-resonance frequencies, and mode shapes depend on the physical properties of the system, such as mass, stiffness, and damping. When these physical properties of the system change, its dynamic behavior also changes. The relationship between the physical parameters and their effects on the dynamic characteristics is examined in the scope of the structural modification. Numerous studies e.g. mass-spring modification [1-4], rotational receptance modification [5], beam modification [6-9], transfer receptance based modification [10], and pole-zero cancellation [11] have been made over the last decades. The process of determining the dynamic properties of the modified system as a result of these structural modifications is called direct structural modification. The process of finding the modifications that must be made in the existing system to provide the desired dynamic properties is called inverse structural modification.

In structural modification applications, the results obtained from the finite element (FE) solution or when the FE model is difficult to form, the results obtained by the experimental modal analysis are used. In addition, FRFs are used directly in many studies [12-16]. FRFs can be obtained from numerical solutions or they can be obtained by measuring over physical structure in experimental applications. Experimental FRFs are preferred by many researchers in structural modification applications [17-18]. Researchers have been trying to find effective methods by continuing their studies for years on direct and inverse structural modifications. Tsuei and Yee [19] have presented a simple and effective method for inverse structural modification that uses FRFs of the system by changing the mass and stiffness values on an undamped system. They continued to work similarly on the damped systems to shift the damped natural frequencies to the desired values [20]. Ouyang and Zhang [21] have carried out structural modifications on two different mass-spring systems that are connected sequentially and complexly. They used two different methods in their work. One of the methods is based on the use of orthogonal similarity transformation and the real symmetric matrix obtained by using the eigenvalues planned to make structural modifications with the mass and stiffness matrices of the system transformed into the upper triangular matrix. In the other method, the new matrix to be created for structural modification is obtained by minimizing the difference between the desired eigenvalues and the isospectral matrices. Since the obtained changes are made in the specified region, it is suitable for structural modifications in the masses and springs in the desired location on the system and can be easily applied to physical systems. Liu et al. [22] presented a method based on the principle of using additional mass-spring systems for an undamped physical system and using FRFs of the system directly. Although the original system has not been changed and there are advantageous aspects of the method, the degree of freedom of the system increases due to the added masses. Mottershead and Ram [23] conducted a study on vibration isolation using the structural modification technique. Ouyang et al. [24] conducted a structural modification study using the FRFs of a dynamic system. They have made some limiting approaches to make the structural modification within the range of changes determined in terms of applicability and cost. Since the method they

proposed resolves the change to be made within a specified range and provides optimum value, it can be easily applied to real physical systems.

In many structural modification studies, it is seen techniques based on Sherman-Morrison (SM) formula [25] are used. The SM is a formula used to calculate the inverse of a modified matrix by using the inverse of the original matrix and the modifications and can be used effectively in structural modification problems based on FRFs. Çakar [26] proposed a method based on SM to calculate the stiffness of a spring to preserve a specified natural frequency value after adding a known mass on any specified location on a cantilever beam. In a different study [27], he used this method to prevent the desired natural frequency of the system from changing after the mass modification. In this study, a single frequency was taken into account and a successful result was obtained with an additional spring added between the structure and the ground in a chosen coordinate. However, as aircraft and spacecraft, it is impossible to make modifications by using grounded springs. Considering this situation, Hüseyinoğlu and Çakar [28] have kept the location of more than one frequency value fixed by adding more than one spring between two generalized coordinates instead of a grounded spring. Later, Çakar [29-30] presented studies including experimental applications related to shifting a certain number of natural frequencies of a system to desired values with mass modification. With the results obtained, it has shown that the proposed method is quite effective in calculating the masses required to shift one and more natural frequencies to desired values. Also, Çakar [31], Şen, and Çakar [32] proposed the same method to shift one and more anti-resonance frequencies to desired values successfully.

In this study, the resonance and anti-resonance frequencies of a six-degrees-of-freedom mass-spring system have been shifted to desired values with mass modifications based on the SM formula without the need for any matrix inversion. With the presented study, it can be said SM based-structural modification method can be used effectively on mechanical systems to solve some vibration problems. An exact solution is obtained for one modification, and for two or more modifications, some nonlinear set of equations is obtained. These nonlinear sets of equations should be solved numerically. There are many methods for solving nonlinear equation sets in literature. Recently, meta-heuristic optimization techniques have been widely used for this purpose e.g. Bee Colony Ant Colony and Particle Swarm [33], Spider [34, 35], and Grey Wolf [36] optimization techniques. In this study, GWO is used to solve the obtained set of nonlinear equations.

This paper is organized as follows: In Section 2, the mathematical formulations where the relevant equations used for numerical simulations are presented. In Section 3, numerical results for shifting both resonance and anti-resonance frequencies are given. The results are tabulated for the number of modifications and different modification coordinates. Finally, Section 4, presents the conclusions of this work.

## 2. Structural Modification Based on SM Formula

The SM is a formula for calculating the inverse of the new matrix resulting from a change to an existing matrix, using the inverse of the original matrix and modification vectors as given in Equation 1.

$$[A^*]^{-1} = [A]^{-1} - \frac{([A]^{-1}\{u\})(\{v\}^T[A]^{-1})}{1+\{v\}^T[A]^{-1}\{u\}} \quad (1)$$

Here,  $[A]$  is a non-singular square matrix. If the inverse of this matrix is available or known, the inverse of the modified  $[A^*]$  matrix resulting from a change to this matrix can be calculated using the inverse of  $[A]$  and the modification vectors. The change is expressed as the product of two vectors as follows.

$$[\Delta] = \{u\}\{v\}^T \quad (2)$$

Also, for a dynamic system, the dynamic stiffness matrix  $[Z]$  and the modified dynamic stiffness matrix  $[Z^*]$  resulting from the modification of  $[AZ]$  can be expressed as follows.

$$[Z^*] = [Z] + [\Delta Z] \quad (1)$$

Here, the modification in dynamic stiffness can be expressed as the product of two vectors as follows.

$$[\Delta Z] = \{u\}\{v\}^T \quad (4)$$

The inverse of the new matrix resulting from a modification in the dynamic stiffness matrix can be expressed in the form of the SM formula as in Equation 5, using the inverse of the original matrix and the modifications.

$$[Z^*]^{-1} = [Z]^{-1} - \frac{([Z]^{-1}\{u\})(\{v\}^T[Z]^{-1})}{1+\{v\}^T[Z]^{-1}\{u\}} \quad (5)$$

Considering the relationship ( $\alpha=Z^{-1}$ ) between the receptance and the dynamic stiffness, the FRFs of a modified system  $[\alpha^*]$  can be calculated by using the FRFs of the original system  $[\alpha]$  and the modifications  $\{u\}$ ,  $\{v\}$  without the need for any matrix inversion as in Equation 6.

$$[\alpha^*] = [\alpha] - \frac{([\alpha]\{u\})(\{v\}^T[\alpha])}{1+\{v\}^T[\alpha]\{u\}} \quad (6)$$

In Equation 6, the receptance type FRF matrix contains all elements in symmetric and square form. However, measuring the entire FRF matrix experimentally is a very laborious task. Therefore, Equation 6 given above can also be expressed with the active (response, excitation, and modification) coordinates only [29]. In this case, for a single mass modification, the following equation can be written for only the active  $p$  (response),  $q$  (excitation), and  $r$  (modification) coordinates for a specified element of the FRF matrix in the frequency range of interest of the modified system [13, 14].

$$\alpha_{pq}^* = \frac{\alpha_{pq} - \omega^2 \delta m (\alpha_{rr} \alpha_{pq} - \alpha_{pr} \alpha_{rq})}{1 - \omega^2 \delta m \alpha_{rr}} \quad (7)$$

Here,  $\delta m$  is the modification mass and  $\omega$  is the frequency in (rad/s). For Equation 7 the  $r^{th}$  elements of the modification vectors,  $\{u\}$  and  $\{v\}$  are  $u_r=1$  and  $v_r=-\omega^2 \delta m$  respectively and other elements are zero.

The resonance frequencies represent the poles of a system, and the anti-resonance frequencies represent zeroes. Based on this statement, if the denominator of Equation 7 is equated to zero, it is expected that peaks will form at these frequencies of the modified system. Therefore, the denominator of Equation 7 must be zero for the corresponding frequency value for the receptance of a modified system by adding a mass to the coordinate  $r$  to have a resonance frequency at a frequency of  $\omega_s$ .

$$1 - \omega_s^2 \delta m \alpha_{rr} = 0 \quad (8)$$

Using Equation 8, the modification mass that needs to be applied to the  $r^{th}$  coordinate for this modification can be easily calculated with the following equation as an exact solution.

$$\delta m = \frac{1}{\omega_s^2 \alpha_{rr}} \quad (9)$$

Similarly, if the numerator of Equation 7 is equated to zero, it is expected that reverse peaks will form at the FRFs for these frequencies of the modified system. Therefore, the numerator of Equation 7 must be zero for the corresponding frequency value for the receptance of a modified system by applying a modification mass to the coordinate  $r$  to have an anti-resonance frequency at a frequency  $\omega_s$ .

$$\alpha_{pq} - \omega_s^2 \delta m (\alpha_{rr} \alpha_{pq} - \alpha_{pr} \alpha_{rq}) = 0 \quad (10)$$

By using Equation 10, the required modification mass to be applied to the coordinate  $r$  for this modification can be easily calculated with the following equation as an exact solution.

$$\delta m = \frac{\alpha_{pq}}{\omega_s^2 (\alpha_{rr} \alpha_{pq} - \alpha_{pr} \alpha_{rq})} \quad (p, q \neq r) \quad (11)$$

In case of more than one modification, this formula can be applied sequentially. In this case, if  $n$  number of mass modifications are handled then this formula can be rewritten as follows.

$$[\alpha_a^i] = [\alpha_a^{i-1}] - \frac{-\omega^2 m^{(i)}([\alpha_a^{i-1}]\{u_i\})(\{v_i\}^T[\alpha_a^{i-1}])}{1 - \omega^2 m^{(i)}\{v_i\}^T[\alpha_a^{i-1}]\{u_i\}} \quad (i = 1, 2, \dots, n) \quad (12)$$

For a single FRF, Equation 12 can be written as follows.

$$\alpha_{pq}^i = \frac{\alpha_{pq}^{i-1} - \omega^2 m^{(i)} (\alpha_{rr}^{i-1} \alpha_{pq}^{i-1} - \alpha_{pr}^{i-1} \alpha_{rq}^{i-1})}{1 - \omega^2 m^{(i)} \alpha_{rr}^{i-1}} \quad (13)$$

If the system under consideration wanted to have  $n$  number of resonance frequencies at the frequencies of  $\omega_{s1}, \omega_{s2}, \dots, \omega_{sn}$ , this can be achieved sequentially with  $n$  mass modifications. For this, the FRFs of the last system obtained after mass modifications must go to infinity at these frequency values. In this case, for  $i=n$  in Equation 13 and the denominator of the equation must be equal to zero for each frequency value. Thus  $n$  number of interconnected nonlinear equations are obtained for  $n$  modifications on the system as follows.

$$\begin{aligned} F_1(m^i) &= 1 - \omega_{s1}^2 m^{(n)} \alpha_{rr}^{n-1}(\omega_{s1}) = 0 \\ F_2(m^i) &= 1 - \omega_{s2}^2 m^{(n)} \alpha_{rr}^{n-1}(\omega_{s2}) = 0 \\ &\dots \dots \dots \\ F_n(m^i) &= 1 - \omega_{sn}^2 m^{(n)} \alpha_{rr}^{n-1}(\omega_{sn}) = 0 \end{aligned} \quad (14)$$

In the same way, to shift  $n$  number of anti-resonance frequencies,  $n$  number of interconnected nonlinear sets of equations can be expressed for  $n$  modifications on the system as follows.

$$\begin{aligned} F_1(m^i) &= \alpha_{pq}^{n-1}(\omega_{s1}) - \omega_{s1}^2 m^{(n)} (\alpha_{rr}^{n-1}(\omega_{s1}) \alpha_{pq}^{n-1}(\omega_{s1}) - \alpha_{pr}^{n-1}(\omega_{s1}) \alpha_{rq}^{n-1}(\omega_{s1})) = 0 \\ F_2(m^i) &= \alpha_{pq}^{n-1}(\omega_{s2}) - \omega_{s2}^2 m^{(n)} (\alpha_{rr}^{n-1}(\omega_{s2}) \alpha_{pq}^{n-1}(\omega_{s2}) - \alpha_{pr}^{n-1}(\omega_{s2}) \alpha_{rq}^{n-1}(\omega_{s2})) = 0 \\ &\dots \dots \dots \\ F_n(m^i) &= \alpha_{pq}^{n-1}(\omega_{sn}) - \omega_{sn}^2 m^{(n)} (\alpha_{rr}^{n-1}(\omega_{sn}) \alpha_{pq}^{n-1}(\omega_{sn}) - \alpha_{pr}^{n-1}(\omega_{sn}) \alpha_{rq}^{n-1}(\omega_{sn})) = 0 \end{aligned} \quad (15)$$

Equations 14-15 contain unknown nested mass values. By solving this set of equations numerically, the necessary modification mass values can be calculated. It should be noted here that each modified FRF needed in Equations 14-15 can be obtained from Equation 13. To solve these equations, the GWO technique was used in this study. This technique is developed and well described in the reference [36] which uses the social hierarchy, encircling prey, hunting, attacking, and searching for prey of the wolves. So, detailed mathematical formulations for this optimization technique are not given in this study.

### 3. Numerical Applications

In this section, the applications for shifting some natural frequencies and some anti-resonance frequencies of a six-degree-of-freedom system consisting of masses and springs, which are frequently used in the literature [29] to the desired values are given respectively.

Numerical applications have been performed on the system given in Figure 2, all masses are considered as 1 kg and all springs are equal to 1 N / m.

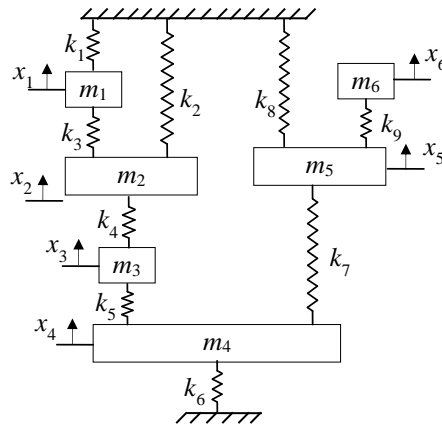

**Figure 2.** Six degrees of freedom mass-spring system [29]

In the applications, it is aimed to obtain the desired frequencies by making mass modifications on the selected FRFs shown in Figure 3.

The FRFs of the original system were obtained in the 0.0000-0.3500 Hz frequency bandwidth at intervals of 0.0001 Hz and for this system the FRFs of  $\alpha_{33}$  and  $\alpha_{34}$  are illustrated in Figure 3 together.

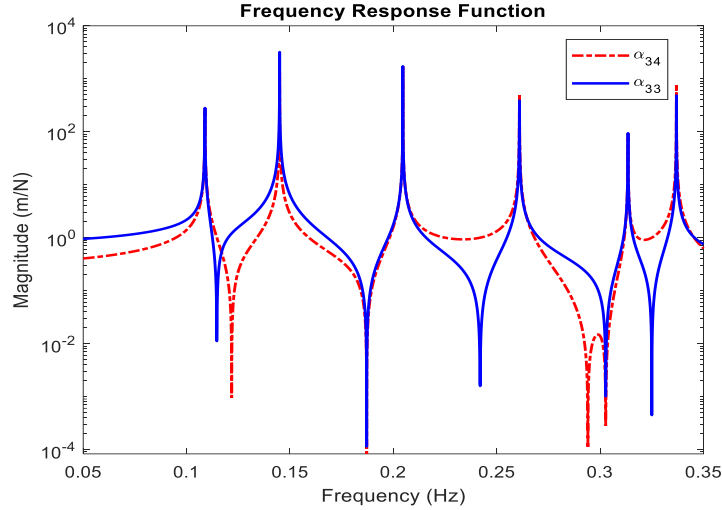

**Figure 3.** The FRFs of the original system ( $\alpha_{33}$  and  $\alpha_{34}$ ).

In addition, the natural frequencies and eigenvectors of the system are given in Table 1.

**Table 1.** The natural frequencies, anti-resonance frequencies for  $\alpha_{33}$  and eigenvectors of the original system.

Modes	1	2	3	4	5	6
Natural Frequencies (Hz)	0.1089	0.1450	0.2046	0.2610	0.3135	0.3369
Anti-resonance Frequencies $\alpha_{33}$ (Hz)	0.1146	0.1871	0.2420	0.3027	0.3250	-
Eigenvectors	0.0962	-0.4027	0.7451	-0.3310	-0.3761	-0.1496
	0.1473	-0.4712	0.2588	0.2280	0.7068	0.3711
	0.2769	-0.6199	-0.3965	0.4019	-0.2455	-0.4001
	0.2769	-0.2541	-0.3965	-0.5049	-0.2455	0.6216
	0.4242	0.0685	-0.1377	-0.5590	0.4613	-0.5206
	0.7973	0.4027	0.2110	0.3310	-0.1602	0.1496

### 3.1. Mass Modifications for Shifting Natural Frequencies

As mentioned earlier, the proposed method can be used to shift a single natural frequency or a single anti-resonance frequency to a desired value with a single mass modification as an exact solution. The main problem here is to shift more than one natural frequency or anti-resonance frequency to the desired values with multiple mass modifications.

For shifting the natural frequencies to the desired values, the objective functions can be expressed as follows.

$$F_{obj} = |F_i| \quad (i = 1, 2, \dots, n) \quad (16)$$

A number of grey wolves and the iteration were chosen as 50 and 500 respectively. Also, the constraints were chosen for the modification mass values as follows.

$$m_{min} < m_i < m_{max} \quad (i = 1, 2, \dots, n) \quad (17)$$

For all masses lower and upper bounds are chosen as  $m_{min} = -1$  and  $m_{max} = 1$  respectively.

In Table 2, applications of some modifications for desired natural frequencies with some selected coordinates are given. Calculated masses and obtained natural frequencies by using these applied mass values are given for both two and three modification cases.

**Table 2.** The natural frequencies of the system after multi-mass modifications.

Desired Frequencies	Modification Coordinates	Calculated Masses	Natural Frequencies of Modified System					
0.1840 0.3030	1	0.1964	0.1027	0.1262	<b>0.1840</b>	0.2503	<b>0.3030</b>	0.3284
	3	0.8786						
0.1000 0.2000	1	0.1077	0.1043	0.1395	<b>0.1840</b>	0.2366	<b>0.3030</b>	0.3184
	4	0.9162						
0.1000 0.2000	2	0.2174	<b>0.1000</b>	0.1411	<b>0.2000</b>	0.2274	0.2861	0.3187
	5	0.9037						
0.0915 0.2015 0.3015	1	-0.2709	<b>0.1000</b>	0.1419	<b>0.2000</b>	0.2571	0.3113	0.3359
	6	0.2759						
0.0915 0.2015 0.3015	1	-0.2709	<b>0.0915</b>	0.1374	<b>0.2015</b>	0.2538	<b>0.3015</b>	0.3317
	4	0.7015						
0.1000 0.2000 0.3000	6	0.5440						
	3	0.2263	<b>0.1000</b>	0.1375	<b>0.2000</b>	0.2329	<b>0.3000</b>	0.3216
0.1000 0.2000 0.3000	5	0.5289						
	6	0.1079						

The desired frequencies in the frequency range and the modification coordinates, are selected randomly. The negative calculated mass value means the mass has to be removed from the system. According to the results in Table 2, the desired resonance frequencies are obtained successfully.

Some FRFs of the modified systems for the applications given in Table 2 are given in Figures 4-5 below.

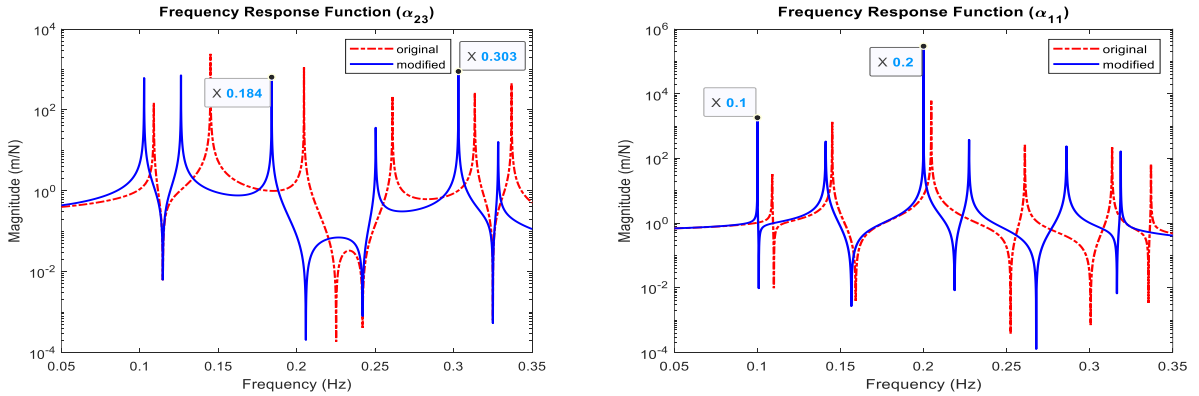

**Figure 4.** The FRFs of the original and the modified system for two desired resonance frequencies

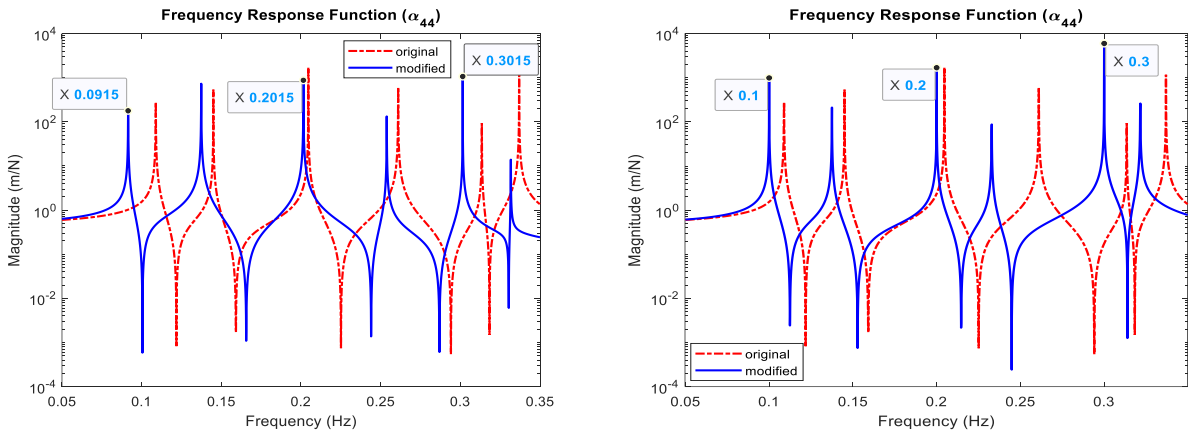

**Figure 5.** The FRFs of the original and the modified system for three desired resonance frequencies

As seen in Figures 4-5, the desired frequencies were obtained successfully after applying the calculated mass values to the system.

### 3.2. Mass Modifications for Shifting Anti-resonance Frequencies

In Table 3, applications of some modifications for desired anti-resonance frequencies with some selected coordinates are given. Calculated masses and obtained anti-resonance frequencies by using these applied mass values are given for both two and three modification cases. The modifications were made for  $\alpha_{33}$  and the modification coordinates were selected randomly.

**Table 3.** The anti-resonance frequencies of the system after multi-mass modifications.

Desired Frequencies	Modification Coordinates	Calculated Masses	Anti-resonance Frequencies of Modified System				
0.1700 0.2200	1	0.2816	0.1077	<b>0.1700</b>	<b>0.2200</b>	0.2943	0.2949
	5	0.6644					
	2	0.6092	0.1140	<b>0.1700</b>	<b>0.2200</b>	0.2627	0.3115
	4	0.3308					
0.1000 0.3000	1	0.0718	<b>0.1000</b>	0.1824	0.2367	<b>0.3000</b>	0.3227
	6	0.3927					
	4	0.0256	<b>0.1000</b>	0.1864	0.2367	<b>0.3000</b>	0.3227
	6	0.3927					
0.1000 0.2000 0.3000	1	-0.1790	<b>0.1000</b>	0.1905	<b>0.2000</b>	0.3127	<b>0.3000</b>
	4	0.0070					
	5	0.4401					
	6	0.3927					
0.1050 0.2050 0.3050	2	-0.0201	<b>0.1050</b>	0.1876	<b>0.2050</b>	0.2606	<b>0.3050</b>
	4	0.3805					
	5	0.8688					

Also, some FRFs of the modified systems for the applications of shifting anti-resonance frequencies given in Table 3 are illustrated in Figure 6 and Figure 7 below.

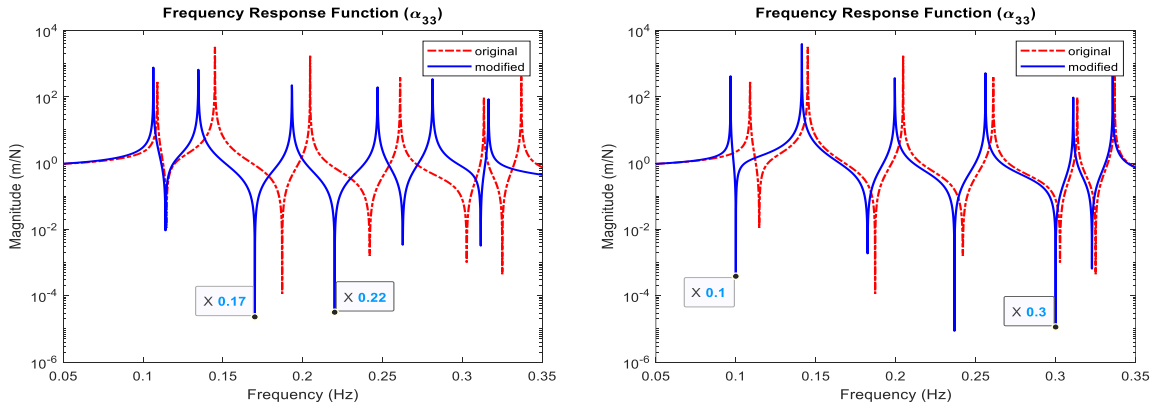

**Figure 6.** The FRFs of the original and the modified system for two desired anti-resonance frequencies



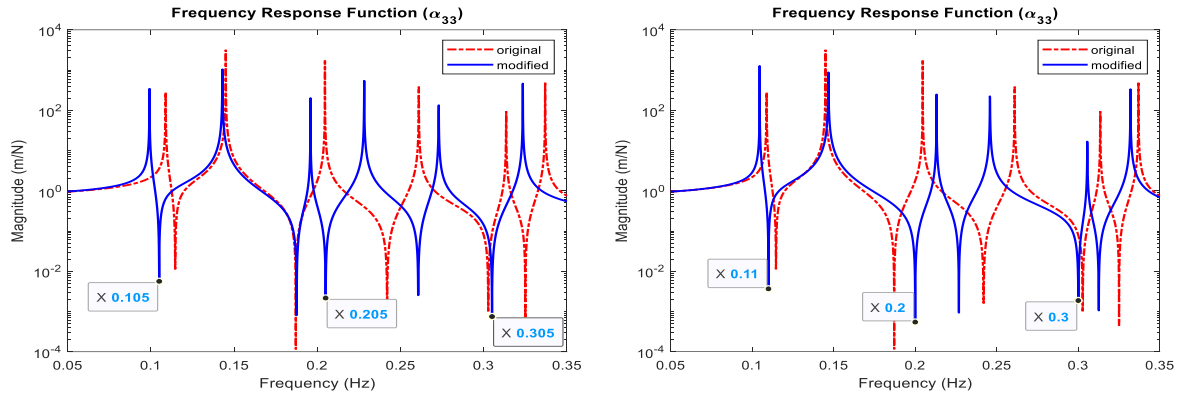

**Figure 7.** The FRFs of the original and the modified system for three desired anti-resonance frequencies

#### 4. Results and Discussion

In this study, to contribute to the solution of vibration problems, a method is presented for shifting one or more natural frequencies and anti-resonance frequencies of mechanical systems to desired values by making mass modifications in specified coordinates and its validity is proven by some numerical applications. The proposed method in the study is based on the SM formula known from mathematics and calculates the required masses directly using the FRFs of the system. In this respect, it is quite suitable for practical applications as the FRFs can be obtained from real mechanical systems with modal tests. An equation with an exact solution is obtained in the case of a single frequency shifting. In case of shifting more than one frequency, the nonlinear equation sets consisting of equations as many as the number of frequencies to be shifted must be solved numerically. In this study, these nonlinear equation sets are solved by using the GWO technique. The presented method is applied to a six-degrees-of-freedom mass-spring system. The frequency-magnitude FRF graphs are obtained within a bandwidth containing all the resonance frequencies. In this bandwidth, some target frequencies are matched with calculated mass modifications successfully. The results are given with tables and FRF graphs. According to the results gained from the numerical applications, the presented method can be said to be very effective and applicable to physical systems. In this presented study, for multi-rank modifications, the number of modifications and target frequencies are considered the same. In this case, non-linear equation sets combined with equations with the same number of modifications are obtained for both resonance and anti-resonance frequency shifting. But, it can also be possible for a different number of modifications and equations as under-determined or over-determined equation sets. Also, an optimization study of coordinates and modification type as stiffness and/or mass can be used for obtaining more feasible results for future studies.

#### References

- [1] Braun SG, Ram YM. Modal modification of vibrating systems: some problems and their solutions. *Mech Syst Signal Process* 2001; 15(1): 101–119.
- [2] Kyprianou A, Mottershead JE, Ouyang H. Assignment of natural frequencies by an added mass and one or more springs. *Mech Syst Signal Process* 2004; 18(2): 263–289.
- [3] Ram YM. *Dynamic Structural Modification*. The Shock and Vibration Digest 2000; 32(1): 11-17.
- [4] Sivan DD, Ram YM. Mass and stiffness modifications to achieve desired natural frequencies. *Commun Numer Methods Eng*. 1996; 12(9): 531–542.
- [5] Mottershead JE, Kyprianou A, Ouyang H. Structural modification. Part 1: Rotational receptances. *J Sound Vib* 2005; 284(1–2): 249–265.
- [6] Kyprianou A, Mottershead JE, Ouyang H. Structural modification. Part 2: Assignment of natural frequencies and anti-resonances by an added beam *J Sound Vib* 2005; 284(1–2): 267–281.
- [7] Bucher I, Braun S. The Structural modification inverse problem: An exact solution. *Mech Syst Signal Process* 1993; 7(3): 217-238.
- [8] Zhu J, Mottershead JE, Kyprianou A. An inverse method to assign receptances by using classical vibration absorbers. *J Vib Control* 2009; 15(1): 53–84.
- [9] Mottershead JE, Mares C, Friswell MI. An inverse method for the assignment of vibration nodes. *Mech Syst Signal Process* 2001; 15(1): 87-100.

- [10] Sanlitürk KY. An efficient method for linear and nonlinear structural modifications. Proceedings of ESDA 2002: 6th Biennial Conference on Engineering Systems Design and Analysis 2002; İstanbul, Turkey, 028-040.
- [11] Mottershead JE, Lallement G. Vibration nodes, and the cancellation of poles and zeros by unit-rank modifications to structures. *J Sound Vib* 1999; 222(5): 833-851.
- [12] Park YH, Park YS. Structural modification based on measured frequency response functions: an exact eigenproperties reallocation. *J Sound Vib* 2000; 237(3): 411-426.
- [13] Mottershead J. Structural modification for the assignment of zeros using measured receptances. *Journal of Applied Mechanics* 2001; 68(5): 791-798.
- [14] Prells U, Mottershead JE, Friswell MI. On pole-zero placement by unit-rank modification. *Mech Syst Signal Process* 2003; 17(3): 611-633.
- [15] Çakar O, Şanlıtürk KY. Elimination of suspension effects from measured frequency response functions. 9th International Research/Expert Conference, Trends in the Development of Machinery and Associated Technology 2005; Antalya, Turkey.
- [16] Mottershead JE. On the zeros of structural frequency response functions and their sensitivities. *Mech Syst Signal Process* 1998; 12 (5): 591-597.
- [17] Şanlıtürk KY, Çakar O. Noise elimination from measured frequency response functions. *Mech Syst Signal Process* 2005; 19 (3): 615-631.
- [18] Çakar O, Sanlitürk KY. Elimination of transducer mass loading effects from frequency response functions. *Mech Syst Signal Process* 2005; 19(1): 87-104.
- [19] Tsuei YG, Yee EKLA. method for modifying dynamic properties of undamped mechanical systems. *ASME J Dyn Syst Meas Control* 1989; 111: 403-408.
- [20] Yee EKL, Tsuei YG. Method for shifting natural frequencies of damped mechanical systems. *AIAA Journal* 1991; 29(11).
- [21] Ouyang H, Zhang J. Passive modifications for partial assignment of natural frequencies of mass-spring systems. *Mech Syst Signal Process* 2015; 50-51: 214-226.
- [22] Liu Z, Li W, Ouyang H, Wang D. Eigenstructure assignment in vibrating systems based on receptances. *Arch Appl Mech* 2015; 85(6): 713-724.
- [23] Mottershead JE, Ram YM. Inverse eigenvalue problems in vibration absorption: Passive modification and active control. *Mech Syst Signal Process* 2006; 20: 5-44.
- [24] Ouyang H, Richiedei D, Trevisani A, Zanardo G. A convex-constrained modification method based on receptances. *Mech Syst Signal Process* 2012; 27: 397-409.
- [25] Sherman J, Morrison WJ. Adjustment of an inverse matrix corresponding to a change in one element of a given matrix. *Ann Math Stat* 1950; 21 (1): 124-127.
- [26] Çakar O. Bir konsol kirişin belirli bir doğal frekansını değiştirmeksizin kütle ve ay eklenmesi. 14. Ulusal Makine Teorisi Sempozyumu (UMTS 2009); 2009; Kıbrıs; 183-190.
- [27] Çakar O. Mass and stiffness modifications without changing any specified natural frequency of a structure. *J Vib Control* 2011; 17(5): 769-776.
- [28] Huseyinoglu M, Çakar O. Determination of stiffness modifications to keep certain natural frequencies of a system unchanged after mass modifications. *Arch Appl Mech* 2017; 87(10): 1629-1640.
- [29] Çakar O. Bir Sistemin Doğal Frekanslarının Kütle Eklenerek Kaydırılması Üzerine Bir Çalışma. 18. Ulusal Makine Teorisi Sempozyumu (UMTS 2017); 2017; Trabzon, Turkey; 380-386.
- [30] Çakar O. A method for shifting natural frequencies of a dynamic system to desired values with concentrated mass modifications. *J Vibroeng* 2018; 20(1): 1-12.
- [31] Çakar O. Mekanik bir sistemin bir ters rezonans frekansının kütle eklenerek değiştirilmesi. *Fırat Üniversitesi Mühendislik Bilimleri Dergisi* 2018; 30(2): 127-134.
- [32] Şen M, Çakar O. Bir sistemin ters rezonans frekanslarının kütle eklenerek istenilen değerlere kaydırılması. 19. Ulusal Makine Teorisi Sempozyumu (UMTS 2019); 2019; İskenderun, Turkey; 321-328.
- [33] Stojanovi I, Brajevi I, Stanimirovi PS, Kazakovtsev LA, Zdravev Z. Application of heuristic and metaheuristic algorithms in solving constrained weber problem with feasible region bounded by arcs. *Math Probl Eng* 2017: 1-13.
- [34] Cuevas E, Cienfuegos M. A new algorithm inspired in the behavior of the social-spider for constrained optimization. *Expert Systems with Applications* 2014; 41: 412-425.
- [35] Baydoğan C, Alatas B. Sentiment analysis in social networks using social spider optimization algorithm. *Technical Gazette* 2021; 28(6): 1943-1951.
- [36] Mirjalili S, Mirjalili SM, Lewis A. Grey Wolf Optimizer. *Adv Eng Software* 2014; 69: 46-61.