

OUR CLINICAL EXPERIENCE IN THE PALLIATIVE CARE CENTER OF A TRAINING AND RESEARCH HOSPITAL IN EASTERN TURKEY BETWEEN 2018 AND 2019: A RETROSPECTIVE STUDY

Hasan ÖZTİN¹, Erkan Cem ÇELİK^{2✉}

1. İzmir Katip Çelebi University, Atatürk Education ve Research Hospital, Department of Internal Medicine and Geriatrics, Izmir, TURKEY.

2. Atatürk University, Faculty of Medicine, Department of Anesthesiology and Reanimation Department, Erzurum, TURKEY.

ORCID: 0000-0002-8983-0021^a, 0000-0002-7773-9562^b

Geliş Tarihi/Received	Kabul Tarihi/Accepted	Yayın Tarihi/Published
16.02.2022	23.02.2022	28.02.2022

Bu makaleye atıfta bulunmak için/To cite this article:

Oztin H, Çelik EC. Our clinical experience in the palliative care center of a training and research hospital in eastern turkey between 2018 and 2019: a retrospective study. *Journal of surgical medical sciences, J Surg. Med. Sci.* 2022; 1(1):8-12

Abstract

Objective: As a result of the advancements in the field of medicine, there has been a positive increase in the life span and quality of life of human beings, so people increasingly need quality care. This study aimed to retrospectively evaluate the working principle of the palliative care unit in a training and research hospital and the patients hospitalized in the palliative care unit between 2018-2019. **Methods:** After obtaining approval from the local ethics committee, patients who were hospitalized in the palliative care center of a training and research hospital in eastern Turkey between the 1 January 2018 and 31 December 2019 were included in the study by retrospective file scanning. Patients demographic datas, complaints, underlying diseases and discharge statuses were recorded and evaluated. **Results:** Of the patients hospitalized, 21.41% were admitted to our palliative care for respiratory distress, 19.31% for pain palliation, 19.36% for nutritional support, 13.81% for decubitus ulcer, and 26.11% were admitted for different complaints. Of these patients, 17.4% had cerebrovascular accident, 12.7% had Alzheimer's disease, 11% had diabetes mellitus, and its complications, 6.8% had stomach cancer, 4% lung cancer, 3.8% had pain, and the remaining 44.3% had various underlying diseases such as infectious diseases, other malignancies, post-traumatic rehabilitation and care, tetraplegia/paraplegia, different chronic diseases, etc. The discharge statuses of the patients were as follows: 22.72% passed away, 31.25% were referred to a different department, 39.58% were discharged to their home or care center, and 6.45% were still hospitalized from the beginning of 2020. **Conclusion:** Expert teams and centers are needed for the treatment, care, and rehabilitation of patients who need end-of-life and palliative care. We believe that more palliative care centers will be needed with the increase in the rates of malignant and chronic diseases in addition to the increase in the number of people requiring care.

Keywords; Palliative care, elderly population, need of care

ÖZET

Giriş: Tıbbi alanda gerçekleşen gelişmeler sonucu insanlığın ömrü ve yaşam kalitesinde olumlu yönde artışlar olmuş, bu yüzden insanların bakım ihtiyaçları giderek artmıştır. Bu çalışmada bir eğitim ve araştırma hastanesinde palyatif bakım ünitesinin çalışma usulü ve 2018-2019 yılları içerisinde palyatif bakım ünitesinde yatan hastaların retrospektif olarak değerlendirilmesi amaçlanmıştır. **Metod:** Yerel etik kurulundan alınan onay sonrası Türkiye'nin doğusunda bulunan bir eğitim ve araştırma hastanesinde geçmişe yönelik dosya taraması yolu ile 1 Ocak 2018-31 Aralık 2019 tarihleri arasında palyatif bakım merkezinde yatan hastalar çalışmaya dahil edildi. Hastaların demografik verileri, şikayetleri, altta yatan hastalıkları ve tedavinin sonunda sahip oldukları durum kaydedildi ve değerlendirildi. **Bulgular:** Yatan hastaların %21,41'i solunum sıkıntısı, %19,31'u ağrı palyasyonu, %19,36' u beslenme desteği, %13,81'ü dekübit ülseri ve %26,11'i ise farklı şikayetlerle palyatif bakım servisimize başvuru yapmışlardır. Bu hastaların %17,4'u serebrovasküler olay, %12,7'si alzheimer, %11'i diabetes mellitus ve komplikasyonları, %6,8'i mide kanseri, %4'ü akciğer kanseri, %3,8'i ağrı ve kalan %44,3'ü enfeksiyon hastalıkları, diğer maligniteler, travma sonrası rehabilitasyon ve bakım, tetrapleji/parapleji, farklı kronik hastalıklar vb gibi altta yatan farklı hastalıkları mevcuttu. Hastaların eksterne oluş halleri %22,72'si eksitus, %31,25'i farklı bir sevisse devir, %39,58'u evine veya bakım merkezine taburcu, %6,45'i ise 2020 yılı başı itibarı ile yatışı devam ediyor gözükmekte idi. **Sonuç:** Son dönem ve bakım ihtiyacı bulunan hastaların tedavi, bakım ve rehabilitasyonları için uzman ekip ve merkezlere ihtiyaç duyulmaktadır. Bakım ihtiyacı olan insan sayısının artışı sıra malignite ve kronik hastalık oranlarında yaşanan artış ile birlikte daha çok palyatif bakım merkezine ihtiyaç duyulacağını düşünmekteyiz.

Anahtar kelimeler; Palyatif bakım, yaşlı nüfus, bakım ihtiyacı

1. INTRODUCTION

As a result of the developments in the field of medicine, especially since the second half of the 20th century, there has been a positive increase in the life span and quality of life of human beings. Intensive care units have been needed more and more over time due to the prolonged life span and the need for quality care. Rapid progress has been observed in the palliative care process in countries such as Scandinavian countries, the UK, and Canada since the beginning of the 1990s (1). The studies started in 2008 in our country accelerated especially in the 2010s (2). According to the data from the Turkey Statistical Institute, the rate of population aged 65 years and over is increased to 8.74% as of 2018, and this result showed that the population in need of care has gradually increased (3). Moreover, with this result, prolonged hospitalizations occurred day by day in current intensive care units, and both material and moral losses have occurred with the broad hospitalization indications. (4)

The World Health Organization (WHO) defined palliative care as an approach that improves the quality of life of patients and their families facing the problem associated with life-threatening diseases, through the prevention and relief of pain and other problems utilizing physical, psychosocial, and spiritual treatment. This definition also involves attempts to predict potential adverse events before they occur and to implement measures. (5,6) In 1967, Cicely Saunders proposed the idea of "hospice" for people who needed medical and social care and who were in their terminal period, and with the spread of this idea, palliative care units have started to be opened in hospitals worldwide. The first article of the directive on the implementation of procedures and principles of palliative care services issued by the Ministry of Health of the Republic of Turkey in 2014 defined palliative care as "early identification and assessment of pain and other symptoms in patients encountering problems associated with life-threatening diseases, and to relieve or prevent their pain by providing medical, psychological, social, and spiritual support to these patients and their families to improve their quality of life", which paved the way to accelerate palliative care services and to assess these services within the scope of insurance in Turkey. (7)

This study also aimed to retrospectively evaluate the working principle of the palliative care unit in a training and research hospital in eastern Turkey, which served as a center for the region, and the patients hospitalized in the palliative care unit between 2018-2019.

2. METHODS

After obtaining approval from the local ethics committee, patients hospitalized in the palliative care center of a training and research hospital in eastern Turkey between 1 January 2018-31 December 2019 were included in the study by retrospective file scanning. The demographic data, length of hospital stay, admission complaints, underlying chronic diseases and treatment outcomes of the patients were analyzed through the electronic information management system of the hospital and archive data. Patients with incomplete file information and repeated hospitalizations with the same symptoms and complaints were excluded from the study.

3. RESULTS

This study included a total of 528 adult patients. Of these patients, 50.6% were female, and 49.4% were male. The mean age of female patients was 75.71 ± 12.681 years, the mean age of male patients was 72.06 ± 15.47 years, while age of all patients were $73, 91 \pm 14,29$ years. The length of hospital stay was 28.51 ± 33.91 days in the female patients, 37.63 ± 64.81 days in the male patients and $32, 84 \pm 51,59$ days in all patients. Of a total of 528 patients hospitalized, a total of 2 patients were from abroad; one of them was Syrian, and the other one was Madagascanian (Table 1).

Table 1: Evaluation of demographic data of patients.

Age	73, 91 \pm 14,29 [18-100]
Gender (Female/Male)	267 (%50.6) / 261 (%49,4)
Duration of hospitalization days	32, 84 \pm 51,59 [1-794]
Nationality (Turkey/Syria/Madagascar)	526/1/1

Values were expressed mean \pm standart deviation or number.

Of the patients hospitalized, 21.41% were admitted to our palliative care for respiratory distress, 19.36% for pain palliation, 19.31% for nutritional support, 13.81% for decubitus ulcer, and 26.11% were admitted for different complaints. Of these patients, 17.4% had cerebrovascular accident, 12.7% had Alzheimer's disease, 11% had diabetes mellitus, and its complications, 6.8% had stomach cancer, 4% lung cancer, 3.8% had pain, and the remaining 44.3% had various underlying diseases such as infectious diseases, other malignancies, post-traumatic rehabilitation and care, tetraplegia/paraplegia, different chronic diseases, etc (Graphic 1-2).

The discharge statuses of the patients were as follows: 22.72% passed away, 31.25% were referred to a different department, 39.58% were discharged to their home or care center, and 6.45% were still hospitalized from the beginning of 2020 (Graphic 3).

Graphic 1: Complaints of patients hospitalized in palliative care service in admission.

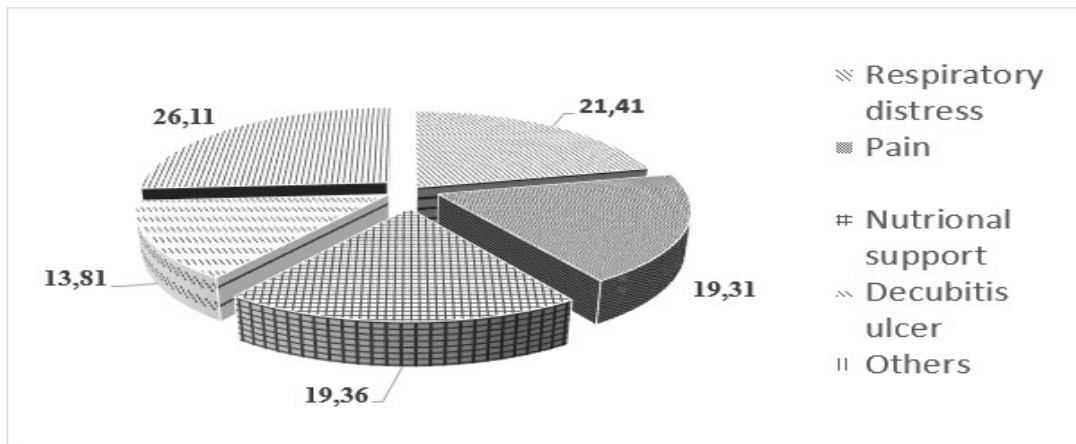

Graphic 2: Existing chronic diseases of patients in palliative care unit in admission.

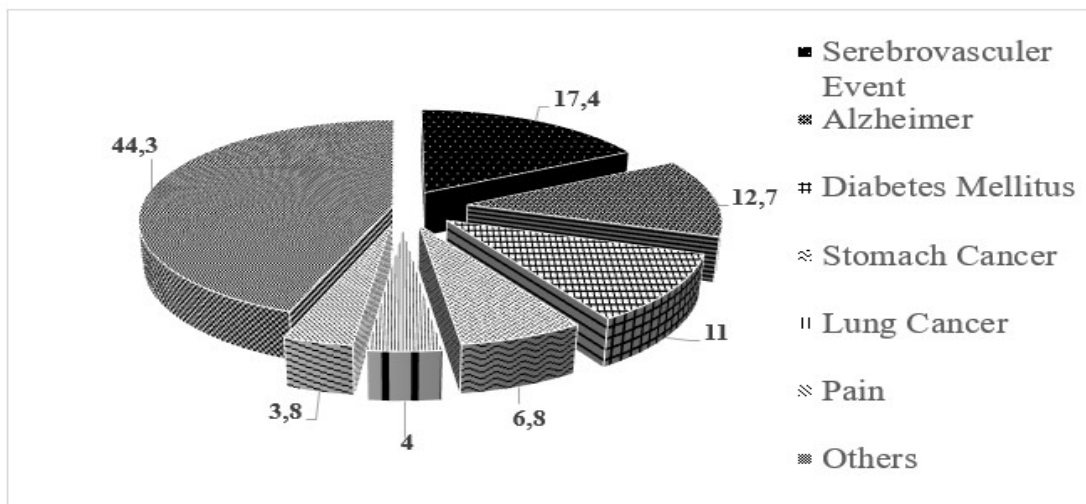

Graphic 3: End of the status of patients in palliative care unit.

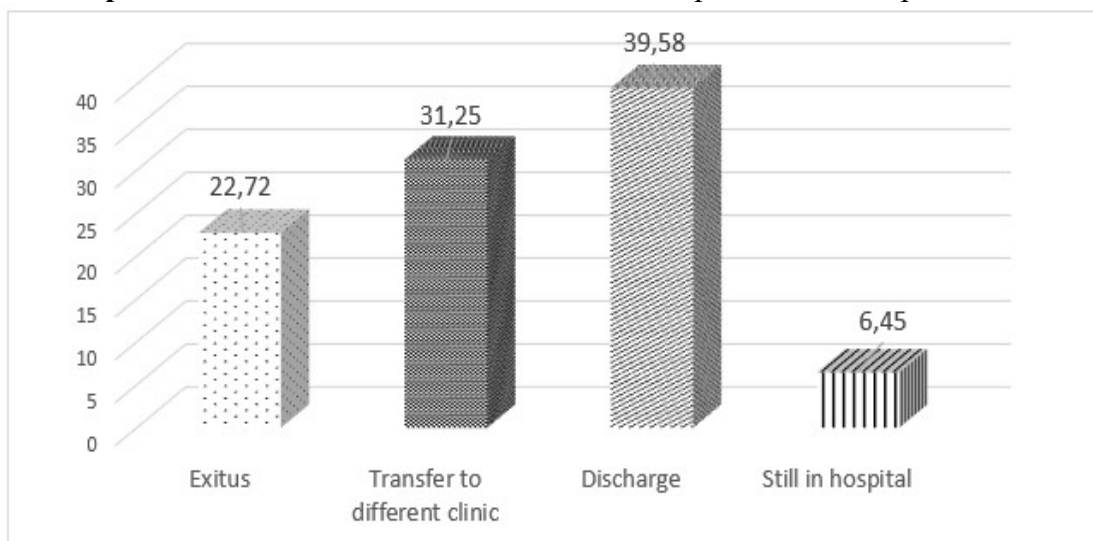

4. DISCUSSION

Today, the improvement of patient and elderly care along with the prolonged life span resulted in a population in need of longer care and support. Especially in our country, there is an increase in the number of patients from every age group who have a poor general condition, who need self-care, and who cannot be discharged from intensive care units to perform their care after intensive care treatment. For this purpose, home healthcare units and palliative care centers have been established in the world and our country, allowing the required to be provided outside the intensive care units. (4, 8)

Contrary to a general perception in the community, palliative care centers do not only serve individuals who are considered to be elderly and in need of care. All populations of young and elderly people with poor self-care, in need of rehabilitation or terminal period, are within the scope of palliative care center (1). Compared to the age values of other palliative care centers in our country, our palliative care unit has served a similar age group of patients. The youngest of the patients who were admitted to our clinic in 2018-2019 was 18 years old, while the oldest patient was 100 years old. Although the mean gender of different centers in Turkey is predominantly female, our clinic has nearly equal proportions of genders (5, 9).

The most common complaints of admission to our palliative care center were other reasons (dressing, aspiration requirement, physical therapy requirement, etc.), respiratory support, pain palliation, nutritional support, and decubitus ulcer/wounds. In addition to these diagnoses, cerebrovascular event, Alzheimer's disease, diabetes mellitus, and its complications, stomach cancer, lung cancer, pain and infectious diseases, other malignancies, post-traumatic rehabilitation and care, tetraplegia/paraplegia and Parkinson's disease, epilepsy, heart failure, etc. were the most common reasons for the patients' admissions on a chronic basis.

Even though the palliative care center outpatient clinic, family physicians and homecare centers mediate the admission process to the palliative centers, some of the admissions are from the emergency clinics. A study conducted in a training and research hospital in Istanbul found malnutrition, pain, poor general condition, percutaneous enterogastrostomy cannula problems, respiratory distress, etc. and underlying malignancy, neurological disorders, cardiac problems, the underlying diseases

such as COPD, etc. as the most common indications for admission and hospitalization, as in our clinic (10). The rate of the patients diagnosed with end-stage malignancy and hospitalized in our palliative care unit was 25.9%. This rate is found to be similar to the rates of some palliative care centers located in different regions of Turkey (9). All the primary and paraneoplastic problems caused by malignancy constitute the reason for this increased hospitalization rate. Although the general opinion for this period is "*Any initiative will not help*", the need for patients for healthcare professionals increases after a certain stage due to nutrition disorders, pain and hemodynamic instability (11). In brief, this period can be summarized as a period that patients and their relatives should spend together with the recommendations of health professionals. The care and support training is provided to relatives of patients in need of care in our palliative care center as long as they are by their side. The rehabilitation process of the patient and their relatives is accelerated with this care, and the patient can be discharged when the physician deems it appropriate, and their care can easily be provided by their relatives who have the necessary training. For these reasons, the mean length of stay in our palliative care center is 32.84 ± 51.59 days. The researchers showed the mean length of stay as 15 and 45 days in two different studies conducted in Turkey, respectively. (12) In another study conducted abroad, the researchers showed the mean length of stay as 14 days. (13) These number of hospitalization days show that there is no standard length of stay in palliative care units and the length of stay can be determined by the preferences of the palliative care center and the medical, as well as social needs of patients. A certain period of training is necessary for the patient's relative to be able to carry out home care, assimilate the care process and perform interventions easily in patients groups desired to be provided home care.

Our palliative care center in our hospital mostly admitted patients from the eastern Anatolia region due to its location in eastern Turkey. During this period, our center served not only Turkish citizens but also foreign citizens such as Syria (1 patient) and Madagascar (1 patient), albeit only a small number. The number of studies in the literature on care rates for foreign patients is limited. The result we obtained in our clinic is that the rate of foreign patient admissions is low. It appears that palliative care units are an issue that should be emphasized and taken care of for health tourism, which has attracted increasing interest in public hospitals in our country, especially recently.

In this study, the data of a successful palliative care center of a training and research hospital located in the east of Turkey were presented. With many palliative

care centers, such as our palliative care center, the treatment, care and rehabilitation of patients who need end-of-life and palliative care are performed, and we believe that more palliative care centers will be needed with the increase in the rates of malignant and chronic diseases in addition to the increase in the number of the population requiring care.

Conflict of Interest: The authors declare that no conflict of interest.

Funding: None.

REFERENCES

1. Bağ B. Almanya örneğinde sağlık sisteminde palyatif bakım uygulamaları. *Türk Onkoloji Dergisi*, 2012;27(3):142-9.
2. Kabalak AA. Türkiye'de Palyatif bakım çalışmaları-Palyatif Bakım Kavramına Çok Yönlü Bakış Özel Sayısı. *Türkiye Klinikleri J Anest Reanim-Special Topics*, 2017;10(1):7-12.
3. Yaşlı nüfus sayımı TİKv, 2019. Erişim adresi: <http://www.tuik.gov.tr/HbGetirHTML.do?id=33705>
4. Akpınar A, Alvur M. Palyatif Bakımda Etik ve Medikolegal Yaklaşım. *Türkiye Klinikleri, J Fam Med-Special Topics*. 2017;8(4):292-8.
5. Benli AR, Sunay D. Palyatif Bakım Merkezi ve Evde Sağlık Hizmetlerinin Birlikte Çalışması Örneği: Karabük. *Ankara Med J*, 2017(3):143-50.
6. World Health Organisation, 2020. Erişim adresi: <https://www.who.int/cancer/palliative/definition/en/>
7. T.C. Sağlık Bakanlığı Palyatif Bakım Merkezleri, 2020. Erişim adresi: <https://khgmozellikli.saglik.gov.tr/svg/palyatif.php>
8. Kart L, Akkoyunlu ME, Akkoyunlu Y, Sezer M, Özçelik HK, Karaköse F, et al. Yoğun bakım ünitesinde yatan Son Dönem Hastaların Değerlendirilmesi. *Selçuk Üniv Tıp Derg*, 2011(3):146-8.
9. Komaç A, Elyiğit F, Türemiş C, Gram E, Akar H. Tepecik Eğitim ve Araştırma Hastanesi İç Hastalıkları Palyatif Bakım Ünitesi'nde yatan hastaların retrospektif analizi. *FNG & Bilim Tıp Dergisi*, 2016;2(1):1-3.
10. Tekyol D, Altundağ İ, Hökenek NM, Akman G. Evaluation of palliative care patients admitted to emergency department. *Haydarpaşa Numune Medical Journal*, 2019;59(4):333-336.
11. Yavuzşen T, Kömürcü Ş. Kanser hastalarında halsizlik semptomunun değerlendirilmesi ve birlikte görülen klinik problemler. *Gülhane Tıp Dergisi*, 2008;2(50):141-6.
12. Benli AR, Sunay D. Palyatif Bakım Merkezi ve Evde Sağlık Hizmetlerinin Birlikte Çalışması Örneği: Karabük. *Ankara Med J*, 2017;(3):143-50.
13. Alsirafy SA, Hassan AA, Al-Shahri MZ. Hospitalization pattern in a hospital-based palliative care program: an example from Saudi Arabia. *The American journal of hospice & palliative care*. 2009;26(1):52-6.