

## SUBSTRATE INTEGRATED WAVEGUIDE BAND-PASS FILTER WITH CPWG FED FOR RADAR APPLICATION IN X-BAND

Abbas AYARAN<sup>1</sup>, J. Bagheri K.<sup>2</sup>, S. GOLMOHAMMADI<sup>3</sup>

<sup>1</sup> Department of electrical engineering, East Azarbaijan Science and Research Branch, Islamic Azad University, Tabriz, Iran. ([ayaran.ieee@yahoo.com](mailto:ayaran.ieee@yahoo.com))

<sup>2</sup> Department of electrical engineering, East Azarbaijan Science and Research Branch, Islamic Azad University, Tabriz, Iran. ([moghaddas74@yahoo.com](mailto:moghaddas74@yahoo.com))

<sup>3</sup> Department of electrical engineering, East Azarbaijan Science and Research Branch, Islamic Azad University, Tabriz, Iran. ([sgolmohmmadi@tabrizu.ac.ir](mailto:sgolmohmmadi@tabrizu.ac.ir))

**Abstract:** Filter described in this paper is composed of two cavity resonator that formed by substrate integrated waveguide (SIW). The filter is fed by coplanar waveguide with ground (CPWG) that provide 50 ohm input impedance in proposed filter. The proposed filter bandwidth is from 8.6 to 9.2 GHz that this region of frequency have  $S_{21} > -3\text{dB}$  and  $S_{11} < -10\text{dB}$ .

### INTRODUCTION:

Radio Frequency (RF) filters possess the properties of frequency-selective transmission allowing energy to transmit desirable bandwidths (passbands) and attenuate undesirable bandwidths (stopbands). These microwave filters are essential components for the front-end of today's communication systems. The current progression of wireless communication technologies demand RF front-end designs to have better performance, lower power, and a more compact size. Conventional non-planar structures such as the rectangular waveguide possess the advantage of producing higher performing filters compared to planar configurations due to their lower loss characteristics. However, advantages of planar structures such as microstrip and coplanar waveguide (CPW) filters relate to a more compact size and lower manufacturing cost. The substrate integrated waveguide (SIW) has recently been developed to fill this performance gap by possessing the advantages of both types of structures [1]. The basic concept of the SIW merges waveguide cavities with planar structures on a single dielectric high frequency material. This is accomplished through rows of vias in a substrate dielectric acting as the walls of a waveguide cavity. The top and bottom metal layers of the high frequency PCB material next form the upper and lower cavity walls, while planar transmission lines provide RF input/output [2]. Tapered transition regions are then placed between the planar transmission lines and the top metal layer of each cavity, completing the SIW structure [3]. Many applications are attributed to the use of SIW structures. Depending on the configuration, the SIW has been utilized for antenna arrays [5]-[8] and slot antennas [9]-[11]. For RF circuit applications, proper adjustment to the dimensions of SIW transmission waveguides enable the development of various linear phase shifters [12]-[13]. Additionally, directional couplers [14]-[16], power divider/combiners [17]-[19], and mixers/oscillators [20]-[22], all have been realized through the use of different configurations of multiple SIW cavities. The most researched application of the SIW involves filter design. Various designs have been

implemented to help reduce the size of SIW filters even further including folded substrate integrated waveguide (FSIW) [23]-[24], half-mode substrate integrated waveguide (HSIW)[25], and evanescent-mode SIW filters [26]-[27]. In addition, SIW cavities have been employed to produce higher quality filters compared to planar configurations such as dual-mode SIW filters [29]-[30], compact super-wide bandpass filters [31], and multilayered

substrate integrated waveguide (MSIW) filters [32]. Lastly, complete front-end systems regarded as system-in/on-package (SiP/SoP) designs have recently been developed with SIW structures such as an X-band receiver with embedded MSIW filters [33] or a 60 GHz multi-chip module receiver Chaving both an SIW antenna and an SIW filter all on one substrate [34].

In this paper with using tow cavity resonator that made by substrate integrated waveguide will presented. To feeding each resonators of proposed filter are used of coplanar waveguide with ground. The cavity resonators are placed in over together and coupling between to resonator is helped with a slot.

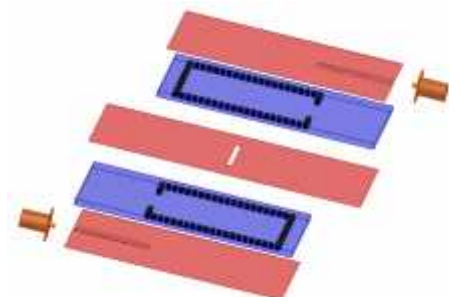

(a)

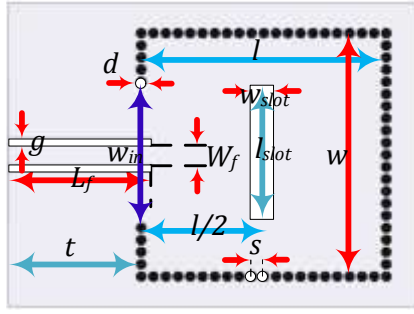

(b)

**Figure 1.** Configuration of proposed bandpass filter a) multilayered view b) cavity resonator with parameters ( $d=0.5$ ,  $s=0.6$ ,  $W_f=1$ ,  $g=0.3$ ,  $w=12$ ,  $l=12$ ,  $w_{slot}=0.8$ ,  $l_{slot}=9$ ,  $L_f=7$ ,  $t=6$  and  $w_{in}=7.2$ ; all unit are mm)

### Filter Parameters & Structure:

The filter has been designed on Rogers 4003 with electrical permittivity  $\epsilon_r=3.55$  and loss tangent  $\tan\sigma=0.002$ , the thickness of substrate is  $h=0.524$ mm.

The Filter is composed of two layers, one of layer over another layer is placed. Each layer is composed of a coplanar waveguide with ground (CPWG). In order to achieve 50 ohm impedance feed line use from CPWG with  $W=1$ mm and  $g=0.3$ mm. Each layer have a cavity resonator with  $12 \times 12$  mm<sup>2</sup>. Between two layers of substrate in metal of between two layers a slot with length of  $\lambda_g/2 \cong 9$  mm and width of  $\lambda_g/20 \cong .8$  mm is embedded. Other parameters are shown in figure 1.

### Result and discussion:

Substrate Integrated Waveguide (SIW) cavities follow the same basic principles compared to conventional air-cavity rectangular waveguides. Some key differences relate to the dissimilar dielectrics of air versus a substrate material. More care must be taken in order to design SIW cavities for microwave applications. This is due to higher frequencies being more sensitive to substrate losses versus a very low loss air dielectric. Additionally, compared to conventional 3-D rectangular waveguides, thinner substrate dielectrics prevent Transverse Magnetic (TM) modes to resonate. Therefore, only Transverse Electric (TE) modes can effectively propagate through SIW cavities [28].

Given the above distinctions, two primary design rules for SIW cavities are next presented in order to exploit the same modeling and design procedures for conventional waveguides. These rules pertain to the diameter ( $d$ ) of the metal via posts emulating the waveguide side walls and the via post spacing ( $s$ ) [22-23]:

$$d < \lambda_g/5 \quad 1(a)$$

$$s \leq 4d \quad 1(b)$$

Disregarding these expressions creates too much leakage loss for the via post SIW cavity side walls to perform as conventional rectangular waveguide side walls. Figure 1(b) depicts a single SIW cavity resonator with appropriately labeled dimensions. Metal layers 1 and 2 create the top and

bottom terminations of the waveguide with via posts generating the side wall terminations of the waveguide. The following expressions provide the first resonant frequency mode for the SIW cavity [31]:

$$f = \frac{c}{2\pi\sqrt{\mu_r\epsilon_r}} \sqrt{\left(\frac{\pi}{w_{eff}}\right)^2 + \left(\frac{\pi}{l_{eff}}\right)^2} \quad 2(a)$$

$$l_{eff} = l - \frac{d^2}{0.95b}, w_{eff} = w - \frac{d^2}{0.95b} \quad 2(b)$$

where  $f$  is the first resonant mode of the cavity,  $w$  and  $l$  are the width and length of a single SIW cavity,  $d$  is the diameter of the vias, and  $s$  is the via spacing (depicted in Figure 1(b)). The expressions are only valid when equations 2(a) and 2(b) are upheld, enabling the via posts to function as conventional rectangular waveguide side walls. These single SIW cavity resonator dimensions are the basis for the two-pole fixed filter design. Adjusting the dimensions of these coupling window openings in the SIW cavities provides the tuning needed to match coupling coefficients and external quality factors extracted from full-wave simulation to the calculated parameters.

Figure 2 depicts the return loss and insertion loss of the bandpass filter, shown in Figures 1(a) and 1(b), developed in this article. As show in figure 2 the pass band of proposed filter is from 8.6 GHz to 9.2 GHz and minimum point of  $S_{11}$  is placed in 8.8 GHz with -30dB depth. Figure 3 shows the contour map for the electric field distribution in the two cavities. The polarization of the electric field drawn in this figure is along the  $z$ -direction. In Figure 3, the operation frequency is 8.8 GHz. From this figure, we may clearly see that the resonant mode in both cavities is  $TM_{110}$ ; the maximum field strength takes place around the middle of the cavity. Since the aperture is opened at the position near the maximum electric field, the energy can be significantly coupled from the first cavity to the second one.

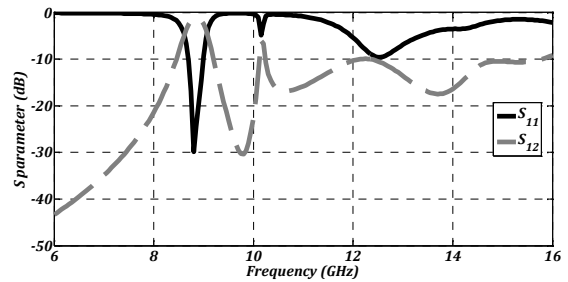

**Figure 2.** Return loss and insertion loss of the bandpass filter

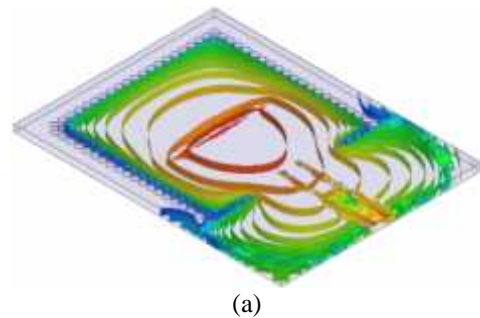

(a)

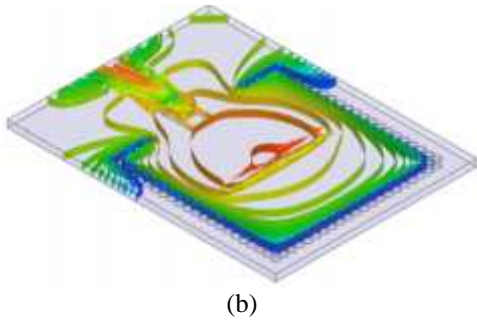

**Figure 3.** Contour map for the electric field distribution in the two cavities a)top layer b)bottom layer

## CONCLUSION:

On roger 4003 was designed a bandpass filter with tow cavity resonator. The cavity of resonator was consisted of substrate integrated waveguide that the side walls of SIW has been evoked the waveguide with high quality factor. The input of cavity resonator is fed by 50 ohm input impedance with CPWG feed line. Coupling between two cavity resonators have been occurred by a slot with length of  $\lambda_g/2$  which this slot was matched with resonator frequency and defined bandwidth of proposed filter. The filter has bandwidth frequency from 8.6 to 9.2 GHz.

## Reference

- [1] K. Wu, "Substrate integrated circuits (SIC) and systems for RF and millimeter wave applications," *38th European Microwave Conference*, presentation, Amsterdam, Netherlands, Oct. 2008.
- [2] D. Deslandes, K. Wu "Single-substrate integration technique of planar circuits and waveguide filters," *IEEE Transactions on Microwave Theory and Techniques*, vol. 51, no. 2, pp. 593-596, Feb. 2003.
- [3] Z. Hao, W. Hong, H. Li, H. Zang, "A broadband substrate integrated waveguide (SIW) filter," *IEEE Antennas and Propagation Society International Symposium*, vol. 1B, pp. 598-601, 2005.
- [4] D. Deslandes, K. Wu, "Integrated microstrip and rectangular waveguide in planar form," *IEEE Microwave and Wireless Components Letters*, vol. 11 no. 2, pp. 68-70, Feb. 2001.
- [5] M. Henry, C. E. Free, B. Izqueirdo, J. Batchelor, P. Young, "Millimetre wave substrate integrated waveguide antennas: design and fabrication analysis," *IEEE Transactions on Advanced Packaging*, vol. 32, no. 1, Feb. 2009.
- [6] S. Lin, S. Yang, A. E. Fathy, "Development of a novel UWB vivaldi antenna array using SIW technology," *Progress In Electromagnetics Research*, vol. 90, pp. 369-384, 2009.
- [7] S. Yang, E. Adel, S. Lin, A. E. Fathy, A. Kamel, and H. Elhennawy, "A highly efficient Vivaldi antenna array design on thick substrate and fed by SIW structure with integrated GCPW feed," *2007 IEEE Antennas and Propagation Society International Symposium*, pp. 1985-1988, 2007.
- [8] S. Yang, A. E. Fathy, "Development of a slotted substrate integrated waveguide (SIW) array antennas for mobile DBS application," *Antenna Applications Symposium*, pp. 101-131, Chicago IL, 2006.
- [9] D. Stephens, P. R. Young, I. D. Robertson, "W-band substrate integrated waveguide slot antenna," *Electronic Letters*, vol. 41, no. 4, Feb. 2005.
- [10] A. J. Farrall, P. R. Young, "Integrated waveguide slot antennas," *Electronic Letters*, vol. 40, no. 16, pp. 974-975, Aug. 2004.
- [11] L. Yan, W. Hong, G. Hua, J. Chen, K. Wu and T. J. Cui, "Simulation and experiment on SIW slot array antennas," *IEEE Microwave Wireless Components Letters*, vol. 14, no. 9, pp. 446-448, Sep. 2004.
- [12] X. P. Chen, W. Hong, T. Cui, J. X. Chen, and K. Wu, "Substrate integrated waveguide (SIW) linear phase filter," *IEEE Microwave and Wireless Components Letters*, vol. 15, no. 11, pp. 787-789, Nov. 2005.
- [13] W. Q. Che, E. K. N. Yung, K. Wu, X. D. Nie, "Design investigation on millimeter-wave ferrite phase shifter in substrate integrated waveguide," *Progress In Electromagnetics Research*, vol. 45, pp. 263-275, 2004.
- [14] V. A. Labay, J. Bornemann, T. R. Rao, "Design of multilayered substrate integrated waveguide cross-slot couplers," *39th European Microwave Conference*, pp. 409-412, Sep. 2009.
- [15] V.A. Labay and J. Bornemann, "E-Plane directional couplers in substrate integrated waveguide technology," *Proceedings Asia-Pacific Microwave Conference*, Hong Kong, Dec. 2008.
- [16] Y. Cassivi, D. Deslandes, and K. Wu, "Substrate integrated waveguide directional couplers," *Proceedings Asia Pacific Microwave Conference*, presentation, Kyoto, Japan, Nov. 2002.
- [17] K. Song, Y. Fan, and Y. Zhang, "Design of low-profile millimeterwave substrate integrated waveguide power divider/combiner," *International Journal of Infrared Millimeter Waves*, vol. 28, no. 6, pp. 473-478, 2007.
- [18] S. Germain, D. Deslandes, and K. Wu, "Development of substrate integrated waveguide power dividers," in *Proceedings IEEE Canadian Conference Electrical and Computer Engineering*, vol. 3, pp. 1921-1924, May 2003.
- [19] Z. C. Hao, W. Hong, and K. Wu, "Multi-way broad-band substrate integrated waveguide (SIW) power divider," *Proceedings IEEE International Symposium Antennas Propagation*, pp. 639-642. Washington, DC, Jul. 2005.
- [20] J. Chen, W. Hong, Z. Hao, H. Li, K. Wu, "Development of a low cost microwave mixer using a broad-band substrate integrated waveguide coupler," *IEEE Microwave and Wireless Components Letters*, vol. 16, no. 2, Feb. 2006.
- [21] Y. Cassivi and K. Wu, "Lowcost microwave oscillator using substrate integrated waveguide cavity,"

*IEEE Microwave and Wireless Components Letters*, vol. 13, no. 2, pp. 48–50, Feb. 2003.

[21] J. Xu, K. Wu, “A subharmonic self-oscillating mixer using substrate integrated waveguide cavity for millimeter-wave application,” *Microwave Symposium Digest, 2005 IEEE MTT-S International*, pp. 12–17, June 2005.

[22] L. S. Wu, R. Wang, X. L. Zhou, “Compact folded substrate integrated waveguide cavities and bandpass filter,” *Progress In Electromagnetics Research*, vol. 84, pp. 135–147, 2008.

[23] Z. Hao, W. Hong, X. P. Chen, J. X. Chen, K. Wu, “A single-layer folded substrate integrated filter,” *Asia Pacific Microwave Conference*, vol. 1, p. 3 ff, 2005.

[24] Y. Wang, W. Hong, Y. Dong, B. Liu, H. J. Tang, J. Chen, X. Yin, K. Wu, “Half mode substrate integrated waveguide (HMSIW) bandpass filter,” *IEEE Microwave and Wireless Components Letters*, vol. 17, no. 4, pp. 265–267, Apr. 2007.

[25] T. Shen, K. A. Zaki, “Length reduction of evanescent-mode ridge waveguide bandpass filters,” *Progress In Electromagnetics Research*, vol. 40, pp. 71–90, 2003.

[26] N. Molanian, G. R. Solat, P. Parvand, “A novel HPF of substrate integrated waveguide,” *International Journal of Computer Science and Network Security*, vol. 8, no. 10, pp. 230–235. Oct. 2008.

[27] X. P. Chen, W. Hong, T. J. Cui, Z. C. Hao, K. Wu, “Symmetric dual-mode filters based on substrate integrated waveguide (SIW),” *Electr Eng.*, vol. 89, pp. 67–70. 2006.

[28] X.-P. Chen, K. Wu and Z.-L. Li, “Dual-band and triple-band substrate integrated waveguide filters with Chebyshev and quasi-elliptic responses”, *IEEE Transactions on Microwave Theory and Techniques*, vol 55, pp. 2569–2578, Dec. 2007.

[29] Z. C. Hao, W. Hong, J. X. Chen, X. P. Chen, and K. Wu, “Compact super-wide bandpass substrate integrated waveguide (SIW) filters,” *IEEE Transactions on Microwave Theory and Techniques*, vol. 53, no. 9, 2968–2977, Sept. 2005.

[30] Z. C. Hao, W. Hong, J. X. Chen, X. P. Chen, J. X. Chen, K. Wu, and T. J. Cui, “Multilayered substrate integrated waveguide (MSIW) elliptic filter,” *IEEE Microwave and Wireless Components Letters*, Vol. 15, No. 2, 95–97, Feb. 2005.

[31] J. Chen, W. Hong, X. Chen, P. Yan, Q. Lai, K. Wu, “An LTCC X-band receiver front-end using embedded multilayer substrate integrated waveguide filter,” *Microwave Optics Technology Letters*, vol. 50, pp. 285–287, 2008.

[32] K.K. Samanta, D. Stephens, I.D. Robertson, 60 GHz multi-chip module receiver with substrate integrated waveguide antenna and filter, *Electronics Letters*, vol. 42, pp. 701–702, 2006.