



Position Control of Slider-Crank Mechanism

Muhammet Aydın^{1*}

^{1*} Firat University, Faculty of Engineering, Department of Mechatronics, Elazığ, Turkey, (ORCID: 0000-0003-2746-9477), muhammeta@firat.edu.tr

(2nd International Conference on Engineering and Applied Natural Sciences ICEANS 2022, October 15 - 18, 2022)

(DOI: 10.31590/ejosat.1184248)

ATIF/REFERENCE: Aydın, M. (2022). Position Control of Slider-Crank Mechanism. *European Journal of Science and Technology*, (42), 158-162.

Abstract

This paper presents the position control of the slider-crank mechanism in the simulation environment. The slider-crank mechanism was first 3D modeled in the Solidworks environment. This model was afterwards converted to xml format. The slider-crank mechanism's simulink blocks were made using the xml file from the Matlab model, which allowed the 3D model to be imported into Matlab. These Simulink blocks were used to implement the PID control approach for angle control of the model's input limb. In order to achieve this purpose, additional blocks required from the simulink have been added to other existing blocks. It has been determined that the mechanism's target reference point rotates 90 degrees in 0.01367 seconds. It was discovered that the error value was 0.03114. It is evident from the results that the mechanism's PID control method allows for quick position control with a very tiny margin of error. Solidworks is a program that may be used to create the final design of the slider-crank mechanism that will be created using this method. By deciding on the material that will be used to make the mechanism, it is simpler to achieve adequate control coefficients for practical applications when the same operations are repeated. This will free up time for additional study.

Keywords: Position control, Slider-Crank, Mechanism control, Simmechanics, Modeling.

Krank Biyel Mekanizmasının Pozisyon Kontrolü

Öz

Bu makale, simülasyon ortamında krank biyel mekanizmasının konum kontrolünü sunmaktadır. Krank biyel mekanizması ilk olarak Solidworks ortamında 3B modellenmiştir. Bu model daha sonra xml formatına dönüştürülmüştür. Krank biyel mekanizmasının simulink blokları, Matlab modelinden xml dosyası kullanılarak yapıldı ve bu, 3B modelin Matlab'a aktarılmasına izin verdi. Bu Simulink blokları, modelin giriş uzvunun açı kontrolü için PID kontrol yaklaşımını uygulamak için kullanıldı. Bu amaca ulaşmak için mevcut diğer bloklara simulinkten gerekli ek bloklar eklenmiştir. Mekanizmanın hedef referans noktasının 0.01367 saniyede 90 dereceye ulaştığı elde edilmiştir. Hata değerinin ise 0.03114 olduğu tespit edildi. Mekanizmanın PID kontrol yönteminin çok küçük bir hata payı ile hızlı pozisyon kontrolüne izin verdiği sonuçlardan açıkça görülmektedir. Solidworks, bu yöntemle oluşturulacak krank biyel mekanizmasının son tasarımını oluşturmak için kullanılacak bir programdır. Mekanizmayı yapmak için kullanılacak malzemeye karar vererek, aynı işlemler tekrarlandığında pratik uygulamalar için yeterli kontrol katsayılarına ulaşmak daha kolaydır. Bu işlem ek çalışma için zaman kazandıracaktır.

Anahtar Kelimeler: Konum kontrolü, Krank-Biyel, Mekanizma kontrolü, Simmechanics, Modelleme.

* Corresponding Author: muhammeta@firat.edu.tr

1. Introduction

Mechanisms are devices that allow for the transfer of movement and change one type of movement into another. In many areas nowadays, mechanisms are used. The crank-connecting rod mechanism is one of the systems that finds widespread use. Internal combustion engines often use a crank connecting rod mechanism to convert translational movement to rotational movement, while pumps and compressors typically use a crank connecting rod mechanism to convert rotational movement to translational movement.

In the literature studies carried out so far, the position control of the crank-connecting rod mechanism is made by using the PID controller optimized with the Ziegler Nichols Method [1], the position control of the crank-connecting rod mechanism is carried out with the sliding mode controller and its dynamics are examined [2], proposed of a fuzzy mesh structure for the position control of the crank-connecting rod mechanism [3], the position control of the crank-connecting rod mechanism is made using PID fuzzy control [4], a genetic algorithm-based CTC system is proposed for the position control of the crank-connecting rod mechanism used in the ship propeller [5], the crankshaft using adaptive calculated torque technique -the position of the connecting rod mechanism is controlled [6], the output of the crank-connecting rod mechanism is connected to a pendulum, its control and dynamics are examined [7], the collective parameter approach is preferred, the dynamic behavior of the crank-connecting rod mechanism is modeled with a driving force applied in the crank-pin center, and compared in real time [8], optimum values of crank-connecting rod length were investigated for cutting multi-layered materials [9], an experienced self-adjusting PID control method was proposed for the position control of the crank-connecting mechanism [10], constant speed control to the crank-connecting rod mechanism is recommended for machine tools [11], the crank-connecting rod mechanism is used for the climbing part of the mast climbing robot [12], the crank-connecting rod is proposed as a part of the resonance control unit in the power output system [13], A self-adjusting control method based on generalized minimum variance control is proposed for the rotational speed control of the crank-connecting rod mechanism [14], crank-connecting rod is used in vibrating olive harvesters [15], crank-connecting rod is used in pressing [16], to design task space controllers for crank-connecting rod without using mechanism dynamics and linearization methods in which a new method is proposed [17] are available.

In this study, first of all, the crank-connecting rod mechanism was designed as three-dimensional using Solidworks solid modeling program. The generated crank-connecting rod mechanism was transferred from Solidworks program to Simmechanics. By using the blocks of the automatically formed mechanism, the position control of the input part of the mechanism was carried out with the PID control method.

2. Material and Method

2.1. The Slider-Crank Mechanism in Three Dimensional: Getting a Model

The Solidworks solid modeling program was used to design the slider-crank mechanism in three dimensions, which will be positioned using the PID approach. Four rotating sections were created specifically for this use. The other three movable rods have also been designed because the initial member of the slider-crank mechanism is the fixed element. By integrating the rods with the components that will allow for rotation, the solid model of the slider-crank mechanism was created. The entrance limb was moved to see if the mechanism was functional, and it was noted that the other limbs also moved.

2.2. Converting the Solid Model of the Slider-Crank Mechanism for Simulation

First, the slider-crank mechanism's xml file had to be constructed by exporting it from Solidworks in order to be imported into Matlab/Simmechanics as a solid model. Writing the xml file generated by the smimport command on the Matlab main command line resulted in the creation of the mechanism's Simulink blocks. The slider-crank system has been imported into Matlab, as shown in Fig. 1. The Simmechanics simulink blocks, which are created when employing the solid model of the mechanism, are also depicted in Fig. 2.

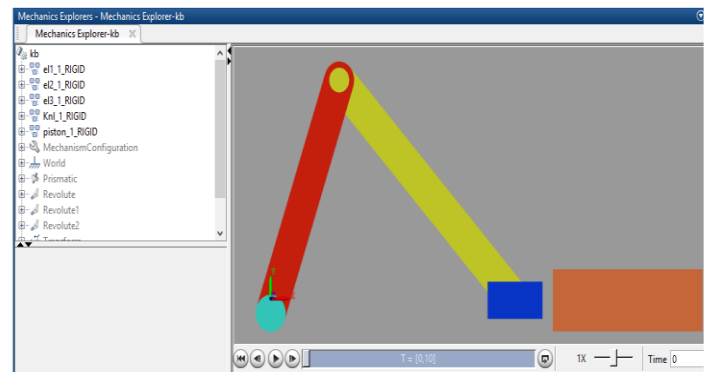

Fig. 1 Slider-Crank mechanism transferred to the Matlab

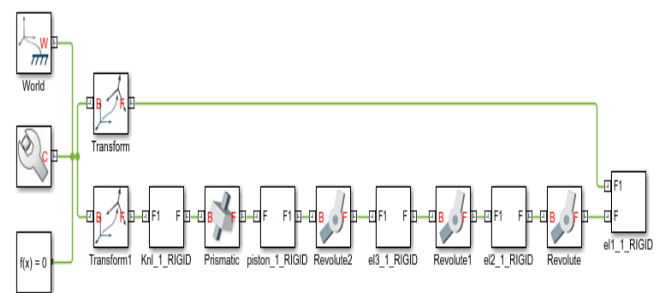

Fig. 2 Simulink blocks of slider crank mechanism

2.3. PID Control of Slider-Crank Mechanism

The mechanism that generates Simulink blocks in the blocks necessary to carry out position control in Simmechanics is added as the first step in the PID control phase. Controlling the placement of the other components of the mechanism entails

checking the position of the input member, or the portion of the mechanism where the motor is located. Only the position control of the entering limb was created because the mechanism only has one degree of freedom. The block diagram for the mechanism's PID control is shown in Fig. 3.

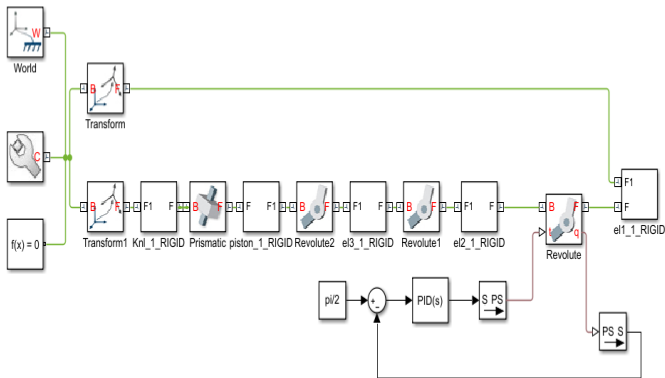

Fig. 3 Block diagram of mechanism with PID

The PID gain coefficients that were determined by calculations on the block model are shown in Fig. 4.

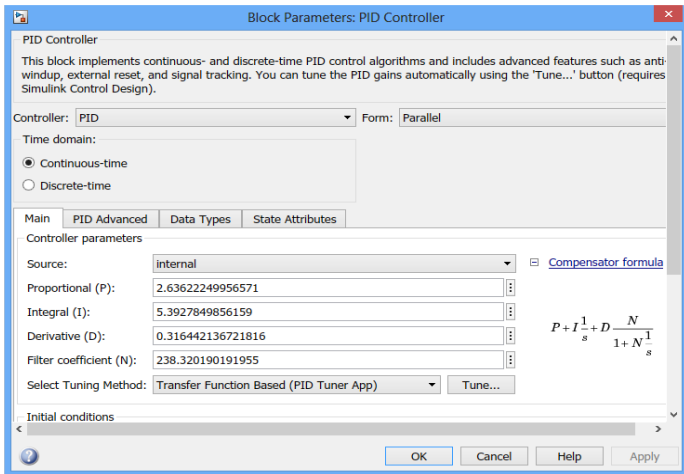

Fig. 4 PID gain coefficients

3. Results and Discussion

The position of the input member of the slider-crank mechanism was asked to attain 90 degrees using the PID control approach. The desired reference position value is given while the settling time is 0.01367 seconds, as can be shown in Fig. 6. The graph shows that 96.94 is the highest value ever attained. A maximum overshoot of 7.71% was obtained, resulting in the reference value that was desired.

Fig. 7 gives a close view of the angle value of the input limb. It is seen in the graph that it is very close to 90 degrees. It takes different values between 89.99 and 89.998 values.

The entry limb's angle value should increase to 90 degrees. The output angle value on the display screen reaches 90 degrees after the PID control is applied, as shown in Fig. 5.

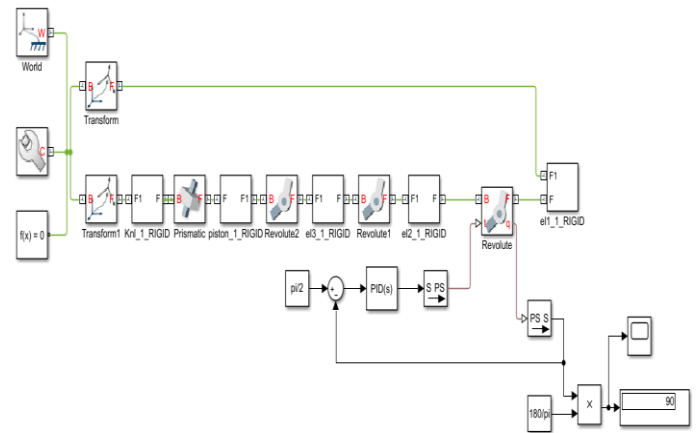

Fig. 5 Block diagram with output angle value

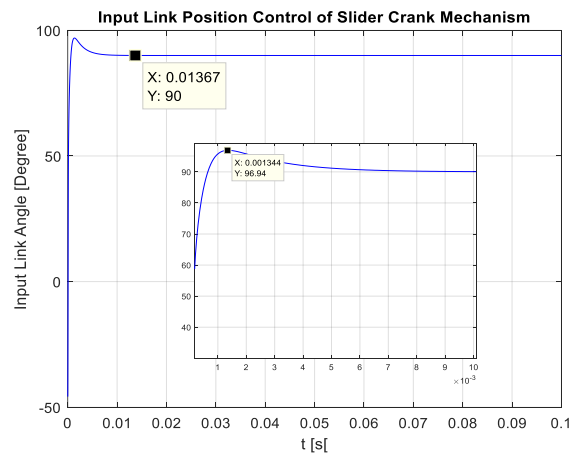

Fig. 6 Input Link Position Control of Slider Crank

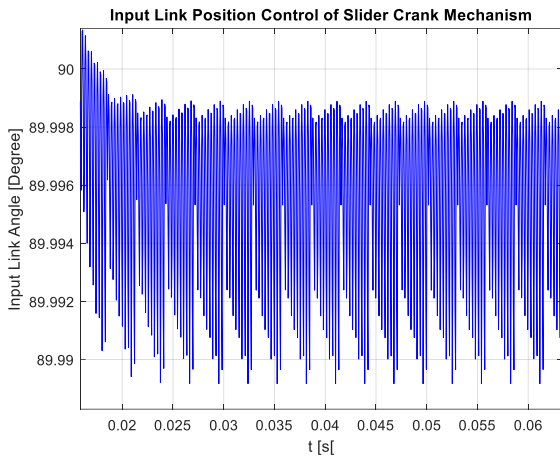
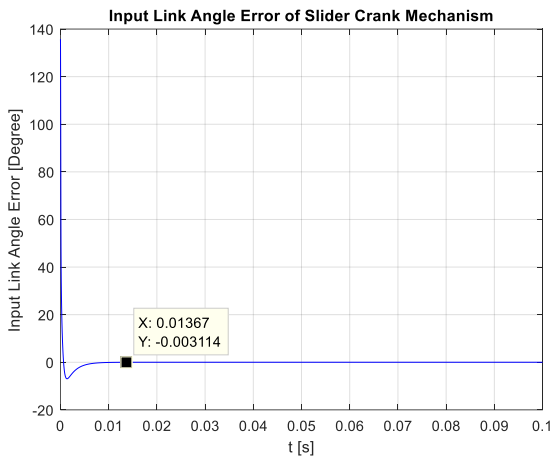

Fig. 7 Close View of Input Link Angle

The input limb's error value is displayed in Fig. 8. At the point of settling, when 90 degrees was attained, the error value was calculated to be 0.003114. It can be observed that this error value is quite modest and within acceptable bounds.



4. Conclusions and Recommendations

In this study, a solid model of the slider-crank mechanism was made, and it was then converted from Solidworks to Matlab/Simmechanics. The mechanism's position was controlled by applying the PID control approach to the blocks created in the Simmechanics environment. It was adequate to execute the position control of the input component using the slider-crank mechanism because it only has one degree of freedom. With a maximum overshoot of 7.71% and an inaccuracy of 0.003114, the movement finished in 0.01367 seconds and met the intended 90 degree reference value.

References

[1] Ahmad, F., Hitam, A. L., Hudha, K., & Jamaluddin, H. (2011). Position tracking of slider crank mechanism using PID controller optimized by Ziegler Nichol's method. *Journal of Mechanical Engineering and Technology (JMET)*, 3(2), 27-41.

[2] Lin, F. J., & Wai, R. J. (2001). Sliding-mode-controlled slider-crank mechanism with fuzzy neural network. *IEEE Transactions on Industrial Electronics*, 48(1), 60-70.

[3] Lin, F. J., Fung, R. F., Lin, H. H., & Hong, C. M. (2001). A supervisory fuzzy neural network controller for slider-crank mechanism. *Mechatronics*, 11(2), 227-250.

Fig 8 Input Link Angle Error

Fig. 9 gives a close view of the error value of the input limb. It is seen in the graph that it is very close to 0 degrees. It takes different values between 0.011 and 0.001 values.

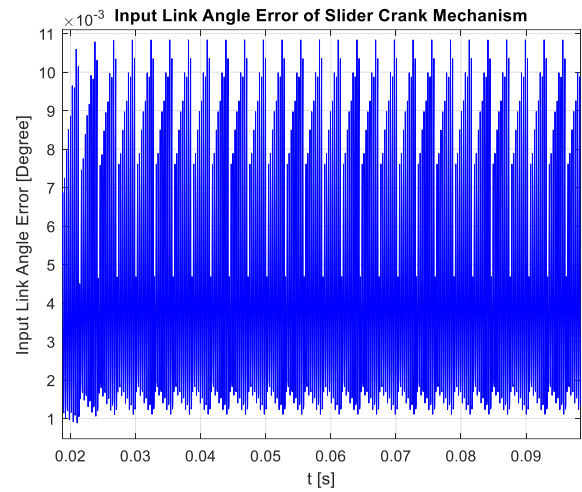

Fig. 9 Close View of Input Link Angel Error

The slider-crank mechanisms that will be created for different reasons can use the application made in this study. These systems' speeds can be controlled using PID control. Simmechanics may be used to translate mechanisms with precise dimensions and specified material properties, and blocks can be used to calculate PID control gain coefficients. Therefore, real-time applications will make use of these gain coefficients.

[4] Lee, C. D., Chuang, C. W., & Kao, C. C. (2004, December). Apply fuzzy PID rule to PDA based control of position control of slider crank mechanisms. In *IEEE Conference on Cybernetics and Intelligent Systems, 2004*. (Vol. 1, pp. 508-513). IEEE.

[5] Faraji, H., & Farzadpour, F. (2013, April). Intelligent position control of slider-crank mechanism in the ship's propeller. In *2013 3rd Joint Conference of AI & Robotics and 5th RoboCup Iran Open International Symposium* (pp. 1-7). IEEE.

[6] Lin, F. J., Lin, Y. S., & Chiu, S. L. (1998). Slider-crank mechanism control using adaptive computed torque technique. *IEE Proceedings-Control Theory and Applications*, 145(3), 364-376.

[7] Kudra, G., Balthazar, J. M., Tusset, A. M., Wasilewski, G., Stańczyk, B., & Awrejcewicz, J. (2022). Dynamics analysis and control of a pendulum driven by a DC motor via a slider-crank mechanism. *Mechanical Systems and Signal Processing*, 166, 108415.

[8] Sarıgeçili, M. İ., Akçalı, İ. D. (2018). Dynamic Modeling of Slider-Crank Mechanism for Selecting Input Parameters for Desired Piston Speeds: Lumped Mass Approach. *Çukurova Üniversitesi Mühendislik-Mimarlık Fakültesi Dergisi*, 33(4), 67-82.

[9] Atakök, G., & Balci, S. (2022). CNC Kumaş Kesim Makinesindeki Krank-Biyel Mekanizmasının Kinematik

- Analizi ve Kesici Bağlantı Uzunluklarının Performansa Etkisi. *Mühendis ve Makina*, 63(706), 41-54.
- [10]Chuang, C. W., Lee, C. D., & Huang, C. L. (2006, May). Applying experienced self-tuning PID control to position control of slider crank mechanisms. In *International Symposium on Power Electronics, Electrical Drives, Automation and Motion, 2006. SPEEDAM 2006*. (pp. 652-657). IEEE.
- [11]Flores-Campos, J. A., Perrusquía, A., Hernández-Gómez, L. H., González, N., & Armenta-Molina, A. (2021). Constant speed control of slider-crank mechanisms: A joint-task space hybrid control approach. *IEEE Access*, 9, 65676-65687.
- [12] Lau, S. C., Othman, W. A. F. W., & Bakar, E. A. (2013, November). Development of slider-crank based pole climbing robot. In *2013 IEEE International Conference on Control System, Computing and Engineering* (pp. 471-476). IEEE.
- [13]Sang, Y., Karayaka, H. B., Yan, Y., & Zhang, J. Z. (2014, September). Resonance control strategy for a slider crank WEC power take-off system. In *2014 Oceans-St. John's* (pp. 1-8). IEEE.
- [14]Saito, H., Ishikawa, J., Kamamichi, N., Shiotsuki, T., & Furuta, K. (2009, August). Self-tuning control for rotational speed of slider-crank mechanism. In *2009 ICCAS-SICE* (pp. 29-33). IEEE.
- [15]Işık, E. (2002). Titreşimli zeytin hasat makinalarında kullanılan mekanizmanın kinematik analizi. *Uludağ Üniversitesi Ziraat Fakültesi Dergisi*, 16(2), 93-100.
- [16]Halıcıoğlu, R., & Dulger, L. C. (2013). Krank pres mekanizması: kinematik analizi ve benzetimi. 16. *Ulusal Makina Teorisi Sempozyumu, Erzurum*, 451-458.
- [17]Perrusquia, A., Flores-Campos, J. A., Torres-Sanmiguel, C. R., & Gonzalez, N. (2020). Task space position control of slider-crank mechanisms using simple tuning techniques without linearization methods. *IEEE Access*, 8, 58435-58442.