

## Redundant Data Center Planning For Universities

Veli ÇAPALI<sup>1\*</sup>, Kadir SÜMER<sup>1</sup>, Mevlüt ERSOY<sup>2</sup>

<sup>1</sup>Suleyman Demirel University, Isparta Health Services Vocational School, Department of Medical Services and Techniques

<sup>2</sup>Suleyman Demirel University, Faculty of Engineering and Nature, Department of Computer Engineering

**Received:** 01/11/2022 **Revised:** 29/05/2023, **Accepted:** 28/11/2024, **Published:** 31/12/2024

### Abstract

During the Covid-19 pandemic period, when remote education and working from home came to the fore, the importance of university information and remote education systems in this process has emerged. The digital transformation process and business continuity in the information technology infrastructure has been of great importance in terms of the services provided to students and staff during the pandemic period. The need for infrastructure for areas such as automation systems, electronic document management systems, online education and learning management systems has suddenly increased during the pandemic process, and it has been a situation faced by universities to meet this need and ensure business continuity by data centers. Because; various applications were made for the criteria to be considered in the design of the data center, redundant infrastructure, security, and later flexibility and business continuity. In this study, Suleyman Demirel University data center planning and business continuity application is given by presenting how the three-location redundant data center planning should be done according to TIER and ISO22301 standards.

**Keywords:** Data Center, Business continuity, Redundancy, TIER, ISO 22301.

## Üniversitelere Yönelik Yedekli Veri Merkezi Planlaması

### Öz

Uzaktan eğitim ve evden çalışmanın öne çıktığı Covid-19 pandemi döneminde, üniversite bilgi ve uzaktan eğitim sistemlerinin bu süreçte önemi ortaya çıkmıştır. Bilişim alt yapısındaki dijital dönüşüm süreci ve iş sürekliliği pandemi döneminde öğrencilere ve personele sunulan hizmetler açısından büyük öneme sahip olmuştur. Otomasyon sistemleri, elektronik belge yönetim sistemleri, çevrimiçi eğitim ve öğrenme yönetim sistemleri gibi alanlar için altyapı ihtiyacının pandemi sürecinde bir anda artması, veri merkezlerini bu ihtiyacı karşılaması ve iş sürekliliğini sağlaması üniversitelerin karşı karşıya kaldığı bir durum olmuştur. Bu nedenle; veri merkezi tasarımında dikkat edilmesi gereken kriterler, yedekli altyapı, güvenlik ile sonrasında esneklik ve iş sürekliliğine yönelik çeşitli uygulamalar yapılmıştır. Bu çalışmada, üç lokasyonlu yedekli veri merkezi planlamasının TIER ve ISO22301 standartlarına göre nasıl yapılması gerektiği sunulurken, Süleyman Demirel Üniversitesi veri merkezleri planlaması ve iş sürekliliği uygulamasına yer verilmiştir.

**Anahtar Kelimeler:** Veri merkezi, İş Sürekliliği, Yedeklilik, TIER, ISO 22301.

\*Corresponding Author: velicapali@sdu.edu.tr

## 1. Introduction

The Covid-19 virus started an epidemic process that emerged in Wuhan, China in the last days of 2019 and spread throughout the world in a very short time. The World Health Organization has accepted this virus as a very dangerous pandemic that has spread throughout the world. The Turkish state has taken many precautions to prevent the spread of the disease in this process. At the beginning of these; A curfew has been declared for those over 65 and under 20, and education and training at all levels has been suspended for a short period of three weeks.

In Turkey, the Ministry of National Education has included students at every school level within the scope of distance education through television channels and the Education Informatics Network (EBA) as of March 23, 2020. In this way, the courses held via EBA have been made available via the internet, TRT channel and television, and TV and internet-based distance education platforms have been actively used (MEB, 2020). In higher education, this process is left to universities. In terms of universities, the application method was generally carried out with software that provides an online environment. In this direction, some universities have provided online simultaneous education using their existing infrastructure. Some have carried out the distance education process through cloud systems with the service procurement method (YÖK, 2020).

In this period; Internet traffic has increased rapidly in universities using the existing infrastructure, and depending on this increase, network equipment such as servers hosting the services offered and routers and switches used to carry this traffic have to work uninterruptedly. In addition to the increase in data center usage scales, another issue that needs to be analyzed in depth is the reliability level and uninterrupted uptime of these data centers. A single outage event with a 90-minute outage can cost an average of more than half a million euros, including recovery costs, loss of end-user productivity and business interruption (Emerson Network, 2021). An ideal data center management policy should plan to reduce power consumption while maintaining a low failure rate. This planning; It can be provided by standards such as TIER and ISO22301, which show the level of competence and competence that the data center can survive and continue to serve in issues such as electricity, cooling, physical security, fire, building durability, network infrastructure, as well as in natural disasters, disasters and similar extraordinary situations. Upon the determination of the standards of data centers, the Uptime Institute and the International Organization for Standardization (ISO) have set forth various certification methods and standards. The Uptime Institute created the TIER certification standard and the ISO 22301 standard.

The purpose of the TIER system is to measure the availability and availability of data centers. There are 4 levels in the TIER certification method and the minimum required technical competencies and infrastructures are specified for each level value (Uptime Institute, 2022). In Tier certification, documents are given for design and operation. While the Tier design certificate is issued for the construction and design of the data center, the Tier operation certificate is a document for the operation of the data center. Upon submission of all the implementation stages and forms of the project to the Uptime Institute, the projects deemed appropriate are given certificates according to their levels. ISO22301 was standard; It is a

management system standard based on the risk approach for the creation, implementation, monitoring, review, continuity and improvement of business continuity (ISO, 2022; Arief et al., 2019.). ISO 22301 is the world's first international standard for the implementation and maintenance of security and flexibility and business continuity management systems requirements, when published in 2012, and effective business continuity plans, systems and processes, and updated in 2019 and implemented as ISO22301:2019 (TSE, 2022).

In this study, data center planning and business continuity practices at Süleyman Demirel University are given by presenting how the three-location redundant data center planning should be done according to ISO22301 and TIER standards.

### **1.1. Data Center**

Data Centers house critical computing resources in controlled environments and under centralized management, enabling businesses to operate around the clock or according to their business needs. These computing resources are server computers; web and application servers, file and print servers, messaging servers, application software and the operating systems that run them, storage subsystems and network infrastructure, etc. systems (Arregoces and Portolani, 2004). The size of a data center can range from a small cabinet to a high-scale data center. The term high scale refers to a flexible and robust computer architecture capable of increasing computing capability across memory, network and storage resources. Regardless of size and name, all data centers perform one thing: to process and transmit information (Kambhampaty, 2022).

Data centers are designed in various sizes, criticality levels and capacities according to the field of activity in which they are used. The basic components of a data center are as follows:

- Sustainably cooled mechanical system
- Electricity distribution, uninterruptible power supplies and generator systems
- Fire extinguishing systems
- Cabin and cabling systems
- Data center infrastructure systems
- Data center monitoring and management systems
- Disaster recovery and business continuity

### **1.2. Business Continuity and Redundancy Standards**

"Redundancy" provides greater reliability, but has a profound impact on initial investments and ongoing operating costs. This situation is more clearly expressed in the diagram below (Figure 1.3). According to the Tier certification standards of the Uptime Institute, data center redundancy and fault tolerances are determined by the following items.

- N: Basic requirement.
- N +1 redundancy: Having an additional unit, module, bus or system to the minimum requirement.
- N+2 redundancy: Two additional units, modules, paths or systems in addition to the minimum requirement.
- 2N redundancy: Two complete units, modules, paths or systems for everything needed for a base system
- 2(N+1) redundancy: Having two full (N+1) units, modules, paths or systems.

Based on the above, the following levels of TIER certifications are made regarding component redundancy for a data center:

- Tier I Data Center: Basic system
- Tier II Data Center: Redundant components
- Tier III Data Center: Simultaneous maintenance possible
- Tier IV Data Center: Fault Tolerant

In these standards, N+1; It covers the design and implementation of all components of a data center as redundant. Well; a backup of the cooling unit, a backup of the uninterruptible power supply, a backup of the generator, a backup of the electrical infrastructure. 2N redundancy; represents the creation of an exact backup of the existing structure at a different point. If it is 2N+1, it includes that all components are eaten for both points (Choorat and Noimanee, 2022).

In terms of uninterrupted business continuity, there is a Disaster Recovery Center (DRC) in a different location (in a different city) in order to achieve 100% uptime and to ensure that the services of N+1, 2N and 2N+1 data centers do not stop in extraordinary situations (flood, earthquake, etc.). is of great importance. Apart from these, certification and implementation are very important for business continuity. At this point, ISO22301 standards come to the fore. According to ISO22301;

- Asset inventory should be created
- Process inventory should be created
- Risk analysis should be created for assets and processes

- Plan and Process improvements
- Development of disaster recovery plan and process
- Preparation of crisis management plans
- Preparation of exercise management plans

These processes need to be established.

From the analyzes made based on the data in the standards mentioned above, the analysis of the impact of the interruption and/or disaster on the institution, the level of impact and probability are revealed. The final results of the risk assessment describe the sequence of relevant business processes. Taking measures according to these risks ensures that business continuity is kept at the highest level.

## **2. Redundant Data Center Planning**

### **2.1. Planning Phase**

When planning a data center, only the number of servers to be hosted in the data center should not be considered. First of all, general capacity planning should be done. In this context, the services to be hosted should be revealed and a growth plan of at least 10 years should be established. Accordingly, network devices, access and ease of cabling infrastructure, security and accessibility features, amount of heat and cooling system to be released depending on the devices to be housed, and general electrical load of all systems should be calculated (Yüzgeç and Günel, 2015).

While planning the physical server; All of the online systems and automation software offered by the institution should be examined separately as both database and application servers, and disk, ram and processor capacities should be considered depending on their growth capacities. Accordingly, appropriate virtualization infrastructure should be created for the services to be hosted. Table 1 lists the general services and servers used for one of our institutions. By examining this list, the number of physical servers, the number of virtualization servers and storage systems were determined. According to this; Virtualization infrastructure was created with 10 physical servers. For systems that are not included in virtualization, 10 physical servers were planned.

**Table 1.** Systems to be hosted and resources planned.

Virtual Servers	Ram and CPU Specification	Piece
Data Bases	128Gb Ram, 12 Core Processor	10
Web Servers	12Gb Ram, 4 Core Processor	15
Application Servers	128Gb Ram, 12 Core Processor	10
Otomation Servers	24Gb Ram, 8 Core Processor	10
Service Servers	8Gb Ram, 4 Core Processor	15
E-Mail Services	128Gb Ram, 16 Core Processor	4
Log Store Servers	64Gb Ram, 12 Core Processor	4
Other Servers	24Gb Ram, 4 Core Processor	20
Digital Surveillance (Camera) Recording Servers	32GB Ram 12 Core Processor	4
PACs Systems	64Gb Ram, 12 Core Processor	2

In the light of the data in Table 1, the energy loads of the physical servers were calculated. Data center energy use per server includes energy used by the servers themselves. However, the energy usage calculation of the data center includes the energy used by the servers as well as networking, storage, uninterruptible power supplies for energy redundancy, cooling system, lightings and auxiliary devices. In this context, the heat loads produced by the servers and network devices have been calculated according to their absorbed energy. In this context, a maximum load of 30 kW has been revealed. This load case is the base requirement value expressed as “N”. In order to create a Tier 3 level structure, N+1 level transactions are required. For N+1 redundancy, planning has been made in such a way that at least two uninterruptible power supplies will meet 30kW and two air conditioners with redundancy to meet this temperature. Redundant electrical infrastructure and electrical panel system should be built for this power requirement. Two proposed methods are used for this. The first is parallel connected structures and the second is in the form of two different source feeds in the form of A + B. In this study, A+B double source feeding is planned.

Storage planning varies according to the type of data to be stored. A data storage unit consisting entirely of flash and/or SSD disks should be preferred because the data belonging to application and database servers are processed quickly and are instantly changing data. For less data to be read and written, disk units with SAS and NL-SAS disk structures should be used. Considering today's data compression and deduplication technology, compression and deduplication features should be sought in data storage units. The data in the institution should be analyzed according to their types and the data storage unit should be planned.

**Table 2.** Selection of appropriate storage size and storage disk type for planned systems.

Virtual Servers	Data Classification	Storage Capacity	Disk Type
Data Bases	Instantly changing, fast, compressed, and singularized data	Total allocated space for all databases 50 TB	SSD / Flash
Web Servers	Instantly changing, fast, compressed, and singularized data	Total allocated space for all web servers 2 TB	SSD / Flash
Application Servers	Instantly changing, fast, compressed, and singularized data	Total allocated space for all application servers 10 TB	SSD / Flash
Automation Servers	Instantly changing, fast, compressed, and singularized data	Total allocated space for all automation servers 5 TB	SSD / Flash
Service Servers	Instantly changing, fast, compressed, and singularized data	Total allocated space for all service servers 1 TB	SSD / Flash
E-Mail Services	Instantly changing, fast, compressed, and singularized data	Total allocated space for all email services 40 TB	SSD / Flash
Log Store Servers	Instantly changing, slow, compressed and deduplicated data	Total allocated space for all log data 20TB	SAS / NLSAS
Other Servers	Instantly changing, fast, compressed, and singularized data	Total allocated space for all other servers 10TB	SSD / Flash
Digital Surveillance (Camera) Recording Servers	Instantly changing, slow, uncompressed, and non-deduplicated video and picture data	Total allocated space for all recordings 250TB	NLSAS
PACs Systems	Instantly changing, slow, uncompressed, and non-deduplicated video and picture data	Total allocated space for all PACs data 100TB	NLSAS

As seen in Table 2, SSD and Flash disks and SAS and NL-SAS disks should be divided into two separate data storage units and used in a separate structure (This structure may change depending on the support of the storage units). The basic requirement, referred to as “N” in this case, is two separate Flash and SAS/NLSAS disk units. In order to create a Tier 3 level structure, N+1 level transactions are required. For N+1 redundancy, one more disk unit should be planned.

It is very important to plan the network infrastructure in order for the server and data storage systems to transfer data to the users in a redundant and fast manner and to receive the data from the user. While making this planning, the number of users and clients should be considered. In addition, the device and network connection types used by the clients should be calculated. Although the number of staff and students varies for universities; Students generally use wireless connection with mobile devices, staff use both wired and wireless connections. Due to serving approximately 50,000 users; At least 10 Gbps network switching between servers, at least 40Gbps between backbones and edge welcome switches, and at least 10Gbps between edge welcome-side switches are planned. In addition to this planning, there should be another backup service other than ULAKNET infrastructure, which is the internet service provider of universities. This service provider should have separate and independent fiber optic lines from the existing infrastructure provider and should be activated without loss of time in case of an interruption in the existing lines.

All of the data in the data storage systems in active use are expressed as hot data and these data can change instantly. Such systems need to be backed up periodically. These hot data should be subject to backup planning according to the type and importance of the services provided.

**Table 3.** Selection of the appropriate backup plan for the planned systems.

Virtual Servers	Data Classification	Backup Plan
-----------------	---------------------	-------------

<b>Data Bases</b>	Instantly changing, fast, compressed, and singularized data	Every week full, daily incremental
<b>Web Servers</b>	Instantly changing, fast, compressed, and singularized data	Every week full, daily incremental
<b>Application Servers</b>	Instantly changing, fast, compressed, and singularized data	Every week full, daily incremental
<b>Automation Servers</b>	Instantly changing, fast, compressed, and singularized data	Every week full, daily incremental
<b>Service Servers</b>	Instantly changing, fast, compressed, and singularized data	Every week full, daily incremental
<b>E-Mail Services</b>	Instantly changing, fast, compressed, and singularized data	Every week full, daily incremental
<b>Log Store Servers</b>	Instantly changing, fast, compressed, and singularized data	Every week full, daily incremental
<b>Other Servers</b>	Instantly changing, slow, uncompressed, and non-deduplicated video and picture data	Every week full, daily incremental
<b>Digital Surveillance (Camera) Recording Servers</b>	Instantly changing, slow, uncompressed, and non-deduplicated video and picture data	Every week full, daily incremental

With the backup planning in Table 3, it is planned to keep the cold data in a separate storage unit by performing compression and deduplication. In this case, the basic requirement expressed as “N” is the backup unit where the cold data is kept. N+1 level is required to create a Tier 3 level structure, 2N+1 level is required for Tier 4 level to be formed. Backup units should be planned for N+1 and/or 2N+1 redundancy.

An indispensable part of data centers is instantaneous monitoring and security. At this point; All equipment of the data center, usage conditions, performances, temperature, electricity, etc. of the personnel responsible for the operation of the data center. must have a full view and management of the data. In this respect, a data center infrastructure management system (Data Center for Infrastructure Management – DCIM) should be established for data centers. Data center security is provided by adding cabinet lock mechanisms, door lock mechanisms and cameras to these systems. For fire safety, FM200 and/or Novec gas extinguishing systems should be applied. Such systems protect and extinguish all basic fire classes, are also safe, clean and insulating. For this reason, it is planned to use FM200 in data centers.

For universities with Research and Application Hospitals, the planning situation should be structured as 2N or 2N+1 instead of N+1. At this point, the data center structure is planned to be 2N+1. In addition, it is planned to establish a disaster recovery center in a different location (city). In the case of 2N+1, all N+1 plans mentioned above are planned to be configured in pairs to be 2N+1.

TIER standards were prioritized during the commissioning phase of this structure, the planning of which has been completed. Required availability times for systems valid for TIER Standards/levels are listed below.

- Tier 1 – Basic capacity, single supply for cooling and power supplies, no redundancy elements are expected. The estimated annual working time is stated as approximately 99.671%.
- Tier 2 – Redundant system provides for one-way supply for cooling, power supplies, and redundant and redundant components. The estimated annual working time is stated as approximately 99.741%.
- Tier 3 – Simultaneously serviceable system, Predicts Multiple cooling, power and redundancy systems. The estimated annual working time is stated as approximately 99.982%.



- Tier 4 – Physically isolated redundant systems include redundant and fault-tolerant data centers for each component. The estimated annual working time is stated as approximately 99.995%.

### 2.1.1. Tier 1

In order to meet this standard, it is considered sufficient to have electrical systems and cooling systems in the data center. It is not expected that the systems in the data center will have any redundancy. In other words, we can say that there are N devices in a single line. Figure 1 illustrates this situation on a drawing. It has been studied for a system with 3 cabinets in the drawing. The explanations on Tier2, Tier3, Tier4 will be continued by superimposing this drawing. The estimated annual working time is stated as approximately 99.671%.

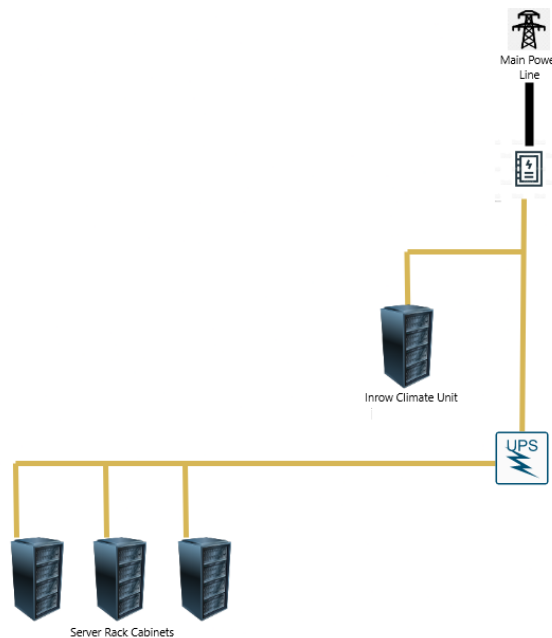
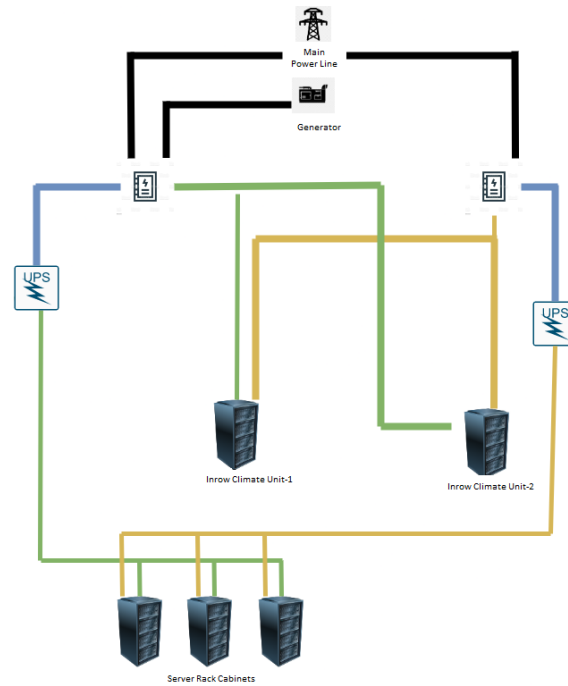

Figure 1. Tier 1 Server Room Requirement Diagram

### 2.1.2. Tier 2

In order to ensure this standard, redundancy (N+1) of devices with important tasks such as electrical systems and cooling systems in the data center is essential. These units include generator, UPS, cooling systems, etc. can be included. As shown in Figure 2, the incoming power line is supported by a generator and uninterruptible power supplies are backed up. At the same time, redundancy of cooling units is provided. The most important detail in this regard is that each unit is fed from 2 different sources. The estimated annual working time is stated as approximately 99.741%.



**Figure 2.** Tier 2 Server Room Requirement Diagram

**2.1.3. Tier 3**

In order to ensure this standard, it has come to the fore that it can be maintained simultaneously (it will not cause a functional interruption during the necessary maintenance or replacement), as well as the redundancy at the points that have undertaken important tasks such as electrical systems and cooling systems in the data center. In Figure 3, this situation is explained for a single data center with an example drawing. The estimated annual working time is stated as approximately 99.982%.

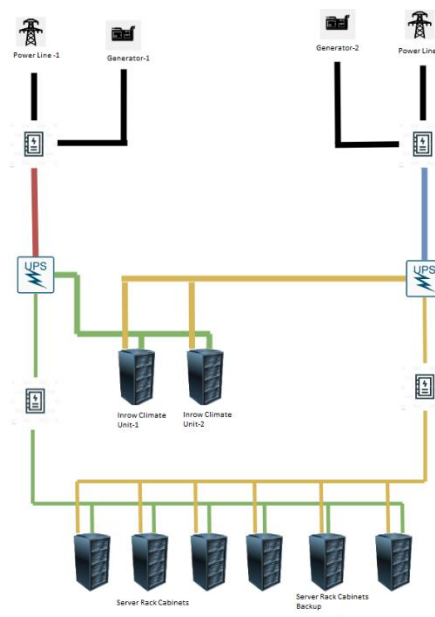

**Figure 3.** Tier 3 Server Room Requirement Diagram

#### 2.1.4. Tier 4

In order to ensure this standard, in addition to the redundancy at the points that have undertaken important tasks such as electrical systems and cooling systems in the data center, in case of a data center-wide error, the systems do not stop even outside the control of the person (in case of a complete failure at this level while awaited controlled maintenance in Tier 3) is expected. According to Tier standards, we can express this situation as  $2N+1$ . In Figure 4, this situation is simply explained for a system room. The estimated annual working time is stated as approximately 99.995%.

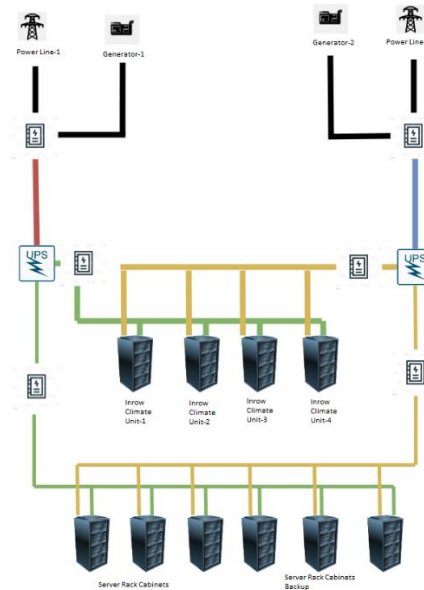

Figure 4. Tier 4 Server Room Requirement Diagram

## 2.2. Implementation

As stated when planning the data centers of our university, Tier and ISO 22301 standards have been taken into consideration. In order to create a Tier4  $2N+1$  structure, 2 separate areas were selected within the campus and it was planned to provide a  $2N$  structure first. In addition to this plan,  $N+1$  structuring was also applied for each point and a  $2N+1$  arrangement was made. Within the scope of this Plan, two separate data centers in the East and West campuses of Süleyman Demirel University were established with  $N+1$  redundancy. 96 core single mode fiber cables were applied between data centers. The third location, the FKM application in a different city, was completed and the structure shown in Figure 5 was created.

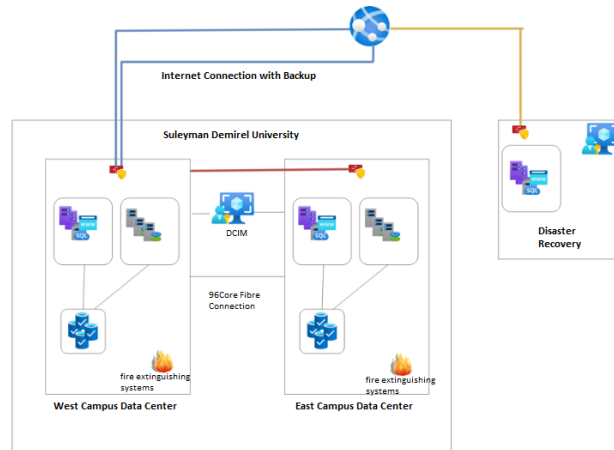

Figure 5. S.D.U. Data Centers

### 2.2.1. West Campus Data Center

The western data center is considered as two parts, the electrical room and the network-system room, during the architectural planning phase. The high-risk electrical room is isolated from the data center while creating the architectural plan. Cold corridor structure is preferred for the data center. In this structure, instead of raising the base, cabling etc. For the passage of the elements, galvanized panning and cabling are made on the cabinet. The data center layout and drawing are presented in Figure 3.2.1. Copper and fiber cabling is placed as two separate passive cabins, which are kept out of the cold aisle using the mirroring method. Network and cabling operations are separated by creating a NOC (Network Operations Center) structure. Thus, passing into the cold corridor where the systems are located for network works was prevented and both system security was ensured and energy efficiency was achieved by protecting the corridor air circulation. By using card reader lock mechanisms on each of the network cabinets in the NOC environment, the persons who will have access to the network cabinets are separated and authorization definitions are made. The entrance to the corridor, where the systems are located, is also isolated with an automatic door with a card reader, allowing authorized persons to access the card reader here. In addition to these, other processes carried out both in the data center and in the electrical room are explained below.

**Table 4. Sensor distribution used in data centers and electrical room**

Sensor Type	Location	Piece	Data Center
Wired humidity-temperature sensor	Each cabin was used both at the front and at the back.	26	East/West Data Center and Electrical Room
Wireless temperature sensor	It was used in the room for ambient temperature.	3	East/West Data Center
Liquid Sensor	Used on room floors for liquid contact.	4	East/West Data Center and Electrical Room
Motion sensor	For monitoring the movements in the room and for the cold corridor lighting system.	2	East/West Data Center
IP Cameras	It has been used for monitoring data centers.	8	East/West Data Center and Electrical Room
Door Sensor	Both front and rear doors of each cabin were used in the room entrance doors.	28	East/West Data Center and Electrical Room
Pressure and Airflow Sensor	It is used to measure the air flow and pressure in the cold aisle.	1	West Data Center
Earthquake sensor	For automatic opening of doors and lock systems in case of an earthquake.	2	East/West Data Center
Smoke and Flame Sensors	It is used for fire detection.	11	East/West Data Center and Electrical Room
Vibration Sensor	It is used to detect the situations that may occur due to the vibrations of the air conditioning system.	1	East Data Center
Electrical-Monitoring Analyzers	Each feed is used to monitor the inlet and outlet lines.	8	East Data Center and Electrical Room

Special fire-resistant paints with TS EN 13381-8:2013 certificate were used on the walls of both rooms, and doors with EL120 certificate and 120 minutes fire resistance in accordance with TSE - CE - EN standards were used at the entrances of both rooms.

- FE180 fire resistant cable in accordance with IEC 60331-21/23/25 standards is used in all of the ceiling-top open area wiring of both rooms.

- Lighting, power, sensor, etc. in both rooms. All of the wiring (fire resistant cables) is taken under protection by passing through galvanized pipes.

- Lighting and switching systems; Surface mounted, fire and explosion resistant (exproof) material is preferred in accordance with IP65 standards.

- FM200 fire extinguishing system is integrated with fire detection automation within the data center management. With this integration, air conditioning systems are turned off during a fire and FM200 gas filling is provided by opening the covering ceilings of the cold corridor. In addition to the sensors of the FM200 system, the fire conditions can also be monitored with the sensors on the DCIM system and communication is provided with the FM200 fire control panel. FM200 and DCIM applications were made in the electrical room.

- With 94 sensors on the DCIM system, both east and west data centers and the electrical room are monitored comprehensively from a single point. The sensors used and their places of use are given in Table 4.

With the rules created on the DCIM system, each change in the data centers is communicated to the relevant personnel. This system not only provides monitoring but also automation management. Air conditioning systems are managed through the DCIM system.

Intelligent precision air conditioning systems are used in N+1 construction. Ambient cooling is done by using the data obtained from the temperature and humidity sensors located on the front and rear doors of each cabin. In the same way, N+1 air conditioning was applied in the electrical room. Cooling systems are fed by uninterruptible power supplies separate from server systems.

A front reception room was created before the data center entrance. In this room, the person who will enter the data center is purified and prepared and taken inside. At the same time, both the earthquake sensor and the control panel and tube of the FM200 fire extinguishing system are in this room.

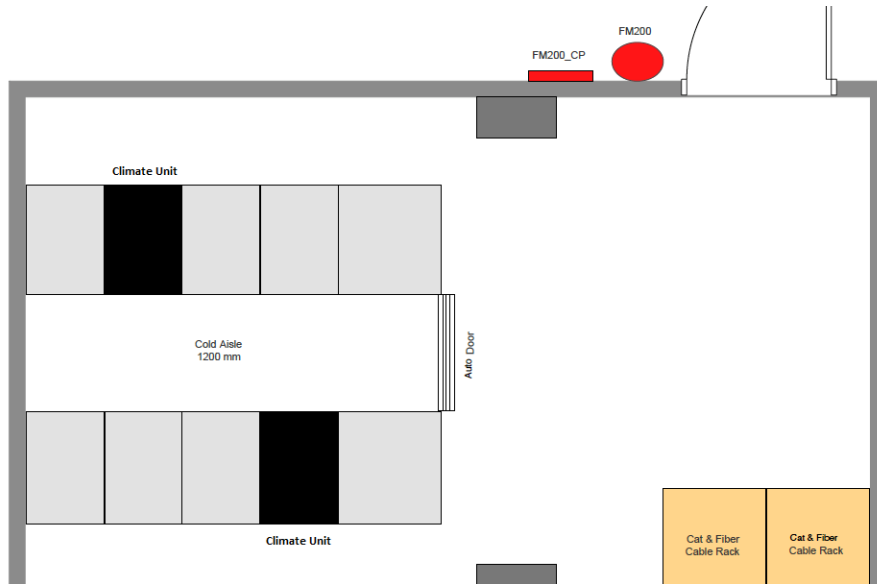

Figure 6. West Campus Data Center Layout Plan



Figure 7. West Campus Data Center

The western data center power distribution is shown schematically in Figure 8. Electricity distribution room planning has been made in order to ensure energy uninterruptedness in the data center. Apart from the generator feeding the building, the positioning of the generator feeding the data center and the two uninterruptible power supplies in the A+B configuration

feeding the system cabinets and a redundant energy line are provided to the double power sourced devices in the cabins. Air conditioning systems are also fed by separate uninterruptible power supplies. There are separate lines from two places to the common busbar of the distribution panel in the electrical room. One of these lines is the line coming from the transformer main panel (the line with the campus common generator), and the other is the line coming from the generator panel of the building. Since these two lines feed the same busbar, they will be controlled by a transfer switch. The priority is the line coming out of the main distribution panel, it is planned to feed the system from the generator of the building in case of a problem on this line. A line taken from this common busbar enters 4 uninterruptible power supplies. The lines coming out of the uninterruptible power supplies are connected to another distribution busbar in the A and B distribution boards. The lines taken from these A and B busbars feed the air conditioners, system and network cabinets. In addition, the lines coming from the A and B busbars are combined with the 40A automatic transfer switch, feeding the card access system, DCIM system, fire detection and extinguishing systems, data center lighting systems.

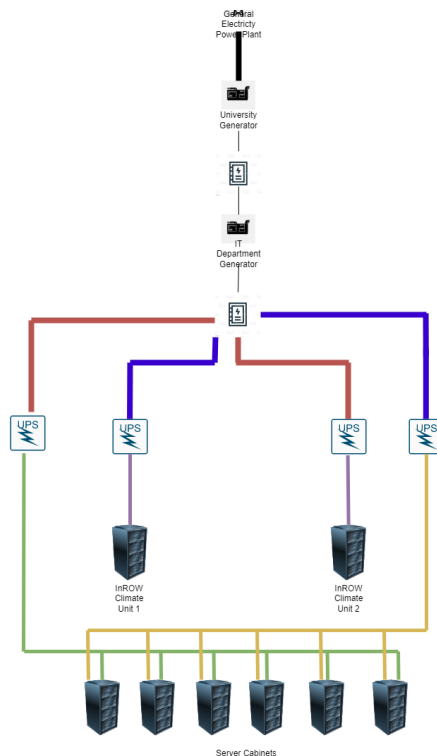

**Figure 8.** West Campus Data Center Energy Distribution

### 2.2.2. East Campus Data Center

The eastern data center was planned as a single-storey, single-architectural structure independent of the existing buildings on the campus during the architectural planning phase. For the eastern data center, underfloor cooling structure was preferred. In this structure, a 50 cm high floor was raised and cabling etc. Underfloor galvanized panning and cabling were applied for the passage of the elements. The data center layout and drawing are presented in Figure 9.

Copper and fiber cabling is placed as a passive separate network cabinet using the mirroring method. In addition to these, other processes performed in the data center are explained below.

Fire and moisture resistant special plasterboard in accordance with TS EN 520-A1 standards was used on the walls of the room, and doors with EL120 certificate and 120 minutes fire resistance in accordance with TSE - CE - EN standards were used at the entrance of the room.

In all of the cabling used in the room, FE180 fire resistant cable is used in accordance with IEC 60331-21/23/25 standards.

Lighting, power, sensor etc. inside the room. All of the wiring (fire resistant cables) is taken under protection by passing through galvanized pipes.

Lighting and switching systems; Surface mounted, fire and explosion resistant (exproof) material is preferred in accordance with IP65 standards.

The FM200 fire extinguishing system is integrated with the fire detection automation within the data center management. With this integration, air conditioning systems are turned off during a fire and FM200 gas is filled inside. In addition to the sensors of the FM200 system, the fire conditions can also be monitored with the sensors on the DCIM system and communication is provided with the FM200 fire control panel.

The eastern data center is also located on the common DCIM system.

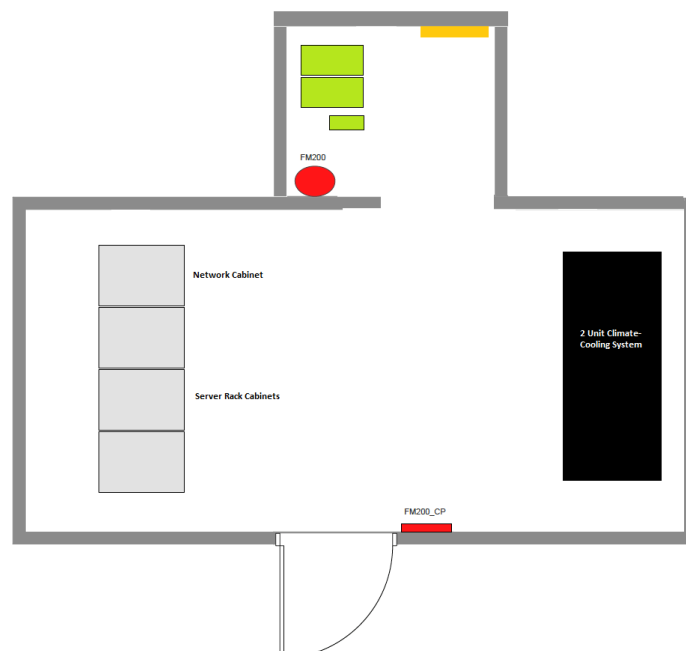
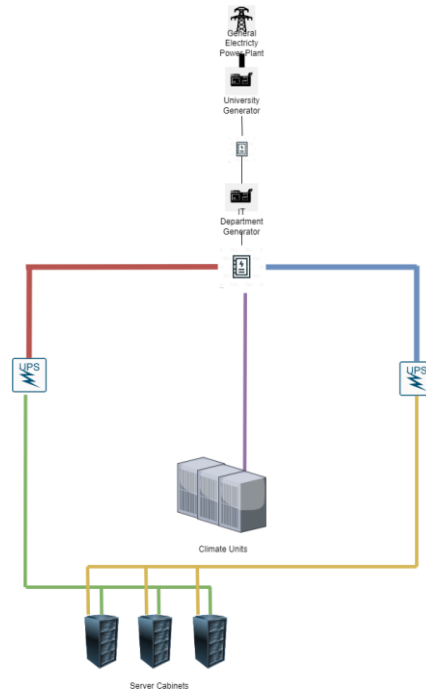

Figure 9. East Campus Data Center Layout Plan





**Figure 10.** East Campus Data Center energy distribution

The eastern data center energy distribution is shown schematically in Figure 10. Electricity distribution planning was made in order to ensure energy uninterruptedness in the data center. Apart from the generator feeding the building, the positioning of the generator feeding the data center and the two uninterruptible power supplies in the A+B configuration feeding the system cabinets and a redundant energy line are provided to the double power sourced devices in the cabins. Air conditioning systems are fed depending on the generator line. Separate lines are coming from two places to the common busbar of the electricity distribution panel. One of these lines is the line coming from the transformer main panel (the line with the campus common generator), and the other is the line coming from the generator panel of the building. Since these two lines feed the same busbar, they will be controlled by a transfer switch. The priority is the line coming out of the main distribution panel, it is planned to feed the system from the generator of the building in case of a problem on this line. The lines taken from this common busbar enter 2 uninterruptible power supplies. The lines coming out of the uninterruptible power supplies are connected to another distribution busbar in the A and B distribution boards. The lines taken from these A and B busbars feed the system and network cabinets. In addition to A and B uninterruptible power supplies, a third redundant uninterruptible power supply is in the cabinet by using an automatic transfer switch; DCIM system feeds fire detection and extinguishing systems, data center lighting systems.

### 2.2.3. Disaster Recovery Center

Disaster recovery center (FKM) plays a vital role in restoring the organization's data and providing emergency services from this data center in the event of emergency and dangerous accidents, disasters and large-scale disasters. FKM installation is mandatory for large-scale data centers in public institutions and organizations. Since FKMs come to the fore in large-scale disasters and disasters, they should be installed in a different location than existing data centers,

or even in a different city. Within the scope of the study, Süleyman Demirel University FKM is kept in a data center with Tier 3 certificate in a different city. While our data centers located in the eastern and western campuses of our university work with instant data transfer in an active-passive structure, data is sent from the center to FKM via the tunnel network structure (side to side vpn). A "multi-purpose" backup structure is used, which allows the data in the eastern and western data centers to be restored to multiple sites with multiple methods, with the aim of recovering nearly 90% of the data. All data centers belonging to our university; It is within the scope of large-scale data systems, and transfers are made between data centers with software with special algorithms so that all data can be recovered and restored without a long downtime and complex recovery processes. For an emergency, the FKM scenario is practiced within the scope of ISO quality processes.

### 3. Results and Discussion

In this study, information about the digital transformation process and business continuity in the informatics infrastructure, which has become prominent in the world and in our country in recent years with the Covid-19 pandemic, the issues to be considered in the planning of data centers, the criteria and certificates related to this subject, will be presented at the end of the study. In this section, the example of Süleyman Demirel University redundant data center design and implementation is presented in general terms. The business continuity situation mentioned in the planning phase of the data centers has been tested with the scenarios for the transfer of data between the data centers and the creation of active-passive redundancy, failure and maintenance situations and the operation of the backup systems, and as a result, the adequacy of the redundant infrastructure necessary to ensure business continuity has been placed. With the advantages of having redundant data centers and FKM in different cities,

- Data centers are not affected by their long-term maintenance that concerns the entire university,
- Isolating data centers from failures caused by other buildings due to the location of data centers in different campuses within the university and separately and independently from existing campus buildings,
- Minimizing the uninterruptedness and downtime by feeding the system by the other uninterruptible power supply in case of a failure in any of them due to the A+B redundancy of the uninterruptible power supplies and electrical infrastructure,
- Earthquake, flood etc. Ensuring business continuity and not losing contact with the outside world, as FKM is located in a different city as an emergency action plan in major disasters,
- Providing instant (25 sec) active-passive mirroring and daily cold data backup, apart from backup only as daily cold data, and returning from backup in case of emergency, business continuity by getting up and running passive systems in the backup data center within minutes, provided.

## **Ethics in Publishing**

There are no ethical issues regarding the publication of this study.

## **Author Contributions**

Authors declare no contributions.

## **References**

- [1] Arief, R., & Putra, Y. H. (2020, January). Design Business Continuity Plan of Data Center Using ISO 22301: 2012. In International Conference on Business, Economic, Social Science, and Humanities–Economics, Business and Management Track (ICOBEST-EBM 2019) (pp. 45-47). Atlantis Press.
- [2] Arregoces, M., & Portolani, M. (2003). Data center fundamentals. Chapter 1:Overview of Data Centers(pp. 5-7). Cisco Press.
- [3] Choorat, P., & Noimanee, S. (2022, March). Design of Cooling System of Tier 3 Standard for Rack Enclosure in the Containerized Data Centers. In 2022 International Electrical Engineering Congress (iEECON) (pp. 1-5). IEEE.
- [4] Power, E. N. (2011). Understanding the cost of data center downtime: an analysis of the financial impact on infrastructure vulnerability. white paper.
- [5] Hwaiyu Geng, P. (2015). Chapter 2: Data Centers—Strategic Planning, Design, Construction, and Operations (pp. 3-14). Data Center Handbook.
- [6] <https://www.iso.org/standard/75106.html>, Eriřim Tarihi: 17.03.2022
- [7] Kambhampaty S., (2022). Infrastructure Architecture Essentials for Data Center and Cloud. Chapter 1:Data Center(3-6). Independently published.
- [8] <https://www.meb.gov.tr/bakan-selcuk-koronaviruse-karsi-egitimalaninda-alinan-tedbirleri-acikladi/haber/20497/tr>, Eriřim Tarihi: 18.03.2022
- [9] <https://www.tse.org.tr/IcerikDetay?ID=2044&ParentID=1064>, Eriřim Tarihi: 19.03.2022
- [10] <https://uptimeinstitute.com/tiers>, Eriřim Tarihi: 17.03.2022
- [11]<https://www.yok.gov.tr/Sayfalar/Haberler/2020/universitelerde-uygulanacak-uzaktan-egitime-iliskin-aciklama.aspx>, Eriřim Tarihi: 18.03.2022
- [12] Yüzgeç, U., & Günel, A. (2015). Üniversitelere Yönelik Bir Veri Merkezinin Enerji Planlaması. Bilecik Şeyh Edebali Üniversitesi Fen Bilimleri Dergisi, 2(2), 17-24.