

THE BEHAVIOR OF CONCRETE SMALL FLAT PLATE REINFORCED WITH DIFFERENT RATIOS OF STEEL FIBER

Raghad Ali AL-SAADİ¹, Tuncer CELİK²
¹Civil Engineering, Altınbaş University, Istanbul, Turkey
raghadali7878@gmail.com
([id](https://orcid.org/0000-0002-5116-799X) <https://orcid.org/0000-0002-5116-799X>)
²Civil Engineering, Altınbaş University, Istanbul, Turkey
tuncer.celik@altinbas.edu.tr,
([id](https://orcid.org/0000-0002-3011-299X) <https://orcid.org/0000-0002-3011-299X>)

Received: 04.11.2022

Accepted: 08.03.2024

Published: 31.12.2024

*Corresponding author

Research Article

pp.249-263

DOI: 10.53600/ajesa.1199412

Abstract

Due to the experimental nature of the investigation, it is not possible to quantify the punching shear transfer mechanisms. In addition, these calculations do not account for the impact of fiber length, fiber shape, or fiber length-to-diameter ratio on the punching shear resistance of slabs. These factors have a major effect on the binding strength of steel fibers in concrete, which has an effect on the strength of the concrete, which affects the punching shear capacity of SFRC slabs. In the case of thin slabs with a large span-to-thickness ratio, flexural deformation dominates the slab's behavior. In this study, the modal features of small-scaled concrete slab models were explored using the commercial program ANSYS 16 and compared to earlier studies. The ANSYS results revealed that the geometry model used to perform a mode shape animation is animatable. This study examines the deformation differences between two types of SFRC and the influence of these changes on slabs. The final finding was that the addition of steel fibers considerably improves the punching and shear resistance of the slabs. Utilizing steel fibers with a fiber volume between 30 and 60 kg/m³ increases the punching shear resistance of the slabs in direct proportion to the fiber volume.

Keywords: Small Plate Slabs, Crimped Steel Fibres, Hooked End Steel Fibres

FARKLI ÇELİK ELYAF ORANLARI İLE GÜÇLENDİRİLMİŞ BETON KÜÇÜK DÜZ LEVHA DAVRANIŞI

Özet

Araştırmamızın deneysel doğası gereği, zımbalama kayması transfer mekanizmalarını ölçmek mümkün değildir. Ek olarak, bu hesaplamalar, lif uzunluğunun, lif şeklinin veya lif uzunluk-çap oranının levhaların delme kesme direnci üzerindeki etkisini hesaba katmaz. Bu faktörlerin, SFRC levhaların delme kesme kapasitesini etkileyen betonun mukavemeti üzerinde etkisi olan betondaki çelik liflerin bağlanma mukavemeti üzerinde büyük bir etkisi vardır. Geniş açıklık-kalınlık oranına sahip ince levhalar durumunda, eğilme deformasyonu levhanın davranışına hakimdir. Bu çalışmada, küçük ölçekli betonarme döşeme modellerinin modal özellikleri, ticari program ANSYS 16 kullanılarak araştırılmış ve önceki çalışmalarla karşılaştırılmıştır. ANSYS sonuçları, mod şekli animasyonunu gerçekleştirmek için kullanılan geometri modelinin canlandırılabilir olduğunu ortaya koydu. Bu çalışma, iki tip SFRC arasındaki deformasyon farklılıklarını ve bu değişikliklerin döşemeler üzerindeki etkisini incelemektedir. Nihai bulgu, çelik liflerin eklenmesinin, levhaların delme ve kesme direncini önemli ölçüde iyileştirdiğiydi. Lif hacmi 30 ile 60 kg/m³ arasında olan çelik liflerin kullanılması, döşemelerin delme kesme direncini lif hacmiyle doğru orantılı olarak artırır.

Anahtar kelimeler: Küçük Plaka Levhalar, Kıvrımlı Çelik Elyaf, Kancalı Uçlu Çelik Elyaf

1. Introduction

Flat concrete plate of small size considered a slab hold by column without beams. This type of plate represents drop panels, and capital, are highly involved in building that had critical space, and such thing is required in car parking and tunnels. This type of structure is often governed by two-way shear failure and often occurs suddenly and catastrophically, therefore this type of failure should be carefully investigated and avoided. Shear pressures are

generally resisted by concrete in terms of concrete strength, as well as traditional flexural and shear reinforcing with varying levels of activity. Using fibers is one of the most active techniques to increase slab strength behavior (Kearns and McConnell 1989). For a very long time, various fibers have been included into concrete to improve its mechanical qualities, especially its resistance to the spread of cracks. Because shear stresses are concentrated at the column-slab connection, concrete flat plates may collapse suddenly under loads much below their flexural strength, making this a major challenge in their design. When the flexural strength of a slab is determined to be adequate but the punching shear strength is not, and when increasing the depth of the slab or using greater concrete strength throughout the slab is not necessary, shearhead reinforcement is used to boost the punching shear strength. A shearhead is an independently specified device embedded in the concrete at the junction that reduces the effect of vertical forces by distributing the load from the floor across a larger area of the column. tested three 150mm slabs with a 19mm steel plate placed over the column and flush with the slab's compression surface to increase the column's effective size (Ilshat, Georgy, and Midkhat 2020). In 1970, three thin slabs of concrete were assessed. Two had shearheads, and one had a duct (7.5mm) at the end of the shearhead arm (Zinn et al. 2014). examined 2005 samples from five different locations. Crucial components are the width of the shearhead and the flat steel strip welded to the steel channel shape (Petkevicius and Valivonis 2010). included an investigation into the open wide collar shear strengthening technique and a numerical study of a flat plate construction with a specific embedded shearhead using the finite element method. She theoretically analyzed the outcomes of using three distinct types of steel plate for shear reinforcement (square steel plate with shear connectors distributed on the surface of the steel plate, cross shape with distributed shear connectors and a square plate which has rounded edge with distributed shear connectors). Due to the brittleness of concrete, punching failure is one of the most severe and catastrophic failures in building construction. a two-way shear failure in a flat plate placed next to a column or at a certain distance from the column face that causes the whole collapse of a structure. A concentrated load or column support zone is where punching shear failure, a brittle local event, often occurs. This kind of failure is catastrophic since there are no preceding, outward, visible indicators of failure. A column is often punched through some of the adjacent slab in a flat slab punching shear failure. An example of a punching shear failure is shown in Figure 1 (Samsudin et al. 2018).

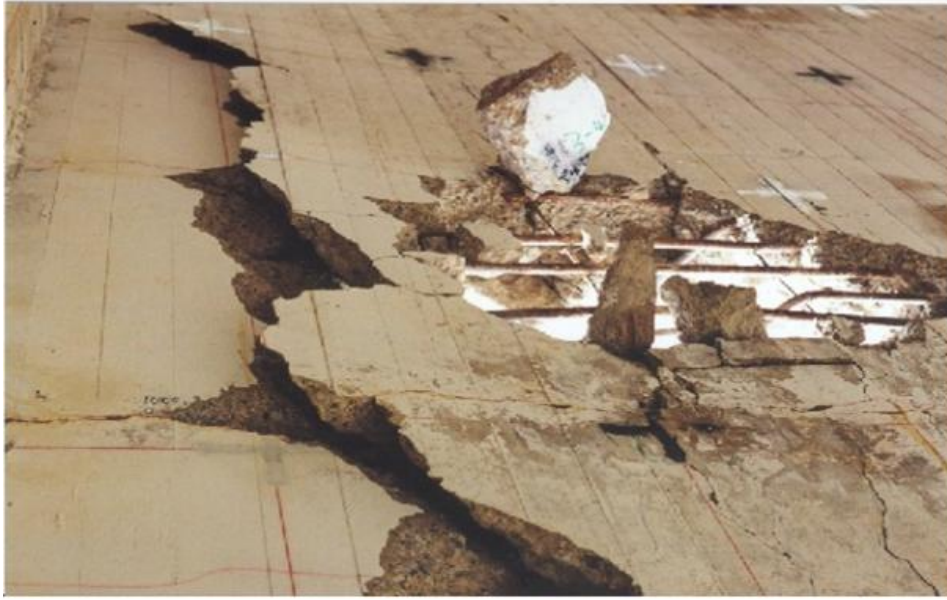

Figure 1. Punching Shear Failure in a Bridge Deck (Lu et al. 2020).

1.1. Steel Fiber Reinforced Concrete

Cement, gravel and sand aggregates, different kinds of fibers, and water make up the majority of Fiber Reinforced Concrete (FRC). Steel Fiber Reinforced Concrete (SFRC), which is the concrete produced by combining steel fiber with concrete, is another kind of fiber that is thought to originate from artificial sources in addition to fiber (Bompa and Elghazouli 2016).

1.2. Objectives and Scopes

On the basis of the above, experiments are conducted to determine how steel fiber affects the flat plate's residual strength. This goal will be accomplished by studying the effects of various load levels on SFRC flat plate:

- 1) Comparison of the punched shear behavior of the SFRC slab under various loads with the behavior of the slab at ambient conditions.
- 2) Examination of the impact of the volume percentage of steel fiber on punching shear capacity.

2. PUNCHING SHEAR PERSPECTIVE

Normal flooring slab, flat lintels, and the basis slabs underneath the pillar all experience punching shear failure. In pad fundamentals, when weight and depth are not crucially important, its contents are met by adequate depth (Sucharda et al. 2018).

- 1) Punching Shear in Reinforced Concrete Slabs
- 2) Calculations in Punching Shear
- 3) Design Considerations for Punching Shear in Slabs

2.1. EVALUATION OF SHEAR FAILURES

Shear failure in level slab are exceedingly serious and can cause full structures to collapse, not just a portion of the slab. Concerning the program that is being rummaged-sold for exclusive "headed" bars to project traditional links For patented products, controlled bars may have a more effective port than traditional links. This may allow for a relaxation of the spacing requirements for traditional relations or an increase in the amount of all-out shear that can be handled. Software shouldn't be used to support the use of conventional relations unless it is obvious that it is completely compliant for old-style linkages. The argument for the shear capability of a branded system is not based just on calculations but also on testing that benefits from the enhanced anchoring of such systems (Nassim, Bouafia, and Khalil 2015).

2.2. Workability Part of Flat Slab

Slabs seem to be carefully suitable for the majority of constructions, such as asymmetrical column setups, similar floor tiles that may occur, and stairways, among others. There are numerous advantages to smearing flat slabs, including thorough solution, flat fascia, and formability. Level 1 slabs provide engineers and architects a great deal of creative latitude despite their high cost. Flat slabs provide several benefits for the whole construction project, particularly for reducing bad setup and shortening build times, in addition to possible design and layout efficacy. If at all feasible, avoid using drop panels and make the most of the breadth of flat slabs. To preserve the advantages of level soffits for the ground surface, drop boards should be cast as a part of the column. The following characteristics should be taken into consideration while employing slab thickness to maximize equality (Bashandy et al. 2022):

- a) Procedure related to design
- b) Presence before absence of holes
- c) Significance of deflections
- d) Previous layout application knowledge

Types of Flat Slab Construction

Following are the kinds of flat slab building (Borkar, Dabhekar, Khedikar, and Jaju 2021):

- a) Simple level slab
- b) Flat slab with drop panels
- c) Flat slab with pillar heads
- d) Flat slab with both drop boards and column heads

Usages of Drop Boards (Borkar, Dabhekar, Khedikar, and Vaidya 2021):

It tends to increase the shear strength of the slab, as well as its negative immediate capacity. It stiffens the slab, reducing ricochet.

3. MIX DESIGN AND MATERIALS PROPERTIES

3.1. Mixture

The objective was to introduce a mixture, as shown in Table 1, because previous tests and research have demonstrated that fibers are more active when combined with fine aggregate.

Table 1. Mixture Design

Materials	Quantity per 1 m ³
Cement	453 (kg)
Sand, 0-4 mm	624 (kg)
Coarse aggregate, 22 mm	1242 (kg)
Water	181 (l)

3.2. Steel Fiber Properties

The experiment utilized Portland cement of the 53 grade, which is equivalent to (ASTM type I) while working with steel. Figure 3.1 depicts the geometry and forms used for the steel fiber, which is crimped and has a tensile strength of 1000 MPa. Specifically, the density of the fiber was 7.8 g/cm³. The dry ingredients (sand, gravel, cement, and silica fume) were first blended together in a Diagonal rotations mixer, which has three paddles for optimum mixing. It was necessary to combine the components to create a uniform blend, thus that was what was done. In this process, water is added gradually, and fibers are added last. After the fibers have been incorporated, the material is ready for casting. As can be seen in Figure 3.2, the mold was then generously lubricated to prevent the concrete sample from adhering to the mold and to facilitate its removal.



Figure 2. Steel Fiber



Figure 3. Mixer Type



Figure 4. Casting The Mold

3.3. Using Solid Work Method

Modeling is a representational example of a building's construction and the presentation of an issue system. A model is like the system it represents, but more simplistic. The primary goal of any model is to enable an analyst to foresee how different inputs will influence the output. The model should closely resemble the real system and incorporate as many salient elements as possible; yet, it shouldn't be so complex that it's hard to understand and test. The ideal design strikes a happy medium between robust functionality and user friendliness. Solid Work is the commercial software used to DRAW THE SAMPLES. Following the current method, the current work will be carried out as described in the following chapters. The following graphics, provided by Nguyen-Minh et al. in 2011, depict the model employed in this thesis.

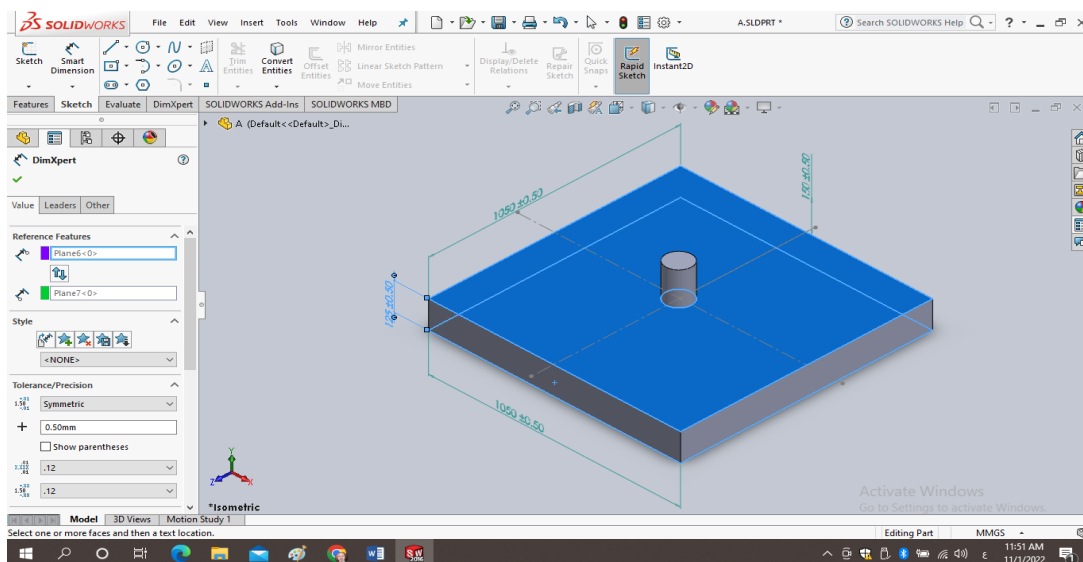

Figure 5. Model A

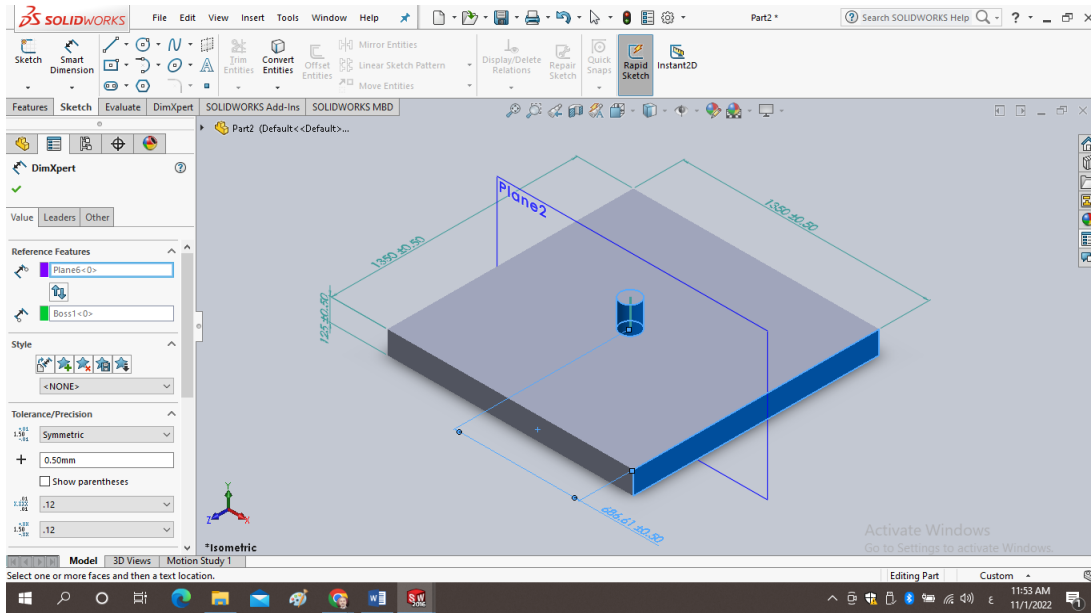

Figure 6. Model B

4. RESULTS

Table 2. Procedure of The study

		Type of test method	Type of mixing process	Type of SFRC
GROUP 1	A0	experimental and simulation test	Plane concrete	
	A1	Simulation test	Concrete with SFRC	hook and fiber
GROUP 2	B0	Experimental and simulation test	Plane concrete	
	B1	Simulation test	Concrete with SFRC	hook and fiber

Table 3. Samples Data Specification

		SFRC weight (Kg/m3)	Dimensions (mm)	Force KN
GROUP 1	A0	0	1050X1050X125	0 to 250
	A1	30	1050X1050X126	0 to 300

GROUP 2	B0	0	1350X1350X125	0 to 250
	B1	30	1350X1350X126	0 to 300

4.1. Results of Group A

Three-dimensional, miniature slab models were used to replicate the behavior of concrete slabs. Modal analysis is the method of investigating the dynamic properties of a system via the lens of the frequency domain. For instance, it can be used to learn more about how a mechanical structure reacts to stress. It is essential to take into account elements and a linear dynamic technique to discover displacement patterns while constructing a structure for loads. When something is in motion, it will take on a number of different "mode forms," or configurations. The patterns of displacement are frequently of great importance. A structure with N degrees of freedom will have N identical mode shapes. It is possible to create a novel displacement pattern by increasing the normalized displacement and superimposing it on top of existing mode shapes. Modal analysis simplifies difficult structures by breaking them down into a set of independent, single-degree-of-freedom systems. The photos below show the results of the study's initial testing of the slab structural shell.

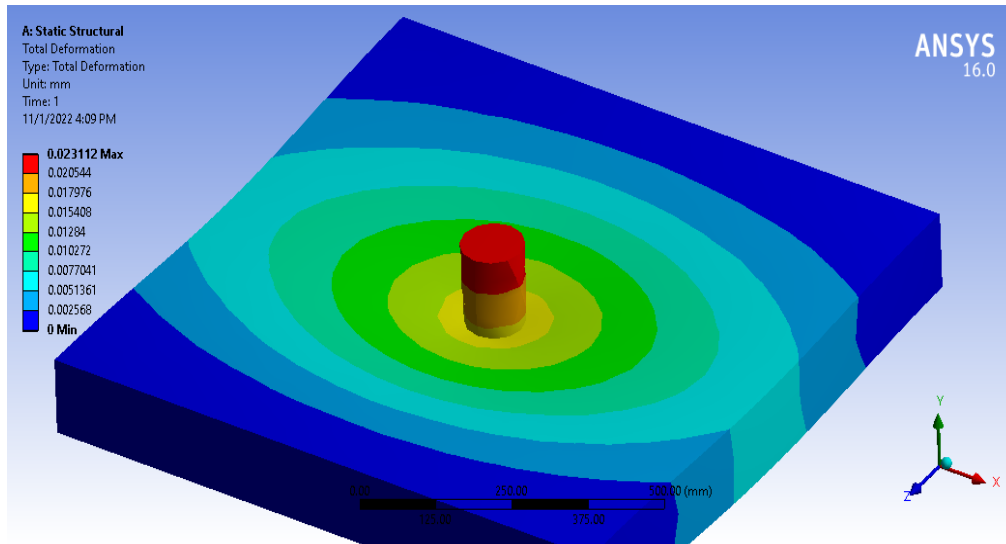

Figure 7. The Result of Load for The First Force

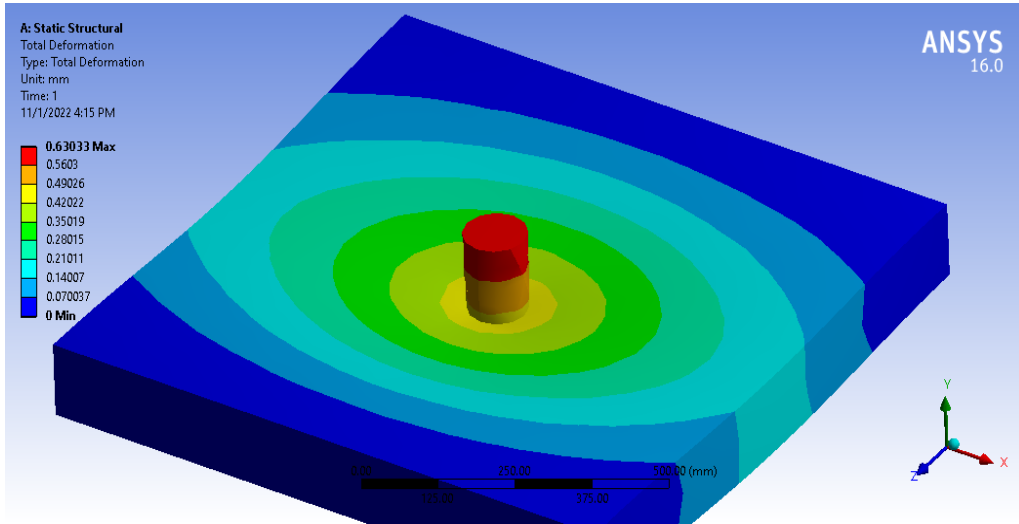

Figure 8. The Result of Load for The Second Force

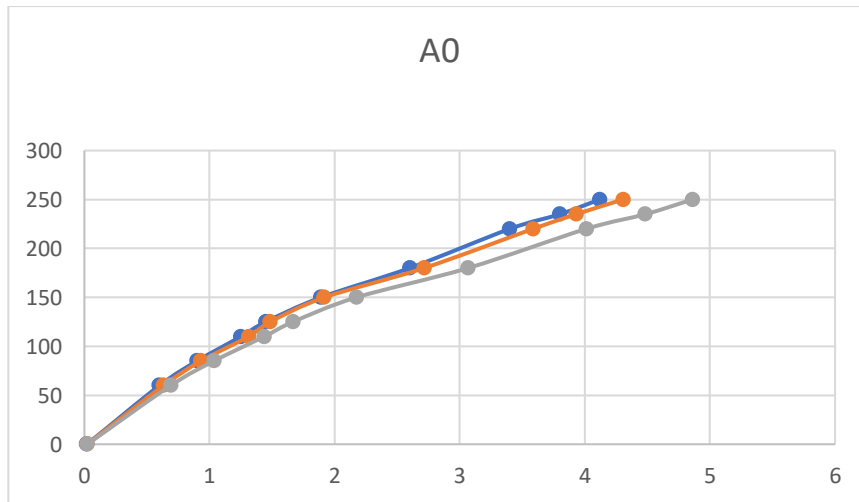

Figure 9. Results of A0 Displacement

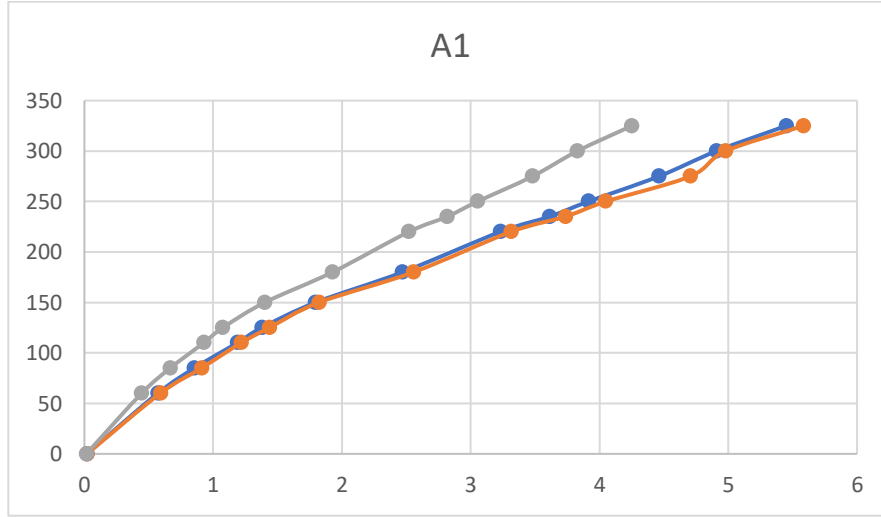

Figure 10. Results of A1 Displacement

4.2. Results of Group B

For the purpose of modeling the behavior of concrete slabs, three-dimensional, tiny slab models were utilized. The technique of analyzing the dynamic properties of a system via the lens of the frequency domain is referred to as modal analysis. For example, it can be used to gain a better understanding of how a mechanical structure responds when it is subjected to stress. When building a structure to support loads, it is critical to take into consideration a linear dynamic method in addition to the structure's components in order to identify patterns of displacement. When anything is moving, it will experience a variety of what are known as "mode forms," which can also be thought of as configurations. The patterns that are created by the displacement are frequently of utmost significance. If a structure has N degrees of freedom, then it will have N mode shapes that are similar to each other. By raising the normalized displacement and superimposing it on top of the existing mode shapes, it is feasible to generate a new displacement pattern. Modal analysis is a technique that can be used to simplify complex structures by decomposing them into a collection of autonomous systems with a single degree of freedom. The findings of the preliminary examination of the slab's structural shell can be seen in the photographs that are provided below.

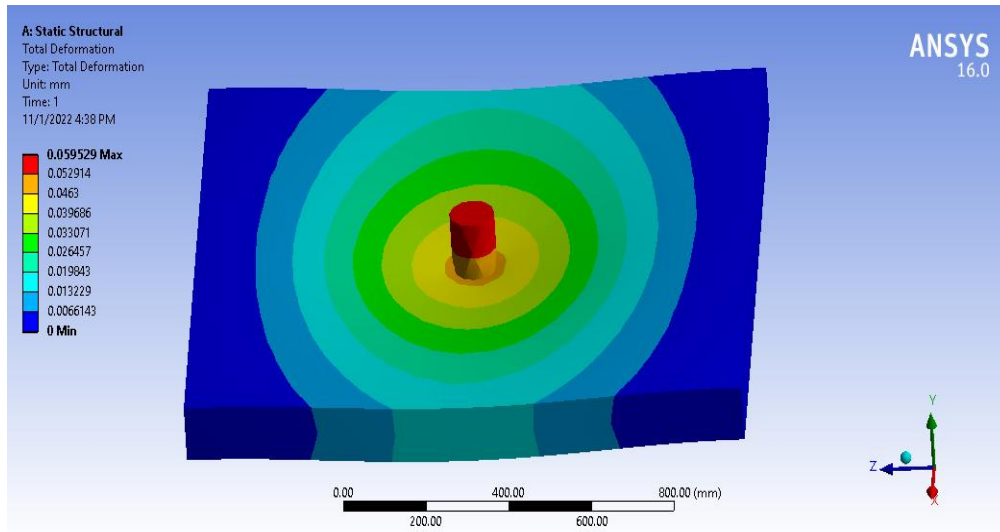

Figure 11. The Result of Load for The First Force

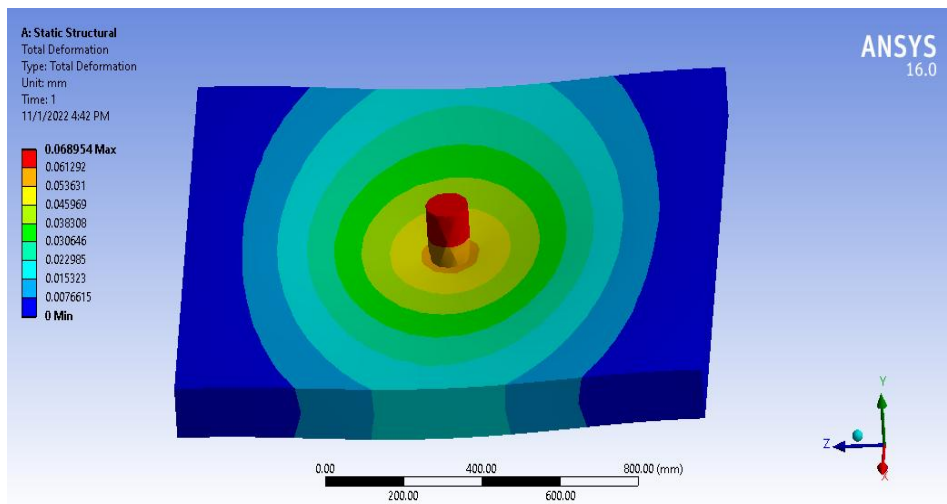

Figure 12. The Result of Load for The Second Force

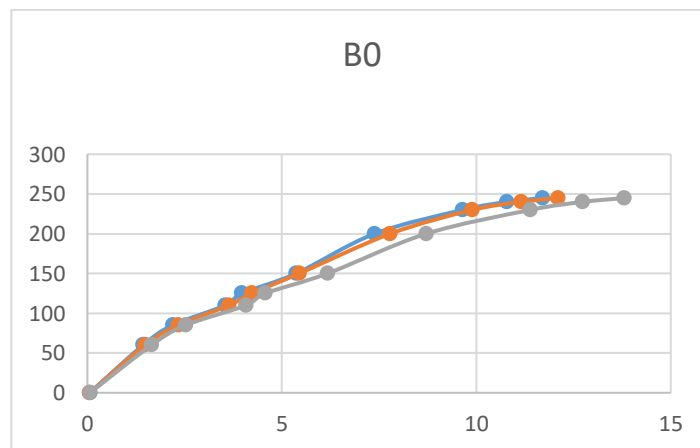

Figure 13. Results of B0 Displacement

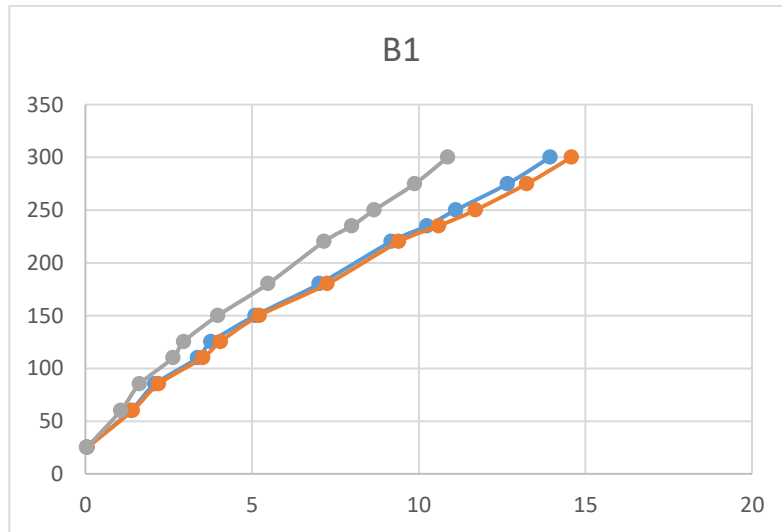

Figure 14. Results of B1 Displacement

Table 4. Properties for Reinforced and Concrete Compressive Stress.

The 28 days compressive strength of concrete f_c (MPa)	28.4
The 28 days compressive strength of concrete f_c (MPa) with 30Kg/m ³ SFRC	29.2
The 28 days compressive strength of concrete f_c (MPa) with 40Kg/m ³ SFRC	31.7
The 28 days compressive strength of concrete f_c (MPa) with 60Kg/m ³ SFRC	33.9

5. CONCLUSION AND RECOMMENDATION

It is not feasible to quantify the punching shear transfer processes quantitatively since the work is experimental. The influence of the fibers' length, shape, or the proportion of their diameter to length on the punching shear resistance of slabs are also not taken into consideration by these calculations. In actuality, these factors significantly affect the steel fibers' ability to bond to concrete, which in turn affects concrete strength, which in turn impacts the ability of SFRC slabs to withstand punching shear. The behavior of the slab is dominated by flexural deformation in the case of thin slabs with a high span-to-thickness ratio. In this case, this presumption could be accurate. While shear deformation has a major role in the behavior of slabs with a relatively low span-to-thickness ratio, shear deformation is less important. These assumptions may be drawn from the research's results based on the findings that were found:

- 1) The inclusion of steel fibers considerably increases the slabs' punching and shear resistance. Steel fibers with a fiber volume of 30 to 60 kg/m³ improve the punching shear resistance of the slabs in a manner that is directly proportional to the fiber volume.
- 2) The results of the FE analytical experiments that were performed for the two examples that were analyzed reveal that the load-deformation response and the behavior of the ultimate loads in concrete shear walls are in very good agreement with one another.
- 3) The optimal enchainment was achieved when steel fiber was applied to the concrete slabs when the slabs were being subjected to a high stress.
- 4) The optimal enchainment was achieved in both situations with the identical improvement behavior brought about by the addition of the steel fiber.

6. REFERENCES

- Bashandy, Alaa, Fatma Eid, Mohammed Arab, and Ahmed Elkassas.** 2022. "Resisting Punching Shear of Flat Slab." *International Journal of Advanced Research in Engineering & Technology* 9(February):19019.
- Bompa, D. V., and A. Y. Elghazouli.** 2016. "Structural Performance of RC Flat Slabs Connected to Steel Columns with Shear Heads." *Engineering Structures* 117(May):161–83. doi: 10.1016/j.engstruct.2016.03.022.
- Borkar, Shital, Kuldeep Dabhekar, Isha Khedikar, and Santosh Jaju.** 2021. "Analysis of Flat Slab Structures in Comparison with Conventional Slab Structures." *IOP Conference Series: Earth and Environmental Science* 822(1). doi: 10.1088/1755-1315/822/1/012049.
- Borkar, Shital, Kuldeep Dabhekar, Isha Khedikar, and Nalini Vaidya.** 2021. "Review on 'Comparative Study of Flat Slab Structure and Conventional Slab Structure.'" *IOP Conference Series: Materials Science and Engineering* 1197(1):012072. doi: 10.1088/1757-899x/1197/1/012072.
- Ilshat, Mirsayapov, Nikitin Georgy, and Khanbekov Midkhat.** 2020. "Strength of Reinforced Concrete Flat Slabs for Punching." *IOP Conference Series: Materials Science and Engineering* 890(1). doi: 10.1088/1757-899X/890/1/012076.
- Kearns, C. F., and G. M. McConnell.** 1989. "Structural Behaviour of Thin Planar and Curved Microconcrete Plates Reinforced Conventionally and with Steel Fibres." *Materials and Structures* 22(5):357–63. doi: 10.1007/BF02472506.
- Lu, Shasha, Mohammadreza Koopialipoor, Panagiotis G. Asteris, Maziyar Bahri, and Danial Jahed Armaghani.** 2020. "A Novel Feature Selection Approach Based on Tree Models for Evaluating the Punching Shear Capacity of Steel Fiber-Reinforced Concrete Flat Slabs." *Materials* 13(17). doi: 10.3390/ma13173902.

- Nassim, Kernou, Youcef Bouafia, and Belakhdar Khalil.** 2015. "Reliability and Punching Shear Resistance of Slabs in Non Linear Domain." *Gradjevinar* 67(11):1051–62. doi: 10.14256/JCE.1295.2015.
- Petkevicius, Mindaugas, and Juozas Valivonis.** 2010. "Analysis of Bending Capacity of Composite Steel-Concrete Slabs with Steel Fiber Reinforced Concrete." *10th International Conference Modern Building Materials, Structures and Techniques* (October):744–51.
- Samsudin, Amir Syafiq, Mohd Hisbany Mohd Hashim, Siti Hawa Hamzah, and Afidah Abu Bakar.** 2018. "Bending Strength of Steel Fibre Reinforced Concrete Ribbed Slab Panel." *Scientific Research Journal* 15(1):15. doi: 10.24191/srj.v15i1.9353.
- Sucharda, Oldrich, Martina Smirakova, Jana Vaskova, Pavlina Mateckova, Jan Kubosek, and Radim Cajka.** 2018. "Punching Shear Failure of Concrete Ground Supported Slab." *International Journal of Concrete Structures and Materials* 12(1). doi: 10.1186/s40069-018-0263-6.
- Zinn, Rainer, Michael Borgerhoff, Friedhelm Stangenberg, Christian Schneeberger, Javier Rodríguez, Luis Lacomá, Francisco Martínez, and Joaquín Martí.** 2014. "Analysis of Combined Bending and Punching Tests of Reinforced Concrete Slabs within IMPACT III Project." *Proceedings of the International Conference on Structural Dynamic , EURODDN 2014-Janua(August 2015):3533–40.*