



Journal name	International e-Journal of Educational Studies
Abbreviation	IEJES
e-ISSN	2602-4241
Founded	2017
Article link	http://doi.org/10.31458/iejles.1218321
Article type	Research Article
Received date	13.12.2022
Accepted date	09.03.2023
Publication date	21.03.2023
Volume	7
Issue	13
pp-pp	65-74
Section Editor	Prof.Dr. Suat ÜNAL
Chief-in-Editor	Prof.Dr. Tamer KUTLUCA
Abstracting & Indexing	EBSCO Education Full Text Database Coverage List H.W. Wilson Index Copernicus DRJI Harvard Library WorldCat SOBIAD
Article Name	Examination of the relationship between university students' perceptions regarding the chemistry laboratory environment and their chemistry laboratory anxiety

Author Contribution Statement

¹ Duygu BİLEN 

Assist. Prof. Dr.

Dicle University, Diyarbakır, Turkey

Conceptualization, literature review, methodology, implementation, data analysis, translation, and writing

Abstract

This research examined the relationship between university students' perceptions of the chemistry laboratory environment and their chemistry laboratory anxieties. The method of the study is correlational research. The study was conducted on 281 university students who enrolled in biology, physics, chemistry, and science teaching programs and took the chemistry laboratory course. The chemistry laboratory classroom environment scale and the chemistry laboratory anxiety scale were used to collect research data. The obtained data were analyzed via the structural equation model. The research results revealed that students' perceptions of the chemistry laboratory environment were a significant predictor for their chemistry laboratory anxiety. Furthermore, it was determined that 13% of the variance in laboratory anxiety was explained by the perceptions of the laboratory environment.

To cite this article:

Bilen, D. (2023). Examination of the relationship between university students' perceptions regarding the chemistry laboratory environment and their chemistry laboratory anxiety. *International e-Journal of Educational Studies*, 7 (13), 65-74. <https://doi.org/10.31458/iejles.1218321>

Copyright © IEJES

IEJES's Publication Ethics and Publication Malpractice Statement are based, in large part, on the guidelines and standards developed by the Committee on Publication Ethics (COPE). This article is available under Creative Commons CC-BY 4.0 license (<https://creativecommons.org/licenses/by/4.0/>)

Research Article**Examination of the Relationship between University Students' Perceptions Regarding the Chemistry Laboratory Environment and their Chemistry Laboratory Anxiety***Duygu BİLEN¹ **Abstract**

This research examined the relationship between university students' perceptions of the chemistry laboratory environment and their chemistry laboratory anxieties. The method of the study is correlational research. The study was conducted on 281 university students who enrolled in biology, physics, chemistry, and science teaching programs and took the chemistry laboratory course. The chemistry laboratory classroom environment scale and the chemistry laboratory anxiety scale were used to collect research data. The obtained data were analyzed via the structural equation model. The research results revealed that students' perceptions of the chemistry laboratory environment were a significant predictor for their chemistry laboratory anxiety. Furthermore, it was determined that 13% of the variance in laboratory anxiety was explained by the perceptions of the laboratory environment.

Keywords: Chemistry laboratory, chemistry laboratory environment, chemistry laboratory anxiety

1. INTRODUCTION

When science teaching is examined in terms of its content and pedagogy, it is seen that new standards for science education have been developed and adopted (National Research Council, 1996; 2000). The educational science laboratory is the most striking one among these standards. In science laboratories, students can understand and explore nature in a more tangible way through experimentation and observation by using authentic, concrete materials (Hofstein & Mamlok-Naaman, 2007). To achieve this, of course, there are some certain principles need to be considered during laboratory activities. Firstly, students should actively participate to the process. They should be aware of the problem handled, understand the rationale of the experiment, develop alternative hypotheses to solve the problem, and test these hypotheses by collecting and interpreting data (Aladejana, 2006; Hung & Chin, 1988; Mayer, 2003). Besides, the practices carried out in the laboratory should be qualified enough to arouse students' interest, and the creativity of the students should be rewarded, their questioning skills should be encouraged, and they should be given a certain duration to develop thought-provoking answers and dialogues (Instructional Philosophy, 2004). Following these principles in a laboratory teaching is important to provide the students with meaningful learning.

As a complementary to science education, with laboratory practices, students develop their skills of creative and scientific thinking, problem solving, and observing and interpreting the events, collecting, and analyzing data, thus they can improve their scientific knowledge (Taitelbaum, Mamlok-Naaman, Carmeli, & Hofstein, 2008). That is, through laboratory practices, students can raise questions, plan, and perform experiments, collect data using appropriate tools and techniques, make

Received Date: 13/12/2022

Accepted Date: 09/03/2023

Publication Date: 21/03/2023

To cite this article: Bilen, D. (2023). Examination of the relationship between university students' perceptions regarding the chemistry laboratory environment and their chemistry laboratory anxiety. *International e-Journal of Educational Studies*, 7 (13), 65-74. <https://doi.org/10.31458/iej.1218321>

¹ Assist. Prof. Dr., Dicle University, Diyarbakır, Turkey, dbk1976@gmail.com

* Corresponding Author e-mail adress: dbk1976@gmail.com

critical and logical connections between the gathered data and predictions/presuppositions about the results of a scientific experiment, and they develop their ability of structuring, analyzing, discussing and sharing scientific arguments (Adadan, 2015). According to Hodson (1996), there are three types of skills acquired during laboratory activities. The first one is to ensure the application of science as a main source of learning intellectual and theoretical knowledge. The second one is to learn science directly from nature and through using scientific methods. The third one, on the other hand, is to concentrate on performance, in other words, to specialize in scientific research. Hofstein and Mamlok-Naaman (2007) stated that laboratory practices increase students' problem-solving and scientific processing skills, and help them to develop positive attitudes towards science education. Singer, Hilton and Schweinger (2005) examined the impact of laboratory experiences on students' affective skills and revealed that laboratory experiences increase students' interest in science and improve their ability to make scientific interpretations from the research.

1.1. Laboratory Environment

There are certain factors that play important roles on the effectiveness of laboratory practices and of all the factors, laboratory environment has a special place. The absence of proper laboratory environment is one of the most serious problems that restrict the efficiency of science teaching. A laboratory environment has two aspects: (i) physical environment, and (ii) non-physical environment. Physical environment of a laboratory includes the features such as location of the laboratory, lightning, furniture design, infrastructure, ventilation, accessibility of the devices, etc. The laboratories that are not furnished in accordance with today's update technologies, that don't meet the students' potential needs, or that don't have adequate devices (i.e., those with old, broken/or inadequate materials) are the primary obstacles to the practical teaching of science lessons in the laboratory environment. Such kinds of situation causes that laboratory practices are often neglected and that most of the science lessons are conducted in classroom environment (Güzel, 2002).

The non-physical aspect of the laboratory environment, on the other hand, includes the personality of the teacher, the student-teacher relationship, classroom management ability of the teacher, the rules to be followed in the laboratory, the clarity of the said rules and how these rules are determined (Silberman, 1973; Wilson, 1996). Quek, Wong and Fraser (1998) investigated 'learning environments', in general, and 'laboratory environment', in particular, in following five dimensions:

Student solidarity	Each student helps the others based on their level of knowledge
Open-mindedness	Experiencing laboratory activities with a variety of open-ended approaches
Integration	In the lack of laboratories, supporting the classes with laboratory activities
Rule transparency	Formally-rule surrounded behaviors in laboratories
Materials	Sufficiency of the devices and equipment

Figure 1. The dimensions of laboratory environment

In some studies that focus on the nonphysical environment in the laboratories found that poorly planned laboratory activities (Erdem, 2011; Güneş, 2007) are not efficient, and they can lead to confusion (Hodson, 1990) as well as disrupting classroom discipline (cited in Feyzioglu, Demirdağ, Akyıldız, & Eralp, 2012). Undoubtedly, in addition to the physical and non-physical laboratory environment, the emotional characteristics of the students also play a decisive role on the practices in the laboratory environment. One of the students' emotional characteristics that affect the quality of

teaching services in the laboratory environment is the “laboratory anxiety”. As a matter of fact, the previous studies (e.g., Uşaklı & Akpınar, 2015; Ünal & Kılıç, 2016) have shown that students have anxieties while performing an experiment in a laboratory environment.

1.2. Laboratory Anxiety

Freud (1969) defines anxiety as “an undesirable, unpleasant feeling that can be experienced anytime and anywhere”. Wynstra (1990), on the other hand, defines science anxiety as a diffuse, vague fear of learning science. Eddy (1996) coined the term of chemophobia and ascertained that students were anxious while carrying or mixing unfamiliar chemicals. Bowen (1999) was the first to use the term of chemistry laboratory anxiety and developed the chemistry laboratory anxiety scale. This scale emerged from the idea that it would not be enough to focus only on the anxiety of science and chemistry but that laboratory anxiety should be handled separately (Azizoğlu & Uzuntiryaki, 2006). The scale investigates students’ anxieties about the chemistry laboratory from a cognitive perspective and deals with students’ use of their causal and experimental skills to comprehend chemical concepts. Uşaklı and Akpınar (2015) developed an “anxiety scale for science laboratory” with the purpose of determining students’ anxiety about laboratory and to develop suggestions for better and more efficient laboratory classes. Sert-Çıbık and İnce-Aka (2021), on the other hand, examined the relationship between students’ anxiety of chemistry laboratory and their attitudes towards laboratory skills from various variables.

1.3. The Objective of the Study

The unique atmosphere of the laboratory environment (e.g., students and the instructors need to wear uniforms, the dangerous properties of the materials to be exploited in the experiment are not known exactly, and the necessity of preparing the experimental setup with peers in front of the instructor) may cause performance anxiety among the students. That is, quite different from the classroom environment, with its unique atmosphere, the laboratory environment can trigger negative feelings as uneasiness, reluctance, and failure in students. Hence, it is thought that students’ perceptions of the science laboratory environment play an effective role on their laboratory anxiety. However, considering both the laboratory environment and laboratory anxiety are multidimensional, it may only be possible to fully grasp the level and direction of the relationship between these two variables through empirical studies on the subject. From this point of view, this study aimed to examine the relationship between students' perceptions of the laboratory environment and laboratory anxiety. Although the studies in the literature show that the learning environment is effective on anxiety and other affective characteristics (e.g., Karşlı & Ayas, 2013; Lee & Fraser, 2006; Wong, Young & Fraser, 2006), no study has been found in the literature that directly examines the relationship between perceptions of the chemistry laboratory environment and chemistry laboratory anxiety. In this regard, it is believe that the study will contribute to the literature.

2. METHOD

2.1. Research Design

Since, the relationship between university students' perceptions of the chemistry laboratory course and their laboratory concerns is examined this study is a correlational research one. In correlational research studies, it is aimed to determine whether two or more variables are related to each other and to determine the level of the relationship (İlhan & Gezer, 2021).

2.2. Study Group

The selection of individuals or circumstances that satisfy predefined criteria is known as criterion sampling. That is to say, in this sampling technique data is gathered from the participants who have the specified criterions (Gezer, 2021). The variable taken as a criterion in the current study was to have taken the chemistry laboratory course. So, the sampling strategy used in the study was criteria sampling. Consequently, the study was conducted on 281 university students who took the chemistry laboratory course during the Fall Term of the 2018–2019 academic year and were attending the biology, physics, chemistry, and science teaching programs at Dicle University's Ziya Gökalp Education Faculty in Turkey.

2.3. Data Collection Procedures

The research data were collected using the general chemistry laboratory classroom environmental scale and the chemistry laboratory anxiety scale.

2.3.1. General Chemistry Laboratory Classroom Environmental Scale

This scale was developed by Moos and Trickett, and adapted into Turkish by Doğan, Atılgan and Demirci (2003). The scale has a five-point Likert-type scale ranging from Always (5) to Never (1). In the adaptation study; the reliability coefficient of the scale, consisted of 35 items classified into five dimensions, calculated as .85, and the reliability coefficients of the subscales were reported to vary between .61 and .87. The sub-dimensions of the scale, the reliability coefficients for each dimension for the measurements of the current research, and sample items are presented in Table 1.

Table 1. Sample items and reliability coefficients of the sub-dimensions of the general chemistry laboratory classroom environment scale

Scale Dimensions	Number of Items	Sample Item	Reliability Coefficient
Proximity	7	I get along well with the students in my class in the lab	.73
Open- mindedness	7	I have the opportunity to do research on chemistry subjects I am interested in laboratory classes.	.59
Integration	7	The studies I do in my General Chemistry classes are compatible with the laboratory activities.	.85
Clarity in rules	7	There are clear rules that guide the activities I carry out in my lab classes.	.71
Physical Environment	7	I find the lab crowded while doing the experiment	.70

As can be seen in in Table 1, the Cronbach alpha coefficients vary between .59 and .85. In general, coefficients of 70 and above are considered sufficient for the reliability of the measures (Erkuş, 2003). However, the number of items in a scale significantly affects the internal consistency coefficient and it is difficult to reach high reliability values in scales with few items (Urbina, 2004). For this reason, values of .50 and above in scales with a small number of items can be considered as the lower limit for reliability (Raines-Eudy, 2000). In this respect, the data obtained in this study by means of the general chemistry laboratory classroom environment scale can be considered reliable.

2.3.2. Chemistry Laboratory Anxiety Scale

This scale was created by Bowen (1999) and adapted into Turkish by Azizoğlu and Uzunıryaki (2006). The scale was designed in five-point rating from Strongly Agree (5) to Strongly Disagree (1), contains 20 items and consists of four dimensions. The reliability coefficients calculated for the sub-dimensions were found to vary from 0.86 to 0.88. Table 2 shows the sub-dimensions of the scale, the calculated reliability coefficients in the present study for each dimension, and sample items.

Table 2. Sample items and reliability coefficients of the sub-dimensions of the chemistry laboratory anxiety scale

<i>Scale Dimensions</i>	<i>Number of Items</i>	<i>Sample Items</i>	<i>Reliability coefficient</i>
Working with lab equipment and chemicals	6	I feel at ease using the chemicals and the equipment in the chemistry laboratory.	.81
Working with other students	4	It makes me feel nervous to work with other students in the chemistry lab	.72
Data collection	6	While working in the chemistry lab, recording the data I need creates tension for me.	.81
Having adequate time	4	I feel worried if there is enough time to finish the lab	.77

Table 2 demonstrates that the reliability coefficients range between .72 and .81. When the estimated reliability coefficients are considered, it can be stated that the data acquired using the chemistry laboratory anxiety scale are reliable.

2.4. Data Analysis

Before starting to analyze the data, data was scrutinized to see whether there was missing values in the data set and no missing data was found. Then, the distribution of the research data was examined. To this end, the skewness and kurtosis coefficients were analyzed. Table 3 provides the obtained skewness and kurtosis coefficients.

Table 3. The skewness and kurtosis coefficients of the research data

<i>Scale</i>	<i>Dimensions</i>	<i>Skewness</i>	<i>Kurtosis</i>
General	Proximity	-.22	-.09
Chemistry Laboratory	Open endedness	-.22	-.07
Classroom	Integration	-.55	-.03
Environmental Scale	Clarity of Rules	-.38	.38
	Physical Environment	-.09	.04
Chemistry Lab Anxiety Scale	Working with lab materials and chemicals	-.05	-.41
	Working with other students	.37	-.36
	Data Collection	.14	-.56
	Having adequate time	.26	-.36

Table 3 shows that all of the skewness and kurtosis values are in the range of ± 1 . In a perfectly symmetrical normal distribution, the skewness and kurtosis coefficients are equal to 0 (Bachman, 2004). However, the skewness coefficients in the range of ± 1 are interpreted as the data do not show a significant deviation from the normal distribution (Büyüköztürk, 2010). In this respect, it can be said that the research data display a normal distribution.

After it was determined that the data had a normal distribution, the data analysis process was initiated. Correlation analysis (Pearson product-moment correlation) and structural equation modeling were employed to examine the relationship between chemistry laboratory classroom environment and chemistry laboratory anxiety. Structural equation model analyzes were carried out based on the maximum likelihood method, since the data were found to be in accordance with the normal distribution. During the analysis, while determining the compatibility level between the tested model and the data, the fit indices were looked into. Table 4 illustrates the acceptable values for the fit indices checked over. While SPSS 21.0 package program was utilized for the correlation analysis, LISREL 8.54 software was operated for performing structural equation model analysis.

Table 4. Acceptable criteria for the fit indices analyzed in the study

Analyzed fit indexes	χ^2/df^a	RMSEA ^b	SRMR ^b	CFI ^c	IFI ^c	RFI ^c	NFI ^c	NNFI ^c	GFI ^c
Criteria Values	< 5	< .10	< .08	> .95	> .95	> .95	> .95	> .95	> .95

^a Aksu, Eser & Güzeller (2017), ^b Meyers, Gamst & Guarino (2006), ^c İlhan & Çetin (2014)

3. FINDINGS

The research findings are presented below. First, correlation analysis was applied on the total scores obtained from the general chemistry laboratory classroom environment scale and chemistry laboratory anxiety scales, and the relationship between the two variables was found to be statistically significant [$r = -.31, p < .01$]. Then, structural equation model analysis was applied to determine the predictive power of students' perceptions of the general chemistry laboratory classroom environment to predict their chemistry laboratory anxiety. Findings of structural equation modeling are displayed in Figure 2.

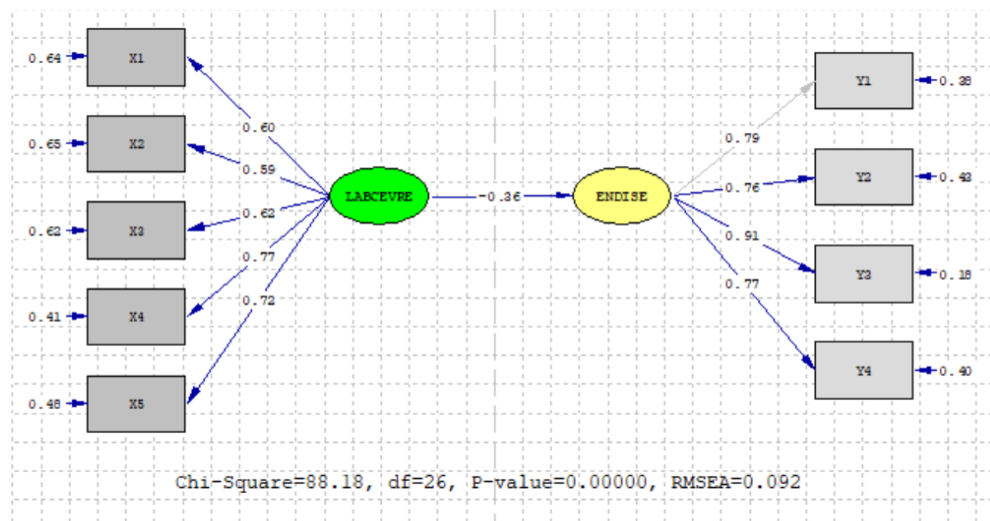

Figure 2. Structural equation model of the relationship between perceptions of the chemistry laboratory environment and laboratory anxiety

When the fit indices of the tested model, the following results were obtained: $\chi^2/df = 3.39$, RMSEA = .092, SRMR = .076, CFI = .95, IFI = .95, RFI = .91, NFI = .94, NNFI = .93 and GFI = .93. Based on cut-off points regarding to these findings, it can be concluded that the model established between the general chemistry laboratory classroom environment and laboratory anxiety is confirmed by the research data. When the coefficients of the model were examined, the equation for predicting the chemistry laboratory anxiety of the students with their perceptions of the general chemistry laboratory classroom environment was found to be:

$$\begin{aligned}
 (\text{Laboratory anxiety}) &= -0.36^* (\text{General chemistry Lab. environment}), \text{Error variance} = .87, R^2 = .13 \\
 & \quad (.070) \qquad \qquad \qquad (.12) \\
 & \quad -5.23 \qquad \qquad \qquad 7.39
 \end{aligned}$$

As seen in the equation above, 13% of the variance in students' laboratory anxiety can be explained by their perceptions of the general chemistry laboratory classroom environment.

4. DISCUSSION and CONCLUSION

In this study, the relationship between university students' perceptions of the chemistry laboratory environment and their laboratory anxiety was investigated. As a result of the study, it was found that the perception of the laboratory environment is a significant predictor of laboratory anxiety. Although there is no study in the literature that directly deals with the relationship between laboratory anxiety and perception of the laboratory environment, there are studies that can indirectly support the current research findings. Wong, Young and Fraser (2006), investigated the relationship between middle school students' perceptions of the chemistry laboratory environment and their attitudes towards the chemistry. They established that students' perceptions of the chemistry laboratory environment is an important variable that shapes students' attitudes towards the chemistry. Similarly, Lee and Fraser (2001), found a statistically significant relationship between students' perceptions of the laboratory environment and their attitudes towards science in the study they conducted on 437 high school students in Korea. The results of the studies of Wong et al., (2006) and Lee and Fraser, (2001) are compatible with the findings of this study in that they indicate that perception of the laboratory environment is related significantly with students' affective traits.

The results of studies examining the relationship between the perception of laboratory environment and academic achievement show indirect similarity with the findings of the present study. Olubu (2015) investigated how secondary school students' perceptions of the laboratory learning environment affect their academic performance and determined that students' perception of the laboratory environment had a significant effect on their chemistry performance. Aladejana and Aderibigbe (2007) investigated high school students' perceptions of the science laboratory environment and its effects on their learning outcomes. They handled students' perception of the science laboratory environment under five dimensions, and determined that all dimensions were positively and significantly related to academic achievement. As can be seen, the studies by both Olubu (2015) and Aladejana (2006) do not directly address laboratory anxiety. However, considering the fact that there is a significant relationship between the perceptions of the laboratory environment and learning outcomes in the studies cited above, it can be stated that the results of the studies just mentioned are partially analogous to the findings of the current study.

The findings obtained in this research are compatible with the results obtained in studies conducted in other disciplines. Haertel, Walberg and Haertel, (1981) investigated the correlation between social and psychological characteristics of the learning environment and cognitive and affective learning outcomes and analyzed the results of 12 studies conducted in eight different disciplines. The results of the analysis proved that there was a significant relationship between the learning environment and learning outcomes. In the studies conducted by Miller and Mitchell (1994), Tooke and Lindstrom (1998), Shields (2006), and Taylor and Fraser (2013), it was determined that the classroom environment is an effective variable on mathematics anxiety. Henderson, Fisher and Fraser, (1995) examined the relationship between students' perceptions of the learning environment and their attitudes towards the classroom and in-class discussions in the 'environmental science course', and they ascertained that there was a significant relationship between said variables. In their study on secondary school students in Australia, Dorman, Fisher and Waldrip, (2006) examined the relationships between students' perceptions of the science lesson environment, their attitudes towards the course and their academic self-efficacy. Fia et al., (2022) conducted research on the causes, effects, and management of science anxiety in 337 high school students. It was revealed that the participants experienced science homework, attitudes towards science, fear when entering science class, and anxiety about solving science problems. As a result of the study, it was determined that 49% of the variance of the attitude towards the course and 45% of the variance of the academic efficacy were related to the students' perceptions of the science course environment. These abovementioned results

indicate that the research findings are compatible with the results of the studies conducted in other disciplines.

5. SUGGESTIONS for FURTHER RESEARCH

As a result of the research, it was determined that 13% of the total variance of laboratory anxiety is related to students' perceptions of the general chemistry laboratory classroom environment. This means that the proper design of the chemistry laboratory environment will contribute to the prevention of laboratory anxiety. Therefore, in order to decrease laboratory anxiety, a suitable physical environment must be created in the laboratory, the rules to be followed must be clearly defined, a proper atmosphere where students can work collaboratively, a democratic environment should be provided to students in which they can study the subjects they are interested in. Additionally, it should be paid attention that the experiments conducted in the laboratory environment should be compatible with theoretical chemistry courses.

This research is a correlational one. Although correlational studies can reveal the direction and strength of the relationship between variables, they limit the interpretations that can be made about the causality of the results. In this respect, it is important to carry out experimental studies to determine the effect of perceptions about the laboratory environment on laboratory anxiety for more precise inferring about causality. In addition, the data of the present study were collected using self-report instruments. Further studies on the subject should use different data collection methods such as making observations in the laboratory environment, conducting interviews with the instructors of laboratory courses and with the students taking this course, asking students to keep reflective diaries and examining these diaries.

Acknowledgement

This study is the extended version of the oral presentation given by the author at the XII International Congress of Educational Research conference in Rize, Turkey in 2019.

6. REFERENCES

- Adadan, E. (2015). Kimya öğretiminde yönlendirilmiş araştırmaya dayalı laboratuvar uygulamaları [Laboratory practices based on directed research in chemistry teaching]. In A. Ayas & M. Sözbilir, (Ed.), *Kimya öğretimi [Chemistry teaching]*, (pp. 27–48). Ankara, Turkey: Pegem Akademi Yayınevi.
- Aksu, G., Eser, M. T. & Güzeller, C. (2017). *Açımlayıcı ve doğrulayıcı faktör analizi ile yapısal eşitlik modeli uygulamaları [Structural equation model applications with exploratory and confirmatory factor analysis]*. Ankara, Turkey: Detay Yayıncılık.
- Aladejana, F. O. (2006). Concept of teaching. In O. J Ehindero, & F. O. Aladejana (Eds.), *Introduction to the teaching profession*, (12–19). Lagos: Literamed Publications Ltd.
- Aladejana, F. O. & Aderibigbe, O. (2007). Science laboratory environment and academic performance, *Journal of Science Education and Technology*, 16(6), 500-506. <https://doi.org/10.1007/s10956-007-9072-4>
- Azizoğlu, N. & Uzuntiryaki, E. (2006). Chemistry laboratory anxiety scale. *Hacettepe University Journal of Education*, 30(30), 55-62. http://efdergi.hacettepe.edu.tr/shw_articl-725.html
- Bachman, L. F. (2004). *Statistical analyses for language assessment book*. Cambridge: Cambridge University.
- Bowen, C. W. (1999). Development and score validation of a chemistry laboratory anxiety instrument (CLAI) for college chemistry students. *Educational and Psychological Measurement*, 59(1), 171–185. <https://doi.org/10.1177/0013164499591012>
- Büyüköztürk, Ş. (2010). *Sosyal bilimler için veri analizi el kitabı [Manual of data analysis for social sciences]*. Ankara, Turkey: Pegem Akademi Yayınevi.
- Doğan, D., Atılgan, H. & Demirci, B. (2003). Genel kimya laboratuvarı sınıf çevresi ölçeği-gerçek formunun uyarlama çalışması. *Eğitim Araştırmaları*, 4(12), 56-63.

- Dorman, J. P., Fisher, D. L. & Waldrup, B. G. (2006). Classroom environment, students' perceptions of assessment, academic efficacy and attitude to science: A LISREL analysis. In D. Fisher & M. S. Khine, (Ed.), *Contemporary approaches store search on learning environments: World views* (pp. 1-28). Singapore: World Scientific.
- Eddy, R. M. (1996). *Chemophobia in the college classroom: Extent, sources and student characteristics*. (Doctoral dissertation, University of Pittsburgh). <https://doi.org/10.1021/ed077p514>
- Erdem, A. R. (2011). Sınıf yönetimi [Classroom management]. In R. Sarpkaya, (Ed.), *Sınıf disiplini ve kuralları [Class discipline and rules]* (pp. 81-117). Ankara, Turkey: İhtiyaç Yayıncılık.
- Erkuş, A. (2003). *Psikometri üzerine yazılar [Essays on psychometry]*. Ankara: Türk Psikologlar Derneği Yazıları.
- Feyzioğlu, B., Demirdağ B., Akyıldız, M. & Eralp A. (2012). Constructing a perception scale: Chemistry teachers' perceptions on laboratory applications. *Journal of Turkish Science Education*, 9(4), 44-63.
- Fia S. D., Fosu-Ayarkwah C., & Obuobi-Ayim T. (2022). Causes, effects and management of science anxiety among senior high school students in Old Tafo municipality of Ghana. *Open Journal of Psychology*, 2(1), 46–57. <https://doi.org/10.31586/ojp.2022.384>
- Freud, S. (1969). *The problem of anxiety*. New York: Norton Publishing.
- Gezer, M. (2021). Örneklem seçimi ve örnekleme yöntemleri. B. Çetin, M. İlhan, & M. G. Şahin (Eds.), *Eğitimde araştırma yöntemleri: Temel kavramlar, ilkeler ve süreçler* (s. 133–159). Ankara, Turkey: Pegem Akademi.
- Güneş, F. (2007). *Yapılandırmacı yaklaşımla sınıf yönetimi [Classroom management with a constructivist approach]*. Ankara, Turkey: Nobel Yayınevi.
- Güzel, H. (2002, September). *Fen bilgisi öğretmenlerinin laboratuvar kullanımı ve teknolojik yenilikleri izleme eğilimleri [Science teachers' use of laboratories and trends in monitoring technological innovations]*. Paper presented at the 5th Science and Mathematics Education Congress, Ankara, Turkey.
- Haertel, G. D., Walberg, H. J., & Haertel, E. H. (1981). Socio-psychological environments and learning: a quantitative synthesis. *British Educational Research Journal*, 7(1), 27–36.
- Henderson, D., Fisher, D. L. & Fraser, B. J. (1995). *Gender differences in biology students' perceptions of actual and preferred learning environments*. Paper presented at the annual meeting of the National Association for Research in Science Teaching, San Francisco, CA.
- Hodson, D. (1990). A critical look at practical work in school science. *School Science Review*, 70, 33-40.
- Hodson, D. (1996). Laboratory work as scientific method: Three decades of confusion and distortion. *Journal of Curriculum Studies*, 28 (2), 115-135. <https://doi.org/10.1080/0022027980280201>
- Hofstein, A. & Mamlok-Naaman, R. (2007). The laboratory in science education: The state of art. *Chemistry Education Research and Practice*, 8, 105-107.
- Hung, F. U. & Chin, A. K. (1988). Sharing of experiences-application of discovery method to teaching. *Education Journal*, 16(1), 85–96.
- İlhan, M. & Çetin, B. (2014). Comparing the analysis results of the structural equation models (SEM) conducted using LISREL and AMOS. *Journal of Measurement and Evaluation in Education and Psychology*, 5(2), 26–42.
- İlhan, M. & Gezer, M. (2021). Araştırmaların sınıflandırılması. B. Çetin, M. İlhan, & M. G. Şahin (Eds.), *Eğitimde araştırma yöntemleri: Temel kavramlar, ilkeler ve süreçler* (s. 101–132). Pegem Akademi.
- Karlı, F. & Ayas, A. (2013). Farklı kavramsal değişim yöntemleri ile alternatif kavramları gidermek ve bilimsel süreç becerilerini geliştirmek mümkün müdür? Elektrokimyasal piller örneği [Is it possible to eliminate alternative conceptions and to improve scientific process skills with different conceptual change methods? 'An example of electrochemical cells']. *Bilgisayar ve Eğitim Araştırmaları Dergisi [Journal of Computer and Education Research]*, 1(1), 1-26.
- Lee, S. S. U. & Fraser, B. J. (2001, March). High school science classroom learning environments in Korea. *Paper presented at the annual meeting of the National Association for Research in Science Teaching*, St. Louis.
- Mayer, R. E. (2003). *Learning and instruction*. Pearson Education, Inc, Upper Saddle River, 287–288.

- Meyers, L. S, Gamst, G. & Guarino, A. J. (2006). *Applied multivariate research: Design and interpretation*. London: Sage Publishing.
- Miller, L. D. & Mitchell, C. E. (1994). Mathematics anxiety and alternative methods of evaluation. *Journal of Instructional Psychology*, 21(4), 353-359.
- Moos, R. H. & Trickett, E. J. (1987). *Classroom environment scale manual (2nd Ed.)*. Palo Alto, CA: Consulting Psychologists Press.
- National Research Council, (1996). *National science education standarts*. Washington, DC: National Academy Press.
- National Research Council, (2000). *Inquiry and the national science education standarts*. Washington, DC: National Academy Press. <https://doi.org/10.17226/9596>
- Olubu, O. M. (2015), Effects of laboratory learning environment on students' learning outcomes in secondary school chemistry. *International Journal of Arts & Science*, 8(2), 507-525.
- Quek, C. L., Wong, F. L. & Fraser, B. J. (1998, April). Teacher–student interaction among gifted chemistry students in Singapore secondary schools. *Paper presented at the Annual meeting of the National Association for Research in Science Teaching*, San Diego.
- Raines-Eudy, R. (2000). Using structural equation modeling to test for diffeferential reliability and validity: An empsirical demonstration. *Structural Equation Modeling*, 7(1), 124–141. https://doi.org/10.1207/S15328007SEM0701_07
- Sert-Çibik, A. & İnce–Aka, E. (2021). Student views on attitudes towards chemistry laboratory skills. *Online Science Education Journal*, 6(2), 100-113.
- Shields, D. J. (2006). Causes of mathematics anxiety. The student perspective. (Doctoral dissertation, Indiana University of Pennyslvania, Indiana).
- Silberman, C.E. (1973). *The open classroom readers*. New York: Random Press.
- Singer, S., Hilton, M. & Schweinger, H. (2005). Needing a new approach to science labs. *The Science Teacher*, 72(7), 10.
- Taitelbaum, D., Mamlok-Naaman, R., Carmeli, M. & Hofstein, A. (2008). Evidence for teachers' change while partipating in a continuous professional development programme and implementing the inquiry approach in the chemistry laboratory, *International Journal of Science Education*, 30(5), 593-617. <https://doi.org/10.1080/09500690701854840>
- Taylor, B. A. & Fraser, B. J. (2013). Relationships between learning environment and mathematics anxiety. *Learning Environments Research*, 16(2), 297–313.
- Tooke, D. J. L. & Lindstrom, L. C. (1998). Effectiveness of a mathematics methods course in reducing mathematics anxiety of pre-service elementary teachers. *School Science & Mathematics*, 98(3), 136–142. <https://doi.org/10.1111/j.1949-8594.1998.tb17406.x>
- Urbina, S. (2004). *Essentials of psychological testing*. New Jersey: John Wiley & Sons.
- Uşaklı, H. & Akpınar, E. (2015). Improving science laboratory anxiety scale (SLAS). *Kastamonu Education Journal*, 23(3), 1241–1250.
- Ünal, A. & Kılıç, M. S. (2016). Analysis of pre-service science teachers' anxiety situations towards laboratory. *The Western Anatolia Journal of Educational Sciences*, 7(14), 21–32.
- Wilson, B. (1996). Constructivist learning environments: Englewood cliffs. *Educational Technology Publications*.
- Wong, A. F. L., Young, D. J. & Fraser, B. J. (2006). A multilevel analysis of learning environments and student attitudes. *Educational Psychology: An International Journal of Experimental Educational Psychology*, 449-468. <https://doi.org/10.1080/0144341970170406>
- Wynstra, S. & Cummings, C. (1990, October). Science anxiety: Relation with gender, year in chemistry class, achievement and test anxiety. *Paper presented at the 12th Annual Meeting of the Midwestern Educational Research Association*, Chicago, IL.