

## Development of a Low-Cost Portable Two Row Pea Planter for the Hilly Terrain of Kashmir Valley

Muzamil Hamid WANİ<sup>1</sup>, Mohammad MUZAMIL<sup>2\*</sup>, Jagvir DIXIT<sup>3</sup>, Shahzad FAISAL<sup>4</sup>, Akhtar Ali KHAN<sup>5</sup>

### Abstract

The physical characteristics-size (3.12 – 8.98 mm), shape (1.13 – 1.33), test weight (194.66 – 209.66 g), sphericity (0.80 – 0.81) and engineering properties- bulk density (740.33 – 772.20 kg m<sup>-3</sup>), porosity (22.13 – 30.10 %), angle of repose (42.0 – 43.66°) of commonly grown pea varieties (Arkel, PB-89 and PB-1100) were measured at 8.5 – 9.5 % moisture content to select the design parameters of working components of two row pea planter. The moisture content of the pea varieties ranged from 8.5 – 9.5 per cent. The pea planter comprised of seed hopper, metering disc, handle, furrow opener, row marker and ground wheel. The pea planter was evaluated in terms of variety (Arkel, PB – 89, PB – 1100), metering disc (cup shaped flute metering disc and grooves on periphery metering disc) and depth of seed in the seed hopper (¾, ½ and ¼ full). The optimization of the parameters through response surface methodology (RSD) using design expert 13.0 revealed that operating the pea planter with cup shaped flute metering disc (M1), variety P3 (PB-1100) at ¾<sup>th</sup> depth of seed in the seed hopper resulted in average seeding spacing of 11.37 cm, missing index 3.45%, multiple index 12.46%, quality of feed index 84.08% and rate of work 0.04 hectare per hour. At optimum condition, the efficiency of the developed prototype of two row pea planter was found to be 82.0 percent. The economic analysis through bill of material revealed the cost of the machine as Rs. 1456, operating cost of 84.20 Rs h<sup>-1</sup>, benefit cost ratio of 1.30, break-even point of 0.02 ha and pay back period of 57.77 hours. The low-cost portable pea planter can serve as the panacea to pea sowing in the hilly terrain of Kashmir valley.

**Keywords:** Physicomechanical, Pea, Moisture content, Metering, Sowing, Kashmir

<sup>1</sup>Muzamil Hamid Wani, Division of Farm Machinery and Power Engineering, CoAE&T, SKUAST-K, Shalimar, J&K, India. Email: [muzamilwani.029@gmail.com](mailto:muzamilwani.029@gmail.com)

 OrcID: [0000-0002-9973-9897](https://orcid.org/0000-0002-9973-9897)

<sup>2\*</sup>Sorumlu Yazar/Corresponding Author: Mohammad Muzamil, Division of Farm Machinery and Power Engineering, CoAE&T, SKUAST-K, Shalimar, J&K, India. E-mail: [muzamil4951@gmail.com](mailto:muzamil4951@gmail.com)  OrcID: [0000-0002-1440-2604](https://orcid.org/0000-0002-1440-2604)

<sup>3</sup>Jagvir Dixit, Division of Farm Machinery and Power Engineering, CoAE&T, SKUAST-K, Shalimar, J&K, India. E-mail: [jagvirdixit@gmail.com](mailto:jagvirdixit@gmail.com)  OrcID: [0000-0002-4597-9959](https://orcid.org/0000-0002-4597-9959)

<sup>4</sup>Shahzad Faisal, Division of Processing and Food Engineering, CoAE&T, SKUAST-K, Shalimar, J&K, India. E-mail: [faisalpatna@gmail.com](mailto:faisalpatna@gmail.com)  OrcID: [0000-0001-8034-0563](https://orcid.org/0000-0001-8034-0563)

<sup>5</sup>Akhtar Ali Khan, Division of Entomology, SKUAST-K, Shalimar, India. E-mail: [akhtaralikhhan47@gmail.com](mailto:akhtaralikhhan47@gmail.com)  OrcID: [0000-0002-9984-1859](https://orcid.org/0000-0002-9984-1859)

**Atıf/Citation:** Wani, M. H., Muzamil, M., Dixit, J., Faisal, S., Khan, A. A. (2024). Development of a low-cost portable two row pea planter for the Hilly Terrain of Kashmir Valley. *Journal of Tekirdag Agricultural Faculty*, 21(3): 561-577.

©Bu çalışma Tekirdağ Namık Kemal Üniversitesi tarafından Creative Commons Lisansı (<https://creativecommons.org/licenses/by-nc/4.0/>) kapsamında yayımlanmıştır. Tekirdağ 2024

## 1. Introduction

Garden Pea (*Pisum sativum* L.) is an essential leguminous herbaceous winter vegetable crop grown on a commercial scale possessing socioeconomic, nutritional and health benefits (Falola et al., 2022). Globally, India is the second largest producer of pea, contributing 21 percent with a production of 5452 thousand metric tonnes from an area of 546 thousand hectares (Dhall, 2017). The major peas growing states are Uttar Pradesh, Madhya Pradesh, Bihar, Maharashtra and Punjab. Jammu and Kashmir produces 58080 metric tonnes from 2790 ha of land with a national share of one percent (Horticultural Statistics at a Glance, 2017). The potential of pea cultivation can be ascertained from the fact that one hundred farmers in Patalbagh village of Pulwama district earned fortunes by cultivating the garden pea as commercial crop on 17.7 hectares (350 kanals) of land and sold the produce worth Rs 1.20 crore in that particular year (Wani, 2020). Garden pea is enriched with nutrients essential to fulfil the daily nutrient requirement of the human body, possessing 22.5 % proteins, 62.1 % carbohydrates, 1.8 % fats, 64 mg per 100 g calcium, 4.8 mg per 100 g iron and high percentage of Vitamin A, B and C (Dhall, 2017). The inclusion of pea in the diet can help to cure the anomalies in per capita consumption of 175 grams per day (national average), which is lower than nutritional requirement of 285 grams per day and World Health Organization (WHO) recommended level of 400 grams per day (DOA, 2018).

However, the mechanization level of pea cultivation is abysmal. The initial basic unit operation of sowing/planting that defines the future perspective in terms of yield, growth and development of the plants is still carried out by conventional methods (Abd El-Lattief, 2014). The most common pea seed sowing practice of broadcasting is manifested with low seed placement, spacing inefficiencies (Alan and Ilbi, 2023) and serious back ache for the farmer which induces limitations to the area covered per day. In addition, it is difficult to maintain appropriate seed rate, evenness in inter – row and intra – row distribution of the seeds. The conventional method results in higher production cost, labour and time requirement, besides adversely impacting the crop stand and yield (Hore et al., 2017; Singh, 2014). In some areas, the method of dibbling is used for placement of seeds in holes or slits (Dhall, 2017). However, the cumbersome procedure of punching a hole and drilling a seed in the dibbled hole has compelled to shift towards mechanical single/multi crop planters. However, the power operated single and multicrop seeders/planters are mainly designed for plain areas with less adaptability in hilly areas owing to small land holdings, undulating topography, high cost (Singh and Vatsa, 2007) and lack of suitable power source (Singh et al., 2017).

Ergonomically, the planters imported from other areas are not suitable for the labourers localized in the hilly terrain of Jammu and Kashmir. The usage of such machines results in high drudgery, with high inclination to induce occupational health hazards that can prove detrimental to the health of agricultural labourers. It is, therefore, imperative that the design of the agricultural machinery must be location specific, ergonomically efficient and catering to the characteristics of the crop and labourers for efficient performance (Jouki and Khazaei, 2012). The involvement of appropriate mechanical interface can help to practice intensive agriculture and improve the production level from existing land and augmentation in input use efficiency of scarce farm resources (Shah et al., 2010). The engineering parameters has already been utilized at laboratory conditions (Mohammad, 2010) for seed metering device (Jadhav et al., 2020), planter design (Soyoye et al., 2018), harvesting machinery (Muzamil et al., 2016; Muzamil et al., 2021), agro-waste management machinery (Muzamil et al., 2013; Muzamil et al., 2015), willow wicker peeling machine (Malik et al., 2023), walnut grading (Rashid et al., 2023) and apple grading system (Muzamil et al., 2018b).

## 2. Materials and Methods

### 2.1. Market Share

The analysis with the help of surveyed data revealed that pea varieties - Arkel, PB-89 and PB-1100 occupies maximum share in the market. Accordingly, the varieties were procured from seed processing centre, Division of vegetable sciences, SKUAST – K, Shalimar, Srinagar, J&K, India. The physical characteristics and engineering properties of the pea seeds relevant to the design of the pea planter were measured using standard procedures (*Table 1*).

#### 2.1.1. Moisture content (percent)

A standard gravimetric procedure was used to assess the moisture content of the pea varieties (Arkel, PB-89, PB-1100). Three samples of pea seeds from each variety were weighed and placed in a hot air oven (Mohi ud din

et al., 2022). The temperature of the oven was maintained at 105° for 24 hours. The samples were placed in desiccator and samples were weighed again for the determination of moisture content (Sonboier et al., 2018).

$$\text{Moisture content} = \frac{W - W_0}{W} \quad (\text{Eq. 1})$$

Where, w = Weight of the seed sample before drying (g)

w<sub>0</sub> = Weight of oven dried seed sample (g)

## 2.2. Physical characteristics of pea seeds

### 2.2.1. Tri-axial dimensions/size

Three kilograms of pea seeds each of Arkel, PB-89, PB-1100 were used for the study. The tri-axial dimensions in terms of length (L), width (W) and thickness (T) of hundred randomly selected pea seeds were measured with the help of digital Vernier Calliper (Jadhav et al., 2020) possessing an accuracy of 0.01 mm, *Figure 1*.

### 2.2.2. Shape

The shape of the pea seeds was measured by the ratio of length (L) and width (W), also termed as eccentricity index (Kumar et al., 2017). The eccentricity index is interrelated with aspect ratio of pea seeds.

$$\text{Eccentricity index} = \text{Aspect ratio} = \frac{\text{Major axis}}{\text{Minor axis}} = \frac{\text{Length}}{\text{Width}} \quad (\text{Eq. 2})$$

### 2.2.3. Sphericity

Sphericity indicates the closeness to the sphere shape of equal volume. It is influenced by the estimation of geometric mean ratio (Jouki and Khazaei, 2012; Mohsenin, 1986).

$$\text{Sphericity} = \frac{\text{Geometric mean}}{\text{Length}} = \frac{(LWT)^{1/3}}{L} \quad (\text{Eq. 3})$$

### 2.2.4. Test Weight (gram)

Test weight serves as representative of hopper design as it determines the ability of the seed hopper to work for long hours without refilling. The test weight was determined randomly by selecting 1000 pea seeds of each pea variety and weighing on electronic weighing balance with accuracy of 0.001g. The intention was to design the seed hopper to accommodate pea seeds for at least 1 kanal (506.07 m<sup>2</sup>) of land for a single fill.

## 2.3. Engineering properties of pea seeds

### 2.3.1. Bulk density (kg m<sup>-3</sup>)

A sample of pea seeds from each variety was weighed on an electronic balance with an accuracy of 0.001 g. The weighed sample of pea varieties was placed in a graduated container of volume 500 ml. The bulk density was evaluated by the ratio of mass of the pea seeds to the volume occupied (Mohsenin, 1986).

$$\text{Bulk density} = \frac{\text{Bulk weight of pea seeds (kg)}}{\text{Volume of pea seeds (m}^3\text{)}} \quad (\text{Eq. 4})$$

### 2.3.2. True density (kg m<sup>-3</sup>)

The true density of pea seeds was determined by toluene displacement method (Sonboier et al., 2018). A sample of seeds from each of the three varieties was weighed on an electronic balance with an accuracy of 0.001g. The weighed seed sample was immersed in a container filled with toluene of known volume. The displacement in the volume of toluene due to filling of seed sample was measured and recorded giving the true volume of the pea seeds (without voids).

$$\text{True density} = \frac{\text{Mass of pea seeds (kg)}}{\text{Volume of liquid displaced (m}^3\text{)}} \quad (\text{Eq. 5})$$

### 2.3.3. Porosity (percent)

The porosity is the measure of unconsolidated mass of pea seeds. The measurement of the porosity of pea seeds was imperative to accommodate the voids in the design of seed hopper. Moreover, porosity is the function of bulk and true density (Mohsenin, 1986)

$$Porosity = \frac{True\ density - Bulk\ density}{True\ density} \times 100 \quad (Eq. 6)$$

### 2.3.4. Angle of repose (degree)

The angle of repose is related with the flowing ability in the seed hopper. The Angle of repose was determined by allowing the pea seeds (Arkel, PB-89, PB-1100) to form a regular heap by dropping the seeds over a smooth horizontal surface (Sonboier et al., 2018). The heap was left undisturbed, the height (h) and base (r) of the cone (heap) was measured, Figure 2.

$$Angle\ of\ repose, \phi = \tan^{-1} \left( \frac{h}{r} \right) \quad (Eq. 7)$$

## 2.4. Development of pea planter

The pea planter comprised of seed hopper, metering disc, handle, main frame, furrow opener, seed tube, ground wheel and covering device, Figure 3. The main frame was placed as the junction to accommodate all other components, Table 2. The main frame was attached with the handle to push the pea planter in the forward direction. The position and dimensions were decided ergonomically based on elbow height and maximum pushing position. The ergonomic parameters were used to include majority of the population involved in pea cultivation. The volume of the seed hopper was decided on the basis of weight of the seeds and bulk density. The number of flutes on the metering judges was calculated using diameter of the ground wheel (D), gear ratio (i) and recommended seed-seed spacing (x) for pea cultivation.

$$Volume\ of\ seeds, mm^3 = \frac{Weight\ of\ seeds\ to\ be\ filled, W_s}{Bulk\ density\ of\ seeds, \gamma_s} \quad (Eq. 8)$$

$$Number\ of\ flutes\ on\ the\ metering\ disc = \frac{\pi \times D}{i \times x} \quad (Eq. 9)$$

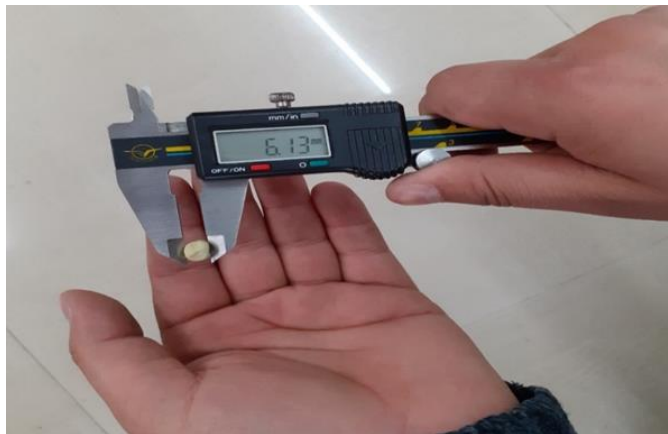

**Figure 1. Measurement of tri-axial dimensions of Arkel, PB – 89 and PB – 1100**

**Table 1. Engineering properties of Pea seeds relevant to the design of pea planter**

Property	Parameter	Instrument	Used for	Reference
	Moisture content	Hot air oven	Identification of material for better interaction between seed and material	(Jayan and Kumar, 2004; Sonboier et al., 2018)
Physical	Size	Vernier Calliper	Diameter of the seed picking flutes/cups of the metering mechanism	(Jadhav et al., 2020)
	Shape		Shape and depth of the seed picking flutes/cups	(Kumar et al., 2017)
	Sphericity		Picking of seeds from the seed hopper	(Mohsenin, 1986)
	Test Weight	Digital weighing balance	Shape and volumetric capacity of feeding hopper	(Jayan and Kumar, 2004)
Mechanical	Bulk density	Electronic balance	Design of seed hopper, seed tube and metering disc.	(Mohsenin, 1986)
	True density		Seed hopper capacity	(Sonboier et al., 2018)
	Porosity		Void space and capacity of seed hopper	(Mohsenin, 1986)
	Angle of repose		Slope of feed hopper for proper picking	(Jayan and Kumar, 2004; Sonboier et al., 2018)

**Table 2. Design values of individual components of the pea planter**

S. No.	Components	Parameters	Values	Design Value
1.	<b>Seed hopper</b>	Angle of repose (°) Weight (g) Bulk density (g mm <sup>-3</sup> )	41–43 1000 0.00075	Cuboidal – 152.4 × 139.7 × 76.2 mm Volume – 1622.3 cm <sup>3</sup>
2.	<b>Metering discs</b>	Size (mm) Sphericity Ground wheel diameter (mm) Seed spacing (mm)	(5.10 – 7.84) 0.80 – 0.81 355.0 120	Diameter – 152.4 mm No. flutes = 8 Flute diameter = 15 mm Flute depth = 15 mm
3.	<b>Furrow openers</b>	Soil type	Clay loam Stony or root infested soils	88.9 × 38.1 mm
4.	<b>Furrow closer</b>	–	–	400 × 300 mm
5.	<b>Ground wheels</b>	–	–	Diameter 355 mm
6.	<b>Handle</b>	Standing elbow height (mm) Elbow-Elbow breadth (mm) Internal grip diameter (mm)	949 – 1137 510 33	Height: 1150 – 1350 mm Width: 609.6 mm Diameter = 30 mm



Figure 2. Determination of angle of repose by heap of seeds method

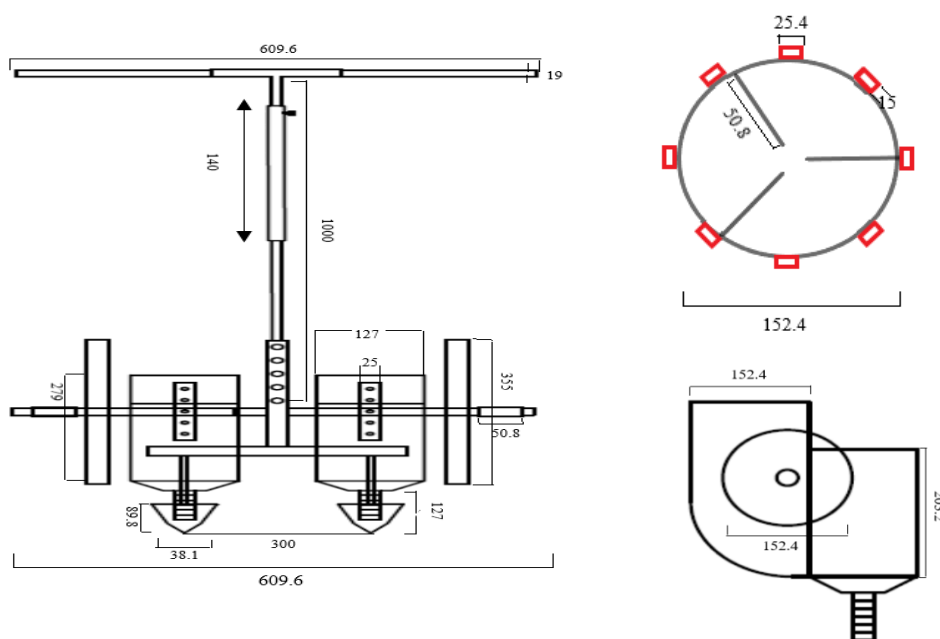

Figure 3. Isometric Dimensional overview of two row pea planter

### 2.5. Evaluation of developed pea planter

The performance of the developed prototype of pea planter was carried out as per plan of experiment in actual field conditions, *Table 3*. The pea planter was tested in terms of pea varieties (Arkel, PB-89 and PB-1100), metering mechanism (Metering disc with cup shaped flutes, Metering disc with grooves on the periphery) and depth of seed in the seed hopper ( $\frac{3}{4}$ <sup>th</sup>,  $\frac{1}{2}$ <sup>nd</sup> and  $\frac{1}{4}$ <sup>th</sup>). The responses were measured in terms of average seed spacing (cm), missing index (%), multiple index (%), quality of feed index (%), rate of work ( $\text{ha h}^{-1}$ ), field efficiency and mechanical damage to seeds (%). Each experimental trial was carried out on of 25 m<sup>2</sup> area. The force required to push the planter in forward direction was measured with help of spring dial gauge. The cost assessment was carried out in terms of operating cost, benefit-cost ratio, breakeven point and payback period.



**Table 3: Plan of experiment for evaluating the developed prototype**

Type	Parameters	Levels	Code	Responses	Reference
Performance Evaluation	Pea Varieties	3 (Arkel, PB-89 and PB-1100)	P1, P2 and P3	• Avg. Seed Spacing (cm)	(Malla et al., 2022)
	Metering Mechanism	2 (Metering disc with cup shaped flutes, Metering disc with grooves on the periphery)	M1 and M2	• Missing Index (%) • Multiple Index (%) • Quality of feed Index (%) • Rate of work (ha h <sup>-1</sup> ) • Field efficiency	
	Depth of Seed in the Seed Hopper	3 (¾ <sup>th</sup> , ½ <sup>nd</sup> and ¼ <sup>th</sup> )	D1, D2 and D3	• Mechanical Damage to seeds (%)	
Economic Assessment	•	• Cost of the pea planter • Operating cost of pea planter • Benefit-cost ratio • Breakeven point • Payback period			(Mohiuddin et al., 2022; Muzamil et al., 2018b)

## 2.6. Determination of performance parameters

### 2.6.1. Average seed spacing (cm)

The ability of the metering unit of the pea planter was measured in terms of average seed spacing with the help of measuring ruler, *Figure 6*. A total of 15 readings were recorded for each treatment combination.

### 2.6.2. Missing Index ( $I_{miss}$ ), Per cent

The missing index defines the empty slots that should have been occupied by the pea seeds. The metering unit of the pea planter was designed to collect the seeds from the seed hopper and deliver in the seed tube. The intention was to reduce the missing percentage of the seeds in the rows.

$$I_{miss} = \frac{n_1}{N} \quad (\text{Eq. 10})$$

Where,

$n_1$  = number of spacing >1.5 S

N = total number of measured spacing.

S = plant to plant spacing, cm

The recommended seed to seed spacing for pea crop is about 12 cm. A total of fifteen readings were measured for each treatment combination and spacing greater than 18 cm i.e. 1.5 x 12 cm were counted as missing index (Yasir et al., 2012).

### 2.6.3. Multiple Index ( $I_{mult}$ ), Per cent

Multiple index defines the multiple droppings of the seed at a particular spot, *Figure 6*. It was calculated as the percentage of spacings that are less than or equal to half of the set plant spacing of 12 cm.

$$I_{mult} = \frac{n_2}{N} \quad (\text{Eq. 11})$$

Where,

$n_2$  = number of spacing  $\leq 0.5$  S

S = plant to plant spacing, cm

It was calculated in the similar manner as that of missing percentage of pea seeds in a row. Fifteen readings were analysed and spacing less than or equal to 6 cm i.e. 0.5×18 cm was counted as multiple index (Yasir et al. 2012).

#### 2.6.4. Quality of feed index (QFI), Per cent

The quality of feed index refers to the percentage of spacing that is more than half i.e. 6 cm but not more than 1.5 times (18 cm of theoretical spacing of 12 cm). The quality of feed index is a function of both missing as well as multiple index (Yasir et al. 2012).

$$QFI = 100 - (I_{miss} + I_{mult}) \quad \text{(Eq. 12)}$$

#### 2.6.5. Rate of work (ha h<sup>-1</sup>)

The rate of work is the ratio of actual area covered (ha) in the field per hour (Bamgboye and Mofolasayo, 2006).

$$\text{Rate of work, ha h}^{-1} = \frac{\text{Area covered}}{\text{Actual time}} \quad \text{(Eq. 13)}$$

#### 2.6.6. Field efficiency (%)

The field efficiency relates the theoretical and actual field capacity of the pea planter. It was calculated by the ratio of the effective field capacity to the theoretical field capacity (Bamgboye and Mofolasayo, 2006).

$$\text{Field Efficiency } (\eta) = \frac{\text{Effective field capacity (ha h}^{-1}\text{)}}{\text{Theoretical field capacity (ha h}^{-1}\text{)}} \times 100 \quad \text{(Eq. 14)}$$

#### 2.6.7. Mechanical damage to seeds (%)

The metering unit was intended to pick up the seed from the seed hopper and deliver in the furrow. While passing through the metering unit, the seeds undergo mechanical damage. The mechanical damage to the pea seeds was carried out by visual inspection (Ani et al., 2016). The percentage of damage caused to pea seeds was calculated by the following formula:

$$\text{Damage percentage} = \frac{T_{nsb}}{T_{nsp}} \quad \text{(Eq. 15)}$$

Where, T<sub>nsb</sub> = total number of seeds broken

T<sub>nsp</sub> = total number of seeds planted

### 3. Results and Discussion

#### 3.1. Physical and engineering properties of pea seeds relevant to design of pea planter

The physical and mechanical parameters of pea seeds were used to decide the capacity of the seed hopper, size of flutes in the metering mechanism, flow ability of seeds from the seed hopper towards the metering unit, travel speed of the seeds through the seed tube and sticking ability of the seeds.

##### Physical properties:

**Moisture content (percent):** The moisture content determines the ability of the seeds to stick together. The mean moisture content (wet basis) of Arkel, PB-89 and PB-1100 was found to be 9.50 ± 0.5 %, 8.50 ± 0.5 % and 9.33 ± 0.57 %, respectively, Table 4. The angle of repose for Arkel, PB-89 and PB-1100 were found to be 42.00°, 43.66° and 41.66°, respectively. The values were close to 45-degree standard that causes the free flow of the materials from the inclined surface. The average angle of repose for different varieties was found to be 42.44° ± 0.71.

**Table 4: Moisture content of pea varieties**

Parameter	Arkel	PB-89	PB-1100
Moisture content	9.50 ± 0.50	8.50 ± 0.50	9.33 ± 0.57
Angle of repose	42.00 ± 1.00	43.66 ± 0.57	41.66 ± 0.57

**Tri – axial dimensions of Arkel, PB-89 and PB-1100:** The average length (mm), width (mm), thickness (mm) and shape of Arkel was found to be 7.84 ± 0.53, 6.21 ± 0.58, 5.42 ± 0.64 and 1.27 ± 0.11, Table 5. The sphericity



was found to be  $0.80 \pm 0.04$ . The results depicted that Arkel seeds are more or less spherical and cup type metering mechanism may help to collect the seeds from the seed hopper efficiently. In case of PB – 89, the average length (mm), width (mm), thickness (mm) and shape was found to be  $7.61 \pm 0.50$ ,  $6.02 \pm 0.48$ ,  $5.37 \pm 0.44$  and  $1.27 \pm 0.11$ . The seeds of PB – 89 were more spherical than Arkel and sphericity was found to be  $0.81 \pm 0.03$ . The closeness to the sphere hinted that a metering disc with cup shaped flutes can work to meter the seeds precisely. The seeds of PB – 1100 were similar to Arkel with sphericity of  $0.80 \pm 0.04$ . The average length (mm), width (mm), thickness (mm) and shape of PB-1100 was found to be  $7.41 \pm 0.51$ ,  $6.04 \pm 0.53$ ,  $5.10 \pm 0.56$  and  $1.23 \pm 0.11$ , respectively. The results were in consonance with average length, width and thickness as 8.50 – 10.20 mm, 6.50 – 8.50 mm and 4.00 – 5.10 mm at moisture content of 20 % and 5.37 - 6.24 mm, 4.97 - 5.67 mm, 4.06 - 4.60 mm at 63.5 % (Sonboier et al., 2018).

**Test Weight (gram):** The test weight is essential to decide the capacity of a seed hopper. The capacity of the seed hopper was decided in such a manner that at least 1 kanal (506.07 m<sup>2</sup>) of land was covered in one fill. The activity was expected to reduce the time lag in between the refilling of the seed hopper, which in turn, suffice the condition for enhancing the efficiency of the seed sowing operation. The mean test weight of Arkel, PB-89 and PB-1100 were found to be 209.66 g, 194.66 g and 203.66 g respectively, *Figure 4*.

**Engineering properties:**

**Bulk density, True density and Porosity:** The bulk density is essential to determine the mass of seeds occupied per unit of volume of seed hopper. The pore space is usually covered with factor of safety component. The mean bulk densities of Arkel, PB – 89 and PB – 1100 were found to be 772.20, 740.33 and 760.00 kg m<sup>-3</sup> respectively. The mean true density of Arkel, PB-89 and PB-1100 was found to be 991.66, 1058.66 and 993.00 kg m<sup>-3</sup>, respectively. The overall mean value of true density of selected three varieties was found to be 1014.44 kg m<sup>-3</sup> along with the standard deviation of 53.39, *Figure 4*. The porosity was intended to cover the pore space that would add additional space to the seed hopper. The mean value of porosity of Arkel, PB-89, PB-1100 were found to be 22.13, 30.10 and 23.46 %, respectively. The overall mean value of porosity for selected pea varieties was found to be 25.23 % along with the standard deviation of 4.31.

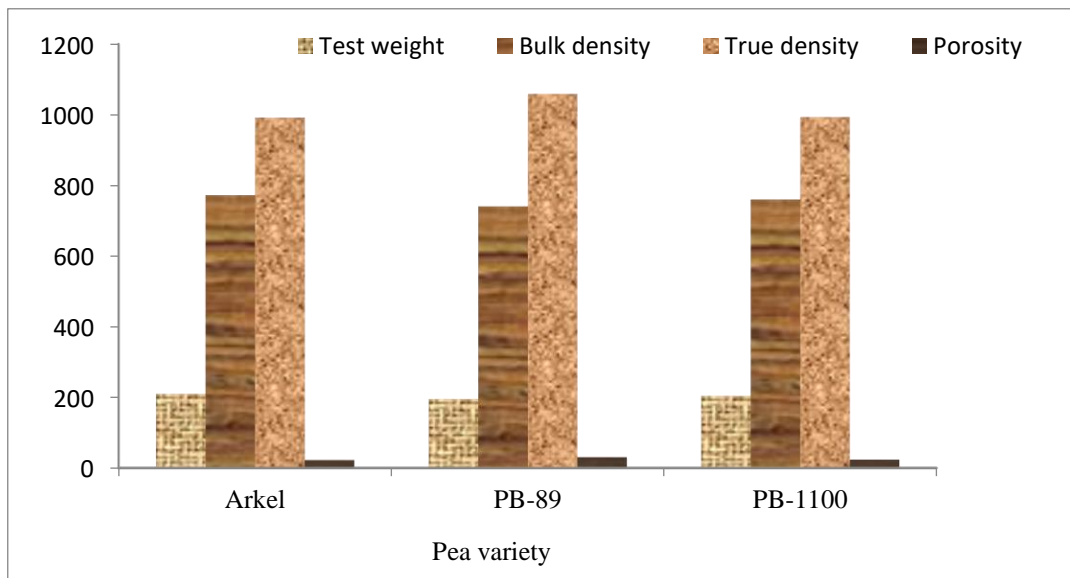

\*each value indicates mean of 3 replications

*Figure 4. Isometric Dimensional overview of two row pea planter*

**3.2. Two row Pea planter**

The pea planter comprised of main frame seed hopper, metering mechanism, handle, furrow opener, ground wheel and row marker, *Figure 5*. The design values were selected for each component on the basis of physical, engineering properties of pea seeds and mathematical calculations, *Table 2*. The seed hopper was made from 20 – gauge mild steel in rectangular shape with lower end rounded to ensure easy picking of seeds by the flutes/cups of

the metering discs. Accordingly, the dimensions of the seed hopper were fixed as 152.4 mm height, 139.7 mm breadth and height of 76.2 millimetre, to obtain the capacity of 1622.3 cm<sup>3</sup>, sufficient to cover an area of one kanal (506.07 m<sup>2</sup>) land area. The angle of repose was kept at 45°, slightly higher than angle of repose of pea seeds. The seed hopper was coupled with seed delivery system, comprising of a seed receiving cup, delivery funnel and seed tubes. The seed receiving cup and delivery funnel was made from 20 – gauge mild steel sheet and a low-cost PVC pipe was used for seed delivery tube. On each metering disc, eight flutes/cups were installed. The flutes were made from 8 mm round iron, which was cut into 8 flutes of 25.4 mm length. The flutes were 15 mm in diameter and depth to adjust at least two pea seeds, welded on the periphery of the iron disc in the parallel direction to ensure easy picking of seeds. Eight grooves were made on the periphery of the disc with each groove equidistant (60 mm) from each other.

The handle was provided to apply the push force and to steer the planter in the proper direction. The height of handle was decided based on the average standing elbow height 949 – 1137 mm for Kashmiri laborers (Dixit and Namgial., 2012; Muzamil et al., 2018a). The height was made adjustable to accommodate 200 mm more vertically with the help of nut and bolts to cover the differences in height of operators. The handle was made from 300 mm GI pipe based on internal grip diameter of 5<sup>th</sup> percentile of female workers and vertical adjustment was provided with GI pipe of 31 mm. The total extendable height of the handle was kept at 1150 – 1350 mm. The width of handle was decided on the basis of elbow – elbow breadth of 95<sup>th</sup> percentile of humans and was kept as 609.6 mm. The force required to move the planter in forward direction was 12 kgf. While operating the planter at the field, it was necessary to mark the area or provide a demarcating surface so as to avoid the repetition. The row marker was installed to maintain row – row spacing in the field. It was fabricated from 8 mm round iron of 1000 mm length and bent at 400 mm length. All the accessories were mounted on the main frame made from GI pipes, 25 mm and 20 mm diameter. The main frame was ‘I’ shaped to provide strength, reliability and distribute forces uniformly

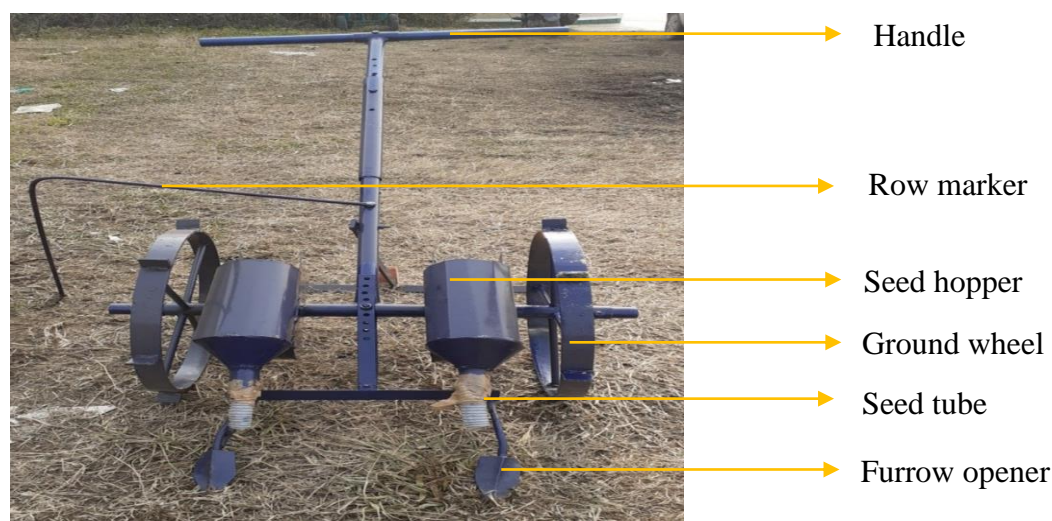

*Figure 5. Developed prototype of two row pea planter*



*Figure 6. Measurement of average seed spacing and multiple seed index*

Table 5: Tri-axial dimension of selected pea varieties relevant to the design of pea planter

Variety		Arkel					PB-89					PB-1100				
S. No.	Length	Width	Thickness	Shape	Sphericity	Length	Width	Thickness	Shape	Sphericity	Length	Width	Thickness	Shape	Sphericity	
1	8.38±0.44	6.61±0.52	5.41±0.67	1.28±0.12	0.78±0.03	7.66±0.34	6.05±0.56	5.37±0.46	1.28±0.11	0.80±0.01	7.93±0.62	6.25±0.61	5.05±0.44	1.27±0.10	0.78±0.04	
2	8.08±0.47	6.32±0.63	5.71±0.45	1.29±0.12	0.80±0.04	7.99±0.65	6.23±0.83	5.17±0.45	1.29±0.09	0.78±0.03	7.62±0.35	6.23±0.53	5.42±0.45	1.23±0.10	0.82±0.04	
3	7.97±0.41	6.58±0.59	4.99±0.67	1.22±0.10	0.79±0.05	7.70±0.37	5.97±0.32	5.41±0.44	1.29±0.09	0.80±0.03	7.51±0.62	6.03±0.51	5.09±0.63	1.25±0.10	0.80±0.04	
4	8.04±0.70	6.15±0.50	5.55±0.51	1.31±0.12	0.80±0.06	7.51±0.66	6.07±0.40	5.41±0.51	1.24±0.13	0.82±0.06	7.54±0.16	5.71±0.36	4.88±0.40	1.33±0.10	0.77±0.02	
5	7.78±0.46	6.06±0.52	5.51±0.51	1.29±0.08	0.80±0.03	7.58±0.34	6.28±0.41	5.33±0.34	1.21±0.11	0.82±0.04	7.22±0.32	6.13±0.40	4.91±0.43	1.18±0.10	0.82±0.05	
6	7.85±0.46	6.13±0.49	5.56±0.45	1.29±0.12	0.81±0.03	7.62±0.50	5.97±0.31	5.32±0.51	1.28±0.09	0.80±0.03	7.22±0.49	5.99±0.46	4.99±1.07	1.21±0.09	0.81±0.07	
7	7.76±0.49	6.50±0.67	5.50±0.61	1.20±0.11	0.82±0.04	7.60±0.56	6.03±0.35	5.47±0.49	1.27±0.14	0.82±0.03	7.24±0.61	5.83±0.48	4.93±0.34	1.25±0.09	0.80±0.04	
8	7.65±0.34	6.01±0.32	5.49±0.68	1.28±0.09	0.81±0.03	7.69±0.47	6.07±0.65	5.56±0.38	1.28±0.11	0.81±0.03	7.53±0.42	6.69±0.49	5.22±0.47	1.13±0.08	0.84±0.05	
9	7.32±0.40	6.13±0.45	5.32±1.02	1.20±0.12	0.83±0.07	7.44±0.51	5.66±0.28	5.17±0.34	1.32±0.13	0.80±0.06	7.28±0.44	5.89±0.38	5.19±0.53	1.24±0.11	0.82±0.06	
10	7.59±0.52	5.69±0.64	5.16±0.66	1.34±0.10	0.78±0.03	7.37±0.47	5.87±0.41	5.51±0.48	1.26±0.12	0.83±0.04	7.10±0.46	5.69±0.52	5.32±0.55	1.26±0.13	0.83±0.05	
<b>Avg.</b>	7.84±0.53	6.21±0.58	5.42±0.64	1.27±0.11	0.80±0.04	7.61±0.50	6.02±0.48	5.37±0.44	1.27±0.11	0.81±0.03	7.41±0.51	6.04±0.53	5.10±0.56	1.23±0.11	0.80±0.04	
<b>CV</b>	6.76	9.33	11.8	8.66	5.0	6.57	7.97	8.19	8.66	3.70	6.88	8.77	10.9	8.94	5.0	

\*Each value indicates mean of 3 replications

### **3.3. Evaluation of two row pea planter**

#### **3.3.1. Effect of Pea varieties, metering mechanism and depth of seeds in the seed hopper on average seed spacing (cm)**

Uniform seed to seed and row to row spacing is imperative to provide hassle free access to intercultural equipment's in order to reduce weed growth and ensure distribution of nutrients to the plants for higher yield (Kumar et al. 2018). The results revealed that average seed spacing increased with an increase in the depth of seeds in the seed hopper from D1 to D3 in both the metering discs M1 and M2. In case of cup shaped metering mechanism M1, the lowest average seed spacing of 11.24 cm was associated with treatment combination D1 P2 while maximum value of 24.43 cm with D3P3. In case of metering mechanism with grooves on the periphery M2, the minimum value of 13.13 cm occurred at D1P2 while maximum value of 29.42 cm was recorded at D3 P1, *Figure 7*. The reason can be attributed to the fact that collection of seeds from the seed hopper was much smoother with D1. As the depth of the seed in the seed hopper decreased to D3, the angle provided in the metering disc was not sufficient to pick the seeds. The metering disc with cup shaped flutes (M1) was able to pick up the seeds from the seed hopper better than metering disc with grooves on its periphery (M2) owing to its sweeping action (Swapnil et al., 2017). The statistical analysis revealed that the effect of pea varieties, metering mechanism and depth of seeds in the seed hopper was significant at 5 % level of significance. The interaction of metering mechanism and depth of seeds in the seed hopper was also found to be significant. The CD (critical difference) value for varieties was found to be 0.193 and that of interaction between metering mechanism and depth of seeds in the seed hopper was found to be 3.257.

#### **3.3.2. Variation in missing index (%)**

The missing index is an indicator of number of seeds missed per drop. The results revealed that missing index increased with increase in the depth of seeds in the seed hopper from D1 to D3. For metering mechanism M1, the minimum mean value for missing index was 2.22 % with P3 pea variety at D1 While the maximum mean value was 62.22% with P1 pea variety at D3 depth of seeds in the seed hopper. In case of Metering mechanism M2, the lowest value for missing index was 11.10 % for P1 and D1 while the highest value 80.00 % was for P3 and D3, *Figure 8*. The main reason was the inability of the metering discs to collect the seeds at lower depth. The picking efficiency of the metering disc M1 was better than metering mechanism M2 owing to the shape of flutes slanting outward from the outer periphery. The missing percentage was lower than 13.43 % (Rabbani et al., 2016) and 20% (Yasir et al., 2012). The statistical analysis revealed that there was a significant effect of metering mechanism and depth of seeds in the seed hopper on missing index at 5% level of significance. The CD value for metering mechanism was found to be 2.683 and that of depth of seeds in the seed hopper was found to be 8.035.

#### **3.3.3. Change in multiple index (%)**

The multiple index shows the clustering of seeds per drop. The results revealed that multiple index decreased with decrease in the depth of seeds in the seed hopper. In case of Metering disc with cup shaped flutes, the minimum value for multiple index was found to be 2.22 % for P3 and D3 While maximum value was found to be 13.33 % for all pea varieties and at D1, *Figure 9*. For metering disc with grooves on periphery, the lowest value (0.00%) was observed for all the three varieties and at D3 while the highest value (13.33%) was observed for P1, P2 and at D1. The metering mechanism M1 showed more multiple seeds per drop than M2 owing to its better shape of flutes for picking up multiple seeds at time. The statistical analysis revealed that there was a significant effect of metering mechanism and depth of seeds in the seed hopper on missing index at 5% level of significance. The CD value for metering mechanism was found to be 1.834 and that of depth of seeds in the seed hopper was found to be 4.119. The comparative analysis of metering discs with respect to performance indices (missing index and multiple index) revealed that cup shaped flute metering disc (M1) resulted in lower missing percentage in comparison to grooves on periphery metering disc (M2), respectively. The missing percentage jumped from 5.18 to 12.6 at D1 depth of the seed in the seed hopper as the metering disc was changed from M1 to M2. A similar trend was observed with D2 and D3. The multiple index at D1 was found to be numerically similar for both metering discs. However, as the depth was reduced to D2, the multiple percentage showed a significant drop from 9.62 to 3.7, signifying that M2 was able to pick the seeds better than M1. A similar pattern was observed at D3.



### 3.3.4. Influence of independent parameters on quality of feed index (%)

The quality of feed index shows the closeness of the seeds delivered from the seed hopper to the furrow in relation to the recommended seed spacing. It is a function of both missing as well as multiple indices. The quality of feed index decreased with decrease in the depth of seeds in the seed hopper, *Figure 10*. The lowest value for quality of feed index (20.00 %) was observed for P3 pea variety, M2 and D3 while the highest mean value for quality of feed index was 84.45% for P3 pea variety, M1 and D3, *Fig. 10*. The results revealed that more depth of seeds in the seed hopper resulted in higher quality of feed index. The statistical analysis revealed that there was a significant effect of interaction between metering mechanism and depth of seeds in the seed hopper at 5% level of significance. The CD value for interaction between metering mechanism and depth of seeds in the seed hopper was found to be 1.33. The quality of feed index was within 74.75-94.04% range of pneumatic precision seed metering mechanism (Yasir et al., 2012).

### 3.3.5. Rate of work and Field efficiency

The rate of work indicates the area covered in the field per unit time. The results from the field experiments revealed that the time taken to sow/plant the experimental plot of 25 m<sup>2</sup> was 180 seconds. The rate of work or the effective field capacity was found to be 0.05 hectare per hour. However, when the pea planter was operated on moist soil, the rate of work decreased to 0.04 ha h<sup>-1</sup> ostensible due to more time to complete the experimental unit. The rate of work for single row maize planter was 0.04 ha h<sup>-1</sup> (Ikechukwu et al. 2014), 0.12 ha h<sup>-1</sup> push type maize planter (Rabbani et al., 2016) and 0.27 ha h<sup>-1</sup> vertical plate maize seed planter (Ani et al., 2016). Field efficiency is a function of the rate of work. It was observed that minimum mean value for field efficiency was 66.67 %, when the planter was operated on moist soil and maximum value as 83.33 % at dry field conditions, respectively.

### 3.3.6. Mechanical damage to seeds (%)

The mechanical damage to seeds indicates an injury to the seed surface while metering the seeds or delivering the seeds in the furrow. The mechanical damage of the seeds was found to be associated with metering mechanism and not directly related with other parameters. In case of metering mechanism M1, the visible mechanical damage to seeds was negligible. However, in case of M2, a mechanical damage of 2.63 % was observed at  $\frac{3}{4}$  depth of seeds in the seed hopper for all the three varieties. A mechanical damage of 1.71 % in vertical plate seed planter (Oduma et al., 2014) and 9.7, 7.5 and 3.4 % for gingelly, kuakkan and maneri (Alwis, 2004) provided a logical comparison with the 2.63 % mechanical damage in pea planter.

### 3.4. Optimization of operational parameters

The numerical optimization of variables was carried out by using Design expert 13.0 version. The main objective was to ensure uniform seed and row spacing, minimize missing index, multiple index and mechanical damage to seeds, maximize quality of feed index, rate of work and field efficiency, *Table 6*. The analysis of the response parameters revealed that operating the pea planter with PB – 1100 (P3) variety at  $\frac{3}{4}$ th depth of seeds in the seed hopper (D1) and cup shaped metering disc (M1) resulted in average seed spacing of 11.37 cm, missing index of 3.45 %, multiple index of 12.46%, quality of feed index of 84.08 %, rate of work 0.04 ha h<sup>-1</sup> and 82.09 % field efficiency, *Table 6*. The overall desirability was 0.82.

### 3.5 Cost assessment

The cost analysis was carried out in terms of operating cost, benefit-cost ratio, breakeven point and payback period. The bill of material revealed that cost of the two-row pea planter was Rs. 1456 with operating cost of Rs. 84.2 per hour, *Table 6*. The benefit-cost ratio was calculated as 1.30:1, showing a tilt towards profitability and sustainability. The breakeven point and payback period was recorded as 0.02 ha and 57.77 hours, respectively.

**Table 6. Optimization of operational parameters of two row pea planter**

Variety: P3 Metering mechanism: M1 Depth of seed: D1	Avg. seed spacing, mm	Missing Index	Multiple Index	QFI, %	Rate of work, ha h <sup>-1</sup>	Field efficiency
	11.37	3.45	12.46	84.08	0.04	82.09
	Desirability					0.82
Cost of two row pea planter, Rs	Operating cost, Rs h <sup>-1</sup>	Benefit-cost ratio	Breakeven point, ha	Payback period, hour		
1456	84.2	1.30:1	0.02	57.77		

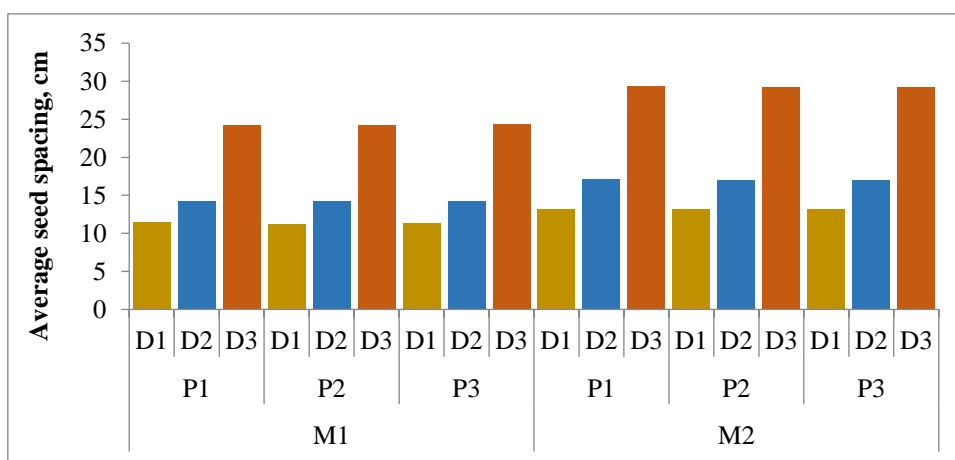

**Figure 7. Variation in average seed spacing with depth of seed in seed hopper and pea variety**

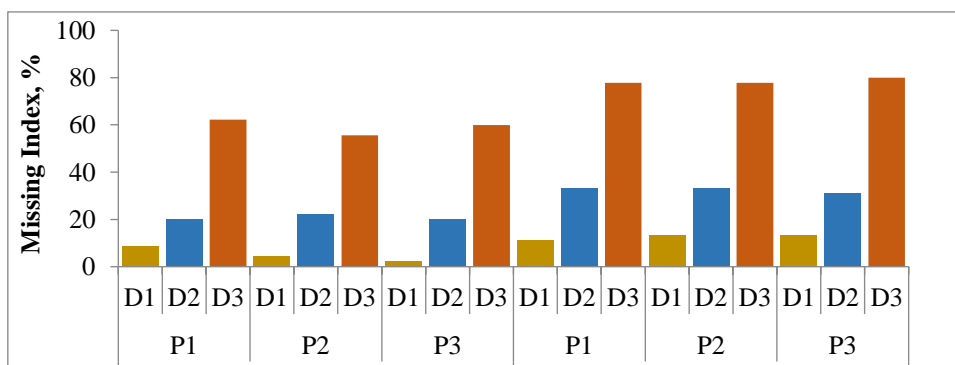

**Figure 8. Change in missing index with independent parameters**

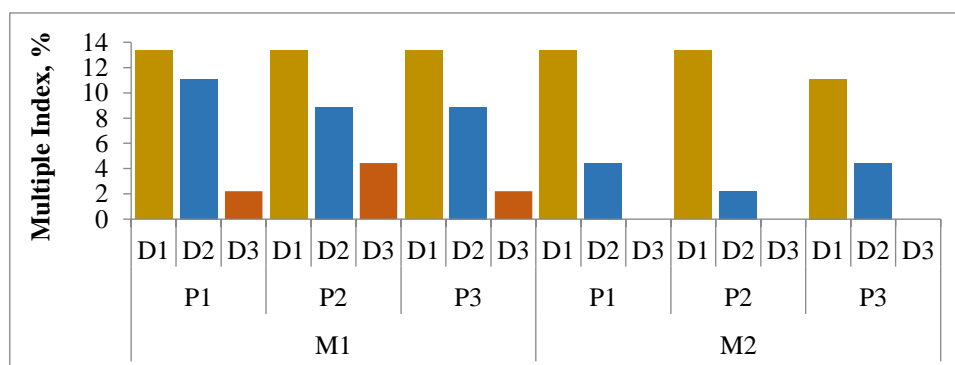

**Figure 9. Variation in multiple index with depth of seed in seed hopper and pea variety**

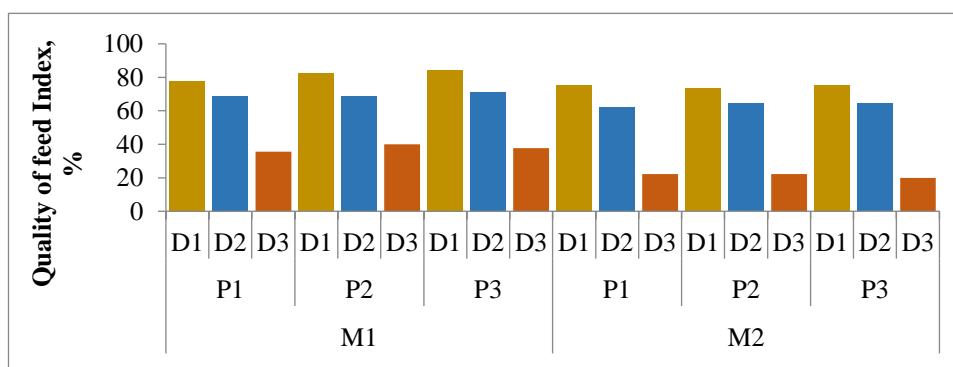

Figure 10. Variation in quality of feed index with independent parameters

#### 4. Conclusions

The physical and engineering properties were exploited to design and develop a two-row pea planter for pea varieties commonly grown in the state of Jammu and Kashmir. The ergonomical parameters of elbow – elbow breadth (510 mm), standing elbow height (949 – 1137 mm) and internal grip diameter (33 mm) were utilized to design the handle in order to accommodate majority of the population. The pea planter comprised of seed hopper, metering disc, handle, furrow opener, row marker and ground wheel. The optimization of the results through Design expert 10.0.1 revealed that operating the machine with cup shaped flute metering disc (M1) with variety P3 (PB – 1100) at  $\frac{3}{4}$ th depth of seeds in the seed hopper resulted in average seeding spacing of 11.37cm, missing index 3.45 %, multiple index 12.46 %, quality of feed index 84.08 %, rate of work 0.04 ha h<sup>-1</sup>. The efficiency of the developed prototype at optimum conditions was found to be 82.0 percent. The draft required to push the pea planter in the forward direction was found to be 12 kgf. The Benefit-cost ratio, Break-even point and Payback period of two row pea planter was calculated as 1.30, 0.02 ha and 57.77 hours. The pea planter can be used for small fields and undulating topographical conditions.

#### Acknowledgment

The authors would like to acknowledge the help rendered by the scientific and technical staff of Division of Farm Machinery and Power Engineering, College of Agricultural Engineering and Technology, SKUAST-K that resulted in the completion of the study within stipulated time.

#### Ethical Statement

The study does not require to seek permission from the ethics committee

#### Conflict of Interest

The authors declare no conflict of interest exists at any phase.

#### Authorship Contribution Statement

Concept: Wani, M. H., Muzamil, M.; Design: Muzamil, M., Wani, M. H.; Data Collection or Processing: Wani, M. H., Muzamil, M.; Statistical Analysis: Wani, M. H., Faisal, S.; Literature Search: Dixit, J., Wani, M. H., Khan, A. A.; Writing, Review and Editing: Wani, M. H., Muzamil



---

**References**

- Abd El – Lattief, E. A. (2014). Bread wheat (*Triticum aestivum* L.) Productivity and profitability as affected by method of sowing and seeding rate under Qena environment. *Asian Journal of Crop Science*, 3(4):188–196.
- Alan, O. and Ilbi, H. (2023). Effect of cutting treatment on seed yield and seed quality of dill. *Journal of Tekirdag Agricultural Faculty*, 20(1): 94-103. <https://doi.org/10.33462/jotaf.1073356>
- Alwis, P. L. A. G. (2004). Design and Development of a Row Seeder For Gigelly, Kurakkan and Meneri. Proceeding of the Second academic Sessions. Department of Agricultural Engineering, Faculty of Agriculture, University of Ruhuna, Kamburupitiya, Sri Lanka.
- Ani, O. A., Uzoejinwa, B. B. and Anochili, N. F. (2016). Design, construction and evaluation of a vertical plate maize seed planter for gardens and small holder farmers. *Nigerian Journal of Technology*, 35(3):647–655.
- Bamgboye, I. A. and Mofolasayo, S. A. (2006). Performance evaluation of two row okra planter. *Agricultural Engineering International: CIGR e-Journal*, 8(7). Manuscript PM 06002.
- Dhall, R. K. (2017). Pea cultivation. A Publication by center For Communication And International Linkages. Punjab Agricultural University, Ludhiana.
- Dixit, J. and Namgial, D. (2012). Anthropometry of farm workers of Kashmir region of India for equipment design. *Journal of Agricultural Engineering*, 49(2): 8–15.
- DOA. (2018). Vegetable Production in Kashmir – A holistic review. Directorate of Agriculture, Kashmir, Government of Jammu and Kashmir.
- Falola, A., Mukaila, R., Lawal, T. F. and Akinsuyi, M. A. (2022). Commercialization of pigeon pea production: its determinants and constraints. *Journal of Tekirdag Agricultural Faculty*, 19(4):840-849.
- Hore, P., Gupta, G., Deshmukh, S., Dhawale, A. and Patil, S. (2017). Modern seed sowing techniques and developing technologies. *International Journal of Innovative and Emerging Research in Engineering*, 4(3): 69–72.
- Horticultural Statistics at a Glance. (2017). A report by Horticulture Statistics Division, Department of Agriculture, Cooperation & Farmers Welfare, Ministry of Agriculture & Farmers, Welfare, Government of India.
- Ikechukwu, A., Ibukun, B. and Ikechukwu, C. U. (2014). Design and Fabrication of a single row maize planter for garden use. *Journal of Advancement in Engineering Technology*, 1(2): 2348–2931.
- Jadhav, M. L., Din, M., Nandede, B. M. and Kumar, M. (2020). Engineering properties of paddy and wheat seeds in context to design of pneumatic metering devices. *Journal of the Institution of Engineers (India): Series A*, 101: 281-292. <https://doi.org/10.1007/s40030-019-00430-7>
- Jayan, P. R. and Kumar, V. J. F. (2004). Planter design in relation to the physical properties of seeds. *Journal of Tropical Agriculture*, 42(1):69–71.
- Jouki, M. and Khazaei, N. (2012). Some physical properties of rice seed. *Research Journal of Applied Science, Engineering and Technology* 4(13): 1846-1849.
- Kumar, A. B., Rao, P. V. K. J. and Edokondalu, L. (2017). Physical properties of maize. *International Journal of Agricultural Sciences*, 9(27):0975 –3710.
- Kumar, V., Rani, V., Jain, M. and Kumar, A. (2018). Parameter Optimization of ‘Anjul’ seed metering mechanism for okra seeds. *International Journal of Current Microbiology and Applied Sciences*, 7(3):1544 – 1550.
- Malik, M. A., Faisal, S., Muzamil, M., Langoo, B. A., Shukla, R. M., Reshi, M., Dhekale, B. and Hussain, S. Z. (2023) A low-cost portable willow wicker peeling machine: An innovative mechanical intervention in the Wickercraft Industry of Kashmir. *Journal of the Institution of Engineers (India): Series A* 104: 271–280. <https://doi.org/10.1007/s40030-023-00726-9>
- Malla, U. M., Khan, A. R., Muzamil, M., Mohiuddin, M., Rashid, S., Banday, R. Z. and Kumar, R. (2022). Development and evaluation of four-row seeder for vegetable crops in the temperate region of Jammu and Kashmir. *SKUAST Journal Research*, 24(1):71-79. <https://doi.org/10.5958/2349-297X.2022.00016.2>
- Mohammad, R. S. (2010). The moisture content effect on some physical and mechanical properties of corn. *Journal of Agricultural Science*, 2(4): 125-134.
- Mohiuddin, M., Muzamil, M., Dixit, J., Faisal, S. and Khan, I. (2022). Engineering Properties of Chilli Fruit Relevant to the Design and Evaluation of Chilli Seed Extractor for Hilly Region of Kashmir Valley. *Journal of Institution of Engineers, India Ser. A*, 103: 433-443. <https://doi.org/10.1007/s40030-022-00617-5>
- Mohsenin, N. N. (1986). Physical Properties of Plant and Animal Materials, 2nd ed. Gordon and Breach Sc. Publishers.
- Muzamil, M., Dixit, J., Khan, J. N. and Nirbhavane, S. (2018a). Practical Manual on Ergonomics. SKUAST-K, Press.
- Muzamil, M., Mani, I., De, D. and Lande S. (2013). Influence of operational parameters of windrow turner for mass production of compost. *International Journal of Agricultural and Statistical Science*, 9(1): 19-28.
- Muzamil, M., Mani, I., Kumar, A. and Lande, S. (2016). Influence of moisture content, loading rate and internode position on the mechanical properties of paddy and wheat straw. *International Journal of Bio-resource and Stress Management*, 7(2): 280-285.
-

- Muzamil, M., Mani, I., Kumar, A. and Shukla, L. (2021). An engineering intervention to prevent paddy straw burning through insitu microbial degradation. *Journal of the Institution of Engineers (India): Series A*, 102: 11-17. <https://doi.org/10.1007/s40030-020-00490-0>
- Muzamil, M., Mani, I., Kumar, A., Shukla, L., Lande, S. and Saxena, A. K. (2015). Optimization of straw size, dose of compost inoculant along with engineering and microbial parameters for paddy straw degradation in shortest possible time. *Journal of pure and applied Microbiology*, 9(2): 453-461.
- Muzamil, M., Wani, J., Mustafa, A., Mohiuddin, M., Mir, Aayat., Faisal, S. and Nirbhavane, S. (2018b). A low-cost divergent type apple grader for Kashmiri apples. *International Journal of Current Microbiology and Applied Sciences*, 7(4): 3561-3569.
- Oduma, O., Ede, J. C. and Igwe, J. E. (2014). Development and performance evaluation of a manually operated cowpea precision planter. *International Journal of Engineering and Technology*, 4(12): 693 – 699.
- Rabbani, M. A., Hossain, M. M., Asha, J. F. and Khan, N. A. (2016). Design and development of a low cost planter for maize establishment. *Journal of Science, Technology and Environment Informatics*, 4(1): 270–279.
- Rashid, Z., Faisal, S., Muzamil, M., Dixit, J., Shukla, R. M. and Khan, I. (2023). Development of an innovative universal walnut cracking and separating machine for farmers and walnut industry of Kashmir Valley. *Journal of the Institution of Engineers (India): Series A*, 104:355–365. <https://doi.org/10.1007/s40030-023-00718-9>
- Shah, A. A., Showkat, M., Rather, S. A., Hussain, T. and Thaploo, R. (2010). Productivity analysis of crops grown under different farming systems of Kashmir. *International Journal of Agricultural Sciences*, 6(2): 592–594.
- Singh, S. (2014). Farm mechanization in hills of Uttarakhand, India – A review. *Agriculture for Sustainable Development*, 2(1):65–70.
- Singh, S. and Vatsa, D. K. (2007). Development and evaluation of a light weight power tiller operated seed drill for hilly region. *Ama, Agricultural Mechanization in Asia, Africa & Latin America*, 38(3): 45–50.
- Singh, S., Sahoo, D. C. and Bisht, J. K. (2017). Development and performance evaluation of manual/bullock operated multicrop planter for hilly region. *Agricultural Engineering International: CIGR Journal*, 19(1): 81–86.
- Sonboier, K. K., Mahilang, K. K. S., Minj, P., Porte, P. and Taran, T. (2018). Some Physical properties of Green pea. *International Journal of Pure and Applied Bioscience*, 6(1): 573–579.
- Soyoye, B. O., Ademosun, O. C. and Agbetoye, L. A. S. (2018). Determination of some physical and mechanical properties of soyabean and maize in relation to planter design. *Agricultural Engineering International: CIGR Journal*, 20 (1):81–89.
- Swapnil, T. V., Kasturi, M. L., Girish, P. V. and Rajkumar, P. N. (2017). Design and fabrication of seed sowing machine. *International Research journal of Engineering*, 4(9):2395–0072.
- Wani, M. (2020). Development and performance evaluation of two row planter at field conditions. Unpublished M.Tech. Thesis. SKUAST-K, Shalimar, J&K, India.
- Yasir, S. H., Liao, Q., Yu, J. and He, D. (2012). Design and test of a pneumatic precision metering device for wheat. *Agricultural Engineering International: CIGR Journal*, 14(1):16–25.