





A Modeling Approach for Designing New Acoustic Materials

Hatice Mehtap BULUKLU^{1,*} , Ercan KOSE² , Filiz BAL KOCYIGIT³ 

¹Tarsus University, Graduate Education Institute, Production Engineering ABD, Tarsus/Mersin, Türkiye

²Tarsus University, Faculty of Engineering, Electrical-Electronics Engineering Department, Tarsus/Mersin, Türkiye

³Atılım University, Faculty of Fine Art Design and Architecture, Department of Architecture, Ankara, Türkiye

Highlights

- Behavior of low-pass filter acoustic materials with natural content, capable of providing STL.
- Obtaining mathematical models of acoustic samples with recyclable materials from nature.
- Comparative analyzes of samples for which mathematical models were created for filter design.
- Filter design of acoustic materials that provides significant gains in the transition model.
- Acoustic materials based on natural products without carbon emissions.

Article Info

Received: 16 June 2023

Accepted: 22 Nov 2023

Keywords

Acoustic material
Active low-pass filter
Mathematical modeling
Sound Transmission Loss
Functional simulation

Abstract

In this study, mathematical modeling design based on Sound Transmission Loss measurement results of new acoustic material samples with natural content was carried out. Using the test samples in question, transfer function of acoustic materials based on electronic filter circuit design and a transition design method for the production of new acoustic materials by utilizing the transfer function is presented. Based on the experimental results of the test samples, it is the most suitable low-pass filter structure for the proposed design. In this study, active Sallen-Key low-pass filter structure is preferred and used. Sound Transmission Losses in dB (decibels) of acoustic samples were obtained experimentally for 500, 1000, 2000 and 4000 Hz. fundamental frequencies in the literature. Based on these data, transfer function simulation suppression gain results were obtained in TINA-TI program, active filter circuit designed, and MATLAB program. When the other results were compared in the experimental results, it was seen that very close values were obtained. It has been demonstrated that the proposed method can be used effectively in the design and examination of new acoustic materials.

1. INTRODUCTION

Today, noise can be encountered depending on the levels of sounds created by vehicles, factories and industrial processes. In case of increase and continuity of noise level, decrease in motivation, hearing impairment, cardiovascular, mental health, etc. health problems such as The World Health Organization (WHO) defined health as a mental and physical condition in 2009 and stated that environmental noise poses a negative threat to public health. In 1999, it published guidelines according to harmful noise levels due to noise in various environments [1]. Acoustic insulation materials have an important place in order to reduce/prevent noise in various environments [2]. Different methods, natural and chemical-containing synthetic fibers or materials with some porous structure are preferred in terms of acoustics based on noise reduction [3]. In this direction, in a study on generator noise, it was stated that active and passive methods can be applied in order to reduce the noise during the operation of generators. In passive methods, rock wool, rubber, acoustic foam, acoustic sponge etc. It is seen that synthetic materials are used [4]. In other study on synthetic materials, it was stated that building materials such as polyurethane, polystyrene, glass wool and rock wool are mostly used as filling materials and that they cause an increased risk of fire because they are petroleum-derived materials [5].

Mathematical models can be used to examine materials in more detail structurally. Mathematical modeling is defined as the process of revealing the patterns within these events and phenomena by trying to express

*Corresponding author, e-mail: hmehtap@yahoo.com

mathematically or mathematically an event, phenomenon and the relationships between events [6]. Mathematical modeling, which can be applied in many areas, can also be used in acoustics. In this direction, in a study, with Comet Trim program, the elastic foam materials currently used in the automotive were modeled and examined in the 1/3 octave band in the frequency range of 125-4000 Hz. When the results obtained with Comet Trim program were compared with the test values, it was observed that the sound absorption coefficient and Sound Transmission Loss estimates made by the program were similar to the real values [7]. In another study on modeling in porous materials, the theory based on the acoustic transfer matrix method and the mobility matrix model was preferred. When the proposed model of melamine foam and porous aluminum was applied, it was seen that there was a good agreement between the experimental and numerical data [8]. In addition, a different study was carried out in Mimar Kemaleddin Hall in order to evaluate the acoustic performance, and acoustic analyzes were carried out with the ECOTECT v.5.20 computer simulation program. In order to improve the acoustic performance, reflective and absorber panels were added to the current situation of the hall and 7 different models were compared, and suggestions were developed depending on the frequency of the use of the hall for music and speech purposes [9].

On the other hand, materials containing natural materials with natural acoustic properties are less frequently encountered in the literature and industry. In order to reduce the risks that may be caused by synthetic materials, to reduce carbon emissions and to increase indoor air quality, low-cost, easily accessible and recyclable materials that can be found in large quantities in nature and have acoustic properties have gained importance in this study. The data of this study were obtained by testing samples prepared with natural materials in a single layer and composite structure in the Alpha Cabin model system, which was proposed and designed in the previous study [10]. It can show similar features such as reducing (suppressing) the noises at some frequencies during the test processes of the samples, reducing the input signals to the filters by a certain amount and taking them as output signals. Due to the similarity in question, it has been predicted that natural-containing samples may be important in filter designs, therefore, by making calculations according to the suppression gain (in dB) values of the tested samples, suitable filter designs that are thought to be important in the acoustic field can be made. Technological developments in computer software and hardware have enabled the filter designs to be analyzed more easily.

Systems that can reshape and transform the spectrum of a signal are known as digital filters [11] and are one of the basic elements of the signal and are used in many electronic devices [12]. It is possible to see different expressions of the filter in the literature. When evaluated depending on the frequency, it is defined as a circuit designed to pass a certain frequency band and attenuate all signals outside this band [13]. Filters can also be separated according to their circuit structures and functions. In electronics; passive or active, analog or digital, used like high pass, low pass, band pass, band stop, all pass, linear or non-linear, IIR, FIR etc. There are many types of filters [14]. The elements it contains may also vary according to the circuit structures. For example, in the passive filter circuit, there are resistors, inductors and capacitors, and in the active filters, there are operational amplifiers (op-amps) and resistors and transistors [13]. In addition, it is seen that they are classified according to their active or passive structures and frequencies. In this sense, active filters are divided into low-pass (low-pass), high-pass (high-pass), band-pass (band-pass), band-stop (band -stop) filters according to certain frequencies [15]. These filters are used in many different areas. For example, with the increase of wireless technology, radio, mobile phone, etc. in applications, universal filters are designed to eliminate unwanted signals [16]. Many methods are used in the design. One of the most used is the Sallen-Key topology introduced by R.P. Sallen and E.L. Key, which is known to have low impedance characteristics. This topology also has different active filter types such as Bessel, Butterworth, Chebyshev and Elliptic [17]. In addition, filters are used in signal processing [18- 21], in improving electrical power quality by suppressing harmonics at high voltages [22- 24], in high-frequency microstrip antenna design [25], in separating very small signals from noise in the biomedical field [26] it can be used in many fields such as.

In this study, it has been tried to establish a relationship between the aforementioned filters and acoustic materials. The fundamental data of the relationship depends on the sample preparation based on the material selection and design. In the study, samples were prepared by placing recyclable materials (cones and walnut shells), which can be easily obtained from nature, on gypsum board with plaster. Among the samples, composite structures were obtained by using natural materials such as 100% natural wool felt and heraclite

and tested in the Alpha Cabin model system [10]. The Sound Transmission Loss values, which are the measurement results, were evaluated and taken as the suppression gain. Since it is known that filters can be effective in reducing unwanted sounds in different environments, it is foreseen that the samples prepared and tested can be considered as a filter. In this direction; as a result of the calculations made with special programs such as TINA-TI and MATLAB and the comparative analysis and interpretation of the values, it has been determined that a low-pass filter topology can be designed.

The contribution of this study to the literature on the realization of the mathematical models of acoustic materials based on natural products, based on active electronic filter circuit designs, is given below.

- I. Acoustic materials based on natural products provide Sound Transmission Loss, and behavioral representations such as low-pass filters have been demonstrated.
- II. A mathematical model of acoustic materials produced with natural products has been obtained.
- III. Mathematical models provided an environment that could enable easier analysis of acoustic samples.
- IV. It has been presented to the literature that the transition model based on filter design can provide significant gains for the design of new acoustic materials.

This study consists of three parts. There are literature review in the first part, material and method sections in the second part. In the material section, there are tables and graphics related to the Sound Transmission Loss values [10] obtained as a result of the experimental studies carried out in the designed and developed test box. In the method section; In this study, equations used in circuit design, programs and functions are given. In the third part; the Sound Transmission Loss values were taken as the suppression gain and an electronic filter circuit was tried to be designed. There are tables and graphs, comparative analysis and comments about the approximate calculated values during the design phases. In the fourth part, the results and recommendations are given, and in the fifth part, the findings and discussions.

2. MATERIALS AND METHODS









It is inevitable that we encounter noise in the flow of daily life. Noise can affect people with many factors such as work motivation, work accidents, productivity and health problems. Sound Transmission Loss is seen as an important parameter in reducing/preventing these problems and suppressing unwanted sounds (noises) encountered in different environments. Bal Koçyigit [27], defined “Sound Transmission Loss as the logarithmic ratio of the energy incident on a material to the energy transferred to the opposite side”. According to Buluklu, Bal Kocyigit and Kose [10], in the model system that designed and developed, the measurements of the prepared samples were carried out and the sound pressure levels, whose unit is dB, and the Sound Transmission Loss values were analyzed and the results were compared.

In order to suppress unwanted sounds (noise) in acoustic materials, the process of providing Sound Transmission Loss and the suppression of signals with electronic filters overlap. In the study, it was aimed to realize the electronic filter design as a result of the comparison of the experimental data. It is known that filters are widely used in circuit design [28]. By choosing a certain filter structure, the data can be filtered after both design and implementation [29]. In order to perform the filtering, the Sallen-Key Topology was used for the electronic filter design with the evaluated and appropriate data. Frequency-gain (amplitude) graphs were prepared and analyzed comparatively by using a special program for simulation.

2.1. Material

For the filter design, first of all, various acoustic materials were prepared and their acoustic tests were carried out. Buluklu, Bal Kocyigit and Kose, obtained the samples they prepared in their previous studies by placing recyclable materials such as pine cones and walnut shells flat on 1 cm thick gypsum board and giving egg shape to the pine cone pieces with gypsum [30]. The moving surface with these materials was tested by placing them facing the L_1 or L_2 chambers in the test box used in the test process, or by having 100% wool felt and/or heraclite between them. Used samples are given in Table 1.

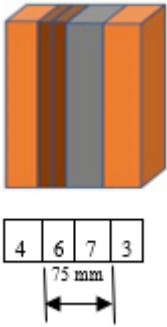
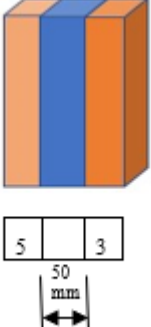
Table 1. Used samples

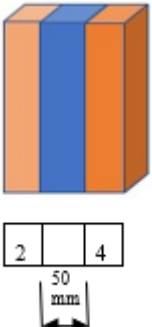
 <p>(1) A Sample: 1,5 cm thick sample containing gypsum-pine cones</p>	 <p>(2) B Sample: 2 cm thick sample containing gypsum-pine cones</p>	 <p>(3) C Sample: 4 cm thick egg-shaped sample containing gypsum-pine cones</p> <p>(According to test result L₁-L₂)</p>	 <p>(4) D Sample: 1,5 cm thick sample containing convex walnut shell</p>	 <p>(5) It was used in sample F: 2 cm thick sample containing concave walnut shell</p>	 <p>(6) It was used in sample E: %100 Wool felt</p>	 <p>(7) It was used in sample E: 2,5 cm thick heraclite</p>
 <p>4: 1,5 cm thick sample containing convex walnut shell 6: 2 pieces %100 wool felt 7: 2,5 cm heraclite 3: 4 cm thick egg-shaped sample containing gypsum-pine cones</p> <p>E Composite Sample</p>	 <p>5: 2 cm thick sample containing concave walnut shell 3: 4 cm thick egg-shaped sample containing gypsum-pine cones</p> <p>F Composite Sample</p>	 <p>(According to test result L₂-L₁)</p> <p>G Sample: 4 cm thick egg-shaped sample containing gypsum-pine cones</p>	 <p>2: 2 cm thick sample containing gypsum-pine cones 4: 1,5 cm thick sample containing convex walnut shell</p> <p>H Composite Sample</p>			

In Table 1, samples E, F and H are composite structures and samples 5, 6 and 7 were used in their preparation. As the material in the study; the suppression gain values of the samples tested at frequencies of 500, 1000, 2000, 4000 and 8000 Hertz (Hz.) were used and taken in decibel (dB).

In order to realize the filter design, filter design was tried to be made by using the measurement values of some samples as a result of the experiment. In the design, it can be ensured that the design space and performance characteristics can be optimized [29]. In addition to providing optimization, there are also important different parameters. One of these parameters is to perform the frequency dependent change of a data [31]. Another method used is known as the use of approximation methods in filter design. The reason for using this is expressed as the oscillations occurring at sharp cut-off frequencies of the filters [32]. dB is used to detect the gain or loss that occurs in the path of the signal [33]. The suppression gain values of samples A, B, C, D, E, F, G and H according to frequencies are given in Table 2.

Table 2. Suppression gain values of samples A, B, C, D, E, F, G and H according to frequencies

<table border="1"> <thead> <tr> <th>Frequency (Hz.)</th> <th>Input Power</th> <th>Output Power</th> <th>Supression Gain (dB)</th> </tr> </thead> <tbody> <tr> <td>500</td> <td>85,2</td> <td>82,3</td> <td>3</td> </tr> <tr> <td>1000</td> <td>90,9</td> <td>77,3</td> <td>13,6</td> </tr> <tr> <td>2000</td> <td>98,4</td> <td>75,7</td> <td>22,7</td> </tr> <tr> <td>4000</td> <td>77,3</td> <td>46,1</td> <td>31,2</td> </tr> </tbody> </table> <p style="text-align: center;">A Sample</p>	Frequency (Hz.)	Input Power	Output Power	Supression Gain (dB)	500	85,2	82,3	3	1000	90,9	77,3	13,6	2000	98,4	75,7	22,7	4000	77,3	46,1	31,2	<table border="1"> <thead> <tr> <th>Frequency (Hz.)</th> <th>Input Power</th> <th>Output Power</th> <th>Supression Gain (dB)</th> </tr> </thead> <tbody> <tr> <td>500</td> <td>76,6</td> <td>75,8</td> <td>0,8</td> </tr> <tr> <td>1000</td> <td>95,8</td> <td>81,4</td> <td>14,4</td> </tr> <tr> <td>2000</td> <td>102,2</td> <td>77,5</td> <td>24,7</td> </tr> <tr> <td>4000</td> <td>87,7</td> <td>48,2</td> <td>39,5</td> </tr> </tbody> </table> <p style="text-align: center;">B Sample</p>	Frequency (Hz.)	Input Power	Output Power	Supression Gain (dB)	500	76,6	75,8	0,8	1000	95,8	81,4	14,4	2000	102,2	77,5	24,7	4000	87,7	48,2	39,5	<table border="1"> <thead> <tr> <th>Frequency (Hz.)</th> <th>Input Power</th> <th>Output Power</th> <th>Supression Gain (dB)</th> </tr> </thead> <tbody> <tr> <td>500</td> <td>85,3</td> <td>85,1</td> <td>0,2</td> </tr> <tr> <td>1000</td> <td>95,5</td> <td>85,1</td> <td>10,5</td> </tr> <tr> <td>2000</td> <td>97,6</td> <td>77,8</td> <td>19,8</td> </tr> <tr> <td>4000</td> <td>84,2</td> <td>53,8</td> <td>30,4</td> </tr> </tbody> </table> <p style="text-align: center;">C Sample</p>	Frequency (Hz.)	Input Power	Output Power	Supression Gain (dB)	500	85,3	85,1	0,2	1000	95,5	85,1	10,5	2000	97,6	77,8	19,8	4000	84,2	53,8	30,4
Frequency (Hz.)	Input Power	Output Power	Supression Gain (dB)																																																											
500	85,2	82,3	3																																																											
1000	90,9	77,3	13,6																																																											
2000	98,4	75,7	22,7																																																											
4000	77,3	46,1	31,2																																																											
Frequency (Hz.)	Input Power	Output Power	Supression Gain (dB)																																																											
500	76,6	75,8	0,8																																																											
1000	95,8	81,4	14,4																																																											
2000	102,2	77,5	24,7																																																											
4000	87,7	48,2	39,5																																																											
Frequency (Hz.)	Input Power	Output Power	Supression Gain (dB)																																																											
500	85,3	85,1	0,2																																																											
1000	95,5	85,1	10,5																																																											
2000	97,6	77,8	19,8																																																											
4000	84,2	53,8	30,4																																																											
<table border="1"> <thead> <tr> <th>Frequency (Hz.)</th> <th>Input Power</th> <th>Output Power</th> <th>Supression Gain (dB)</th> </tr> </thead> <tbody> <tr> <td>500</td> <td>84,1</td> <td>77,3</td> <td>6,8</td> </tr> <tr> <td>1000</td> <td>96,8</td> <td>78</td> <td>18,8</td> </tr> <tr> <td>2000</td> <td>105,6</td> <td>65,4</td> <td>40,2</td> </tr> <tr> <td>4000</td> <td>82,9</td> <td>42,3</td> <td>40,6</td> </tr> </tbody> </table> <p style="text-align: center;">D Sample</p>	Frequency (Hz.)	Input Power	Output Power	Supression Gain (dB)	500	84,1	77,3	6,8	1000	96,8	78	18,8	2000	105,6	65,4	40,2	4000	82,9	42,3	40,6	<table border="1"> <thead> <tr> <th>Frequency (Hz.)</th> <th>Input Power</th> <th>Output Power</th> <th>Supression Gain (dB)</th> </tr> </thead> <tbody> <tr> <td>500</td> <td>83,50</td> <td>76,40</td> <td>7,10</td> </tr> <tr> <td>1000</td> <td>94,90</td> <td>74,77</td> <td>20,10</td> </tr> <tr> <td>2000</td> <td>100,7</td> <td>76,37</td> <td>24,33</td> </tr> <tr> <td>4000</td> <td>71,13</td> <td>45,27</td> <td>25,87</td> </tr> </tbody> </table> <p style="text-align: center;">E Sample</p>	Frequency (Hz.)	Input Power	Output Power	Supression Gain (dB)	500	83,50	76,40	7,10	1000	94,90	74,77	20,10	2000	100,7	76,37	24,33	4000	71,13	45,27	25,87	<table border="1"> <thead> <tr> <th>Frequency (Hz.)</th> <th>Input Power</th> <th>Output Power</th> <th>Supression Gain (dB)</th> </tr> </thead> <tbody> <tr> <td>500</td> <td>86,4</td> <td>72,3</td> <td>14,1</td> </tr> <tr> <td>1000</td> <td>92,9</td> <td>79</td> <td>14</td> </tr> <tr> <td>2000</td> <td>103,8</td> <td>68,2</td> <td>35,6</td> </tr> <tr> <td>4000</td> <td>80,6</td> <td>38,5</td> <td>42,1</td> </tr> </tbody> </table> <p style="text-align: center;">F Sample</p>	Frequency (Hz.)	Input Power	Output Power	Supression Gain (dB)	500	86,4	72,3	14,1	1000	92,9	79	14	2000	103,8	68,2	35,6	4000	80,6	38,5	42,1
Frequency (Hz.)	Input Power	Output Power	Supression Gain (dB)																																																											
500	84,1	77,3	6,8																																																											
1000	96,8	78	18,8																																																											
2000	105,6	65,4	40,2																																																											
4000	82,9	42,3	40,6																																																											
Frequency (Hz.)	Input Power	Output Power	Supression Gain (dB)																																																											
500	83,50	76,40	7,10																																																											
1000	94,90	74,77	20,10																																																											
2000	100,7	76,37	24,33																																																											
4000	71,13	45,27	25,87																																																											
Frequency (Hz.)	Input Power	Output Power	Supression Gain (dB)																																																											
500	86,4	72,3	14,1																																																											
1000	92,9	79	14																																																											
2000	103,8	68,2	35,6																																																											
4000	80,6	38,5	42,1																																																											
<table border="1"> <thead> <tr> <th>Frequency (Hz.)</th> <th>Input Power</th> <th>Output Power</th> <th>Supression Gain (dB)</th> </tr> </thead> <tbody> <tr> <td>500</td> <td>92,5</td> <td>78</td> <td>14,5</td> </tr> <tr> <td>1000</td> <td>93,9</td> <td>82,3</td> <td>11,5</td> </tr> <tr> <td>2000</td> <td>99,9</td> <td>79,3</td> <td>20,6</td> </tr> <tr> <td>4000</td> <td>79,6</td> <td>52,8</td> <td>26,8</td> </tr> </tbody> </table> <p style="text-align: center;">G Sample</p>	Frequency (Hz.)	Input Power	Output Power	Supression Gain (dB)	500	92,5	78	14,5	1000	93,9	82,3	11,5	2000	99,9	79,3	20,6	4000	79,6	52,8	26,8	<table border="1"> <thead> <tr> <th>Frequency (Hz.)</th> <th>Input Power</th> <th>Output Power</th> <th>Supression Gain (dB)</th> </tr> </thead> <tbody> <tr> <td>500</td> <td>80,03</td> <td>71,73</td> <td>8,3</td> </tr> <tr> <td>1000</td> <td>94,63</td> <td>76,20</td> <td>18,4</td> </tr> <tr> <td>2000</td> <td>97,53</td> <td>67,97</td> <td>29,6</td> </tr> <tr> <td>4000</td> <td>81,67</td> <td>41,87</td> <td>39,8</td> </tr> </tbody> </table> <p style="text-align: center;">H Sample</p>	Frequency (Hz.)	Input Power	Output Power	Supression Gain (dB)	500	80,03	71,73	8,3	1000	94,63	76,20	18,4	2000	97,53	67,97	29,6	4000	81,67	41,87	39,8																					
Frequency (Hz.)	Input Power	Output Power	Supression Gain (dB)																																																											
500	92,5	78	14,5																																																											
1000	93,9	82,3	11,5																																																											
2000	99,9	79,3	20,6																																																											
4000	79,6	52,8	26,8																																																											
Frequency (Hz.)	Input Power	Output Power	Supression Gain (dB)																																																											
500	80,03	71,73	8,3																																																											
1000	94,63	76,20	18,4																																																											
2000	97,53	67,97	29,6																																																											
4000	81,67	41,87	39,8																																																											

The samples given in Table 2 are identified by the letters A, B, C, D, E, F, G, and H, respectively. The suppression gain values for each frequency are taken as negative (-) in the graphic drawings for the filter circuit design. The graphs of the suppression gain values of the samples according to the frequencies are given in Table 3.

Table 3. Graphs of frequency-suppression gain values of samples A, B, C, D, E, F, G and H

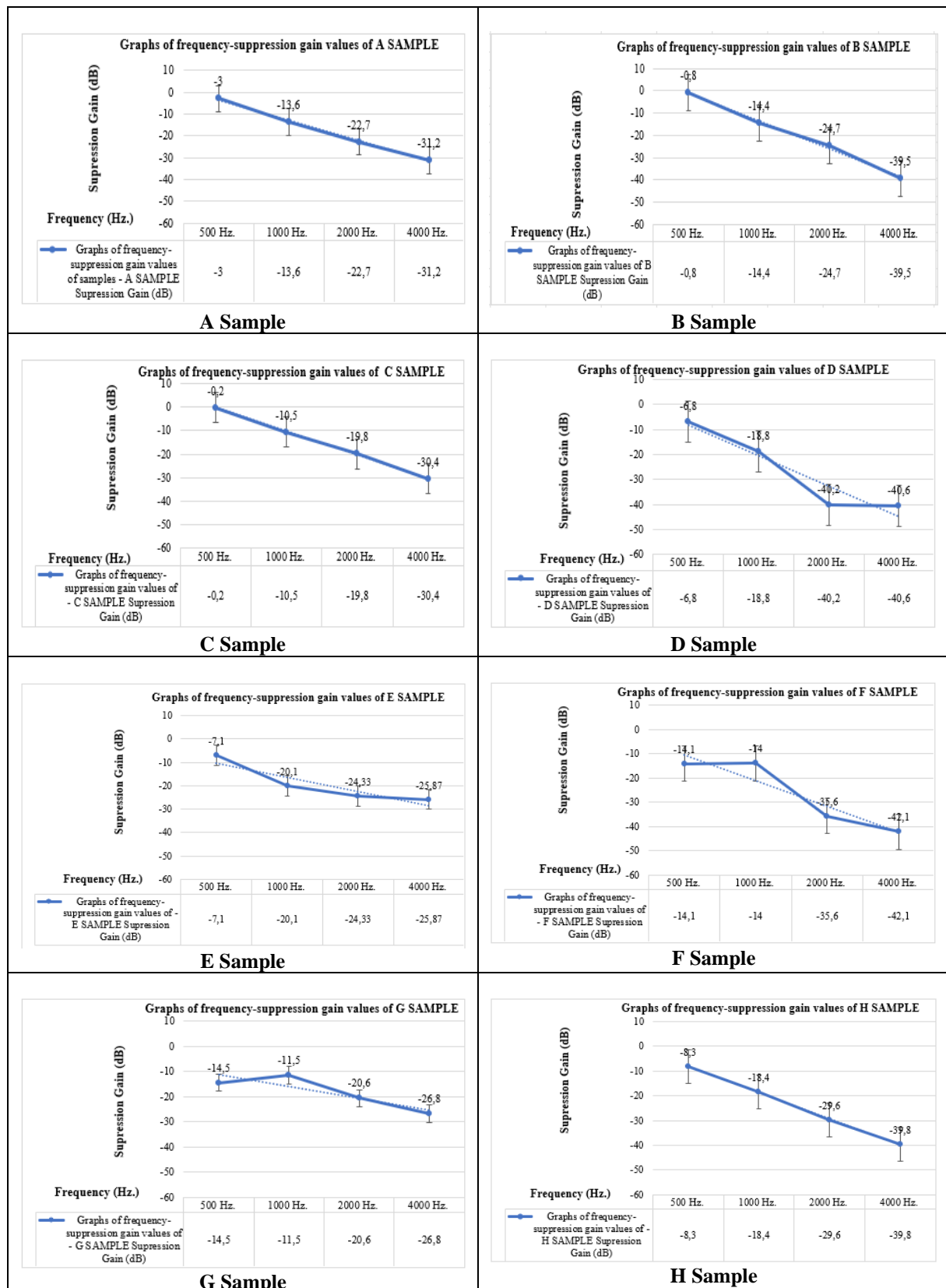

According to the suppression gain curves in the graph given in Table 3, it is predicted that a low-pass filter can be designed. The frequencies in the chart are arranged according to 500, 1000, 2000 and 4000 Hz.

2.2. Method

Mathematical models have been developed to reflect the behavior of physical or biological systems in order to answer questions of interest. Statistical models can take many descriptive forms, such as dynamic systems, differential equations, or game theory models [34].

In addition to the structural features, filtering operations, transfer function while simulating according to certain frequencies calculation is needed. It is known that the transfer function is an equation calculated by dividing the output voltage by the input voltage depending on the frequency. A visualization of a transfer function is given in Figure 1 [28].

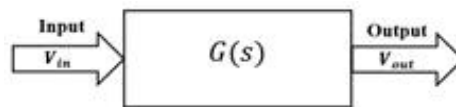

Figure 1. Illustration of a transfer function [28]

As V_{in} is input voltage and V_{out} is output voltage, the transfer function of the system which shown in Figure 1, can be given as in transfer function (G(s)) Equation (1)

$$G(s) = \frac{V_{out}(s)}{V_{in}(s)}. \quad (1)$$

In order to obtain the transfer functions of the samples, active electronic filter structure simulation is used. Today, filters are used in many fields. For example, in the communication system, filters can generally be used to remove noise and adjust at certain range frequencies [35]. Active filter types (low pass, high pass, band pass, band reject and all pass filters) can be encountered in different applications [21]. The most used Sallen-Key filter [36] was chosen for this study, and it is also known to be an electronic filter topology. An active filter structure is given in Figure 2 [37].

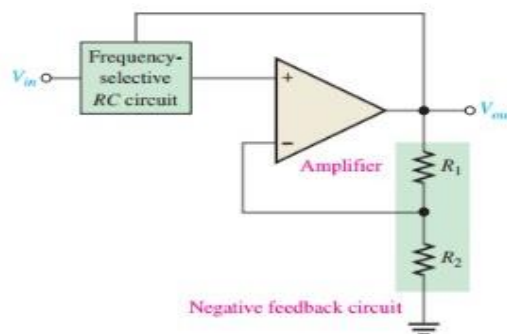

Figure 2. An active filter structure [37]

For modeling in the acoustic field, it has been stated that by using the Comet Trim etc programs, it can prevent the application without knowing the material properties exactly, and it can also help to find the desired material combinations for different applications [7]. In this study, TINA-TI and MATLAB programs and electronic active filter design structure were used for mathematical modeling of the samples. Active filters seen in Figure 2 are circuits containing active materials (transistor or operational amplifier), resistor, coil and capacitance [38]. R_1 and R_2 shown in the Figure 2 are resistors, RC resistor- capacitor. The second-order Sallen-Key low-pass filter structure is given in Figure 3 [37].

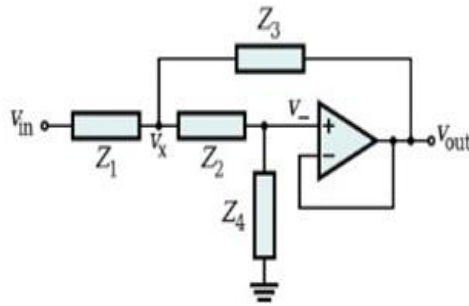

Figure 3. Second-order Sallen-Key low-pass filter [37]

Sallen-Key low-pass filter circuit V_x in Figure 3, its value is calculated by V_x Equation (2). Z_1, Z_2, Z_3 and Z_4 shown in the Figure 3 are impedances

$$V_x = V_{out} \left(\frac{Z_2}{Z_4} + 1 \right). \tag{2}$$

Low pass filter, DC to it is an electronic circuit that can have a constant output voltage (from low-level linear current) to the cutoff frequency. If the frequency starts to rise above the cutoff frequency, the output voltage starts to decrease. The cut off frequency (0.707 frequency) is 3 dB or the corner frequency is expressed as the frequency at which the output voltage drops 0.707 times compared to the pass-band value. An active low-pass filter circuit is given in Figure 4 [38].

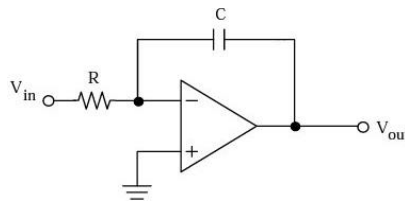

Figure 4. A low-pass filter circuit [38]

The circuit shown in Figure 4 is called an inverting integrator or Miller integrator. C given in Figure 4 is the symbol of the capacitor. The Miller integrator can be found to be a low pass filter by $\frac{V_{out}(S)}{V_{in}(S)}$, S, It can be obtained as a time-dependent function, or it can be expressed depending on the "s" function in the complex number plane obtained by the laplas transformation independent of the time plane Equation (3) and ω_0 Equation (4)

$$\frac{V_{out}(S)}{V_{in}(S)} = \frac{-1}{SC} = \frac{-1}{RC} = -\frac{\omega_0}{S} \tag{3}$$

$$\omega_0 = \frac{1}{RC} . \tag{4}$$

Second-order low-pass filter can be formed by connecting two miller integrator circuits and an inverting amplifier cascade. The block diagram of a quadratic filter is given in Figure 5 [38]. ω_0 is the represents the cutoff frequency, Q is the represents the quality factor are given in Figure 5.

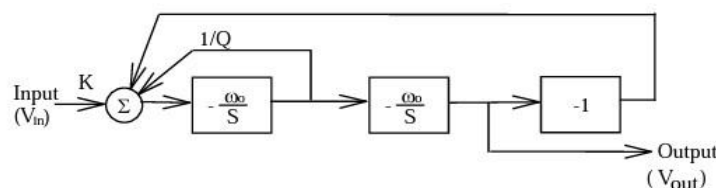

Figure 5. Block diagram of a quadratic filter [38]

The quadratic filter shown in Figure 5, consists of two miller integrators, a unit gain inverter amplifier and an adder. Accordingly, the transfer function becomes the expression in $\frac{V_{out}(S)}{V_{in}(S)}$ Equation (5), [38]. K is the gain in the Equality (5).

$$\frac{V_{out}(S)}{V_{in}(S)} = \frac{KW_0^2}{s^2 + \left(\frac{W_0}{Q}\right)s + W_0^2} \quad (5)$$

In filter topologies, the amplitude of a signal is measured in volts [33]. In Tables 1 and 2, the most suitable low-pass filter for frequency dependent gain suppression ratio characteristic curves is given in Figure 6 [39].

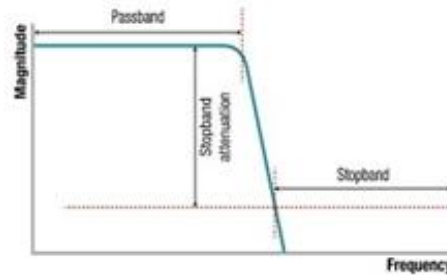

Figure 6. Low-pass filter characteristic curve [39]

In this study, TINA-TI program was used for filter simulation. TINA-TI simulation program, toolkit for interactive network analysis, is known to be a SPICE-based electronic design and training software developed by Design Soft [39]. Appropriate frequency ranges should be selected in designing filter types such as low-pass and high-pass filters [40]. In the experimental study, as a result of defining the frequencies in the range of 500-4000 Hz. where the measurements are made and the suppression gains to the program, the gain (amplitude)-frequency (magnitude response) graphics (in dB) and circuit topologies were created. In the study, circuit topologies can be drawn in the TINA-TI program by calculating the transfer functions with the R and C values in the circuit topologies of each of the samples [41]. On circuit topologies, input and output voltage values for 500, 1000, 2000, 4000 Hz. frequencies and suppression gain values can be calculated with the help of *Gain (dB)* Equation (6)

$$Gain(dB) = 20 * \log \frac{Output}{Input} \quad (6)$$

The data obtained as a result of the calculations made according to *Gain (dB)*, (6); It can be analyzed by comparing the gain (amplitude)-frequency values calculated according to the experimental results and transfer functions. In order to calculate the suppression gains depending on the transfer functions, the use of MATLAB program was preferred. It is known that the MATLAB Program is a preferred program due to its ease of use and breadth of use, which ensures that the results of a work at the project stage are predictable. With computer programs such as MATLAB/Simulink, static, continuous, dynamic etc. modeling, it allows simulation and analysis [42]. By defining the data in the transfer functions of each sample in the study with the appropriate instructions in the MATLAB program, the gain (amplitude)-frequency (magnitude) known as the “Bode Diagram” response graphics are obtained. Sine wave is used as input signal while calculating the suppression gain values. An example sine wave is given in Figure 7.

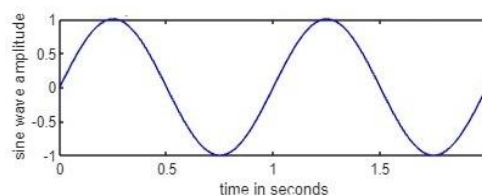

Figure 7. Sine wave

Samples using suppression gain values in this study can be considered to exhibit characteristic behavior like a filter. The appearance of the frequencies and wavelengths affecting the input signal according to the frequencies of 500, 1000, 2000 and 4000 Hz. are given in Figure 8.

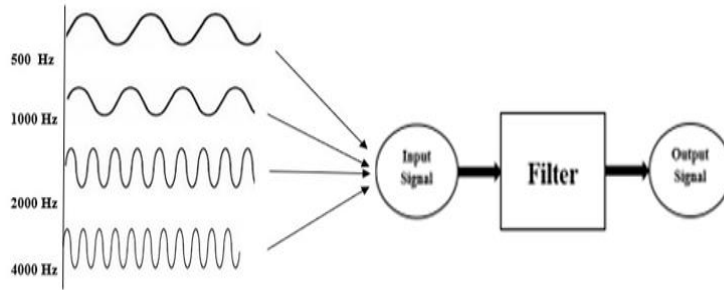

Figure 8. Filter input and output simulation model of input signals with varying wavelengths depending on the frequency

According to Figure 8, the frequency of sine waves is less at 500 Hz, and the frequency of wavelengths increases as the frequency increases. Accordingly, the suppression gain data from the output signal is calculated using Magnitude in the MATLAB program. It was obtained separately for 500, 1000, 2000 and 4000 Hz. frequencies on the curve in the response graph. The obtained values and the experimental gain (amplitude)-frequency, results are in agreement with each other.

3. RESULTS

In the study; the experimental results of A, B, C, D, E, F, G and H samples were interpreted by making comparisons and analyzes with gain (amplitude)-frequency, suppression gain according to active filter circuit and suppression gain values calculated according to transfer function in MATLAB program. Input voltage for all samples is 10 mV taken as. Output voltage values vary. Calculations according to the constant and variable values are given according to the samples.

3.1. A Sample

For the A sample according to the frequencies of 500-4000 Hz. are given in Table 2. The transfer function calculated using OKAWA Electric Design and MATLAB programs and Equations (1) and (2) according to the suppression gain values in Table 2 is given in $G(s)$, Equation (7)

$$G(s) = \frac{19570543.98}{s^2 + 7652.08s + 19570543.98} \quad (7)$$

The characteristic behavior of any system can be realized by looking at the positions of the eigenvalues. The roots of the denominator of the transfer function of the system in question show the eigenvalues. According to transfer function given in $G(s)$ Equation (7), eigenvalues λ_{A1} , λ_{A2} Equation (8) and its graph are given in Figure 9.

$$\begin{aligned} \lambda_{A1} &= (-3.8260 + 2.2208i)10^3 \\ \lambda_{A2} &= (-3.8260 - 2.2208i)10^3 \end{aligned} \quad (8)$$

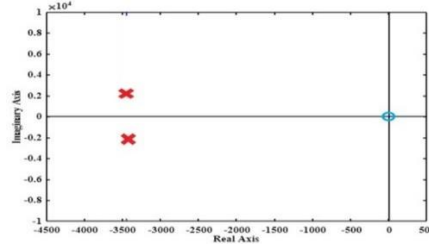

Figure 9. Eigenvalue plot for sample A

According to the calculation in $G(s)$ Equation (7), comparison of the suppression gain values for sample A in the frequency range of 500-4000 Hz., is given in Table 4.

Table 4. Comparison of suppression gain values for sample A

Frequency (Hz.)	Suppression Gain (dB) Calculated As A Result Of The Experiment	Suppression Gain (dB) According to the Gain (Amplitude)-Frequency Graph Drawn in TINA-TI Program	Suppression Gain (dB) According to Active Filter Circuit	Suppression Gain Calculated According to Transfer Function in MATLAB Program (dB)
500	-3	-2.5	-2.44	-2.85
1000	-13.6	-8.75	-8.49	-11.3
2000	-22.7	-19.15	-18.7	-18.2
4000	-31.2	-30.93	-30.33	-30.1

According to Table 4; According to the measurements made in the frequency range of 500-4000 Hz; at a frequency of 4000 Hz. of the highest values; The gain (amplitude)-frequency graph (-30.93 dB) with approximately experiment (-31.2 dB) and the suppression gain (-30.33 dB) according to the active filter circuit, the suppression gain calculated according to the transfer function in the MATLAB program (-30.1 dB), it is seen that they are close to each other. Since the suppression gain values calculated according to the transfer function in the MATLAB program are compatible with other data, it has been determined that a suitable electronic filter circuit structure can be designed according to the test results.

On the other hand, it is known that the cutoff frequency is an important parameter in the design of the electronic filter circuit structure. The cutoff frequency shows us the point at which the signal flowing through the system starts to be de-energized. At the cutoff frequency, the low frequency gain is reduced by 3 dB. The amount of gain at the cutoff frequency is given in Figure 10 [37].

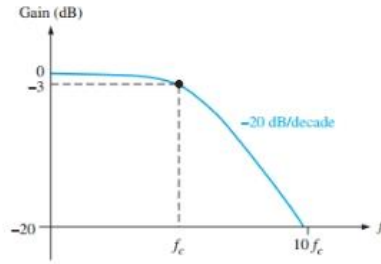

Figure 10. Amount of gain at cutoff frequency [37]

fc Equation (9) can also be used to calculate the Sallen-Key low-pass filter cut off frequency [43].

$$f_c = \frac{1}{2\pi\sqrt{R_A R_B C_A C_B}} \tag{9}$$

The cut off frequency value of sample A was calculated approximately in fc Equation (10) with the R and C values in the circuit topology given in Table 3.

$$f_c = \frac{1}{2\pi\sqrt{R_A R_B C_A C_B}} = \frac{1}{2\pi\sqrt{1.54k\Omega * 2.37k\Omega * 100.10^{-3}\mu F * 140.10^{-3}\mu F}} = 0.704 \text{ kHz} \Rightarrow 704 \text{ Hz.} \tag{10}$$

Cut off frequency of 704 Hz. calculated for sample A in fc (10) is given in Figure 11.

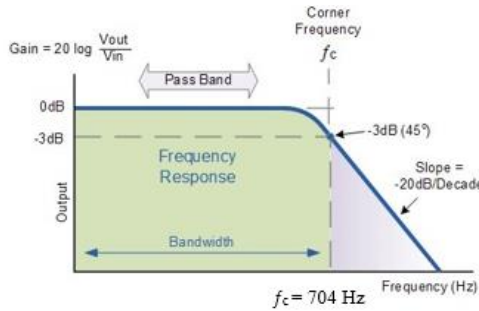

Figure 11. Cut off frequency of sample A [37]

The transfer function, cut off frequency and eigenvalues of the B, C, D, E, F, G and H samples in the study were prepared and summarized in Table 5.

Table 5. B, C, D, E, F, G and H samples; transfer functions, cutoff frequencies and eigenvalues are given

Sample First Name	Transfer Function $(G(s) = \frac{V_{out}}{V_{in}})$	Cut off Frequency (Hz.) $(f_c = \frac{1}{2\pi\sqrt{R_A R_B C_A C_B}})$	Eigenvalues
B and C	$G(s) = \frac{15829747.89}{s^2 + 6901.77s + 15829747.89}$	=633	$\lambda_{A1} = (-3.4509 + 1.9802i)10^3$ $\lambda_{A2} = (-3.4509 - 1.9802i)10^3$
D	$G(s) = \frac{5771539.38}{s^2 + 4167.05s + 5771539.38}$	=382	$\lambda_{A1} = (-2.0835 + 1.1960i)10^3$ $\lambda_{A2} = (-2.0835 - 1.1960i)10^3$
E	$G(s) = \frac{12992209.87}{s^2 + 6249.25s + 12992209.87}$	=574	$\lambda_{A1} = (-3.1246 + 1.7969i)10^3$ $\lambda_{A2} = (-3.1246 - 1.7969i)10^3$
F and H	$G(s) = \frac{4016903.12}{s^2 + 3466.58s + 4016903.12}$	=319	$\lambda_{A1} = (-1.7333 + 1.0063i)10^3$ $\lambda_{A2} = (-1.7333 - 1.0063i)10^3$
G	$G(s) = \frac{7859484.98}{s^2 + 4849.30s + 7859484.98}$	=446	$\lambda_{A1} = (-2.4247 + 1.4073i)10^3$ $\lambda_{A2} = (-2.4247 - 1.4073i)10^3$

The simulated transfer function structures of the samples can be used for the steady state analysis of the systems. Accordingly, when the eigenvalues of the samples are examined, complex conjugates appear to have root structure. This complex conjugates can be expressed in the form of root structures. $a \pm jb$ In line with this structure, the stability and behavioral states of the systems can be revealed. For this, the sign of the real part of the complex number can be examined. So, $a < 0, a > 0$ or $a = 0$ their situation is examined. All of the eigenvalues of the transfer functions obtained within the scope of this study are complex. It is seen that conjugates have roots and their real parts ($a < 0$) are negative. Depending on the time of the systems the complex damped harmonic oscillator shape and phase stable as a plane It is expected to behave in a spiral shape [44, 45]. This behavior is also seen in the signal outputs obtained from the sinus signal inputs at 500-4000 Hz. input frequency values for sample A, which are shown in Figure 8.

Comparisons of suppression gain values for B, D, E, F and G samples are given in Table 6. Experimental results and other results were obtained in agreement with each other.

Table 6. Comparison of suppression gain values for B, D, E, F, G samples

Frequency (Hz.)	Suppression Gain Obtained After Experiment (dB)					Suppression Gain (dB) According to the Gain (Amplitude)-Frequency Graph Drawn in TINA-TI Program					Suppression Gain (dB) According to Active Filter Circuit					Suppression Gain Calculated According to Transfer Function in MATLAB Program (dB)				
	B	D	E	F	G	B	D	E	F	G	B	D	E	F	G	B	D	E	F	G
500	-0.8	-6.8	-7.1	-14.1	-14.5	-3	-7.83	-3.84	-10.2	-6.24	-3.04	-7.5	-3.69	-9.76	-5.82	-5.85	-10.4	-6.61	-13.1	-8.9
1000	-14.4	-18.8	-20.1	-14	-11.5	-9.8	-17.9	-11.7	-20.8	-14.9	-9.88	-17.4	-11.2	-20.3	-14.9	-12.2	-18.6	-13.3	-21	-19.8
2000	-24.7	-40.2	-24.3	-35.6	-20.6	-20.3	-29.5	-22.7	-32.6	-26.3	-20.4	-28.9	-22.1	-32	-26.3	-20	-28	-21	-34	-25
4000	-39.5	-40.6	-25.9	-42.1	-26.8	-32	-40.4	-33.7	-43.7	-38.4	-32.2	-40.8	-33.8	-44	-38.2	-33	-38	-31	-42	-36

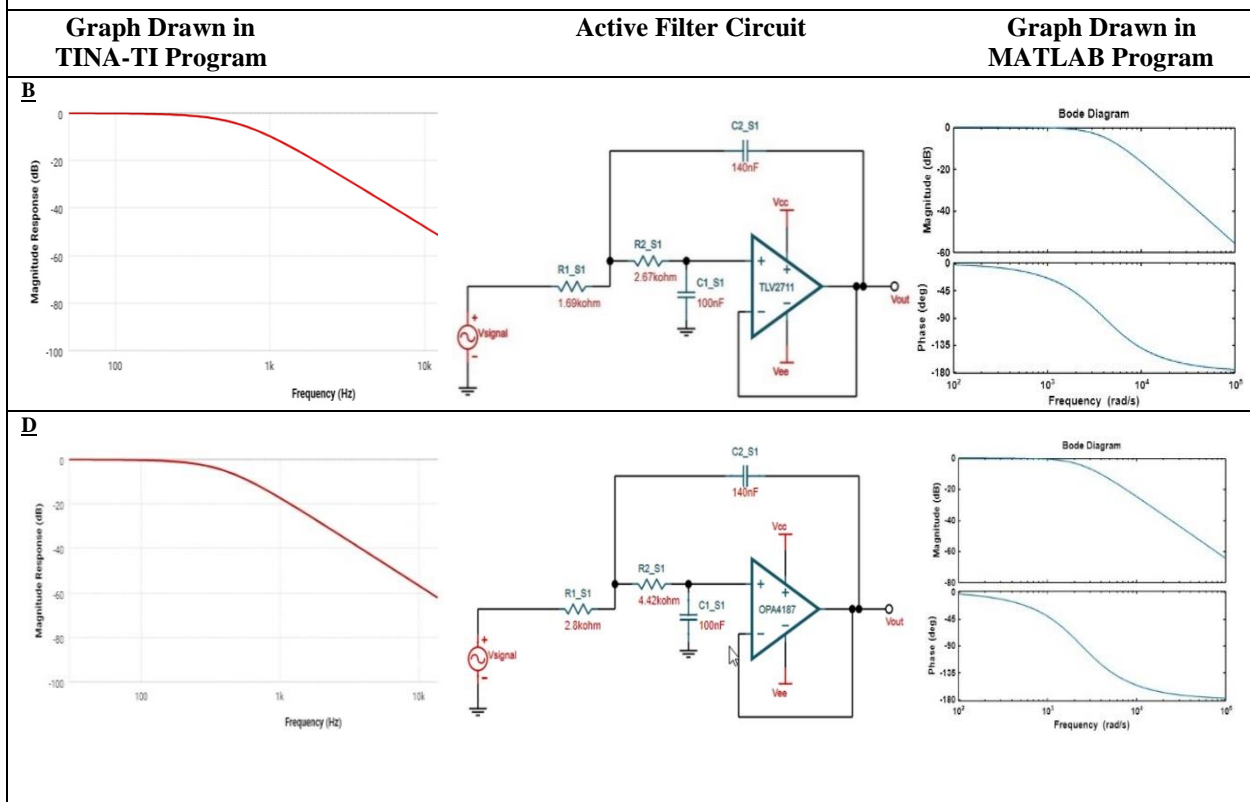

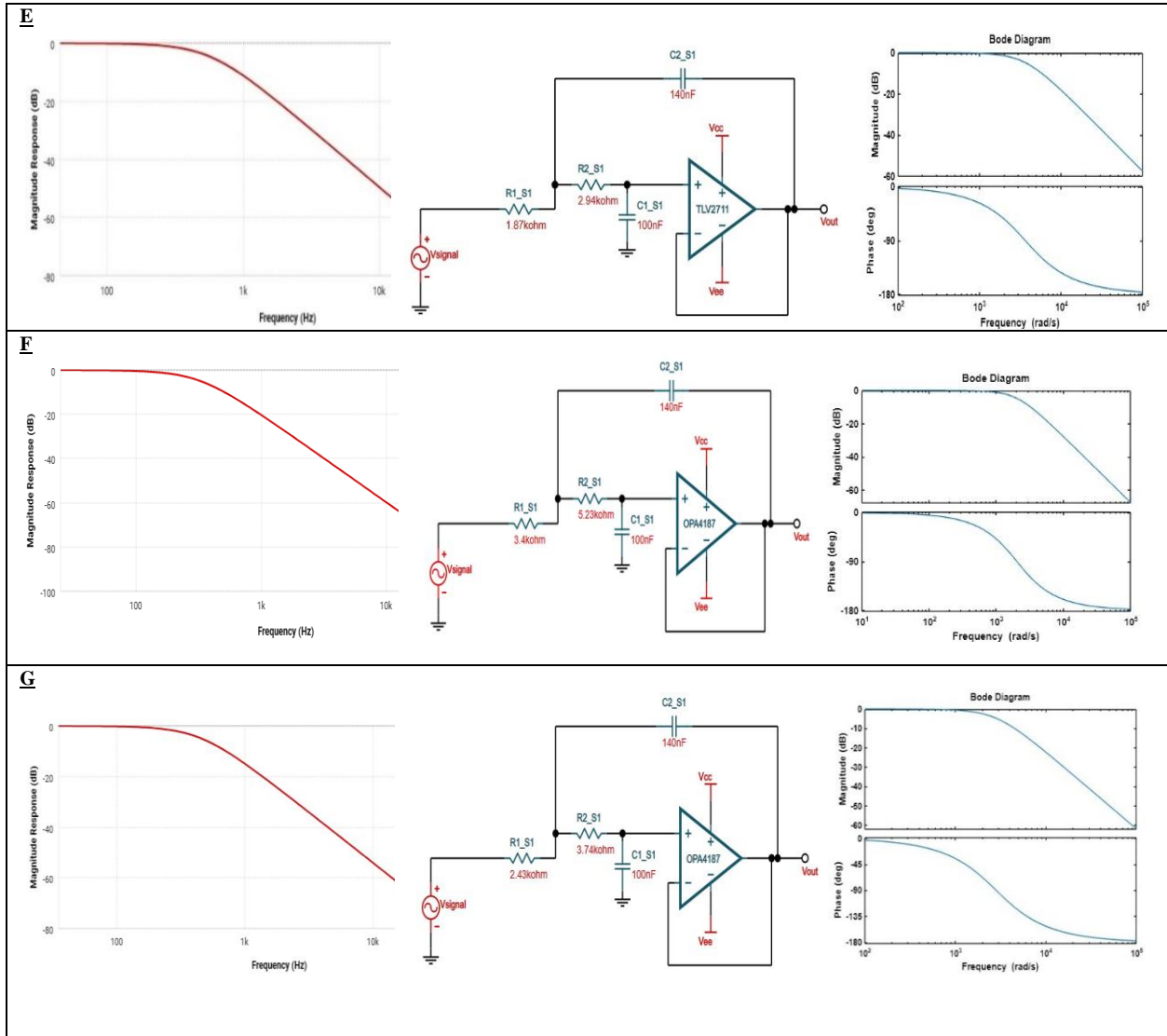

Since the test results of B and C, F and H samples and the results obtained from the processes in the programs used in the study are close to each other, the electronic filter circuit topologies have the same appearance. Therefore, in Table 5; values of sample B, F and F from H are given from B and C.

4. RESULTS AND DISCUSSION

Mathematical modeling design was carried out according to the Sound Transmission Loss values of A, B, C, D, E, F, G and H prepared with natural ingredients. In TINA -TI program, low-pass the gain (amplitude)-frequency graphs drawn according to the Sallen-Key active filter structure and the suppression gain (dB) values calculated from the active filter circuit and the transfer function in the MATLAB program were compared with the experimental results. Since the experimental results of samples B, C, F and H and the results obtained from the operations in the programs used in the study were close to each other, it was determined that the electronic filter circuit topologies had the same appearance. According to the study carried out in the frequency range of 500-4000 Hz., it was observed that all values were close to each other and the highest values were in the range of approximately 35-45 dB in the frequency range of 2000-4000 Hz. The cut-off frequencies are approximately; it was calculated as 704 Hz. in A sample, 633 Hz. in C sample, 574 Hz. in E sample and 319 Hz. in F sample.

A, B, C, D, E, F, G and H samples were modeled in the MATLAB Simulink software environment and it was seen that the graphics were close according to the input and output quantities. Sine wave plots of sample A for 500, 1000, 2000 and 4000 Hz. are given in Figure 12. It can be seen that as the frequency of the sine

input signal increases, the output sine signal is suppressed with a higher gain. That is, as the input signal frequency increases, it is understood that the sinus output with lower gain is obtained at the output.

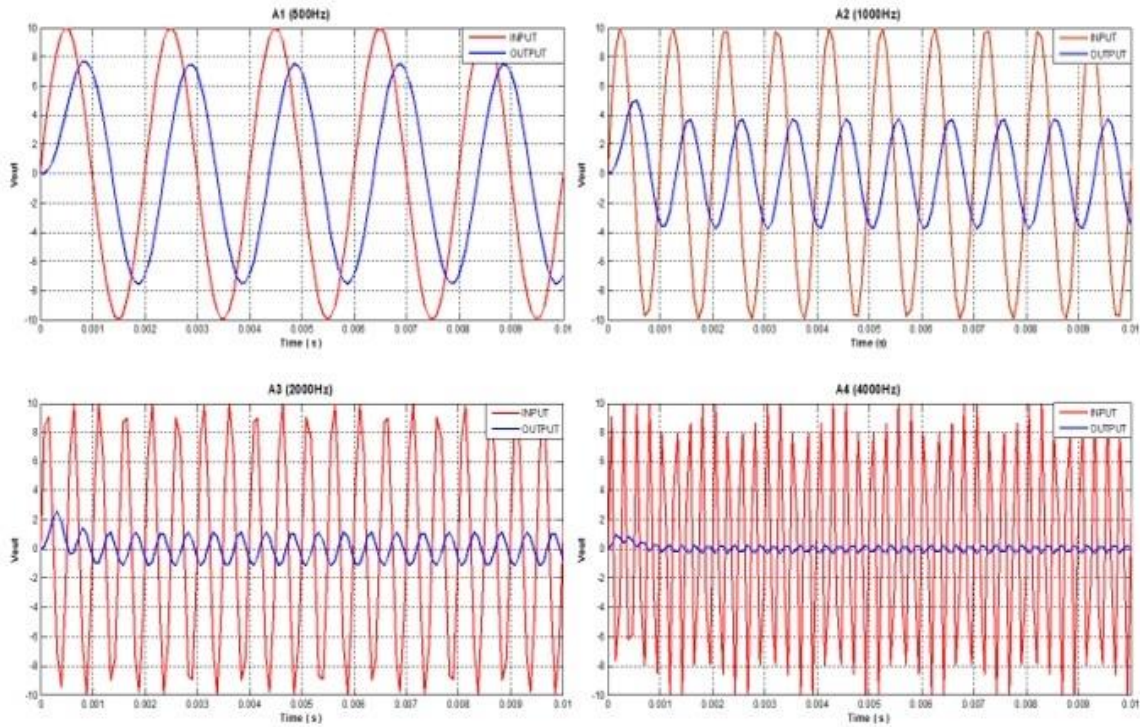

Figure 12. Plots of the sine wave of sample A

The suppression gain values and bode diagrams of the samples A, B, C, D, E, F, G and H, which are demonstrate in Table 6 and Figure 12, calculated depending on the transfer functions are given comparatively. The bode diagrams of the four samples are given in Figure 13. The results showed a behavior compatible with the low-pass filter structure.

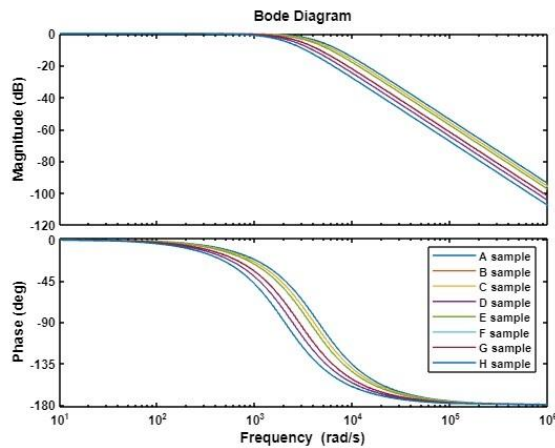

Figure 13. Bode diagrams of sample

5. CONCLUSION

In the study, the Sound Transmission Loss values, which were measured by preparing and testing with nature-friendly, less harmful and recyclable materials that can be grown in Turkey and are dense in some regions, were taken as the suppression gain and mathematical modeling was made in order to design the electronic filter circuit topology. Using the test results of the samples, a design has been made to produce new acoustic materials by removing the transfer function based on the electronic filter circuit design. As a

result of the analysis of the test results, the active Sallen-Key The low-pass filter structure was found suitable and mathematical modeling processes were carried out. In the 500, 1000, 2000 and 4000 Hz. fundamental frequency range, when the transfer function simulation suppression gain results are obtained in the TINA-TI program, the designed active filter circuit, and the MATLAB program, it has been determined that the values are close to each other and low-pass electronic filter circuit topologies can be designed. It is predicted that the method proposed in the study may be effective in modeling new materials with acoustic properties.

The potential for designing new acoustic materials based on the transfer function derived from electronic filter circuit design is an innovative approach. The study's prediction that this method may be effective in modeling new materials with improved acoustic properties opens up avenues for further exploration and application in various industries.

In conclusion, the integration of nature-friendly materials, electronic filter circuit design and mathematical modeling in the study presents a holistic approach to developing sustainable and effective acoustic solutions. The close alignment of simulation results from different programs adds credibility to the proposed method, and the potential for creating new acoustic materials holds promise for future advancements in the field.

Added Value:

More than one test can be done in a shorter time and at a lower cost. A cheap and effective Alpha Cabin system design has been proposed, which many commercial organizations can easily do their testing.

ACKNOWLEDGEMENTS

BAP Project Number: MF.21.006 (BAP: Tarsus University Scientific Research Projects): This study is supported by scientific research projects. We thank the Administration of Tarsus University for their support.

CONFLICTS OF INTEREST

No conflict of interest was declared by the authors.

REFERENCES

- [1] Europe, World Health Organization. "Night noise guidelines for Europe, World Health Organization Regional Office for Europe", Copenhagen. (https://ec.europa.eu/health/ph_projects/2003/action3/docs/2003_08_frep_en.pdf). Accessed 26 December (2022), (2009).
- [2] Bal Koçyiğit, F., "Acoustics in the under teenaged student'music classrooms", Engineering Science and Technology, an International Journal (JESTECH), Technology Journal, 13(2): 107-117, (2010).
- [3] Bal Koçyiğit, F., "Railway vibrations transmitted through the ground and the effect of vibrations on building case study from", Ankara Technology, 13(2): 71-83, (2010).
- [4] Buluklu, H. M., Koçyiğit, F. B., Köse, E., "Analysis of different methods of suppressing generator noise reaching indoor noise", European Mechanical Science, 6(3): 161-178, e-ISSN: 2587-1110, (2022).
- [5] Nazlier, M., "Industrial Plant Fires. Engineer and Machine Current", Local Periodical, 60(718): S: 23, (2019).
- [6] Verschaffel, L., Greer, B., De Corte, E., "Everyday knowledge and mathematical modeling of school word problems", Symbolizing, Modeling and Tool Use in Mathematics Education", 257-276. https://doi.org/10.1007/978-94-017-3194-2_16, (2002)

- [7] Vidinlimen, G. T., "Acoustic properties and analysis of porous materials used in automotive industry", (Doctoral dissertation, Institute of Science, (2010).
- [8] Mareze, P. H., Brandão, E., Fonseca, W. D. A., Silva, O. M., and Lenzi, A., "Modeling of acoustic porous material absorber using rigid multiple micro-ducts network: Validation of the proposed model", *Journal of Sound and Vibration*, 443: 376-396, (2019).
- [9] Kurtay, C., Eryıldız, D. I., Harputlugil, G. U., "Acoustical performance evaluation of Mimar Kemaleddin hall and alternatives for performance improvement", *Journal of Gazi University Faculty of Engineering and Architecture*, 23(3): 557-568, (2008).
- [10] Buluklu, H. M., Bal Koçyiğit, F., Köse, E., "Low-Cost Alpha Cabin like test box proposal for the development of new acoustic sound insulation materials", *Gazi University Journal of Science*. DOI: 10.35378/gujs.1010472, (2022)
- [11] Antoniou, A., "Digital signal processing. Signals Systems and Filters", McGraw-Hill New York Chicago San Francisco Lisbon London Madrid Mexico City Milan New Delhi San Juan Seoul Singapore Sydney Toronto, (2006).
- [12] Rumapea, H., Sitompul, D., Manalu, D.R., "Designing a media of active learning for teaching the passive high pass filter (PHPF) by developing its bode plot by using excel", *International Journal of Applied Engineering Research*, 16(8): 645-650, (2021).
- [13] Pactitis, S. A., "Active filters: theory and design", CRC Press, (2018).
- [14] Kalyani, V. L., Sharma, V., "Different types of optical filters and their realistic application", *Journal of Management Engineering and Information Technology (JMEIT)*, 3(3): (2016).
- [15] Kuphaldt, T.R., "Electric circuits II alternating current bellingham technical college", (2022).
- [16] Kalyani, V., Jadam, K., Padonia, K., Gupta, E., "Different types of active universal filters and their various applications", *Journal of Management Engineering and Information Technology*, 3(4): (2016).
- [17] Hiçdurmaz, B., Durak, F. E., Özyön, S., "The estimation of Bessel type low-pass active filter parameters with charged system search algorithm", *International Scientific and Vocational Studies Journal*, 3(2): 67-75, (2019).
- [18] Song, J., "Low-pass filter design and sampling theorem verification", In AIP conference proceedings, AIP Publishing LLC, 1971(1): 040017, (June, 2018).
- [19] Kuyu, Y. Ç., Vatansever, F., "Design of IIR digital filters using the current evolutionary algorithm", Published in 5th International Symposium on Innovative Technologies in Engineering and Science, (ISITES2017 Baku- Azerbaijan), (29-30 September 2017).
- [20] Jurišić, D., Mijat, N., Moschytz, G. S., "Design of Fourth-Order Band-Pass Active-RC Filters Using a "Lossy" Low-pass to Band-pass Transformation", In presentation on European Conference on Circuit Theory and Design, (August 2021).
- [21] Durrani, Y. A., "Design of fourth order active band-pass filter with sallen and key topology", *University of Engineering and Technology Taxila Technical Journal*, 21(3): 51, (2016).
- [22] Rüstemli, S., Cengiz, M. S., Dinçer, F., "Harmonics elimination and simulation using of active filters at power plants", *Bitlis Eren University (BEU) Journal of Science*, 2(1): 30-38, (2013).

- [23] Özer, E., “Designing of active harmonic filter for low power applications”, Ph.D. Thesis, Istanbul University, Institute of Graduate Studies in Science and Engineering, Department of Electrical and Electronic Engineering, Istanbul, (2015).
- [24] Yildiz, S., Aksen, A., Kilinc, S., Yarman, S. B., “Low pass filter design with improved stop-band suppression and synthesis with transformer-free ladders”, *The Institution of Engineering and Technology (IET) Circuits, Devices & Systems*, 15(6): 504-510, (2021).
- [25] Mülazımoğlu, C., Bağcı, F., Karakaya, E., Can, S., Yılmaz, A. E., Akaoğlu, B., “Low-pass microstrip using electronic band-gap structures filter design”, *URSI-Turkey’2016 VIII. Scientific Congress*, ODTÜ, Ankara, (1-3 September 2016)
- [26] Tekin, K., Güler, H., “CCCI+ Based Band-Pass Filter Design for EEG Analysis”, *Firat University Journal of Engineering Sciences*, 34(1): 133-144, (2022).
- [27] Bal Koçyiğit, F., “MMR 672 Building Acoustics Theory Lecture Notes”, <https://moodle.atilim.edu.tr/course/view.php?id=3771>, Accessed date: 27 December 2022
- [28] Stephens, R., “Active filters using current-feedback amplifiers”, *Analog Applications*, (2004).
- [29] Banerjee, A., “Automated Electronic Filter Design”, Springer, (2017).
- [30] Buluklu, H. M., Bal Koçyiğit, F., Köse, E., “Experimental Analysis of Different Materials Produced from Organic Wastes Grown in Turkey and Can Provide High Sound Transmission Loss (Under Review).
- [31] Filter Design and Implementation, [https://www.eecis.udel.edu/~vsaxena/courses/ece697A/docs/Mat lab% 20 Filter% 20Design% 20and% 20Implementation.pdf](https://www.eecis.udel.edu/~vsaxena/courses/ece697A/docs/Mat%20lab%20Filter%20Design%20and%20Implementation.pdf). Accessed date:11 September 2022
- [32] Kaya, T., “Digital filter design with genetic algorithm”, *Firat University, Graduate School of Natural and Applied Sciences, Department of Electrical-Electronics Engineering*, 74, Elazığ, (2006).
- [33] Winder, S., *Analog and digital filter design*, Elsevier, (2002).
- [34] Dela, A., Shtylla, B., de Pillis, L., “Multi-method global sensitivity analysis of mathematical models”, *Journal of Theoretical Biology*, 546, 111159. (2022).
- [35] Kugelstadt, T., “Active filter design techniques, In *Op amps for everyone*”, 365-438, Newnes, (2009).
- [36] Kuhn, K. A., *Sallen-Key Low-pass Filter*, March 9, (rev. Jan. 2, 2016), (2013).
- [37] <https://avesis.erciyes.edu.tr/downloadfile/egunay>. Accessed date: 26 December 2022
- [38] https://www.ktu.edu.tr/dosyalar/ofehm_bb016.pdf. Accessed date: 26 December 2022
- [39] <http://www.ti.com/tool/TINA-TI>. Accessed date: 10 September 2022
- [40] Podder, P., Hasan, M., Islam, M., Sayeed, M., “Design and implementation of Butterworth, Chebyshev-I and elliptic filter for speech signal analysis”, *arXiv preprint arXiv:2002.03130*, (2020).
- [41] *Sallen-Key Low-pass Filter Design Tool (okawa-denshi.jp)*. Accessed date: 10 September 2022

- [42] İmamoğlu, H., Bağdatlı, S. M., “MATLAB Simulink of engineering problems mathematical modeling with the support of the program”, *Soma Vocational School Journal of Technical Sciences*, 1(33): 1-15, (2022).
- [43] <https://devreyakan.com/sallen-key-filtresi-sallen-and-key-filter/>. Accessed date: 28.12.2022
- [44] Yan, X. P., Liu, F. B., Zhang, C. H., “Multiple stability switches and Hopf bifurcation in a damped harmonic oscillator with delayed feedback”, *Nonlinear Dynamics*, 99(3): 2011-2030, (2020).
- [45] Cong, S., James Hu, S. L., Li, H. J., “Model updating methods using complex eigenvalues: sensitivity-based versus cross-model cross-mode”, *Journal of Engineering Mechanics*, 147(4): 04021013, (2021).