



Research Article

Geometrical optimization of city gate station's water bath indirect heater to minimization of fuel consumption

Davood SHAFIEI¹, Seyed Alireza MOSTAFAVI^{2,*}, Saeid Jafari MEHRABADI³

¹Department of Mechanical Engineering, Arak Branch, Islamic Azad University, Arak, 1477893855, Iran

²Department of Mechanical Engineering, Faculty of Engineering, Arak University, Arak, 3848170001, Iran

³Department of Mechanical Engineering, Arak Branch, Islamic Azad University, Arak, 1477893855, Iran

ARTICLE INFO

Article history

Received: 15 July 2021

Revised: 07 December 2021

Accepted: 11 December 2021

Keywords:

Natural gas; Geometrical parameters; Thermal modeling; Water bath indirect heater; Optimized geometry; Fuel consumption

ABSTRACT

Gas industry as one of the greatest sectors of energy, has a major role in environmental issues. A category of energy intensive parts in gas industry is heaters in City Gate Stations which consume colossal volumes of the purified gases. Different optimization strategies to improve the efficiency of these heaters entailing preheating, waste heat recovery of exhausts, insulating pipelines and mounting economizers or recuperators or even using renewable energy sources have been already introduced. Besides, finding the optimized geometry is very essential in improving the efficiency. In this study, a far efficient model for heaters was introduced using the thermal modeling of the process. Based on the properties of the inlet gas, the volume of the gas passing from the CGS and ambient conditions, the consumption of the fuel as well as heater efficiency have been computed as a function of inlet gas properties, CGS's gas flow rate and ambient condition. Then, results were verified by real data taken from Arak CGS station in Iran. The comparison proves the great correlation between the theoretical and experimental results. Findings show that with an increase in the heater length, a reduction in thermal resistance coincides with a higher thermal hysteresis. This causes higher fuel consumption and lower efficiency. Moreover, the higher the length of the fire tube, the more heat is transferred to the pure water and the higher is the efficiency. Considering the optimized heater configuration the efficiency improves two folds; changing from 32% to 71%.

Cite this article as: Shafiei D, Mostafavi SA, Mehrabadi SJ. Geometrical optimization of city gate station's water bath indirect heater to minimization of fuel consumption. J Ther Eng 2023;9(4):841–860.

INTRODUCTION

Sustainable development should supply all human needs without putting the next generations at risk in terms of meeting their needs. Prior to achieving such

sustainability, there should be equity between current and next generations over basic rights such as work, education, health and environment. Unfortunately, after industrialization the environment has been brutally exploited.

*Corresponding author.

*E-mail address: a-mostafavi@araku.ac.ir

This paper was recommended for publication in revised form by Regional Editor Sergey Glazyrin



Such damages to the ecosystem, which gradually revealed their fatal consequences, have pushed the world towards maintaining and preserving the environment. One of the causes of environmental damages is energy waste by those systems working far from their energy-efficient condition. Of many advantages of lower energy use is the great reduction in carbon footprint and easing the climate change. On the contrary to the plethora of efforts on facilitating the application of renewable energies, fossil fuels are still being vastly used because they are cheap and abundant. Increasing population also, puts a strain on energy usage so that has kept increasing in recent years and especially Iran's average energy usage is about 4 folds of the world average. Natural gas is cheap, relatively clean and abundant, with a high thermal value and so it seems the best choice for many cases. Barkhordar et al. [1] stated that high subsidies are the main cause of nonstop growth in energy consumption. Industry sector has contributed to 54% of the total global energy consumption. What is more, it was the cause of 37% of the green gas emission in 1971 which increased to 65% in 2018. In Iran, energy consumption is remarkably higher than the international norms where it has meet an increase of 53% from 1990 to 2015 while at the same time Europe Union could reach a 37% drop in its energy use. Therefore, analyzing the energy resources in Iran and improving their efficiency is of a great importance on the development path. Iran's gas Industry, is a great essence in providing basic needs throughout the country. The policy over gas production is based on two parameters: the export volume and volume consumed consumption within the boarder. Therefore, the projection of the internal consumption of gas is decisive. Abundant gas resources have caused that its contribution in the energy sector becomes as high as 70%. Therefore, an infinitesimal improvement in gas-consuming industry can be a great step to reduce the total energy consumption.

Heaters installed in CGS stations are energy intensive. Giving a total number of 2000 heaters in stations throughout the country it is prudent to think of their efficiency. The beginning point in gas distribution system is the extraction of the gas from gas wells or gas/oil wells. Containing a repertoire of corrosive contents the extracted gas then should be sweetened in gas refineries. Sweetened gas then is distributed all over the country through a network of pipelines. However, considering the long journey of gas flow through pipes and internal frictions the pressure of the gas drops from a standard level and thus there must be some Gas Compressor Stations along the way before the gas will be used by the final users [2].

City Gate Gas Pressure Reducing Station

Natural gas generally is received to the main nodes near the big cities or industries with pressures as high as 700-1000 psi which should be remarkably reduced before being used. This pressure reduction occurs to the low of 250 psi in City Gate Stations (CGSs). The main equipment installed

in a CGS include filters, heaters, general valves, shut-off valves, regulators, safety valves, odorizers and meters.

Since, lowering the pressure naturally causes a temperature reduction, which can cause hydration in gas as well as freezing the regulator and cutting the gas flow, it is customary that prior to pressure reduction gas flow is heated to a certain point. This is done by water bath indirect heaters which have bisectonal shells. In the lower section of the shell fire tube is located which heats the distilled water is located. By the use of hot water bath the flow of the gas which is in the Gas Tube is heated. The combustion byproducts are thrown away from the exhaust while required air flow for combustion is sucked into the heater. For the sake of controlling the level of the distilled water in the heater there is an Expansion Tank at the top of the heater.

Convection is the heat transfer mechanism in the water bath indirect heater. This means that the gas is burned in the flares and the heat in the fire tube is transferred to the distilled water. This heat is then transferred to the gas flow in the Gas Tube. Measuring temperature and pressure are included in the inner and outer ports of the heater. The heat production by the flares depends on the ambient temperature and gas flow volume from the station and from the heater. Tuning the flare is piloted by the temperature of the gas flow at the exit of the heater. The efficiency of the water bath indirect heaters is quite low and considering their prevalence they impel an intolerably adverse burden upon the environment.

Different approaches have been already taken to increase the efficiency of such heaters including preheating, waste heat recovery of the stocks, insulating pipelines and mounting economizers or recuperator or even using renewable energy sources.

Saadat et al. [3] worked on the modeling and multi-objective optimization of a CGS with organic Rankine flash cycle. Analyzing exergy parameters showed that the 91.78% of relative exergy destruction would occur in the flares and heater. Their optimized system also yielded 8.75% increase in thermal efficiency of the system and a reduction of 337.62 kW in exergy loss. Rahmati et al. [4] investigated the application of the multi-walled carbon nanotubes in Ethylene Glycol/water-based fluid in CGS indirect heaters. Rastegar et al. [5] achieved a novel way to supply distilled water for such baths in CGSs. The produced volume of the distilled water was examined with three different depths of the water and it was concluded that more distilled water would be attained in the shallower depth. Gunes et al. [6] added a coiled wire insert inside the fire tube and claimed that it would reduce the energy consumption in the heater. The results showed that Nusselt number and friction increased with the ratio of pitch and distance of the coil. Ashuri et al. [7] studying Bisetun CGS, computed the Joule-Thomson coefficient and suggested lowering the gas temperature in the regulator by which a remarkable energy could be saved. Azizi et al. [8] concentrated on the heat loss from the exhaust of the heater installed at Mahshahr CGS.

They suggested to use this heat waste in a shell and tube heat exchanger for pre-heating the natural gas.

Khalili et al. [9] studied thermal efficiency and heat loss in Shahrekord CGS heater and recommended to improve the flares, reduce the extra air volume entering the heater and increase the heat transfer surface in order to minimize heat loss from the exhaust. Saber Moghadam et al. [10] used computational fluid dynamics aiming at optimizing heat energy consumption for a CGS located in Mashhad city. They found that specifying the proper location for the pump can be crucial in making the thermal energy distributed uniformly over different surfaces of the heater causing efficiency improvement. Hossein et al. [11] studied the possibility of improving the heat transfer by using twisted tape and coiled wire insert inside the gas tube. Wu et al. [12] used the application of the Alumina nanofluids with 5 different weight concentrations in the bath to investigate the behavior of heat transfer. Sedighi Dizaji [13] studied the exergy of the shell and tube exchangers. They observed that increasing flow rate, inner temperature and coil diameter increases the exergy loss in such exchangers. Farzanegard et al. [14] analyzing the energy and exergy in CGSs introduced the utilization of the solar energy system to optimize energy consumption in CGSs. Rashidmardani et al. [15] reported that pre-heating and reusing the heat of the combustion products as a great step in heat recovery and improving the thermal efficiency. Ghaebi et al. [16] analyzed the energy, exergy, economy and environment nexus of heaters for the concurrent production of the electricity and hydrogen.

In every thermal system the geometry has a decisive role in thermal loss, heat absorption and thermal efficiency. Therefore, along with all other efforts, finding an optimum geometry would increase the efficiency. In this study, a new model with a higher efficiency will be introduced. The

cubic geometries give chance to better positioning of the internal parts of the heater in a neat way. Increasing number of gas tube passes in the heater, increasing its length, is very effective in increasing heat transferred to the gas. Moreover, the geometry of the heater has a say in how heat is received and transferred and the distribution of the temperature in heater which will be focused in this study.

In this paper, a heater was thermally modeled and based on the burning gas flow rate of the heater, gas flow rate of the station and the ambient condition, fuel consumption and thermal efficiency were calculated and results were verified against operational data of Arak CG station. Then it was tried to change the model to achieve more appropriate geometries. Finally specifying influential geometrical parameters genetic algorithm was used to obtain the optimum geometry.

MODELING

Heat Transfer System of CGSs

Since Joule-Thomson coefficient has a positive value in the natural gas, within the CGS when gas passes from the regulator, its temperature drops. Therefore, portion of the gas exiting the station must be burnt in the heater to warm the gas stream. This taken-up gas is generally is mixed with air and then burnt in atmospheric flares and enter the fire tube. Surrounding the pipes of the fire tube, the distilled water becomes heated and this energy is then transferred to the gas flowing in the Gas Tube thank to the relatively long contact time between the cold and hot fluids. The heated gas then will pass the regulator where its pressure drops considerably. The safety is the main reason to use indirect heat transfer in CGS. The main parts of such a heart are illustrated in Figure 1.

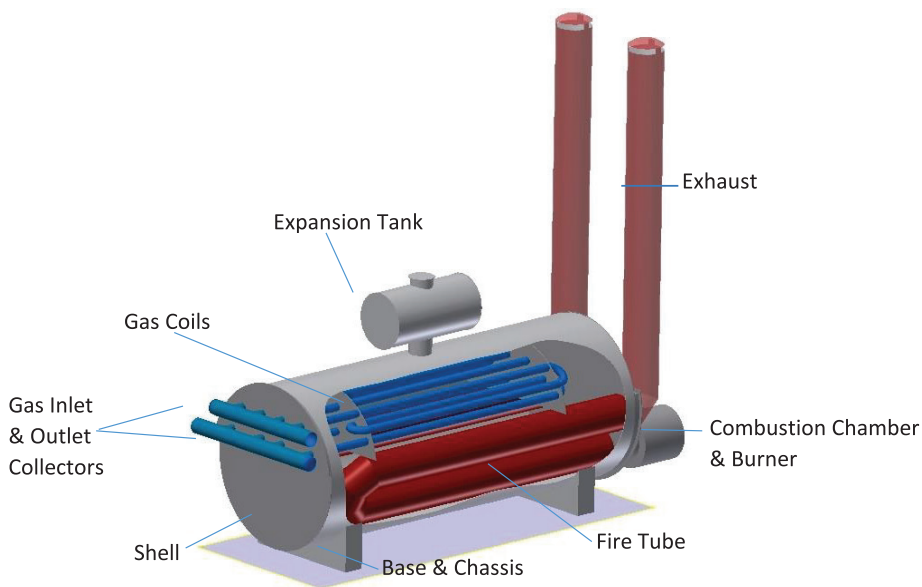

Figure 1. Heater and its parts.

Figure 2 depicts a common cylindrical heater used in gas industries where the number of passes of the gas tube and their configuration are specified. In such a design, it is not possible to add more passes of the gas tube and therefore, portion of the space of the heater is not effectively utilized.

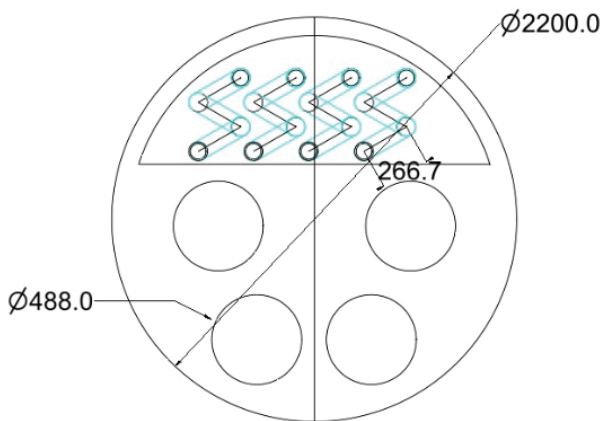

Figure 2. The configuration and positioning of the gas tubes in cylindrical heaters.

Yet, as can be seen in figure 3, using cubic geometry instead of cylindrical one would provide a better chance to position the gas tubes which means a higher surface to receive and transfer heat between cold and heat fluids in the heater. However, with bigger area available, there is a higher risk for heat loss and therefore both conflicting effects should be considered for the optimization of the heater and the net effect would dictate the efficiency.

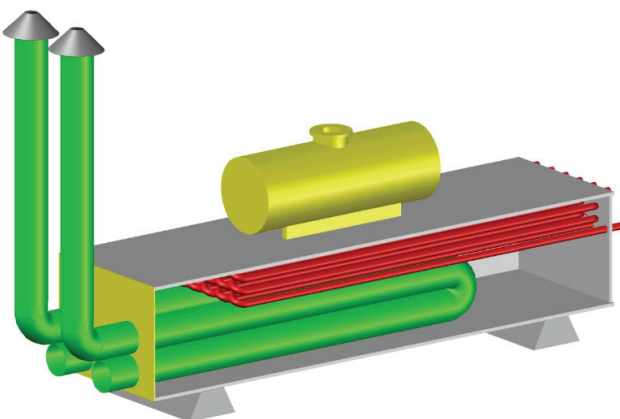

Figure 3. Cubic heater.

In Figure 4, the side view of the cubic heater is depicted which shows number of passes of the gas tube and their positions. As it is clear this geometry provides the possibility of positioning more gas tubes.

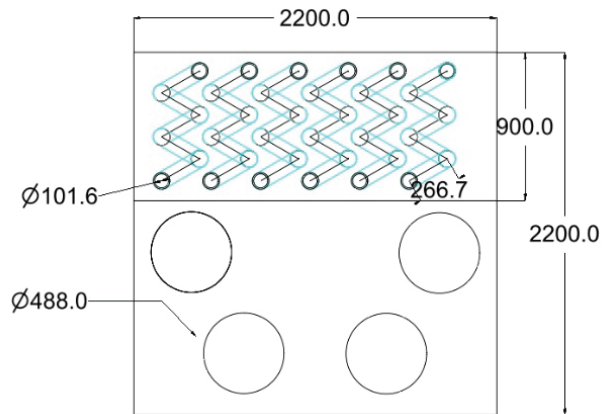

Figure 4. The positioning of the gas tubes in cubic heaters.

Combustion Energy

Using thermodynamics, heat transfer and fluid mechanics a thermal model of the heaters in CGS can be built. Such heaters in CGSs act as triple flow heat exchangers. Due to high flow rates in gas tubes, their size is usually gigantic. For accurate computation of the heater efficiency and its fuel consumption, the clear thermochemical properties of the natural gas mixture as well as exact geometry of the heater are needed. The heating of the gas is provided by the burning of portion of its flow in the fire tube of the heater. Equation (1) shows the total combustion energy of the burnt gas mixture in fire tube using mass and energy conservation principles.

$$\dot{Q}_{fuel} = \dot{Q}_{loss} + \dot{Q}_{Gas} = \dot{Q}_{Gas} + \dot{Q}_{lost} + \dot{Q}_{smoke} \quad (1)$$

Where \dot{Q}_{lost} is the heat loss from the surface in $\frac{kJ}{s}$, \dot{Q}_{smoke} is heat loss from the exhaust in $\frac{kJ}{s}$ and \dot{Q}_{Gas} is the heat fraction received by the main stream gas flow passing the gas tube in $\frac{kJ}{s}$.

Absorbed heat by heat coils

The flow of gas through the long passes of the gas tube facilitates heat transfer from the hot water to the cold gas. Figure 5 shows the section of the gas tubes in the heater.

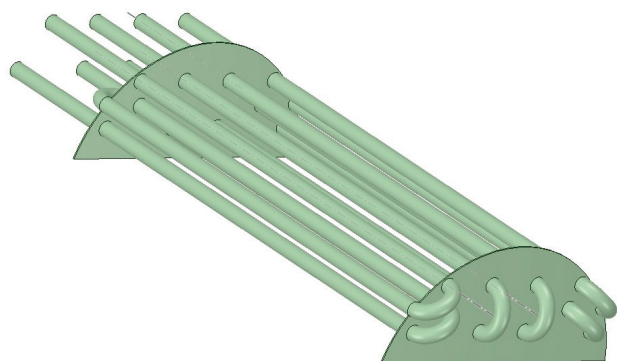

Figure 5. Gas tubes in the heater.

\dot{Q}_{Gas} which is the amount of the heat absorbed by the gas in the gas tube can be computed using equation (2).

$$\dot{Q}_{Gas} = \dot{m}_{Gas}(h_{out} - h_{in}) = \dot{m}_{Gas} \int_{Gas\ i}^{Gas\ o} C_{p\ Gas} dT \quad (2)$$

Due to the difference in gas flow temperature from when it enters to the heater to when it exits from the heater and considering the dependence of the specific heat C_p to the temperature, equation (2) can be rewritten as presented in equation (3).

$$\dot{Q}_{Gsa} = \dot{m}_{Gas}(h_{out} - h_{in}) = \dot{m}_{Gas}(C_{p,mix,out}T_{Gas\ o} - C_{p,mix,in}T_{Gas\ i}) \quad (3)$$

To obtain the mass flow rate of the gas passing the pass coils in $\frac{m^3}{s}$ the flow meter installed at CGS can be used, though the exact density of the gas mixture also should be known.

$$\dot{m}_{Gas} = \rho_{Gas}\dot{V}_{Gas} \quad (4)$$

Considering the temperature difference in gas entering the heater and exiting it, below equation can be used to compute specific heat value C_p for different components of the gas mixture.

$$\overline{C_p} = a + bT + cT^2 + dT^3 \quad (5)$$

Where T is temperature in K and a, b, c, d are equation coefficients which are unique for each component of the mixture. In this study natural gas is considered as a mixture with 21 components. After specifying the specific heat C_p for each part of the compound, C_p for the mixture can be computed using below equation:

$$C_{p\ mix\ Gas} = \sum_{i=1}^{21} \frac{X_i \overline{C_{p,i}}}{M_i} \quad (6)$$

$$X_i = \frac{Y_i M_i}{M_{mix}} \quad (7)$$

$$M_{mix\ Gas} = \sum_{i=1}^{21} Y_i M_i \quad (8)$$

In addition to the high dependency of the gas temperature at the heater entrance to the ambient temperature, the gas temperature also depends on the distance of the CGS to the previous pressurizing station, the upper stream consumption rate and pressure drop of line. Therefore, gas inlet temperature is considered as the input of the model to better picture its effect on fuel consumption and heater efficiency. Selection of the gas temperature exiting from the

heater is crucial as it should be high enough avoiding the formation of hydrates when gas passes through the regulator. This value, as a known parameter, is also considered as an input parameter of the model.

Energy loss from the side surfaces

Part of the combustion energy is wasted through the side and body surfaces of the heater. In the internal volume of the heater, gas tubes, water tubes are located and the remaining volume is filled with distilled water. Boundaries, from inside toward the outside of the heater surface, are made of layers of steel, glass wool and aluminum in order to provide thermal insulation for the heater. Thus, produced heat in the fire tube, is consumed first to warm the water and then the gas in the gas tube.

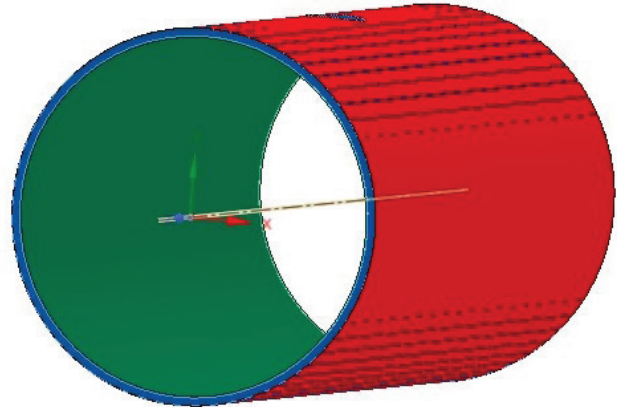

Figure 6. Schematic of the outer surface of the heater.

Notwithstanding, minor portion of the heat would find its way out from the external surfaces of the heater.

This heat loss \dot{Q}_{lost} can be defined using equation (9) according to the thermal resistance between combustion products and the ambience illustrated in Figure 7.

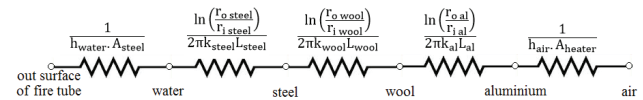

Figure 7. Thermal resistance between combustion products and ambience around the heater.

$$\dot{Q}_{lost} = \frac{T_w - T_{am}}{\frac{\ln(r_o\ steel)}{2\pi k_{steel} L_{steel}} + \frac{\ln(r_o\ wool)}{2\pi k_{wool} L_{wool}} + \frac{\ln(r_o\ al)}{2\pi k_{al} L_{al}} + \frac{1}{h_{air} A_{heater}} + \frac{1}{h_{water} A_{steel}}} \quad (9)$$

$$A_{steel} = 2\pi r_{i\ steel} L_{steel} + 2\pi r_{i\ steel}^2 \quad (10)$$

$$A_{\text{heater}} = 2\pi r_{i,al} L_{al} + 2\pi r_{i,al}^2 \quad (11)$$

It is worth mentioning that, considering a cubic shape for the heater:

$$\dot{Q}_{\text{lost}} = \frac{T_w - T_{\text{am}}}{\frac{t_{\text{steel}}}{k_{\text{steel}} A_{\text{steel}}} + \frac{t_{\text{wool}}}{k_{\text{wool}} A_{\text{wool}}} + \frac{t_{al}}{k_{al} A_{al}} + \frac{1}{h_{\text{air}} A_{\text{heater}}} + \frac{1}{h_{\text{water}} A_{\text{steel}}}} \quad (12)$$

$$A_{\text{steel}} = 2(a_{\text{steel}} + b_{\text{steel}} - 4t_{\text{steel}})L_{\text{steel}} + 2(a_{\text{steel}} - 2t_{\text{steel}})(b_{\text{steel}} - 2t_{\text{steel}}) \quad (13)$$

$$A_{\text{heater}} = 2(a_{al} + b_{al})L_{al} + 2a_{al}b_{al} \quad (14)$$

the water temperature is effective on the heat loss from the surfaces. However, it is possible to compute this temperature according to equation (15) knowing the gas temperature at the entrance and exit of the heater.

$$T_w = \frac{T_{\text{Gas},o} - T_{\text{Gas},i}}{1 - \exp\left(-\frac{1}{\dot{m}_{\text{Gas}} c_p \text{Gas} R_{\text{totgas}}}\right)} \quad (15)$$

According to equation (8), thermal resistance between hot distilled water and cold gas inside the gas tube can be computed, using equation (16).

$$R_{\text{totgas}} = \frac{1}{h_{\text{gas}} A_{i \text{ coil}}} + \frac{\ln\left(\frac{r_{o \text{ coil}}}{r_{i \text{ coil}}}\right)}{2\pi k_{\text{coil}} L_{\text{coil}}} + \frac{1}{h_{\text{water}} A_{o \text{ coil}}} \quad (16)$$

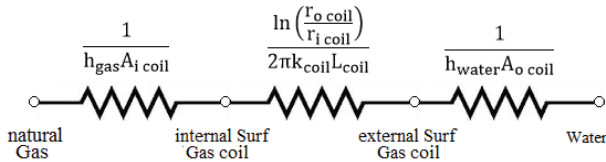

Figure 8. Total thermal resistance between water and natural gas.

Convectivity coefficient of natural gas h_{coil} and Reynolds number of gas tube's flow can be computed using equation (17).

$$Re_{D,\text{Gas}} = \frac{4\dot{m}_{\text{Gas}}}{\pi D_{\text{coil}} \mu_{\text{Gas}}} \quad (17)$$

$$\left\{ \begin{array}{ll} Nu_{D,\text{Gas}} = \frac{h_{\text{gas}} D_{\text{coil}}}{K_{\text{Gas}}} = 0.023 Re_{D,\text{Gas}}^{4/5} Pr_{\text{Gas}}^n & \text{if } T_{\text{surf}} \leq T_{\text{Gas},o} \quad n = 0.3 \\ & \text{if } T_{\text{surf}} \geq T_{\text{Gas},o} \quad n = 0.4 \end{array} \right. \quad (18)$$

Exhaust heat loss

Apart from the heat shares including \dot{Q}_{Gas} used for warming gas flow in gas tube and \dot{Q}_{lost} lost through the surface, a third share of the heat \dot{Q}_{smoke} is lost through the exhaust which can be computed using equation (19).

$$\dot{Q}_{\text{exhaust}} = \dot{m}_{\text{exhaust}}(h_{\text{in exhaust}} - h_{\text{out exhaust}}) = \dot{m}_{\text{exhaust}}(c_{p \text{ exhaust},i} T_{\text{exhaust},i} - c_{p \text{ exhaust},o} T_{\text{am}}) \quad (19)$$

The specific heat for the smoke with five different components $C_{p \text{ smoke},o}$ can be computed at initial temperature $T_{\text{smoke},i}$ as defined by $C_{p \text{ smoke},i}$ and at exiting temperature T_{am} using equations and meanwhile the flow rate of the smoke mixture can be computed using equation (20).

$$\dot{m}_{\text{exhaust}} = \dot{m}_{\text{air}} + \dot{m}_{\text{fuel}} = \dot{m}_{\text{fuel}} \left(1 + \frac{\dot{m}_{\text{air}}}{\dot{m}_{\text{fuel}}}\right) \quad (20)$$

$\frac{\dot{m}_{\text{air}}}{\dot{m}_{\text{fuel}}}$ defines the ratio of the air sucked in the heater for combustion to the fuel burnt in the heater. This ratio can be computed using the conservation of the mass and knowing the molar mass of the fuel mixture. In order to compute the heat being lost from the exhaust the value of the smoke temperature at the entrance of the exhaust $T_{\text{smoke},i}$ should be known. This temperature can be computed using the heat transfer formulation of the surface constant temperature and knowing the thermal resistance between the smoke and the water using equations (21) and (22).

$$\frac{\Delta T_o}{\Delta T_i} = \frac{T_{\text{exhaust},i} - T_w}{T_{\text{combustion}} - T_w} = \exp\left(-\frac{1}{\dot{m}_{\text{exhaust}} c_{p \text{ ave.exhaust}} R_{\text{totexhaust}}}\right) \quad (21)$$

$$T_{\text{exhaust},i} = T_w - \frac{T_{\text{combustion}} - T_w}{1 - \exp\left(-\frac{1}{\dot{m}_{\text{fuel}} \left(1 + \frac{\dot{m}_{\text{air}}}{\dot{m}_{\text{fuel}}}\right) c_{p \text{ ave.exhaust}} R_{\text{totexhaust}}}\right)} \quad (22)$$

Where R_{totsmoke} is the total thermal resistance between smoke and water which can be computed, according to Figure 9, using equation (23).

$$R_{\text{totexhaust}} = \frac{1}{h_{\text{exhaust}} A_{i \text{ stack}}} + \frac{\ln\left(\frac{r_{o \text{ stack}}}{r_{i \text{ stack}}}\right)}{2\pi k_{\text{stack}} L_{\text{stack}}} + \frac{1}{h_{\text{water}} A_{o \text{ stack}}} \quad (23)$$

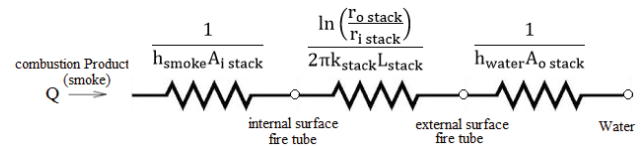

Figure 9. Total thermal resistance between water and smoke.

In order to compute convection heat transfer coefficient of smoke mixture, h_{stack} , the corresponding formulation can be utilized resulting in equation (24).

$$h_{\text{stack}} = \frac{0.023 Re_{D,\text{exhaust}}^{4/5} Pr_{\text{exhaust}}^n K_{\text{exhaust}}}{D_{\text{stack}}} \quad (24)$$

Though, it should be noted that according to assumed cubic geometry of the heater, as depicted in Figure 10, some

changes in formulations become necessary as presented in equations (25) and (26).

$$R_{\text{tot,exhaust}} = \frac{1}{h_{\text{exhaust}}A_{i\text{ stack}}} + \frac{t_{\text{stack}}}{k_{\text{stack}}A_{i\text{ stack}}} + \frac{1}{h_{\text{water}}A_{o\text{ stack}}} \quad (25)$$

$$h_{\text{stack}} = \frac{0.023Re_{a,\text{exhaust}}^{4/5}Pr_{\text{exhaust}}^n K_{\text{exhaust}}}{a_{\text{stack}}} \quad (26)$$

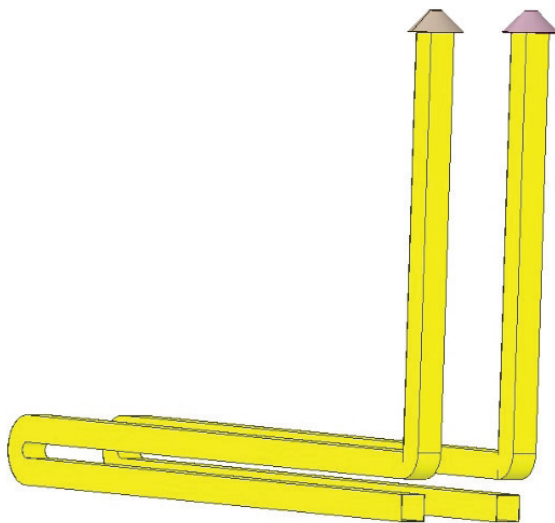

Figure 10. Exhaust geometry with cubic shape.

Finally, fuel consumption and efficiency can be presented by equations (27) and (28).

$$\dot{m}_{\text{fuel}} = \frac{\dot{Q}_{\text{lost}} + \dot{Q}_{\text{Gas}}}{\eta_{\text{combustion}} \text{LHV} - \dot{Q}_{\text{smoke}}} \quad (27)$$

$$\eta_{\text{heater}} = \frac{\dot{Q}_{\text{Gas}}}{\dot{m}_{\text{fuel}}\text{LHV}} \quad (28)$$

Presented formulations were integrated in a computer code which is able to compute outputs namely fuel consumption and efficiency of the heater based on gas properties entering and exiting the gas tube for the water bath indirect heaters.

RESULTS AND DISCUSSION

After establishing heater’s thermal model, the first step is to validate its performance using real processing data. The reference was Arak CGS unit with the capacity of 60000 SCMH for which all specifications including dimensions were considered using the documents at National Iranian Gas Company. The studied heater, in addition to temperature and pressure sensors, has a flow meter to measure gas flow rate. The gas which has passed through gas tubes is also measured with a flow meter at the exit of the heater. All of the physical and thermodynamic properties were carefully probed and the composition of the natural gas mixture in the CGS was accurately measured. Putting all data into the code, the outputs of the code namely fuel consumption and thermal efficiency are listed and compared with measured values in Table 1.

As can be seen from Table 1, the analytical error of the developed code, in comparison with real data, was as low as 6.1%.

For more comprehensive validation, this comparison was made at other three different working conditions when the CGS worked at 50%, 33% and 25% of its capacity and results are presented in tables 2, 3 and 4 respectively. As can be seen the discrepancy was at the low of 8.4%, 5.7% and 7.2% when the station was working at its 50%, 33% and 25% capacity respectively.

Table 1. Comparison between measured and computed data for Arak CGS heater

Item	Computed Data	Measured Values	Unit
Efficiency	31.92	29.97	%
Fuel Consumption	1.4866	1.5832	[kg/s]

Table 2. Comparison between measured and computed data for Arak CGS heater (when the CGS worked at 50% of its capacity)

Item	Computed Data	Measured Values	Unit
Efficiency	31.50	28.85	%
Fuel Consumption	0.7058	0.7705	[kg/s]

Table 3. Comparison between measured and computed data for Arak CGS heater (when the CGS worked at 33% of its capacity)

Item	Computed Data	Measured Values	Unit
Efficiency	29.65	27.96	%
Fuel Consumption	0.5334	0.5656	[kg/s]

Table 4. Comparison between measured and computed data for Arak CGS heater (when the CGS worked at 25% of its capacity)

Item	Computed Data	Measured Values	Unit
Efficiency	27.65	25.66	%
Fuel Consumption	0.4288	0.4620	[kg/s]

The average error of the developed model was kept as low as 6.85% which shows an acceptable performance and proves the reliability of the model for further investigations.

Analysis on Different Geometries of the Heater

In the next step, 6 different geometrical models were considered and analyzed to shed light on how the fuel consumption and efficiency would alter.

Model (1) is the control model- physically presented in Arak CGS- which is illustrated in Figure 11. As can be seen the cylindrical shell of the heater is 8 meter long where the heat is transferred by the two flares and two passes of fire tube, to the four passes of gas tubes.

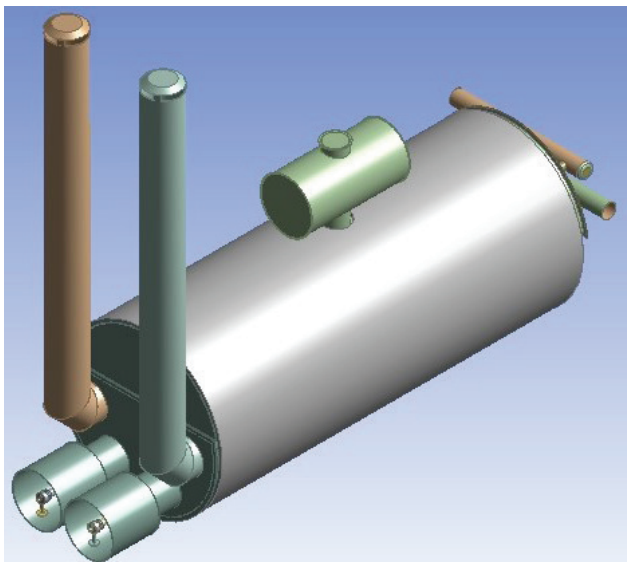

Figure 11. cylindrical heater installed at Arak CGS with capacity of 60000 SCMH.

Model (2) is similar to model (1) in all details albeit the overall geometry in model (2) is cubic. The required modification of code pertained to this difference was made.

Model (3) is analogous to Model (2) with similar external dimensions. However, since cubic shape provides better positioning of the internal parts, six passes of gas tube and four passes of fire tube were positioned for this model.

Model (4): According to Figure 12, in this model in addition to the overall shape of the heater, the geometry of the fire tube is cubic.

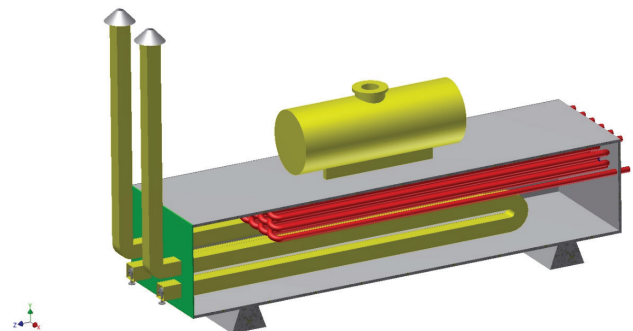

Figure 12. Heater with cubic shell and fire tube.

Model (5): Has a rectangular cubic shell while four passes of cylindrical fire tube was considered.

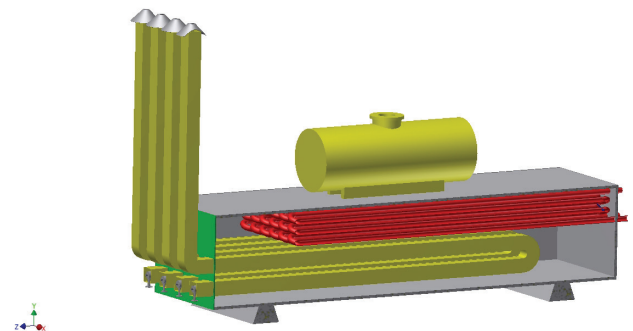

Figure 13. Rectangular cubic heater with 4-passed cubic fire tube.

Table 5. Fuel consumption and efficiency of different heater models

Results/Model	Efficiency	Fuel Consumption(kg/s)
Model (1)	0.3192	1.4866
Model (2)	0.2959	1.6039
Model (3)	0.3786	1.2534
Model (4)	0.5650	0.8398
Model (5)	0.6304	0.7527
Model (6)	0.7122	0.6663

Model (6): According to Figure 13, this model has a rectangular shape and four passes of cubic fire tube design.

Comparison between different models

With constant process parameters, the efficiency and fuel consumption of different models are listed in Table 5.

Figures 14 and 15 also illustratively compare different models, in terms of efficiency and fuel consumption respectively.

Overall, results prove that mere alteration of shell geometry to a cube not only does not improve the efficiency but

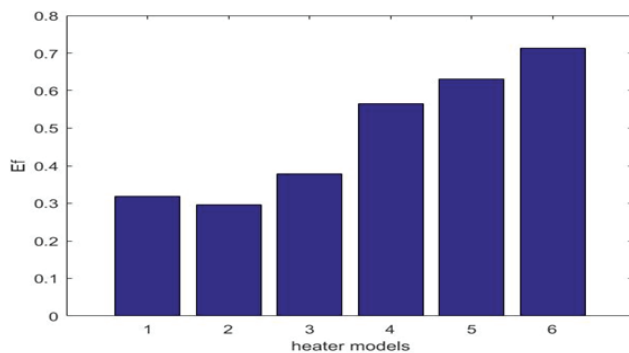

Figure 14. Comparison of efficiency in different models.

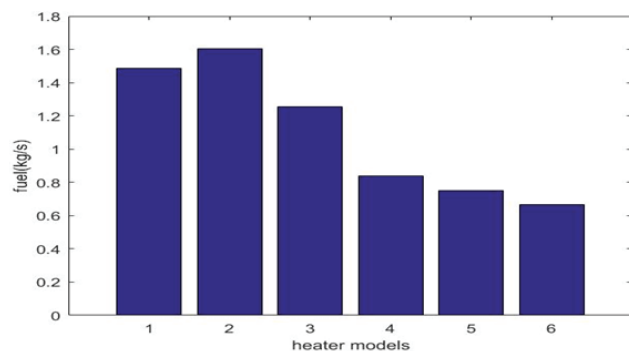

Figure 15. Comparison of fuel consumption in different models.

it decreases it. However, if the extra possibilities of the cubic geometries are used wisely with regard to better positioning of the gas and fire tube, then the efficiency exponentially improves which otherwise would not be possible in cylindrical shapes. Therefore, better performance of the cubic heaters is attributed to the more optimized state of the gas and fire tubes. This performance improvement is due to two reasons: First, increasing the length of the gas coil causes more durability of the gas flow in the heated fluid, And the second reason is that the cubic geometry of the fire tubes increases their heat transfer level with fluids. Obviously, model (6) displayed the superior performance with lower fuel consumption and higher efficiency.

The Effect of Each Geometrical Parameters in Different Models

After performing a general comparison among different models when all parameters were kept constant, now in every model the effect of each of the geometrical variables will be analyzed. This would be a great step towards discovering the optimized geometry.

The effect of fire tube diameter

Looking at already presented formulations and consuming a constant ratio of $\frac{\dot{m}_{air}}{\dot{m}_{fuel}}$, according to equation (17) increasing fire tube diameter would cause a drop in Reynolds Number. Based on equation (18) the lower Reynolds number of the smoke is, the smaller the Nusselt number of the smoke which consequently leads to a lower convection heat transfer coefficient of the smoke. Therefore, water receiving less heat than before has a lower temperature, while smoke losing less heat has higher temperature which in turn increases the exhaust’s heat loss \dot{Q}_{smoke} . Hence, According to equations (27) and (28) fuel consumption increases and efficiency decreases. Overall, with fire tube diameter, in all models, fuel consumption raised and efficiency dropped. This issue is shown in figures 16 and 17 where it can be observed following the general trend, model (6) experienced the lowest reduction in efficiency and a slight increase in fuel consumption and therefore it is the optimum model with regard to the fire tube diameter.

The effect of gas tube diameter

Figure 18 and 19 shows the effect of gas tube diameter on heater efficiency and fuel consumption respectively. Since increasing gas tube diameter is almost neutral on the heat losses and considering the fact that these losses have a decisive role in efficiency and fuel consumption, it can be observed that with variation in gas tube diameter, in all models, the efficiency and fuel consumption remained almost constant.

The effect of tube gas length

Looking at analytical formulations, based on equation (16) it is observable that with lengthening the gas tube, the thermal resistance of the gas tube decreases and heat transfer increases between hot distilled water and cold gas

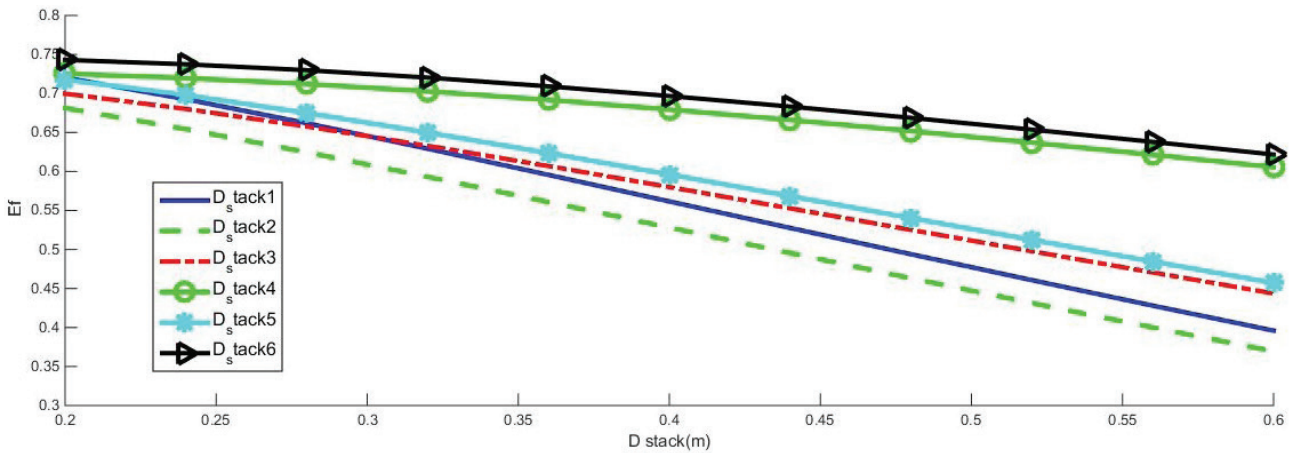

Figure 16. The effect of fire tube diameter on heater efficiency.

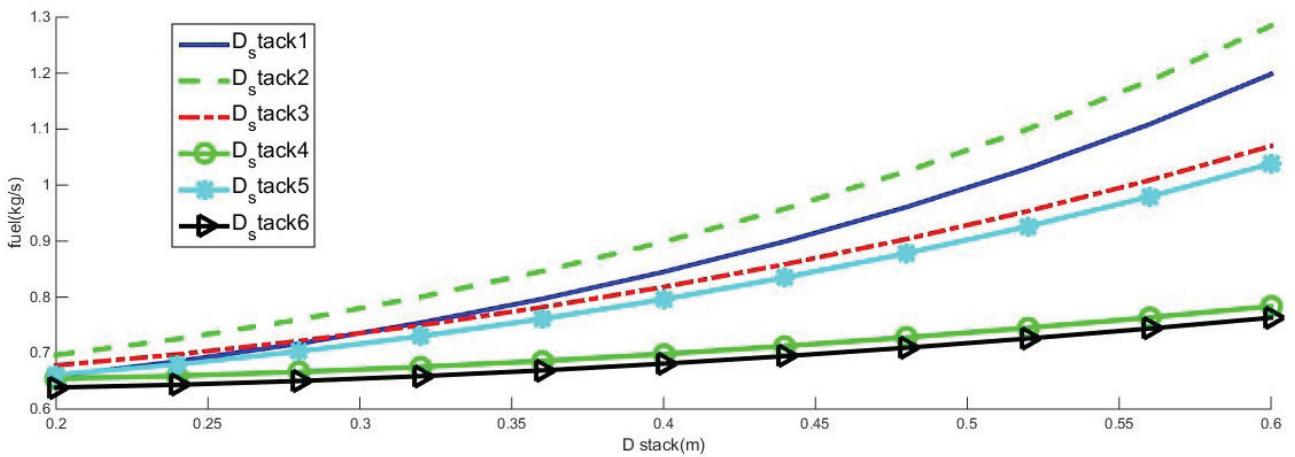

Figure 17. The effect of fire tube diameter on fuel consumption.

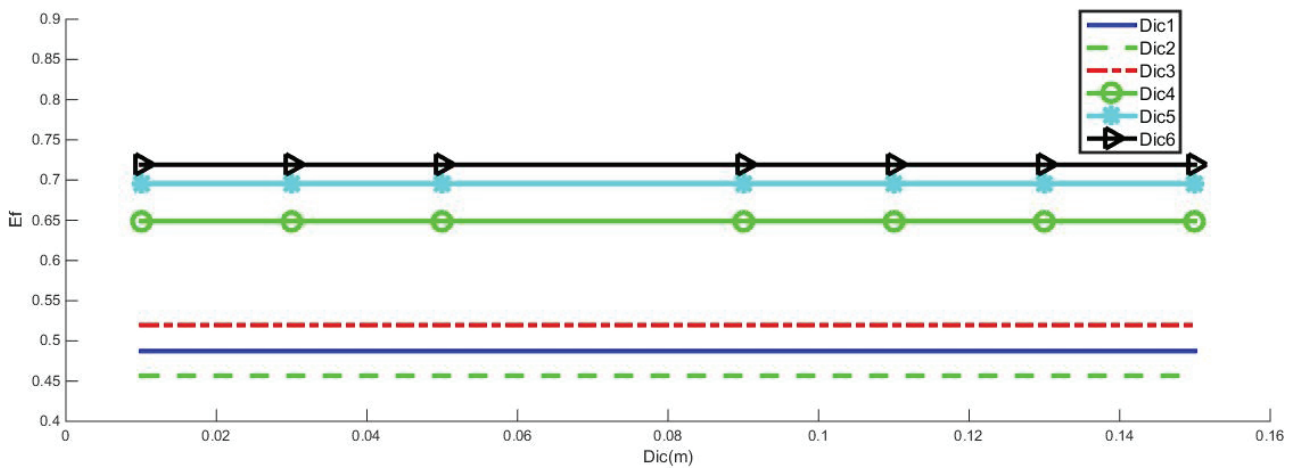

Figure 18. The effect of gas tube diameter on heater efficiency.

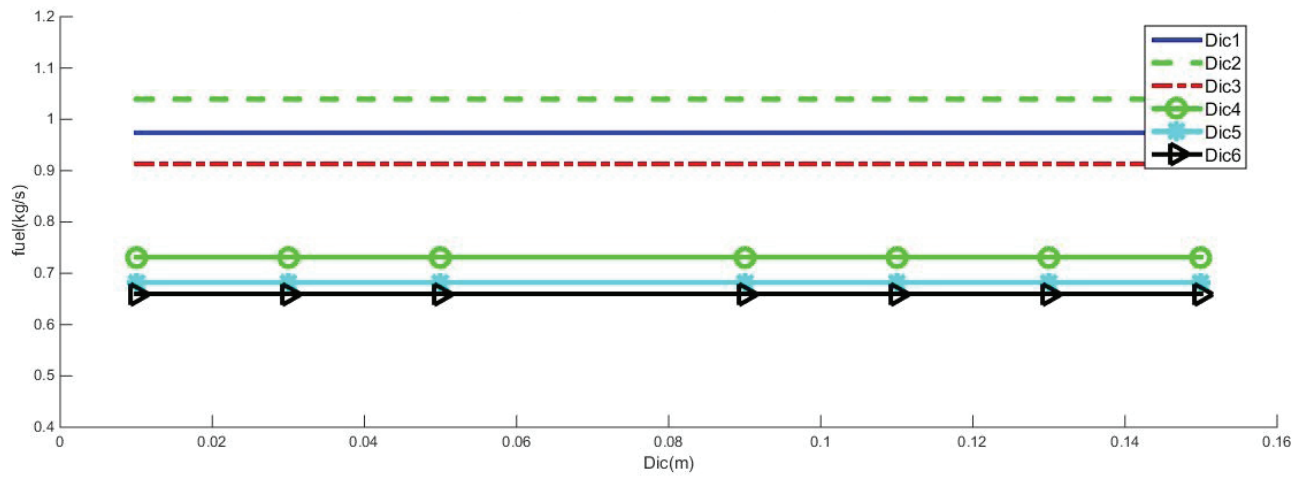

Figure 19. The effect of gas tube diameter on fuel consumption.

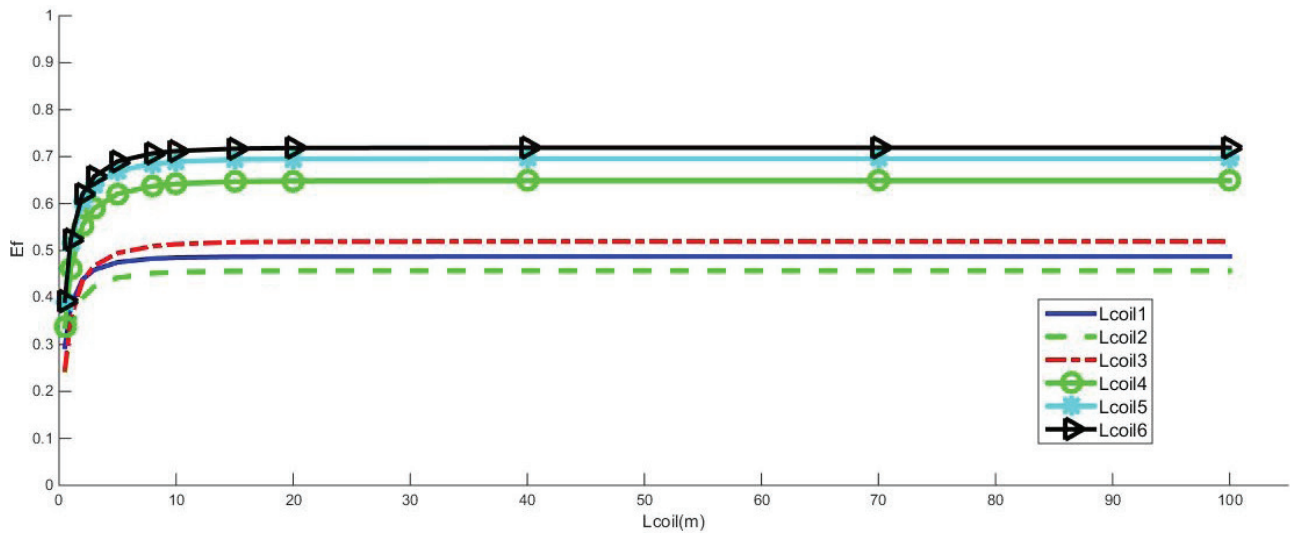

Figure 20. The effect of gas tube length on heater efficiency.

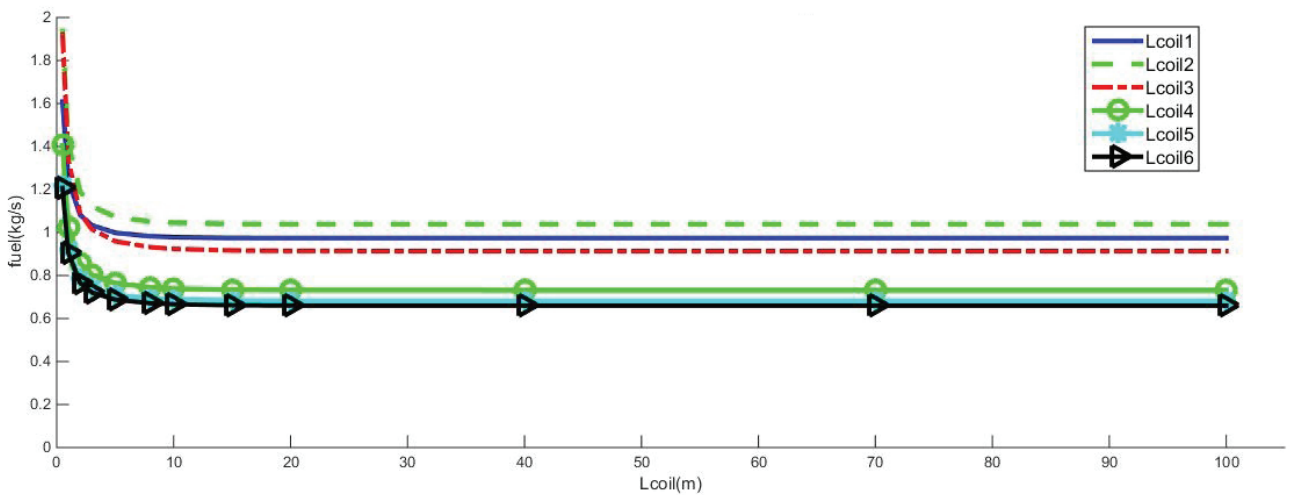

Figure 21. The effect of gas tube length on fuel consumption in the heater.

flow. This would culminate in an improvement in efficiency and fuel consumption for all models. Figures 20 and 21 illustrate that in all models, increasing gas tube length, in a certain range would fairly improves the performance of the heaters while further lengthening the gas tube does not affect the performance. Finally model (6) has shown a better response with regard to the effect of the gas tube length on efficiency and fuel consumption.

The effect of heater length

According to equation (9) increasing heater length, would decrease the thermal resistance in terms of heat loss from the surface which causes more heat waste. This will

aggravate the performance of the heater with higher fuel consumption and lower efficiency according to equations (27) and (28). Figures 22 and 23 show that in all models increasing heater length would have an adverse effect though for model (6), this effect was less severe.

The effect of fire tube length

According to equation (23) increasing the fire tube length reduces the thermal resistance of the fire tube surface which improves heat transfer from fire tube to the distilled water and lowers the exhaust heat loss. This would facilitate the desired performance of the heater according to equations (27) and (28). This analysis can be better seen

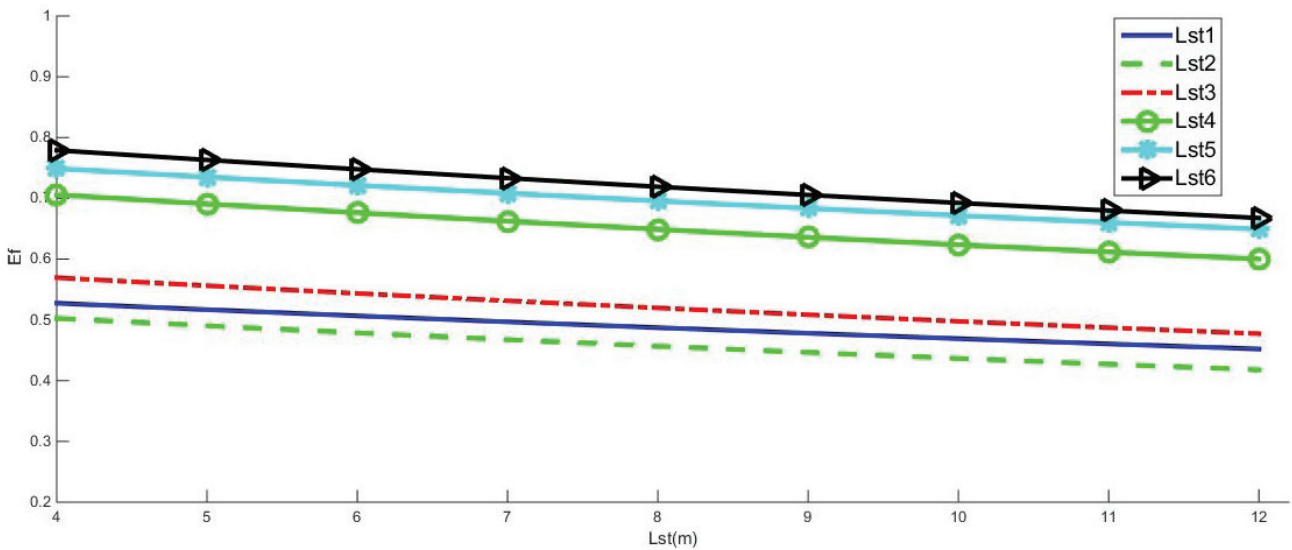

Figure 22. The effect of heater length on efficiency.

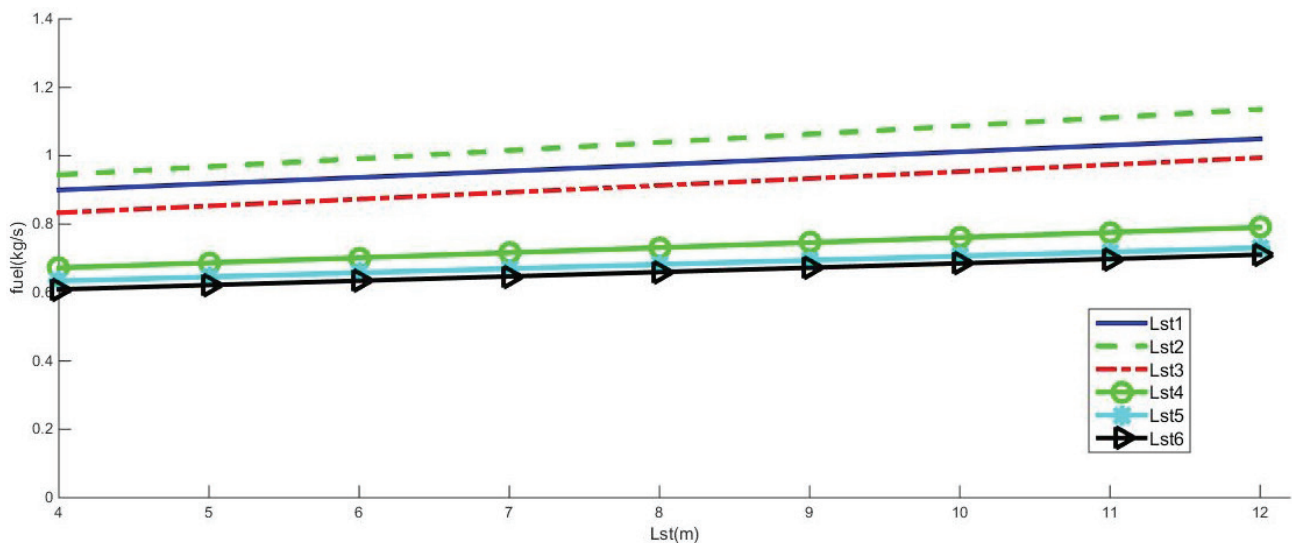

Figure 23. The effect of heater length on fuel consumption.

in Figures 24 and 25 when in all models with increasing fire tube length raises the heater efficiency and lowers the fuel consumption. Though, there is a specific region, in which changing fire tube length is very influential while out of that region the variation in fire tube length becomes nearly ineffective. Model (6) have the highest positive sensitivity with changing fire tube length and therefore shows a superior performance than other models.

The effect of fire tube number of passes

Generally, with increasing the number of passes, the total length of the fire tube will be increased. However, here, it was assumed that fire tube length is constant. In this state,

with increasing number of passes, each pass will be shorter and the exhaust heat loss will increase which in turn, based on equations 27 and 28, lowers the efficiency and increases the fuel consumption. such analysis is confirmed by Figures 26 and 27 which illustrate heater efficiency and fuel consumption with changing fire tube number of passes for all models. Model 6, shows a better performance in comparison with other models.

The effect of heater width

According to equation (9) increasing the width of heater would reduce the thermal resistance leading to a higher heat loss from heater surface and aggregating heater

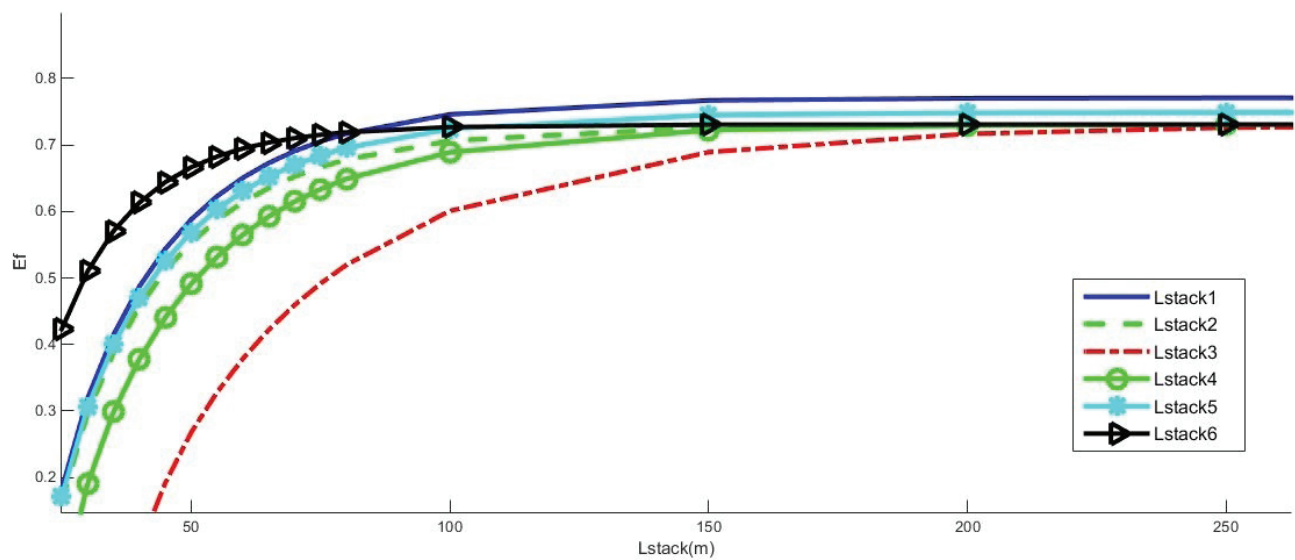

Figure 24. The effect of fire tube length on heater efficiency.

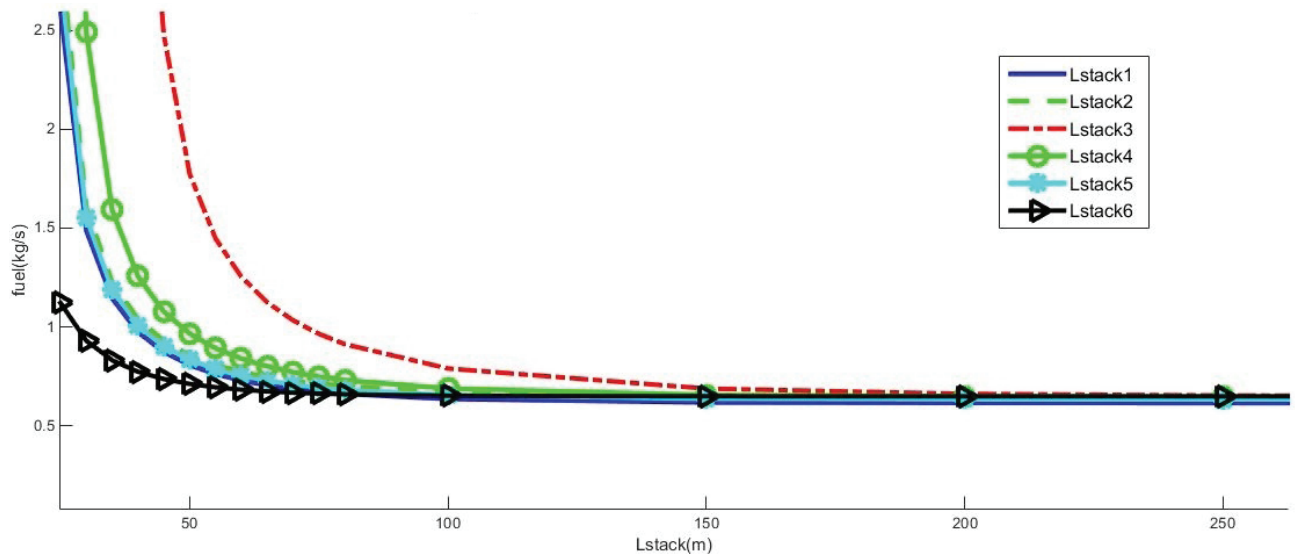

Figure 25. The effect of fire tube length on fuel consumption.

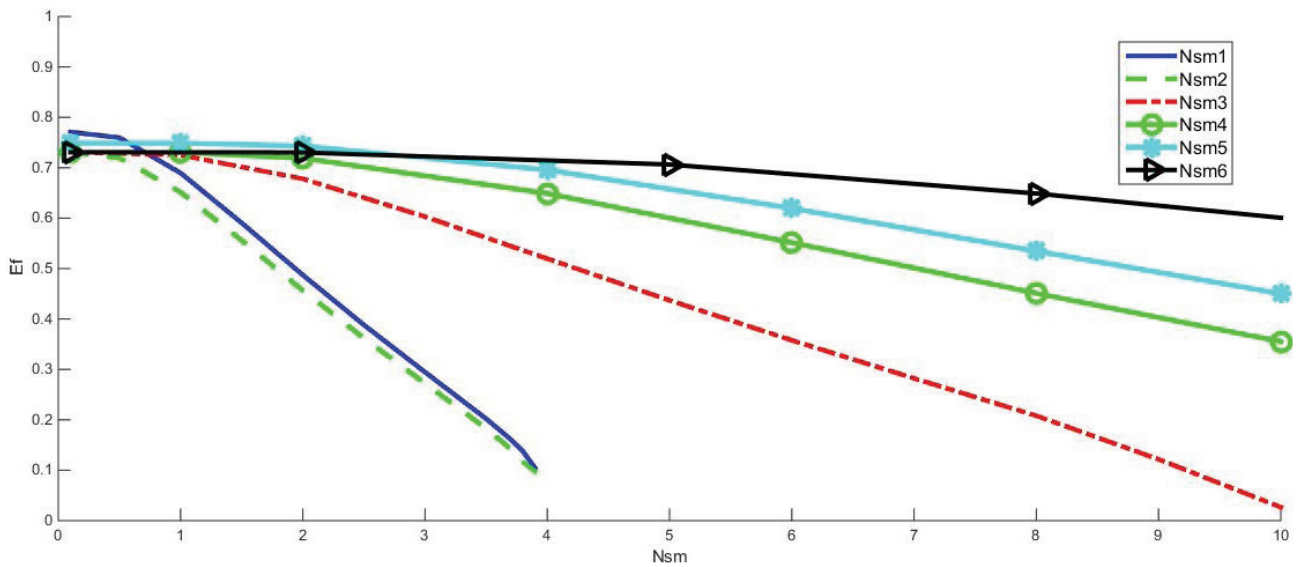

Figure 26. The effect of fire tube number of passes on heater efficiency.

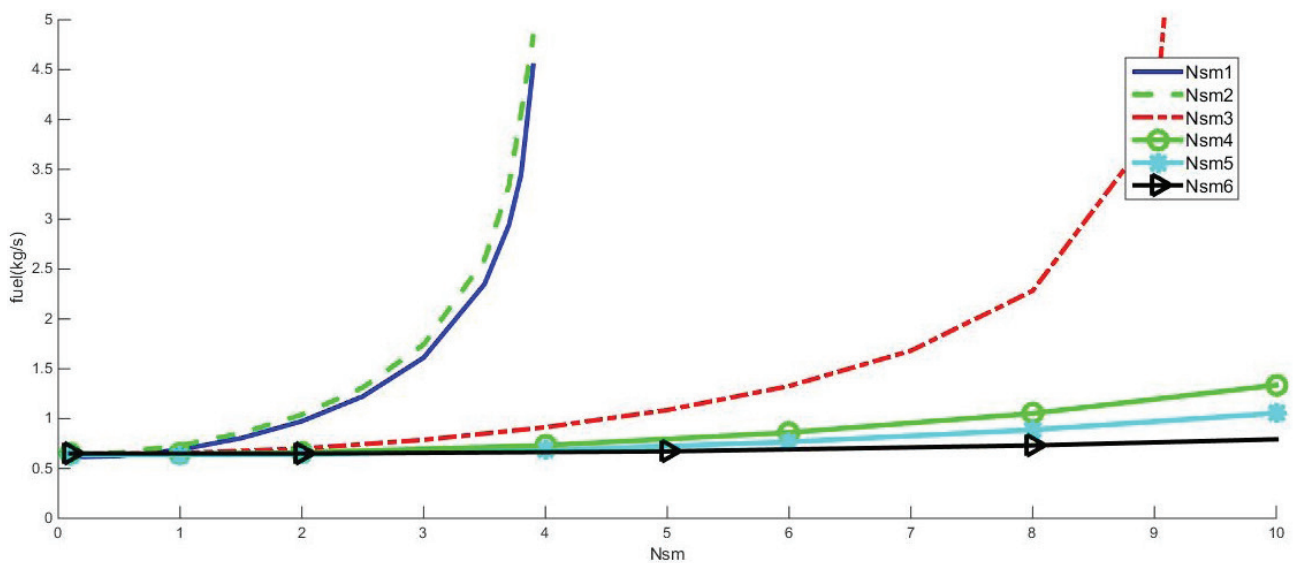

Figure 27. The effect of fire tube number of passes on fuel consumption.

performance. Figures 28 and 29 show the performance of heaters with different model with variations in the width of the heater. Among all models, model 6 is less adversely affected by heater width and has a superior performance.

The effect of insulation thickness

Analytically speaking, increasing the insulation thickness, according to equation (9), will increase the denominator of the equation by which heat loss from the surface will decrease leading to a better performance of the heater. Figure 30 and 31, showing the effect of insulation thickness

on heater efficiency and fuel consumption respectively, confirms the aforementioned analysis. It also can also be observed that after a certain threshold, increasing the insulation thickness becomes less effective and negligible on heater performance.

The effect of volumetric flow rate

According to equation (4), with increasing volumetric flow rate of the gas, the mass flow rate \dot{m}_{Gas} will also increase and considering equation (2), it will increase the efficiency and lowering the fuel consumption. Figure 32

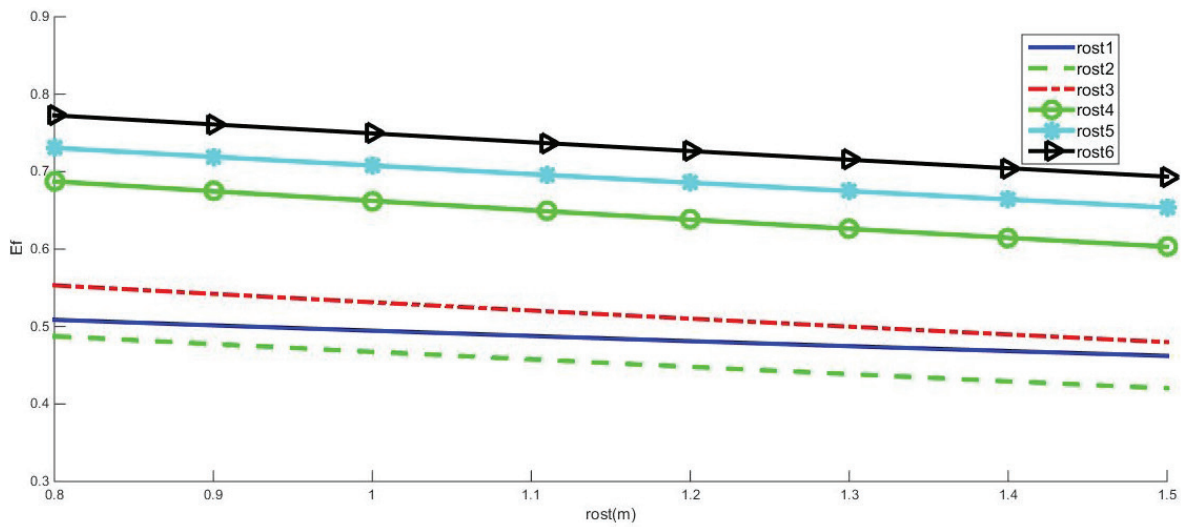

Figure 28. The effect of heater width on heater efficiency.

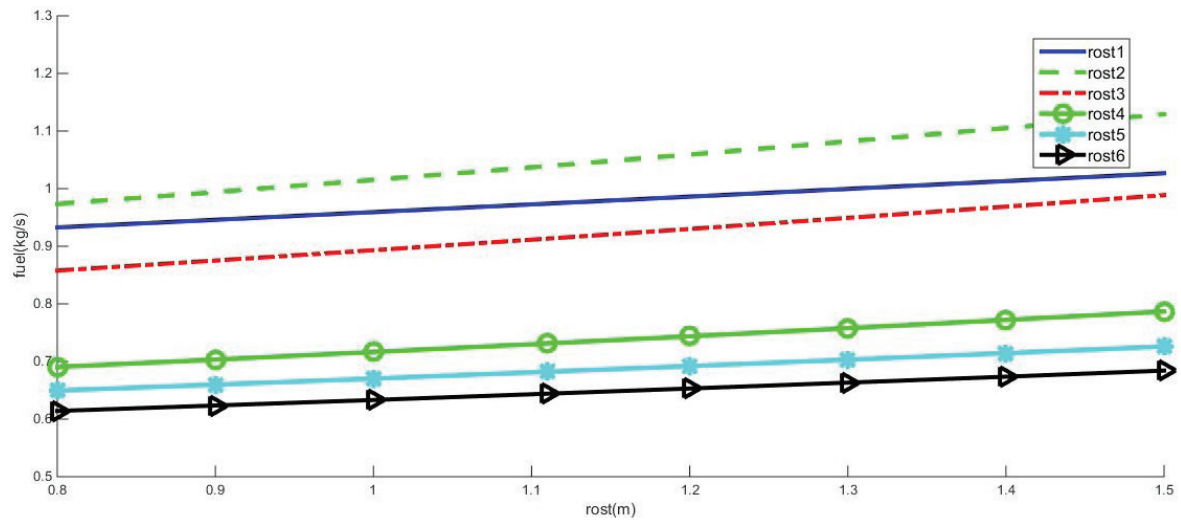

Figure 29. The effect of heater width on fuel consumption.

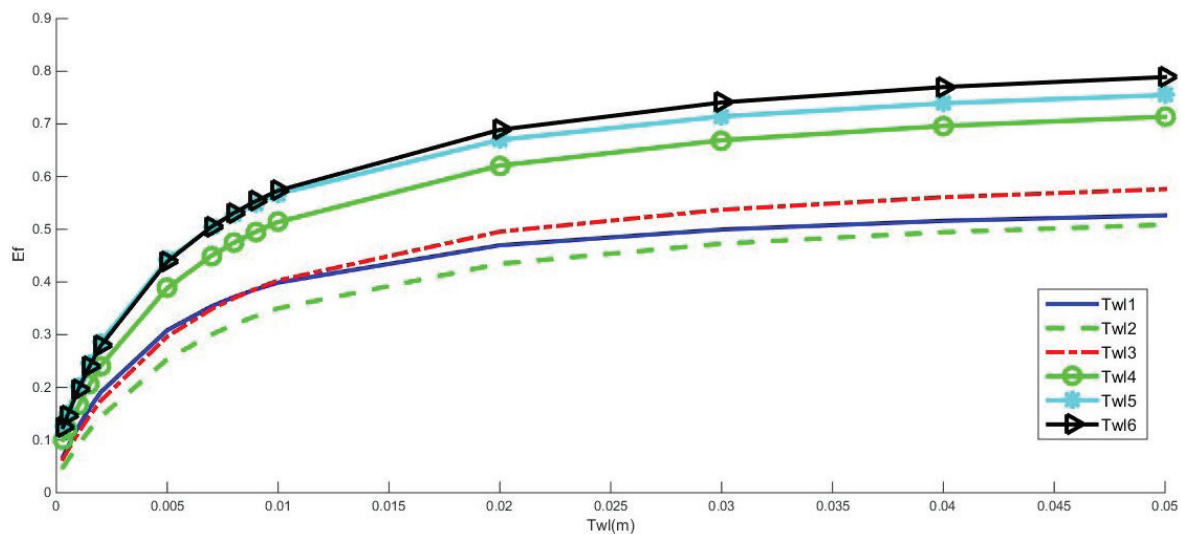

Figure 30. The effect of insulation thickness on heater performance.

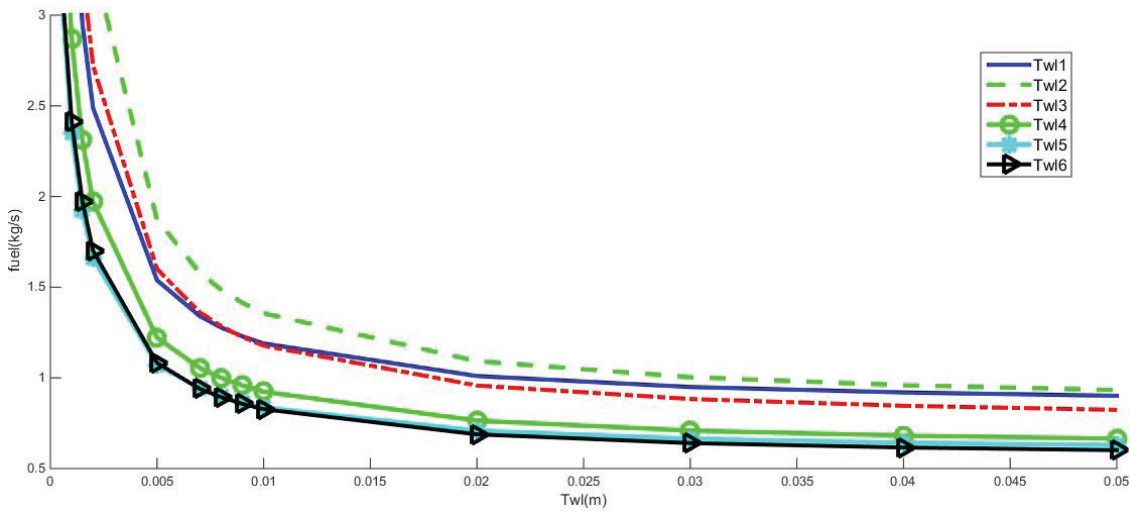

Figure 31. The effect of insulation thickness on fuel consumption.

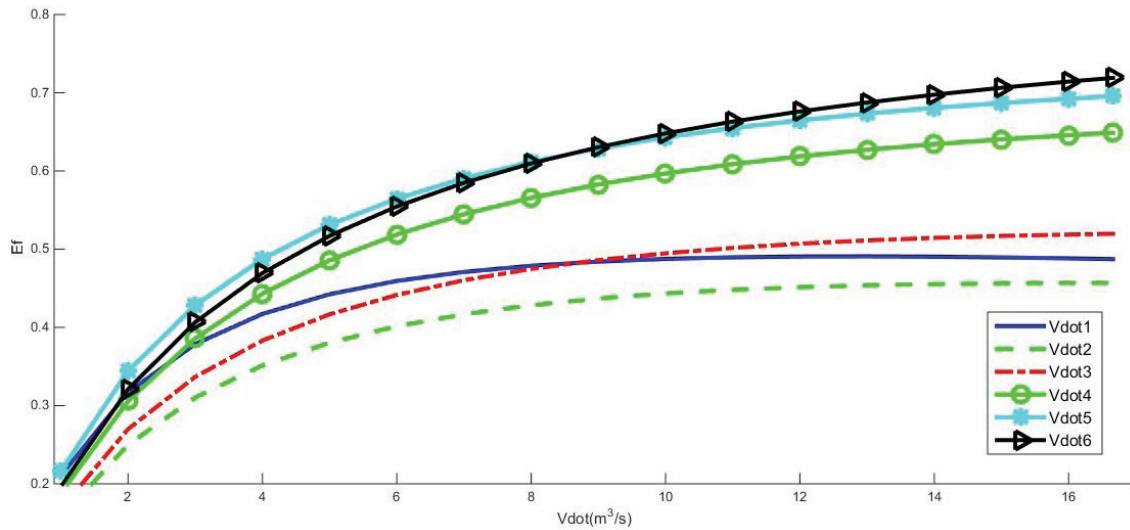

Figure 32. The effect of volumetric flow rate on heater efficiency.

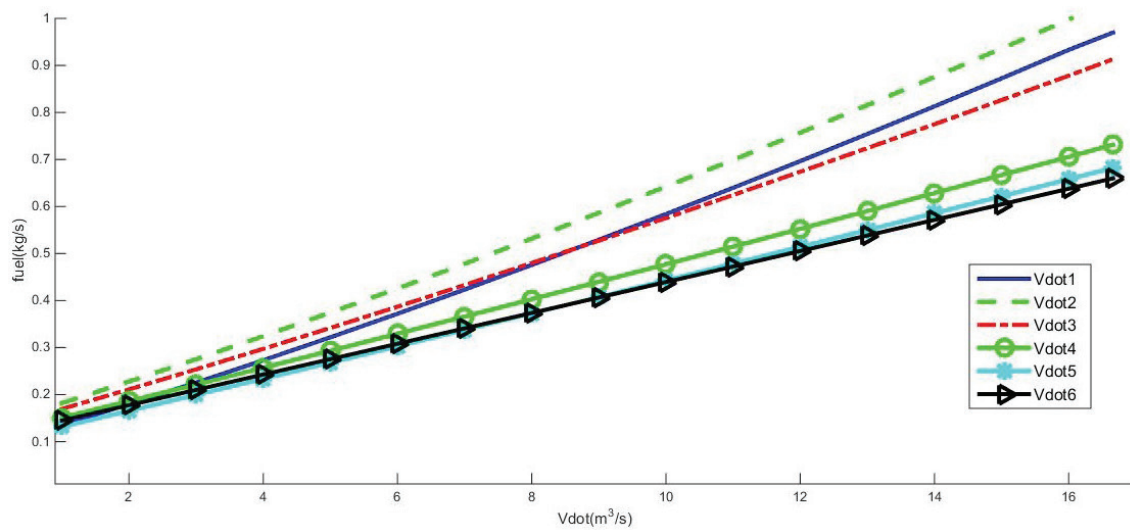

Figure 33. The effect of volumetric flow rate on fuel consumption.

and 33 shows the improvement in heater efficiency and fuel consumption in all models with increasing gas volumetric flow as well as relative better performance of model (6).

OPTIMIZATION

Considering all studied parameters, the heater in model 6 had the most superior thermal performance. Moreover, in examining the effect of different parameters it was observed that the correlation is not uniform which means while for some values the parameter can be influential, for other values it can become nearly ineffective. In an optimized design, in addition to geometrical constraints, economical considerations are important. On the other hand, considering the concurrent effect of all the geometrical parameters is a must for optimization. To achieve the best combination of geometrical parameters, in this study, genetic algorithm (GA) as an evolutionary approach was used. This algorithm, being inspired by natural selection in the nature is one of the most developed methods with discrete variables.

Considering the developed thermal model of the heater, GA can be aimed at finding the combination of the geometrical parameters to yield the lowest fuel consumption and the highest efficiency. The efficiency of the heater is expressed in equation (28).

Where \dot{m}_{fuel} is the mass flow rate of the fuel in $\frac{kg}{s}$, LHV is the low heat value of the natural gas and η_{heater} is the performance efficiency of the heater.

According to this equation, for increasing the efficiency the mass flow rate of fuel should be reduced. But, it is already known that the fuel consumption depends on geometrical parameters through presented formulations. Therefore, here optimization has been performed to minimize fuel consumption while taking into account the geometrical constraints.

The considered geometrical constraints are presented in equations (29) to (34) by which the boundary of the search for optimum parameters will be outlined.

$$\frac{2Np(\pi Dic^2)}{4} + \frac{2Nsm(\pi D_{stack}^2)}{4} < \pi Rost^2 \quad (29)$$

$$\frac{2Np(\pi Dic^2)}{4} Lcoil + \frac{2Nsm(\pi D_{stack}^2)}{4} Lstack < \pi Lst Rost^2 \quad (30)$$

$$\frac{2Np(\pi Dic^2)}{4} + 2Nsm(a_{stack}^2) < ast^2 \text{ for cubic model} \quad (31)$$

$$\frac{2Np(\pi Dic^2)}{4} Lcoil + 2Nsm(a_{stack}^2) Lstack < Lstast^2 \text{ for cubic model} \quad (32)$$

$$Lstack < 2 * Nsm * Lst \quad (33)$$

$$Lcoil < 2 * Np * Lst \quad (34)$$

The constraints are listed at Tables 6 and 7 for heaters with cylindrical and cubic geometries respectively.

Table 6. Geometrical parameters and their alteration range for cylindrical heaters

Parameter	Lower range	Upper range
Lcoil(m)	15	130
Nsm	1	4
Dic(m)	0.05	0.1
Np	1	4
Rost(m)	0.8	1.5
Lst(m)	8	10
D_stack(m)	0.2	0.6
Lstack(m)	30	60

Table 7. Geometrical parameters and their alteration range for cubic heaters

Parameter	Lower range	Upper range
Lcoil(m)	15	150
Nsm	1	4
Dic(m)	0.05	0.1
Np	1	6
Rost(m)	0.8	1.5
Lst(m)	8	10
D_stack(m)	0.2	0.6
Lstack(m)	30	60

Running the algorithm for numerous iterations would converge into the optimized variables for cylindrical and cubic geometries as presented in Tables 8 and 9 respectively.

Table 8. Optimized geometric parameters for cylindrical heater

Capacity (m ³ /hr)	60000
Lcoil(m)	122
Np	4
Dic(m)	0.0724
Rost(m)	1.1067
Lst(m)	8.4511
Nsm	2
D_stack(m)	0.3574
Lstack(m)	37.3363
Efficiency (%)	56.60

Table 9. Optimized geometric parameters for cubic heater

Capacity (m ³ /hr)	60000
Lcoil(m)	131
Np	4
Dic(m)	0.0835
ast(m)	2.0037
Lst(m)	8.0659
Nsm	4
D_stack(m)	0.2019
Lstack(m)	57.2194
Efficiency (%)	76.01

Looking at GA results it can be observed that with the trade-off a slight increase in heat loss from the surfaces, in the optimized combination exhaust heat loss was dramatically dwindled. Another feature is the clear reduction in thermal resistance between the fire tube and distilled water which would lead to superior heat transfer to the gas tube. This consequently resulted in the lower fuel consumption required to bring the gas flow to the certain temperature causing a boost in heater efficiency.

CONCLUSION

CGSs tune the required pressure of the gas pipelines bringing gas to the final users. Joule-Thomson effect will cause a severe fall in gas temperature at the moment of pressure drop in regulators. In order to avoid the formation of gas hydrates then, gas should be warmed up prior to pressure reduction. This is performed by heaters. For safety reasons, the heat is given to the gas indirectly through the intermediate substance, mostly distilled water, in a water bath indirect heater. Being ubiquitous in Iran's CGSs, this type of heater, unfortunately has a very low efficiency-lower than 40%- when it becomes even lower when the CGS does not work in its full capacity. Previous efforts on improving the efficiency mostly focused on adding equipment like economizer, recuperator or solar cells and applying the preheating while finding the optimized geometry was vastly ignored.

Overall, cylindrical heaters are prevalent, but other geometries like cubic ones would give the designer the chance to better position key internal parts of the heater and should be considered. In this study, for the first time, the analysis of cubic geometry for indirect water bath heaters was performed and the effect of different geometric parameters was investigated separately. Increasing the number of passes and also the length of gas tubes, within the same total volume of the heater, has a great contribution to boost the performance of the heater. Though, the mere alteration of the outer shape of the heater from a cylinder to a cube does not improve the efficiency, if the configuration and

positioning of the gas tubes and fire tubes is altered, then the efficiency can be promoted substantially. With analysis performed, the effect of increasing number of passes and length of the fire tube in improving the efficiency was confirmed. Cubic heaters make it possible to increase the length of gas tubes and fire tube. Another finding was to use a cubic geometry for fire tube which was the most effective in improving the performance of the heater as assumed in model 4.

in this study, along with developing a thermal model of the heaters, the validation was performed using recorded data of heater located in Arak CGS with capacity of 60000 SCMH, totally 6 models, the one similar to the validation reference with cylindrical geometry and other 5 with cubic geometry, were considered. It was found that model 6 possess a superior performance than other models in the way that the initial 31.9 % efficiency of the cylindrical shape could be improved to 71.2% in the cubic heater. Using genetic algorithm to optimize indirect water bath heaters with cubic geometry was another new action that was done in this study for the first time. The optimization was performed for all models using genetic algorithm and for the cylindrical and best cubic heaters the efficiency was increased to 56.6% and 76.1% respectively.

NOMENCLATURE

Item Definition	Item signature	Dimension
heater side wall heat loss	Q°_{lost}	kJ/s
gas flow-water heat transfer resistance	R_{totgas}	K/W
heat specific of a component in Natural gas compound	$C_{p Gas}$	kJ/kg. k
Volumetric flow rate	V°_{Gas}	m ³ /s
mass fraction of ith component of natural gas compound	X_i	%
mollar fraction of ith component of natural gas compound	Y_i	%
molecular mass of ith component of natural gas compound	M_i	kg/kmol
total molecular mass of 21-portion natural gas compound	$M_{mix Gas}$	kg/kmol
air flow rate to fire tube	m°_{air}	kg/s
mass flow rate of the fuel to fire tube in ...	m°_{fuel}	kg/s
outer diameter of steel layer	$r_{o steel}$	m
inner diameter of steel layer	$r_{i steel}$	m
steel conductivity coefficient	k_{steel}	W/mK
length of steel layer	L_{steel}	m
outer diameter of glass wool	$r_{o wool}$	m
inner diameter of glass wool layer	$r_{i wool}$	m
glass wool conductivity coefficient	k_{wool}	W/mK
length of glass wool	L_{wool}	m
inner diameter of aluminum layer	$r_{i al}$	m
outer diameter of aluminum layer	$r_{o al}$	m

cross section of aluminum layer	A_{heater}	m	total components of natural gas compound	N	-
ambient convection heat transfer coefficient	h_{air}	W/m ² K	state equation parameters	$u_n, w_n, s_n, q_n, g_n, f_n, a_n$	-
water convection heat transfer	h_{water}	W/m ² K	corresponding characteristics parameter	$W_i, S_i, Q_i, K_i, G_i, F_i, E_i$	-
internal area of steel layer	A_{steel}	m ²	viscosity of each gas component	M	kg/m s
temperature of heater environment	T_{am}	°C	critical temperature of each gas component	T_c	K
temperature of water tank environment	T_w	°C	diameter of components of gas compound	Σ	Nm
mass flow rate to heater stack	m_{smoke}^o	kg/s	critical volume of each component of gas compound	V_c	cm ³ /mole
smoke temperature entering the stack	$T_{smoke.i}$	°C	centrifugal factor for each component of gas compound	$\bar{\omega}$	-
smoke temperature exiting from stack	$T_{smoke.o}$	°C	maximum energy absorbed by each component of gas compound	E	J
specific heat of smoke compound in inlet temperature to stack	$C_{p\ smoke,i}$	kJ/kg. k	molar mass for each component of gas compound	M	kg/kmole
specific heat of smoke compound at outlet temperature to stack which is ambient temperature	$C_{p\ smoke,o}$	kJ/kg. k	Normalized reduced bipolar momentum for each component of gas compound	Ξ	-
specific heat of smoke compound in inlet temperature to fire tube and stack	$c_{p\ ave.smoke}$	kJ/kg. k	Normalized reduced bipolar momentum for each component of gas compound	ξ_r	-
Inner diameter of fire tube	D_{stack}	m	reduced integral for gas components	$\Omega^{(2,2)*}$	-
smoke compound viscosity	μ_{smoke}	N/sm ²			
convection heat transfer coefficient of smoke compound	h_{smoke}	w/m ² k			
Reynolds number of smoke flow	$Re_{D,smoke}$	dim. less			
Pranthe number of smoke compound flow	Pr_{smoke}	dim. less			
conduction heat transfer coefficient of smoke compound	K_{smoke}	W/mk			
fire tube length between combustion chamber and stack	L_{stack}	M			
convection heat transfer coefficient of stack wall	h_{stack}	W/m ² k			
mass flow rate of smoke compound	m_{smoke}^o	kg/s			
natural gas coil inner diameter	D_{coil}	m			
viscosity of natural gas compound	μ_{Gas}	N/sm ²			
convection heat transfer of natural gas compound	h_{coil}	W/m ² k			
Reynolds number of natural gas flow	$Re_{D,Gas}$	dim. less			
Pranthe number of natural gas flow	Pr_{Gas}	dim. less			
conduction heat transfer coefficient of natural gas compound	k_{Gas}	W/mk			
coil surface temperature	T_{surf}	°C			
second virial coefficient	B	-			
reduced viscosity	ρ_r	-			
dual interaction parameter for energy compound	U_{ij}	-			
temperature dependency coefficient	C_n^*	-			
Standard AGA8 equation's parameters AGA8	$kn; cn; an$	-			
molar density	ρ_m	kmol/m ³			
compressibility factor	Z	-			
molar fraction index of ith component	y_i	%			
size parameters	K_i	-			
corresponding dual interaction parameters	K_{ij}	-			

AUTHORSHIP CONTRIBUTIONS

Authors equally contributed to this work.

DATA AVAILABILITY STATEMENT

The authors confirm that the data that supports the findings of this study are available within the article. Raw data that support the finding of this study are available from the corresponding author, upon reasonable request.

CONFLICT OF INTEREST

The author declared no potential conflicts of interest with respect to the research, authorship, and/or publication of this article.

ETHICS

There are no ethical issues with the publication of this manuscript.

REFERENCE

- [1] Barkhordar ZA, Fakouriyan S, Sheykhha S. The role of energy subsidy reform in energy efficiency enhancement: Lessons learnt and future potential for Iranian industries. J Clean Prod 2018;197:542–550. [CrossRef]
- [2] Mokhtab S, Poe WA, Mak JY. Handbook of natural gas transmission and processing. 4th ed. Houston, Texas: Gulf Professional Publishing; 2019. [CrossRef]

- [3] Saadat-Targhi M, Khanmohammadi S. Energy and exergy analysis and multi-criteria optimization of an integrated city gate station with organic Rankine flash cycle and thermoelectric generator. *Appl Therm Eng* 2019;149:312–324. [\[CrossRef\]](#)
- [4] Rahmati AR, Reiszadeh M. An experimental study on the effects of the use of multi-walled carbon nanotubes in ethylene glycol/water-based fluid with indirect heaters in gas pressure reducing stations. *Appl Therm Eng* 2018;134:107–117. [\[CrossRef\]](#)
- [5] Rastegar S, Kargarsharifabad H, Rahbar N, Behshad Shafii M. Distilled water production with combination of solar still and thermosyphon heat pipe heat exchanger coupled with indirect water bath heater-experimental study and thermoeconomic analysis. *Appl Therm Eng* 2020;176:115437. [\[CrossRef\]](#)
- [6] Gunes S, Ozceyhan V, Buyukalaca O. The experimental investigation of heat transfer and pressure drop in a tube with coiled wire inserts placed separately from the tube wall. *Appl Therm Eng* 2010;30:1719–1725. [\[CrossRef\]](#)
- [7] Ashouri E, Veysi F, Shojaeizadeh E, Asadi M. The minimum gas temperature at the inlet of regulators in natural gas pressure reduction stations (CGS) for energy saving in water bath heaters. *J Nat Gas Sci Eng* 2014;21:230–240. [\[CrossRef\]](#)
- [8] Azizi SH, Rashidmardani A, Andalibi MR. Study of preheating natural gas in gas pressure reduction station by the flue gas of indirect water bath heater. *Int J Sci Eng Investig* 2014;3:17–22.
- [9] Khalili E, Hoseinalipour SM, Heybatian E. Efficiency and heat losses of indirect water bath heater installed in natural gas pressure reduction station; evaluating a case study in Iran. The 8th National Energy Congress, 24 May-25 June, 2011, Tehran, Iran. Tehran: National Energy Committee of the Islamic Republic of Iran; 2011.
- [10] Sabermoghaddam A, Farhadiyan N, Sheikhiyani H. Feasibility of energy optimization in the heaters of the gas pressure reduction station. The 5th National Conference on CFD Applications in the Chemical and Petroleum Industries, 21 May, 2014, Tehran, Iran. Tehran: Iran University of Science and Technology; 2014.
- [11] Hossein SS, Farhadi M, Sedighi K. Experimental investigation of a solar desalination system using twisted tape and wire coil inside of spiral heat exchanger. *Desalination* 2017;42:34–44. [\[CrossRef\]](#)
- [12] Wu Z, Wang L, Sundén B. Pressure drop and convective heat transfer of water and nanofluids in a double-pipe helical heat exchanger. *Appl Therm Eng* 2013;60:266–274. [\[CrossRef\]](#)
- [13] Dizaji, Jafarmadar S, Hashemian M. The effect of flow, thermodynamic and geometrical characteristics on exergy loss in shell and coiled tube heat exchangers. *Energy* 2015;91:678–684. [\[CrossRef\]](#)
- [14] Farzaneh-Gord M, Arabkoohsar A, Deymi Dashtbayaz M, Farzaneh-Kord V. Feasibility of accompanying uncontrolled linear heater with solar system in natural gas pressure drop stations. *Energy* 2012;41:420–428. [\[CrossRef\]](#)
- [15] Rashidmardani A, Hamzei M. Effect of various parameters on indirect fired water bath heaters' efficiency to reduce energy losses. *Int J Sci Eng Investig* 2013;2:17–24.
- [16] Ghaebi H, Farhang B, Rostamzadeh H, Parikhani T. Energy, exergy, economic and environmental (4E) analysis of using city gate station (CGS) heater waste for power and hydrogen production: A comparative study. *Int J Hydrog Energy* 2018;43:1855–1874. [\[CrossRef\]](#)