



Düzce University Journal of Science & Technology

Research Article

Design Of Gravity Separator For Recovery Of Two Different Metal Group

 Hasan ER ^{a,*},  Ziya ÖZÇELİK ^b

^a Mekatronik Mühendisliği Bölümü, Teknoloji Fakültesi, Selçuk Üniversitesi, Konya, TÜRKİYE

^b Mekatronik Mühendisliği Bölümü, Teknoloji Fakültesi, Selçuk Üniversitesi, Konya, TÜRKİYE

Sorumlu yazarın e-posta adresi: erhasan@rocketmail.com

DOI:10.29130/dubited.1351178

ABSTRACT

This study, "Design of a Gravity Separator for the Recovery of Two Different Metal Groups", represents important research aiming to recover metals in a sustainable way and reduce the amount of waste. This study aims to separate metals according to their density differences. It is an effective method, especially for the separation of different metals such as copper and aluminum. Therefore, this study investigates how this technology can be used more efficiently. As a result of the literature review, existing gravity separation techniques were evaluated. This formed the basis for a new and novel gravity separator design based on existing knowledge. This design is designed to have a capacity of one ton per hour. This capacity demonstrates usability on an industrial scale. The designed separator aims to separate mixed copper and aluminum pieces and convert them into pure granule raw material. During the implementation phase, it was tested how this design would perform in the field. As a result of these tests, it is aimed to recover approximately 8760 tons of waste material annually. This makes a positive contribution to the environment by recycling large amounts of waste material. In conclusion, this study highlights an important method for sustainable recovery of metals. The effective use of gravity separation technology is of great importance in reducing the amount of waste and protecting natural resources. This study is an important step in highlighting sustainability and environmentally friendly practices.

Keywords: Gravity Separation Technology, Metal Recovery, Sustainability

Farklı İki Metal Grubun Geri Kazanımı için Gravite Ayırıcısı Tasarımı

ÖZET

"Farklı İki Metal Grubun Geri Kazanımı için Gravite Ayırıcısı Tasarımı" adlı bu çalışma, metallerin sürdürülebilir bir şekilde geri kazanılmasını ve atık miktarının azaltılmasını amaçlayan önemli bir araştırmayı temsil eder. Bu çalışma, metallerin yoğunluk farklarına göre ayrılmasını sağlamaktadır. Özellikle bakır ve alüminyum gibi farklı metallerin ayrılması için etkili bir yöntemdir. Bu nedenle, bu çalışma bu teknolojinin nasıl daha verimli bir şekilde kullanılabileceğini araştırmaktadır. Literatür taraması sonucunda, mevcut gravite ayırma teknikleri değerlendirilmiştir. Bu, mevcut bilgiye dayalı olarak yeni ve özgün bir gravite ayırıcısı tasarımının temelini oluşturulmuştur. Bu tasarım, saatte bir ton kapasiteye sahip olacak şekilde tasarlanmıştır. Bu kapasite, endüstriyel ölçekte kullanılabilirliği

göstermektedir. Tasarlanan ayırıcı, karışık bakır ve alüminyum parçalarını ayrıştırarak saf granür hammaddeye dönüştürmeyi hedefler. Uygulama aşamasında, bu tasarımın sahada nasıl performans göstereceği test edilmiştir. Bu testler sonucunda, yıllık olarak yaklaşık 8760 ton atık maddenin geri kazanılması hedeflenmektedir. Bu, büyük miktarlarda atık maddenin geri dönüşümünü sağlayarak çevreye olumlu bir katkı yapmaktadır. Sonuç olarak, bu çalışma, metallerin sürdürülebilir bir şekilde geri kazanılması için önemli bir yöntemi vurgulamaktadır. Gravite ayırma teknolojisinin etkili kullanımı, atık miktarının azaltılması ve doğal kaynakların korunması açısından büyük öneme sahiptir. Bu çalışma, sürdürülebilirlik ve çevre dostu uygulamaların öne çıkarılmasında önemli bir adımdır.

Anahtar kelimeler: Gravite Ayırma Teknolojisi, Metal Geri Kazanımı, Sürdürülebilirlik

Received: 28/08/2023, Revised: 29/08/2023, Accepted: 27/09/2023

I. INTRODUCTION

Increasing industrialization around the world leads to a decrease in precious metal resources and waste management problems. In particular, the recovery of valuable metals such as copper and aluminum contained in electronic waste is critical both economically and environmentally. Current technological methods are insufficient to recover these metals. Gravity separation technology aims to recover materials with low energy and in an environmentally friendly process by using density differences. In this thesis, a gravity separator supported by mechatronic principles was designed and experimentally tested for the effective recovery of copper and aluminum. The efficiency of the designed device is increased with elements such as fans and vibrating tables. This study aims to provide an innovative solution to the challenges in waste management and aims to contribute to the literature on sustainable recovery of metals.[1]

Gravity separators are used to separate materials of different densities. The basic working principles are that materials move depending on their density. The separator types used can be examined under the main headings: jig separators, spirals, tables and centrifugal separators. [2,3]

Technological advancements have facilitated these separators becoming more efficient and eco-friendly. Each separator type has specific advantages and disadvantages. Therefore, it is essential to consider the characteristics of the processed ore, processing objectives, and other factors when determining which type to employ [4].

The machine developed within the scope of this study has a pioneering character in its application field. Therefore, there appear to be no similar projects in the literature. However, a comprehensive literature review was conducted with a focus on gravity separators and metal recycling. In this process, some key studies examined are detailed as follows:

Studies by Jing et al. (2017) and Guo et al. (2020) revealed the effectiveness of jig separators in separating coarse-grained materials in the mining industry; however, they had limited success with fine-grained materials. Interestingly, these separators were employed to segregate plastics like polystyrene (PS), acrylonitrile butadiene styrene (ABS), and polyethylene terephthalate (PET) found in photocopier waste. Under the influence of amplitude and frequency of water pulsation, these plastics were successfully separated with recovery rates of 99.8% PS, 99.3% ABS, and 98.6% PET in the upper, middle, and lower layers, respectively. These positive results sparked the idea of establishing a pilot facility for plastic recycling from scrap photocopiers.

Lopéz-Valdivieso et al. (2018) and Huang et al. (2021) noted the efficacy of table usage in applications like gold mining. They also highlighted that tables' usage facilitated the separation of less dense materials at higher speeds.

Miller and Jones (2020) and Singh et al. (2017) demonstrated the efficiency of centrifugal separators in the separation of dense materials. These separators are particularly effective in the recovery of metals due to the substantial density difference between heavy metals and light materials.

Yoon et al. (2016) demonstrated that flotation cells are particularly effective in mineral mining. However, they highlighted some environmental concerns associated with using this technology.

Honaker et al. (2007) emphasized that the design and performance of gravity separators significantly vary depending on the specific application. They reviewed various gravity separation technologies and performance evaluations.

Rao (2006) extensively explored gravity separators as a potential method for metal recovery. They examined how various gravity separation techniques could be employed for metal recovery.

Chen et al. (2011) highlighted the potential of using gravity separators to increase metal recovery while reducing environmental impact. Future research in this area should focus on improving the efficiency and environmental compatibility of gravity separation technologies.

Sivamohan et al. (1991) discussed that gravity separators are devices based on the principle of separating materials using density differences. These devices have found widespread applications in various industries, especially in mining and waste management sectors.

This literature review encompasses the diversity of gravity separation technologies and their applications in metal recovery. Existing literature highlights the customization of these techniques for specific material types and conditions. However, there is a clear demand for a gravity separator capable of adapting to various situations and effectively distinguishing different metal groups. This study was prepared to address this need and design a comprehensive gravity separator.

In this study, a table gravity separator design using air was preferred. The basic components of these separators are the separation table, fan/aspirator, motor and power transmission elements, and the frame and support structure. These separators are designed to separate metal powders according to their specific gravity differences. It is especially used in the enrichment of fine-grained and high specific gravity minerals. Working principles may vary depending on grain size. During separation, heavy grains are moved upwards by the effect of vibration and light grains remain below [5,6].

II. GRAVITY SEPARATOR DESIGN STAGES FOR RECOVERY OF TWO DIFFERENT METAL GROUPS

In industrial applications, two metals commonly used are Copper (Cu) and Aluminum (Al), which stand out due to their distinct difference in specific gravity. With a density of 8.94 g/cm³, copper's value is significantly higher than aluminum's 2.70 g/cm³. This difference allows gravitational separation methods to effectively differentiate between these two metals. These metals, which are present across a broad spectrum from electronics to mechanics, hold critical importance in recycling processes. The rich resource offered by scrap trading companies makes the evaluation of these metals in the context of sustainability inevitable. This study discusses the details and application steps of a system designed for the effective separation of copper and aluminum.

The design of the separation table, where these materials will be added, is as significant as the materials used in the separation process. Within the scope of this project, a separation table, specially designed in the Solidworks program, is used. In this table, an aluminum alloy sheet metal known for its durability and workability is combined with a chromium alloy material. The aluminum alloy sheet used in the sieve structure, with a thickness of 5 mm, is suitable for long-term use due to its lightweight and rustproof properties. A mesh of 250-micron thickness has been placed on this metal, aiming to provide excellent filtration. This mesh has been secured using riveting for enhanced durability.

Moreover, a chromium alloy material with a thinner and more flexible structure, 1.2 mm in thickness, has been chosen for surfaces in direct contact with the separated materials. These surfaces prevent any damage to the materials during the separation process.

This special design guarantees a more effective and efficient separation process. Figure 1 provides a detailed illustration of the designed separation table.

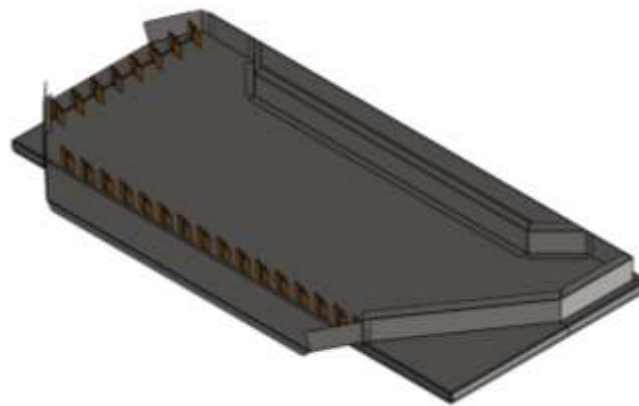

Figure 1. 3D design of the separation table

Fans that ensure air flow play a critical role in the effective operation of gravity separators. In this project, after comprehensive research on fan selection, it was decided that the radial fan was the most appropriate. The number of blades on radial fans can vary depending on factors such as aerodynamic performance, noise level, and torque balance. Generally, these fans range from 6 to 12 blades, but aiming for high pressure with 40 blades was targeted according to the specific requirements of this project. In summary, the design parameters are as follows:

Table 1. The design parameters

Parameter	Value
Air Flow Rate	2500 m ³ /h
Fan Efficiency	80%
Affected Area	0.00586666 m ²
Force Produced by the Fan	26.66N
Resulting Pressure	Approximately 4544.58 Pa
Power Required for the Fan to Operate:	Approximately 3.155 kW
Actual Power Consumption Required by the Fan	Approximately 3.94375 kW

Based on this evaluation, it was concluded that an energy source of approximately 4 kW is needed for the selected radial fan to operate effectively. Visual materials related to the detailed design and assembly of the fan are found in Figure

2 (a) and (b). This is a critical step in ensuring the effective and efficient operation of the gravity separator.

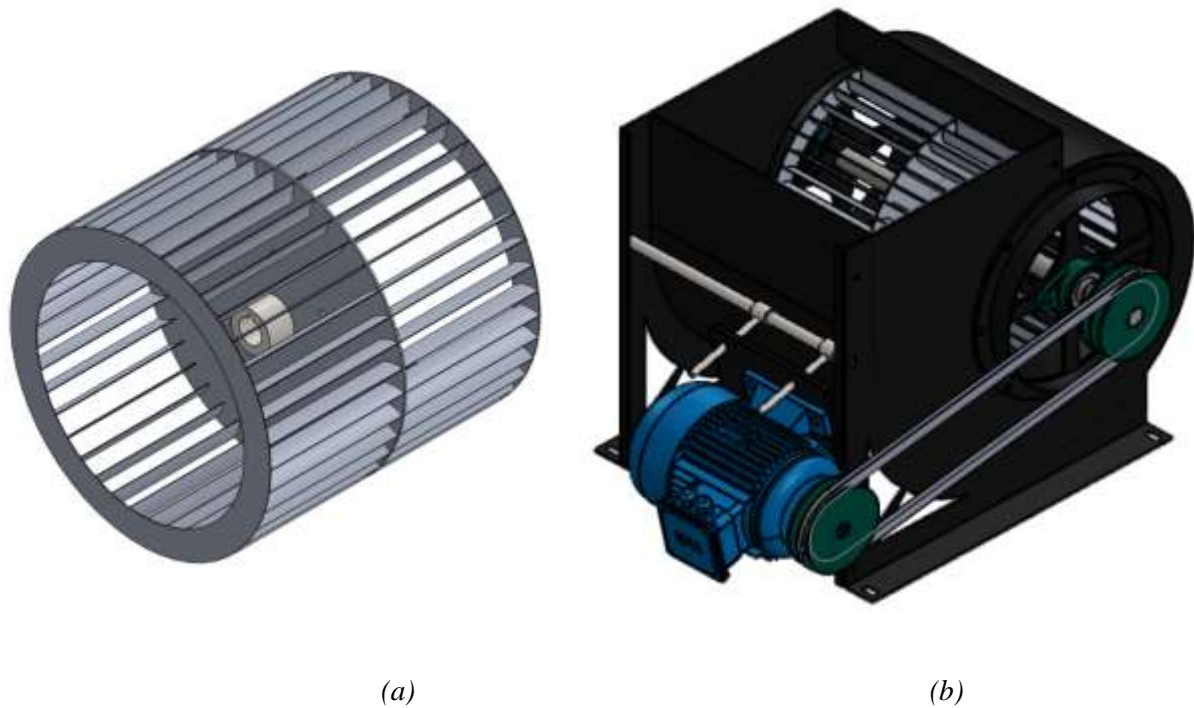

Figure 2. (a) 3D image view of the radial fan and (b) Assembly view of the radial fan and motor

In the gravity separator design project, the importance of the oscillating carrier arm is significant in ensuring the recovery of the separated metals. This carrier arm facilitates the effective and efficient operation of the separation table. Correctly calculating the forces and loads acting on the table ensures the efficient operation of the carrier arm and guarantees the overall safety of the system. The oscillations of the Rosta company's AU, AUI, and STI series are ideal for this application. Considering that the separation table weighs approximately 195 kg, it has been calculated that an additional load of 100 kg will be added to this table. The AU27 and AU27L series oscillating carrier arms were chosen to withstand this load.

The resonance capability factor obtained from the vibration calculations allows the system to be defined as a "natural frequency shaker". By inversely connecting the AU27 and AU27L series carrier arms to each other, a total of 10 oscillating carrier arms have been used in the designed system. The inversely mounted state of the used arms is shown in Figure 3.

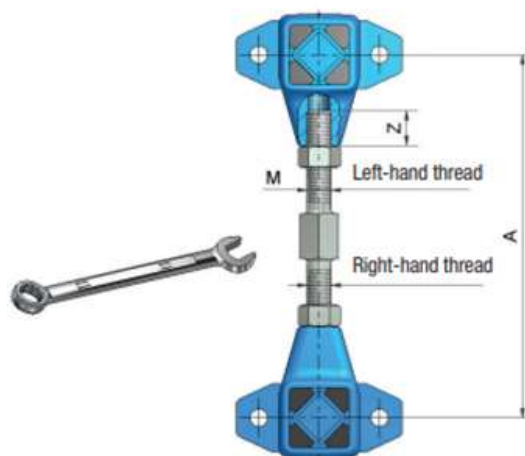

Figure 3. Connected oscillating carrier arm (www.rosta.com)

These choices and the design process ensure the separator table operates in a stable and efficient manner. The detailed 3D visual of the completed design is presented in Figure 4. This design has been optimized to maximize the recovery of different metal groups."

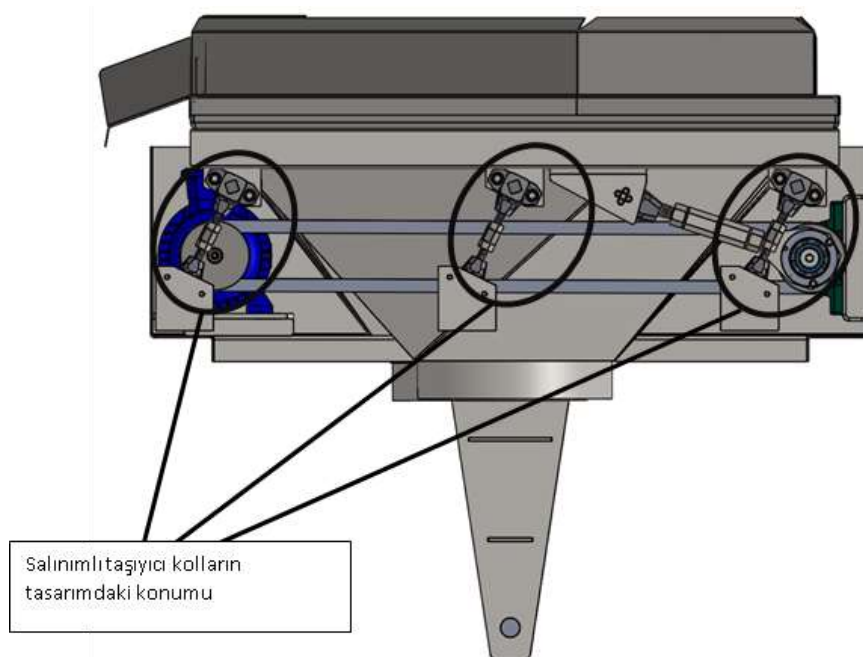

Figure 4. Placement of the carrier arms in the design

The vibrating table is designed with a special movement mechanism to selectively separate metal powders. For automatic vertical movement, it has a V-shaped special design and a square threaded nut; this is driven by a motor and a reducer with a power of 1.5 kW and a speed of 38 rpm. A manual mechanism is used for horizontal movement. The table can move horizontally at a maximum angle of 6°.

In the middle of the table, there is a V-shaped plate that controls movement. In the center of the plate, there's a circular hole guiding the movement of the square threaded shaft. The manual square threaded shaft for horizontal movement is designed to be compatible with the automatic vertical movement mechanism.

The combination of these complex mechanisms ensures effective separation of metal powders. The vibrating table provides the user with flexibility and control with both automatic and manual movement capabilities. The success of the design has been made possible through careful planning and appropriate material selection.

Lastly, the chassis design is one of the most critical stages in a product's design process, as this stage brings together all the components and provides the basic structure that ensures the system operates stably and efficiently. The St37 material used increases the durability of the chassis while offering ease of assembly and transportation due to its lightweight. It is also equipped with special slots and connection points to enhance fan assembly and mobility. The chassis, user-friendly and easy to maintain, should also be aesthetically appealing. Careful planning and appropriate resource allocation are required for a successful chassis design. The detailed chassis design is presented in Figure 5.

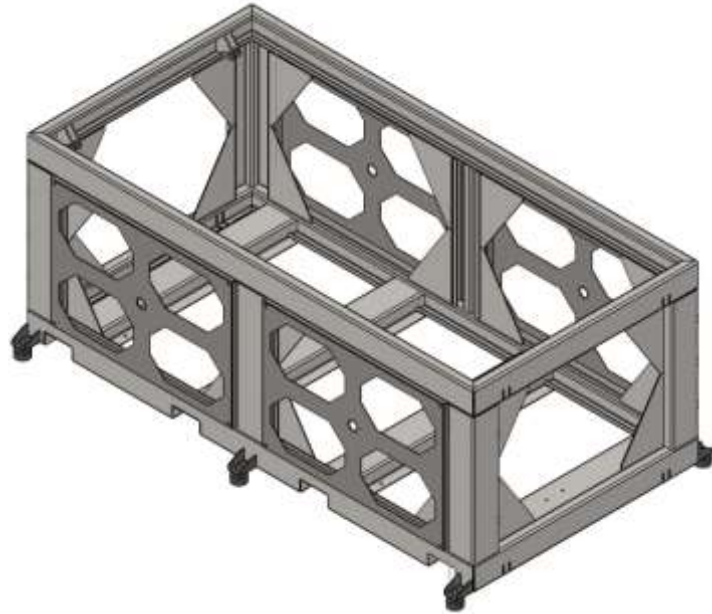

Figure 5. Main Chassis Design

The design of all the parts was completed using the SolidWorks program. The exact dimensions of the finished design were transferred to the KeyShot program, where they were rendered. The rendered image of the design is presented in Figure 6.



Figure 6. Rendered image of the gravity separator design for the recovery of two different metal groups.

III. CONCLUSION

The design of this gravity separator offers a number of significant advantages, targeting the recovery of different metals. We can explain these advantages item by item as follows:

- This separator makes it possible to separate approximately 1 ton of mixed materials per hour. This means a huge efficiency increase in industrial recovery processes. When more materials are recovered, resources are used more efficiently.
- The separator can work on a wide range of material sizes from 1mm to 6mm. This feature allows different materials to be effectively separated in the same process. Industrial waste in particular often comes in different sizes and shapes, so this wide range is important.
- Being able to separate 8,760 tons of material annually allows the recycling of large amounts of waste. This makes a great contribution to reducing the amount of waste and preserving natural resources.
- Increasing efficiency in industrial processes leads to lower production costs and reduced waste disposal costs. This provides economic advantages for businesses.
- Gravity separator plays an important role not only in terms of waste management, but also in protecting natural resources and building a sustainable future. Recycling waste contributes to reducing environmental impacts and increases society's environmental awareness.

These advantages offer significant gains both economically and environmentally. Gravity decomposers help make waste management and recycling processes more efficient, while contributing to a more sustainable use of natural resources. Therefore, this technological tool makes great contributions to the industry, environment and society by adopting the principle of sustainability. It represents a promising step towards the long-term well-being of our planet.

IV. REFERENCES

- [1] Sivamohan, R., & Forssberg, E. Principles and practice of air-table separation technology. *International Journal of Mineral Processing*, (1991). 8(2), 81-89.
- [2] Haldar, S.K. *Mineral Exploration: Principles and Applications*, (2018), Ch. 13, pp. 259-290
- [3] Hacifazlıoğlu., H. İstanbul Üniversitesi, Mühendislik Fakültesi Maden Mühendisliği Bölümü Ders Notu, İstanbul, (2015)
- [4] Çilingir, Y. *Metalik cevherler ve zenginleştirme yöntemleri (2.Baskı)*. İzmir: *Dokuz Eylül Üniversitesi Mühendislik Fakültesi Basım Ünitesi*, (1996).
- [5] Tavares, L. M., & King, R. P. (2012). Single and multi-particle breakage in bench scale shaking table tests. *Minerals Engineering*, 39, 113-122.

- [6] Xu, X., Yin, Z., & Zhang, J. (2015). Experimental design technique on recovery and grade of gold from a gold ore by means of shaking table. *Particulate Science and Technology*, 33(4), 238-244.
- [7] Jing, L., Chen, Q., Gu, Y., & Zhang, Y. (2017). A study on jig separation of scrapped metals. *Minerals Engineering*, 34, 33-39.
- [8] Guo, Z., Wang, Z., Dai, Z., & Li, Z. (2020). A novel pneumatic jig for the dry beneficiation of coal. *Powder Technology*, 360, 630-644.
- [9] López-Valdivieso, A., Song, S., Reyes-Bahena, J. L., & Razo-Soto, I. (2018). The use of shaking tables for the assessment of the separation of primary resources. *Minerals Engineering*, 119, 76-81.
- [10] Huang, P., Zhou, Q., Zhao, Y., & Zhang, J. (2021). Recovery of precious metals from electronic waste and spent catalysts: A review. *Journal of Hazardous Materials*, 403, 123984.
- [11] Miller, J., & Jones, M. (2020). Enhanced gravity separators: new alternatives for fine coal cleaning. *Minerals and Metallurgical Processing*, 17(1), 37-42.
- [12] Singh, R., Rath, B. B., Sinha, S., & Sahu, H. B. (2017). An overview of the beneficiation of iron ores via reverse cationic flotation. *International Journal of Mineral Processing*, 127, 62-69.
- [13] Yoon, R. H., Luttrell, G. H., & Adel, G. T. (2016). Advanced fine coal cleaning technologies: flotation columns and selective flocculation. *Mining, Metallurgy & Exploration*, 9(4), 187-192.
- [14] Honaker, R., Luttrell, G., & Yoon, R. (2007). Advanced fine coal beneficiation technologies for domestic applications: Final technical report. Lexington, KY: *Department of Mining Engineering, College of Engineering, University of Kentucky*
- [15] Rao, S. R. (2006). Minerals recovery and processing. In: *Kirk-Othmer Encyclopedia of Chemical Technology* (pp. 1-48). John Wiley & Sons
- [16] Chen, J., Huang, K., & Xu, Z. (2011). Influence of particle size on distribution of metals in soil-aggregate systems: A case study. *Journal of Hazardous Materials*, 185(2-3), 863-869
- [17] Sivamohan, R., & Forssberg, E. (1991). Principles and practice of air-table separation technology. *Minerals & Metallurgical Processing*, 8(2), 81-89.
- [18] Hacifazlıoğlu H., (1998) "Industrial Applications of A New Type Autogeneous Medium Cyclone (DDS)", *22nd World Mining Congress and Expo*, 11-16 September, Istanbul., pp.519-522,2011.
- [19] Önal G. ve Güney A., "Kömür hazırlama yöntemleri ve tesisleri", Kömür, ed. O. Kural, Özgün Ofset Matbacılık A.Ş., İstanbul, s.269- 295.