



## Investigation of The Effect of Gravity-Film Heat Exchanger on Hot Water Production

### Sıcak Su Elde Edilmesinde Gravity-Film Isı Değiştiricisinin Etkisinin İncelenmesi

Gözde Ural<sup>1</sup>, Hüsamettin Tan<sup>1\*</sup>, Ali Erişen<sup>2</sup>

<sup>1</sup>Mechanical Engineering, Kırıkkale University, Yahşihan/Kırıkkale, TÜRKİYE

<sup>2</sup>Department of Industry Engineering, Ostim Technical University, Ostim, Yenimahalle/Ankara, TÜRKİYE

Başvuru/Received: 27/09/2023

Kabul / Accepted: 09/02/2024

Çevrimiçi Basım / Published Online: 30/06/2024

Son Versiyon/Final Version: 30/06/2024

#### Abstract

The highest energy consumption sector in the worldwide varies according to different needs in residential areas. Energy losses occur in homes, workplaces, etc., due to water discharged into sewage systems. In this study, three different system designs were developed to reuse this energy: electric water heater for hot water production (M-1), electric water heater-GFHE for hot water production (M-2), and heat pump-GFHE for hot water production (M-3). Energy balance equations and empirical equations were used for the analysis of these systems. The study investigates the impact of different shower water temperatures and flow rates. In the comparison of the systems, energy consumption and COP values have been investigated. The results showed that the design with the lowest energy consumption was the system that produced hot water with a heat pump-GFHE. Energy consumption decreased by approximately 88% to 90%, and the COP value increased by a factor of 8.9 to 11.24. The use of an electric water heater alone was seen as unsuitable due to its high energy consumption. It was determined that the use of GFHE for preheating water provided a significant improvement in system performance. The contribution of this study to the literature emphasizes the importance of more sustainable and effective system designs in terms of energy efficiency.

#### Key Words

“Gravity-Film Heat Exchanger, Heat Pump, Waste Heat, Energy”

#### Öz

Dünya genelinde en yüksek enerji harcanan sektör konutlarda farklı ihtiyaçlar doğrultusunda meydana gelmektedir. Evlerde, işyerlerinde vb. kanalizasyona atılan su ile enerji kayıpları yaşanmaktadır. Bu enerjinin kazanılması amacıyla bu çalışmada üç farklı sistem tasarımı yapılmıştır. Bunlar: elektrikli ısıtıcı ile sıcak su üretimi (M-1), elektrikli ısıtıcı-GFHE ile sıcaklık su üretimi (M-2) ve ısı pompası-GFHE ile sıcaklık su üretimi (M-3) şeklindedir. Sistemler için enerji denge bağıntıları ve ampirik bağıntılar kullanılarak analizler yapılmıştır. Çalışmada farklı duş suyu sıcaklıkları ve debi oranlarının etkisi incelenen parametreler arasındadır. Sistemlerin karşılaştırılmasında enerji tüketimi ve COP değerleri karşılaştırılmıştır. Sonuçlar en düşük enerji tüketimine sahip olan tasarım ısı pompası-GFHE ile sıcak su üretilen sistem olduğunu göstermiştir. Enerji tüketiminin %88-%90 oranında azaldığı ve COP değerinin 8.9-11.24 katına çıkmıştır. Tek başına elektrikli ısıtıcı kullanımının yüksek enerji tüketimi sebebiyle uygun olmadığı görülmüştür. GFHE kullanımının suyun ön ısıtılmasını sağlayarak sistem performansında önemli bir iyileştirme yaptığı belirlenmiştir. Bu çalışmanın literatüre katkısı, enerji verimliliği açısından daha sürdürülebilir ve etkili sistem tasarımlarının önemini vurgulamaktadır.

#### Anahtar Kelimeler

“Gravity Film Isı Değiştirici, Isı Pompası, Atık Isı, Enerji”

## 1. Introduction

Hot water consumption in buildings generally arises from the need for cleaning and meal preparation. It is known that the amount of energy used to meet the demand for hot water in buildings accounts for approximately 20% of the total energy consumption (Yao & Steemers, 2005). Considering the depletion of energy resources and environmental impacts, this percentage is of significant importance. The European Union has also reported similar proportions of energy consumption for hot water in total energy consumption (Salama & Sharqawy, 2020). Consequently, reducing energy consumption has become a focus of interest for researchers in this context.

When looking at the distribution of hot water consumption within a household, it is generally used for bathing, showering, dishwashing, and washing machine. The studies conducted in the United Kingdom have determined that, within this distribution, bath and shower usage accounts for 70% of the total hot water consumption (Defra Report, 2008). Therefore, ensuring the recovery of heat from the water discharged during showers and baths, which have a high share in hot water usage, is an important matter. These systems are commonly known as wastewater heat recovery systems (Salama & Sharqawy, 2020).

Heat recovery systems can be categorized into two main categories. In the first system, the energy from wastewater is transferred to a tank to be used later. The second system involves immediate utilization of the energy from wastewater. These systems are grouped based on the heat exchangers used, which are commonly referred to as gravity film (vertical), horizontal, and shower types. When considering factors such as efficiency, fouling potential, maintenance costs, ease of installation, and other parameters, the gravity film type is often considered the most effective among different designs (McNabola & Shields, 2013).

Wallin and Claesson (Wallin & Claesson, 2014), conducted a research on the performance of a hybrid heat pump system using a gravity film heat exchanger-based Drain Water Heat Recovery (DWHR) system for different flow rates. They utilized the results obtained from experimental studies to examine the theoretical sizing of the heat pump and the impact of the capacity of the storage tank on system performance. During the study, they used wastewater flow rates from different buildings and different time periods. The results of the study showed that with proper system sizing, a significant amount of heat recovery from wastewater can be achieved. The capacity increase of the heat pump has resulted in an approximate 120% increase in system performance. However, the increase in storage tank capacity has led to an approximate 13% improvement in system performance. They also highlighted the effectiveness of using a heat pump with these systems and the performance of the heat pump is a more critical parameter than the tank storage capacity.

Torras et al. (Torras et al., 2016), conducted a study to investigate the performance of a storage-based DWHR system as transient steady state. They emphasized that the temperature distribution of water in the storage tank varying at different times is an important aspect to investigate. The study was conducted in two stages, numerical and experimental, to investigate this problem. It has been said that the water used from the storage device is due to domestic washing processes. Regarding heat losses, they determined that about 50% of the energy was lost within a 24-hour time period inside the tank, and differences in temperature at various locations were not significant. They concluded that the maximum heat recovery occurred at low mass flow rates for different tank temperatures. The research achieved energy recovery between approximately 34% and 60% for the studied flow rates. They also presented that numerical and experimental results were in agreement, and the dimensionless temperature inside the tank and pipes showed a similar trend over time.

Manouchehri and Collins (Manouchehri & Collins, 2016), conducted an experimental investigation into the effect of the inlet water temperature on the performance of the DWHR system. Within the scope of the study, they manufactured four different gravity film heat exchangers with two different diameters and lengths. It was determined that the system efficiency increases with an increase in the inlet temperature of the heat exchanger. It has been determined that an increase in the hot water temperature results in an approximate 3% to 7% improvement in the efficiency of the heat exchanger. It was stated that an increase in temperature and efficiency is influenced by the dynamic viscosity as an effective parameter. In the experimental studies conducted with different geometries, it was found that evaporation losses, transmission losses, and heat losses due to conduction and convection did not have a significant impact on the system performance. They derived a semi-empirical equation to predict the system's efficiency between 5°C and 30°C for cold water and between 25°C and 45°C for hot water.

Garcia (Garcia, 2016), modeled the a thermal resistance network for the transition of hot water and cold water in the gravity film heat exchanger of the DWHR system. The model was validated based on experimental results with an approximate error of about 10%. Furthermore, the study examined the effects of the number of turns in the heat exchanger on system efficiency and pressure drop. It was determined that an increase in the number of turns (2, 4, and 6) led to a decrease in pressure drop and consequently a decrease in system efficiency. Additionally, by investigating system efficiency with different diameter sizes (0.05, 0.08, and 0.10), it was demonstrated that larger diameter sizes resulted in higher system efficiency.

Salama and Sharqawy (Salama & Sharqawy, 2020), conducted some experimental investigations on the heat exchanger surface in the DWHR system under conditions of partial and full wetting, as well as different water flow rates (0.75 gpm-3.75 gpm). The thermal effectiveness of the heat exchanger in the system was determined experimentally and compared to its theoretical value. Additionally, by determining the thermal resistance, improvements were made in heat transfer by reducing the highest resistance. For fully wetted surfaces, it was found that the effectiveness value ranged from 29% to 57%. It was determined that effectiveness increased as the water flow rate decreased due to an increase in the NTU value. For partially wetted surfaces, the effectiveness value ranged from 21% to

42%. When considering that this condition is closest to real-world applications, it is necessary to improve designs to ensure full wetting of the surface. Finally, an empirical correlation for the dimensionless gravity film heat transfer coefficient was obtained from experimental data for the fully wetted surface and the tested DWHR system.

Wang et al. (Wang et al., 2013), designed a simple and effective MFHP (Medium-Temperature Heat Pump) system for recovering energy from low-temperature wastewater. The system consists of a hot water tank and a heat pump cycle without the need for a valve. They emphasized that this feature makes the system both practical and prevents refrigerant leakage, unlike other systems. The design was intended for use in the summer for hot water demand and air conditioning processes. In experimental studies, the COP (Coefficient of Performance) value varied between 3.69 and 5.70. This indicates the effectiveness of the system design in terms of energy performance. They found that it provided approximately a 20% improvement in system performance compared to an original air-source heat pump. They also noted that since the design was tailored for a warm climate region, different design improvements would be necessary for cold climate regions.

Dong et al. (Dong et al., 2015), designed an innovative heat pump system to increase the utilization of energy from water discarded after showering. In this system, they achieved preheating of water by recovering a portion of the waste heat before sending it to the heat pump system. Detailed experimental data were collected during the study. With the new preheating design, the water's temperature increased by approximately 8.3°C. Additionally, the system's performance value increased from 2.19 to 3.21. They observed that as the shower water temperature used in the system increased, energy consumption also increased, leading to a decrease in the COP value from 3.41 to 2.95. Compared to conventional electric heaters, the system demonstrated approximately a 70% energy savings with the heat pump and the new design.

Wu et al. (Wu et al., 2018), conducted thermodynamic analyses for scenarios where sewage water temperature is low, the heat transfer area is insufficient, and the instant water heating relies solely on the heat pump. They performed simulations and analyses for different operating conditions to evaluate energy efficiency and hot water yield. They found that if the evaporator's heat transfer area is limited to 0.5 m<sup>2</sup>, the system performance would reach up to a value of 3.3 for all instant water inlet temperatures, remaining constant under all conditions. It was observed that a decrease in the compressor's suction pressure increased the hot water temperature but had a negative impact on the system's COP value. As the compressor's discharge pressure increased, the hot water outlet temperature also increased. It was determined that an increase in the evaporator's heat transfer surface area resulted in higher hot water output and energy efficiency for the system.

Ramadan et al. (Ramadan et al., 2018), conducted experimental investigations on three different system designs to enhance the efficiency of air-to-air heat pump systems. These systems involved sending wastewater to the condenser, sending wastewater to the evaporator, and sending wastewater to both the evaporator and condenser. Additionally, parametric analyses were carried out for different air temperatures and flow rates. When the wastewater temperature increased from 20°C to 50°C, the COP values of the C-DWHRs, E-DWHRs, and M-DWHRs systems were measured to increase by 19% to 16%, 34% to 174%, and 112% to 411%, respectively. It was also determined that these systems provided economic gains and environmental benefits. As a result, they found that the most effective system was the M-DWHRs.

Khanlari et al. (Khanlari et al., 2020), investigated the shared use of a heat pump system and a water heater for utilizing water discarded in buildings as a heat source in residential heat pump systems. The main objective of the study was to analyze the reuse of waste heat expelled from the building and its impact on the heat pump's performance due to the wastewater temperature. They found that the waste heat expelled from the building increased the system's COP value, and increasing the wastewater temperature from 15°C to 33°C resulted in an approximately 55% improvement in the heat pump's performance. They observed that the system's COP value ranged from 2.91 to 4.58. As a result, the experimental results demonstrated the effectiveness of using wastewater as a heat source in the heat pump system.

This study theoretically investigates the use of a GFHE (Gravity Film Heat Exchanger) for the recovery of waste heat from wastewater, as compared to the use of a heat pump and electric heater without waste heat recovery. It investigates COP, the heat transfer rates and energy consumption for different flow rates and shower water temperatures. A comparison is made among three different designs to highlight the impact of using GFHE.

## Abbreviations

---

GFHE	Gravity Film Heat Exchanger
COP	System Performance
DWHRs	Drain Water Heat Recovery System
$\varepsilon$	Effectiveness
$\dot{W}_{el}$	Electrical Energy Consumption (kW)
T	Temperature (°C)
$\dot{Q}_{ph}$	Preheating Load (kW)

$\dot{Q}_h$	Heat Load (kW)
$\dot{Q}_t$	Total Heat (kW)
$\dot{m}$	Mass flow rate of M-1 and M-2 (kg/s)
$\dot{m}_{hp}$	Mass flow rate of Heat Pump (M-3) (kg/s)
$\dot{W}_c$	Energy Consumption of Heat Pump (kW)
$\dot{V}_{sewage}$	Volume Flow rate (lt/min)

## 2. Material and Methods

The systems commonly used to obtain hot shower water are electric heaters, combi boilers, and heat pump systems. In these systems, reducing energy consumption is of great importance. In this regard, preheating the sewage water using the heat from wastewater can reduce energy consumption in the systems used to obtain hot shower water. Literature studies have shown that effective recovery of wastewater heat is achieved with a vertically positioned Drain Water Heat Exchanger (DWHE). In the study, three different systems have been identified: obtaining hot water with an electric heater (M-1), obtaining hot water with GFX-electric heater (M-2), and obtaining hot water with GFX-heat pump (M-3).

### 2.1. System Designs and Mathematical Equations

In the study, a counterflow GFHE (Gravity Film Heat Exchanger) positioned vertically was utilized for the recovery of waste heat from wastewater. In these heat exchangers, the movement of water is facilitated without the need for any pumps, thanks to the force of gravity, due to their vertical orientation. The heat exchanger consists of pipes with different diameters coiled around a central tube. Waste water entering the vertically positioned heat exchanger transfers its energy to the sewage water entering the coiled pipe from the bottom. As the waste water exits from the bottom, losing heat, the sewage water exits from the upper part, gaining heat. A schematic representation of the GFHE is given in Figure 1.

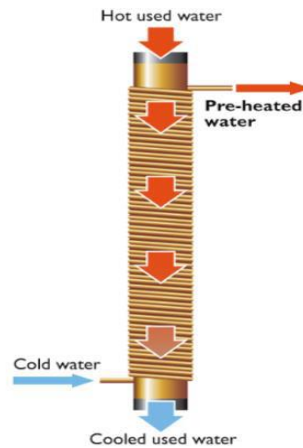


Figure 1. Schematic representation of GFHE [14]

In the research conducted by Zaloum et al., it was demonstrated that the heat exchanger in the GFX-40 model exhibits more effective characteristics in various parameters (Zaloum et al., 2007). Accordingly, in the scope of this study, the GFX-40 heat exchanger was used for the DWHE. Empirical equations for the effectiveness value and NTU (Number of Transfer Units) values obtained from experimental studies of this heat exchanger are given in Equations 1 and 2 (Zaloum et al., 2007).

$$\varepsilon = 1.249\dot{v}^{-0.4328} \tag{1}$$

$$NTU = 3.7669\dot{v}^{-0.6452} \tag{2}$$

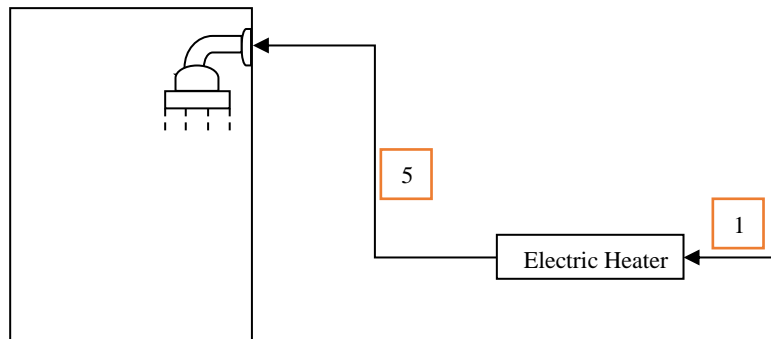
Since only the inlet temperatures and flow rates are known for GFHE, the NTU- $\varepsilon$  method was used for the analysis. Using the effectiveness and NTU values obtained from the empirical equations from the referenced study, the outlet temperatures of the heat exchanger were determined. The equations used for GFHE analysis are provided in Table 1.

Table 1. Equations used for heat exchanger analysis

Hot flow	$\dot{Q} = C_h(T_{hi} - T_{ho})$
Cold flow	$\dot{Q} = C_c(T_{ci} - T_{co})$
Effectiveness	$\varepsilon = \dot{Q} / \dot{Q}_{max}$
Maximum Heat Transfer	$\dot{Q}_{max} = C_{min}(T_{hi} - T_{ci})$

In the designed type 1 model (M-1) as shown in Figure 2, an electric heater is used to increase the temperature of the water (1) obtained from the water supply line to the desired level. The water, after reaching the desired temperature (5), is sent to the bath faucet for showering. The required power to increase the sewage water to the desired temperature is calculated using Equation 3. Since the electric heaters have a system performance of  $\dot{W}_{el} = \dot{Q}_h$ , it is always equal

$$\dot{W}_{el} = \dot{m}c_p(T_5 - T_1) \tag{3}$$

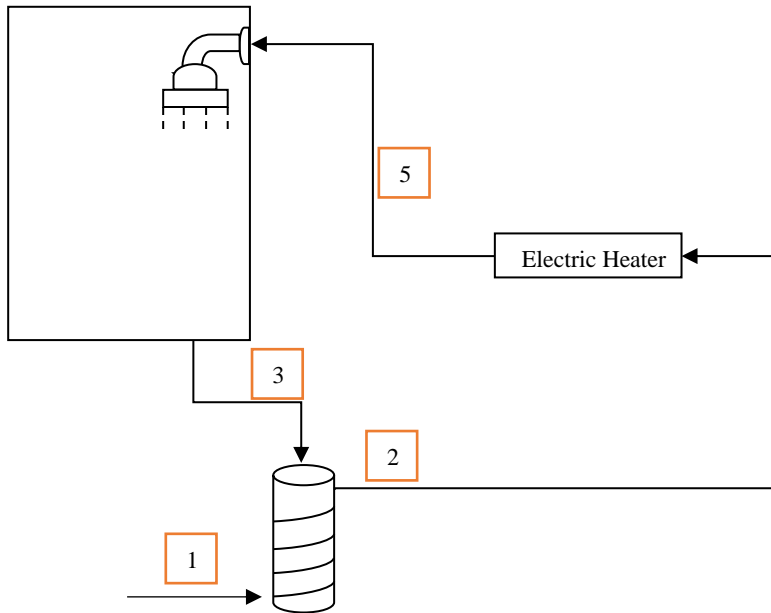


**Figure 2.** Obtaining hot water with an electric heater (M-1)

In the designed type 2 model (M-2) as shown in Figure 3, a preheating process has been implemented on the water obtained from the water supply line (1) before entering the electric heater. The preheating process is carried out using GFHE (Gravity Film Heat Exchanger). The preheated water exiting from GFHE (2) enters the electric heater to achieve the desired shower temperature (5). The hot water source used in the preheating process is the water discharged from the shower (3), which transfers its heat to the water coming from the water supply line through GFHE. Using the equations provided in Table 1 for GFHE, the temperature of the water from the water supply line after preheating (2) was determined. The required power to achieve the desired shower temperature is calculated using Equation 4, and the system's performance value is calculated using Equation 5.

$$\dot{W}_{el} = \dot{m}c_p(T_5 - T_2) \tag{4}$$

$$COP = (\dot{Q}_{ph} + \dot{Q}_h) / \dot{W}_{el} \tag{5}$$



**Figure 3.** Obtaining hot water with GFHE-electric heater (M-2)

In the designed type 3 model (M-3) as shown in Figure 4, a preheating process has been implemented on the water obtained from the water supply line (1) before entering the electric heater. The preheating process is carried out using GFHE (Gravity Film Heat Exchanger). The preheated water exiting GFHE (2) enters the heat pump's condenser as a secondary fluid to achieve the desired shower temperature (5). The hot water source used in the preheating process is the water discharged from the shower (3), which transfers its heat to the water coming from the water supply line through GFHE. The heat pump system is used to achieve the desired shower temperature. The heat pump consists of an evaporator, compressor, condenser, and expansion valve. Using the equations provided in



**Table 2.** Properties of the fluids

	<b>Water</b>	<b>R-314a</b>
<b>Critical Temperature (K)</b>	647.1	374.21
<b>Critical Pressure (bar)</b>	22.064	4.095
<b>Boiling Temperature (K)</b>	373.12	247.08
<b>Specific heat (kJ/kg.K)</b>	4.19	-
<b>Heat conductivity coefficient (W/m.K)</b>	0.65	-

### 3. Results

The study primarily aimed to compare the impact of GFHE usage. For this purpose, three different system designs were created. For each system, the sewage water flow rate, temperature, and shower water temperatures were investigated at equivalent input conditions. Based on the inlet conditions for GFHE, the outlet conditions were determined using the results from experimental studies in the literature. As a result of thermodynamic analysis, the parameters investigated for different flow rates and shower water temperatures are the heat transferred to water, the energy consumption of the system, the effectiveness value for GFHE, and the COP value of the system.

**Table 3.** Inputs and results for Model 1

$\dot{V}_{\text{sewage}}$ (lt/min)	$T_5$ (°C)	$\dot{W}_{\text{el}}$ (kW)	$\dot{Q}_h$ (kW)	COP
6,5	37	13,19	13,19	1
6,5	41	15,01	15,01	1
6,5	45	16,83	16,83	1
8,5	37	17,25	17,25	1
8,5	41	19,63	19,63	1
8,5	45	22,01	22,01	1
10,5	37	21,31	21,31	1
10,5	41	24,25	24,25	1
10,5	45	27,19	27,19	1

Table 3 shows the values of the energy consumption ( $\dot{W}_{\text{el}}$ ) and the energy transferred to water ( $\dot{Q}_h$ ) to raise the sewage water temperature to the desired shower water temperature with an electric heater. It can be seen that the COP value within the electric heater system is 1. Figure 5 illustrates the percentage change in energy consumption for different flow rates and shower water temperatures. It is determined that as the shower temperature decreases, energy consumption decreases by about 24% to 36%, and similarly, as the sewage water flow rate decreases, energy consumption decreases by about 12% to 14%.

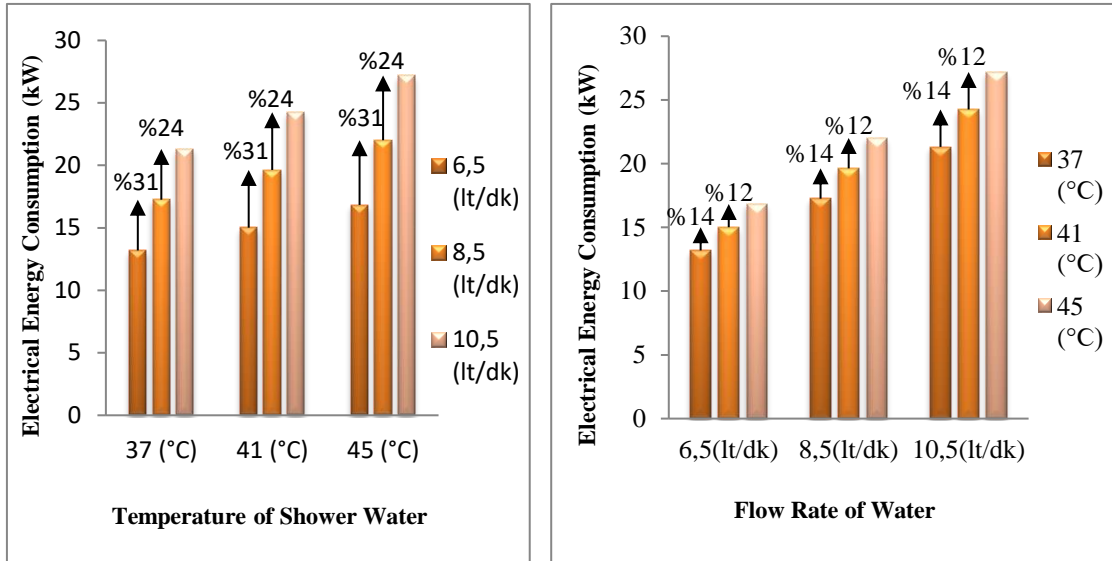


Figure 5. Percentage change in energy consumption of the M-1 based on sewage water flow rate and shower water temperature

Table 4. Inputs and results for Model 2

$\dot{V}_{\text{sewage}}$ (lt/min)	$T_5$ (°C)	$\epsilon$	$\dot{Q}_{\text{ph}}$ (kW)	$\dot{W}_{\text{el}}$ (kW)	$\dot{Q}_{\text{h}}$ (kW)	$\dot{Q}_{\text{t}}$ (kW)	COP
6,5	37	0,52	6,46	6,71	6,71	13,17	1,96
6,5	41	0,52	6,92	8,06	8,06	14,98	1,86
6,5	45	0,52	7,03	9,77	9,77	16,8	1,72
8,5	37	0,48	7,76	9,46	9,46	17,22	1,82
8,5	41	0,48	8,32	11,28	11,28	19,6	1,74
8,5	45	0,48	8,44	13,54	13,54	21,98	1,62
10,5	37	0,45	8,91	12,36	12,36	21,27	1,72
10,5	41	0,45	9,56	14,66	14,66	24,22	1,65
10,5	45	0,45	9,7	17,45	17,45	27,15	1,56

Table 4 provides the values of the energy consumption ( $\dot{W}_{\text{el}}$ ), the heat provided by GFHE in preheating the sewage water ( $\dot{Q}_{\text{ph}}$ ), GFHE effectiveness value, the total energy transferred to water ( $\dot{Q}_{\text{t}}$ ), and COP values to raise the sewage water temperature to the desired shower water temperature with an electric heater-GFHE (M-2). It can be observed that the COP value ranges from a minimum of 1.56 to a maximum of 1.96. It was determined that the effectiveness value decreases with an increase in sewage water flow rate. Figure 6 illustrates the percentage change in energy consumption for different flow rates and shower water temperatures. As the shower temperature decreases, energy consumption decreases by about 30% to 40%, and similarly, as the sewage water flow rate decreases, energy consumption decreases by about 19% to 20%.



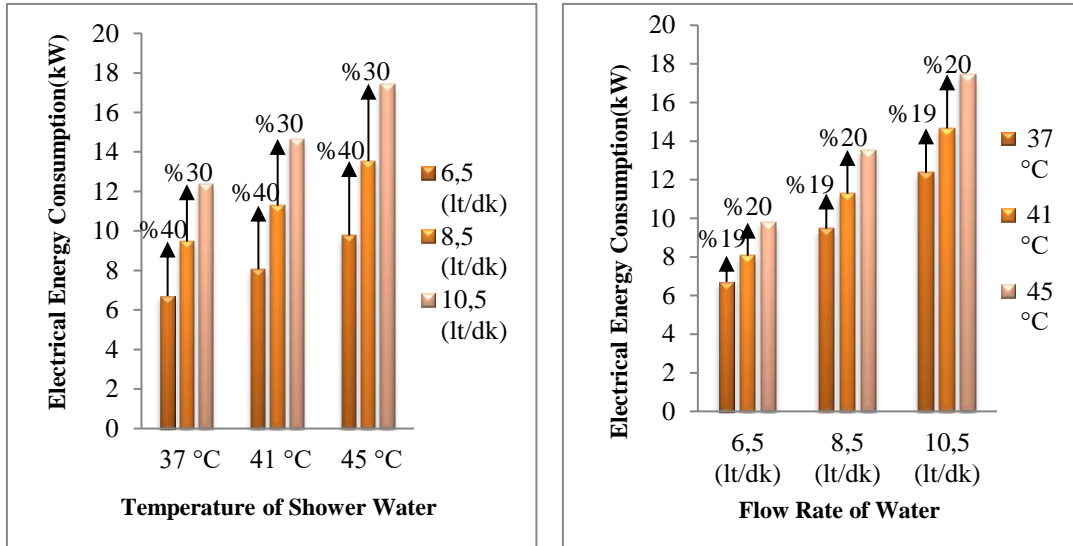
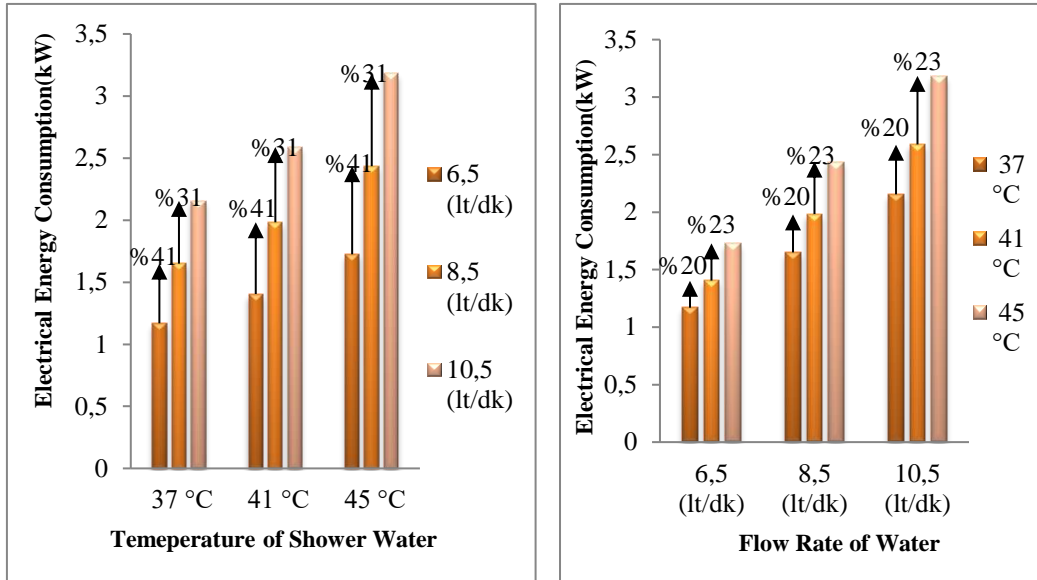


Figure 6. Percentage change in energy consumption of M-2 based on sewage water flow rate and shower water temperature

Table 5. Inputs and results for Model 3

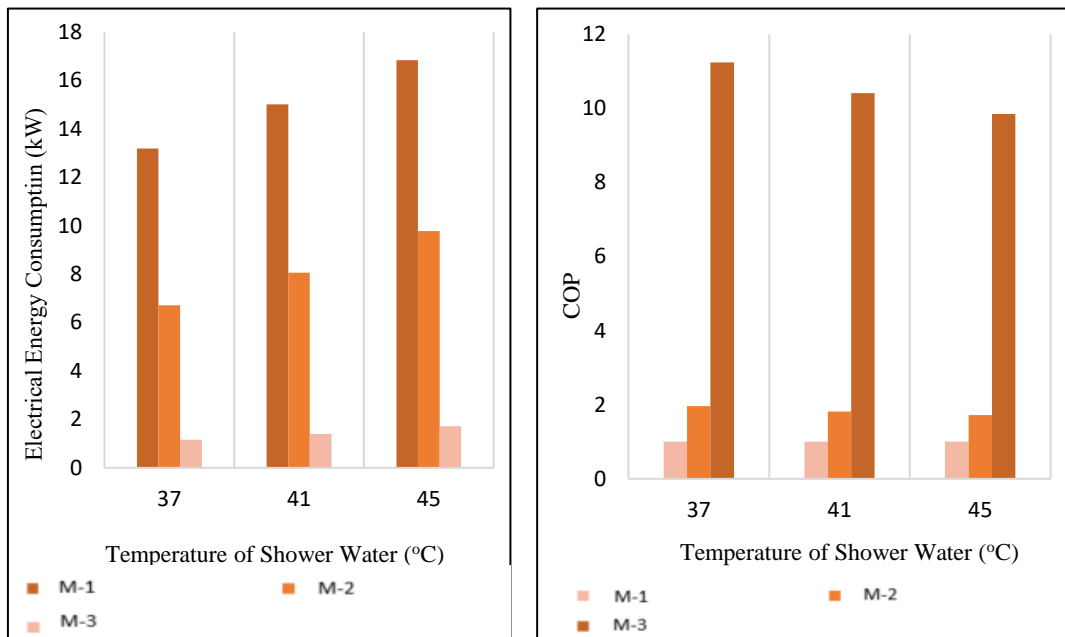
$\dot{V}_{\text{sewage}}$ (lt/min)	$T_5$ (°C)	$\epsilon$	$\dot{Q}_{\text{ph}}$ (kW)	$\dot{Q}_{\text{h}}$ (kW)	$\dot{W}_c$ (kW)	$\dot{Q}_t$ (kW)	COP
6,5	37	0,52	6,46	6,68	1,16	13,14	11,24
6,5	41	0,52	6,92	8,03	1,40	14,95	10,64
6,5	45	0,52	7,03	9,85	1,72	16,88	9,78
8,5	37	0,48	7,76	9,43	1,67	17,19	10,41
8,5	41	0,48	8,32	11,24	1,96	19,56	9,94
8,5	45	0,48	8,44	13,49	2,36	21,93	9,29
10,5	37	0,45	8,91	12,32	2,155	21,23	9,85
10,5	41	0,45	9,56	14,6	2,55	24,16	9,45
10,5	45	0,45	9,7	17,39	3,04	27,09	8,90

Table 5 provides the values of the energy spent ( $\dot{W}_c$ ), the heat provided by GFHE in preheating the sewage water ( $\dot{Q}_{\text{ph}}$ ), GFHE effectiveness value, the total energy transferred to water ( $\dot{Q}_t$ ), and COP values to raise the sewage water temperature to the desired shower water temperature with a heat pump-GFHE (M-3). It can be observed that the COP value ranges from a minimum of 8.90 to a maximum of 11.24. It was determined that the effectiveness value decreases with an increase in sewage water flow rate. Figure 7 illustrates the percentage change in energy consumption for different flow rates and shower water temperatures. As the shower temperature decreases, energy consumption decreases by about 31% to 41%, and similarly, as the sewage water flow rate decreases, energy consumption decreases by about 20% to 23%.

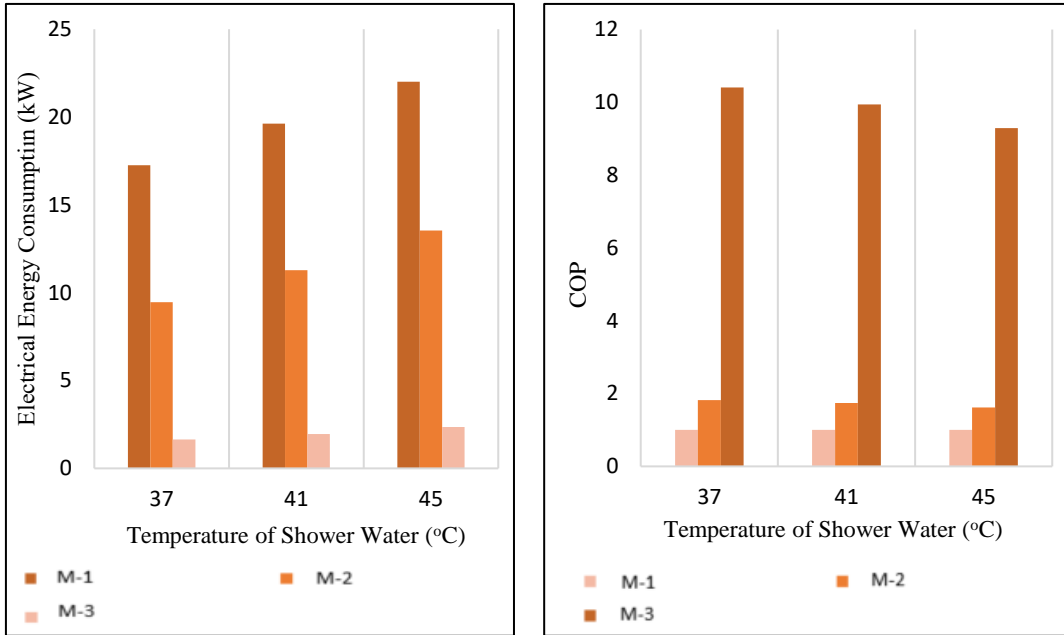


**Figure 7.** Percentage change in energy consumption for M-3 system based on sewage water flow rate and shower water temperature

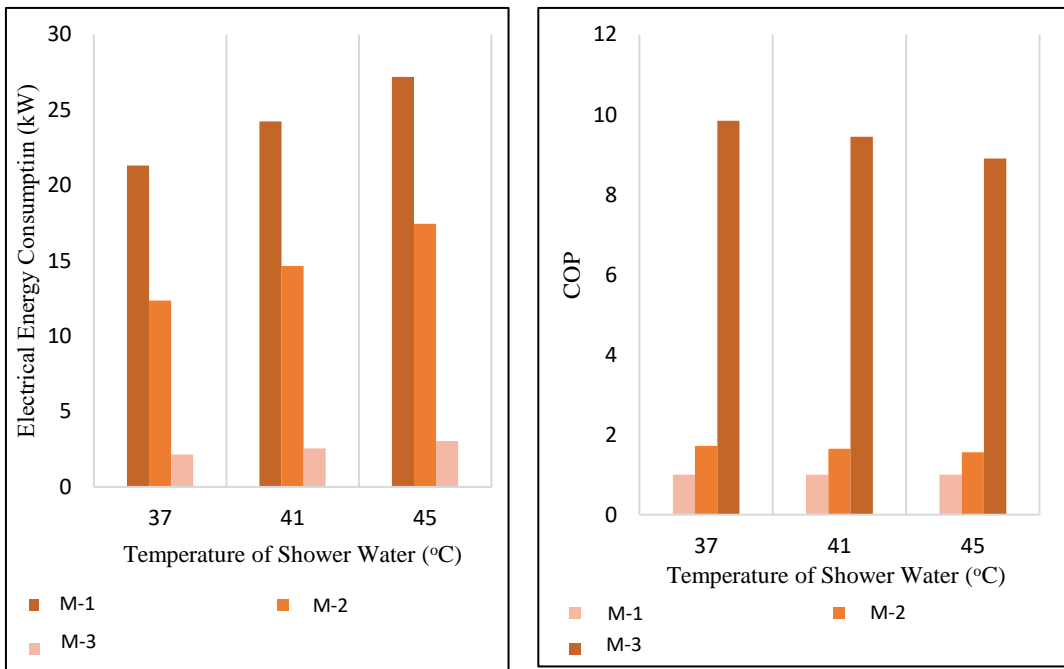
The energy consumption and COP values for the three different systems based on sewage water flow rate are shown in Figures 8, 9, and 10. For all flow rates, as the shower water temperature increases, energy consumption increases, leading to a decrease in the overall COP of the system. For a flow rate of 6.5 lt/min, energy consumption for hot water production has decreased by approximately 41-49% for systems M-2 and 89-91% for M-3 compared to the electric heater. In contrast, COP values have increased by a factor of approximately 1.72-1.96 for M-2 and 9.78-11.24 for M-3. For a flow rate of 8.5 lt/min, energy consumption for hot water production has decreased by approximately 38-45% for systems M-2 and 89-90% for M-3 compared to the electric heater. COP values have increased by a factor of approximately 1.62-1.82 for M-2 and 9.29-10.41 for M-3. For a flow rate of 10.5 lt/min, energy consumption for hot water production has decreased by approximately 35-42% for systems M-2 and 88-89% for M-3 compared to the electric heater. COP values have increased by a factor of approximately 1.56-1.72 for M-2 and 8.9-9.85 for M-3.



**Figure 8.** Comparison of energy consumption and COP values based on shower water temperature for a sewage water flow rate of 6.5 lt/min.



**Figure 9.** Comparison of energy consumption and COP values based on shower water temperature for a sewage water flow rate of 8.5 lt/min



**Figure 10.** Comparison of energy consumption and COP values based on shower water temperature for a sewage water flow rate of 10.5 lt/min.

#### 4. Conclusion

In the study, three different system designs were developed for the production of hot water for showers. The main focus of the study was to investigate the contribution of GFHE to the system. Analytical solutions were obtained for each system using energy balance equations and experimental relationships for GFHE in the respective systems. The amount of energy consumed was used as a parameter for comparing the systems. The general findings obtained in the study are summarized below.

- When hot water production is provided by an electric heater (M-1), the energy consumption value has been the highest among the system designs. This is because the amount of energy supplied by the electric heater is the same as the consumption. Since no preheating process is applied to the water coming from the pipeline, the energy consumption value has been higher.
- When hot water production is provided by an electric heater-GFHE (M-2), the water has been preheated with GFHE. In this case, it has reduced the consumption of electrical energy to achieve the desired shower water temperature. Overall, when

looking at the performance of a system, a significant portion of the energy used to heat the water is provided by GFHE compared to the M-1 system.

- To further increase efficiency in hot water production, the use of environmentally friendly heat pump-GFHE (M-3) has resulted in the lowest energy consumption values. The effective COP values of heat pumps and the preheating of water with GFHE have improved the efficiency of the M-3 system. Compared to other systems, the system's COP value increasing by approximately 8.9-11.24 times indicates that it is an effective design.
- It has been determined that when the shower water and sewage water flow rates decrease, the energy consumption values generally decrease by approximately 12-41%.
- It has been observed that preheating water with GFHE in the systems is an effective solution. With the increasing flow rate, the decrease in efficiency has increased the energy consumption required to raise the water to the desired temperature.

In the study, it is observed that initially heating the water in the system during shower use and then starting the preheating process with GFHE and waste heat is not an ideal situation. This leads to a decrease in the actual system efficiencies. Since continuous shower usage is not assumed in the study, future research should consider storing and utilizing water in a tank. Additionally, designs aimed at increasing the effectiveness of GFHE in the system and conducting cost analyses are necessary for further investigations.

## 5. References

- Adhikari, P. (2017). Feasibility study of waste heat recovery from laundry facility Case study : Mr Washing Man Oy. Helsinki Metropolia University.
- Defra Report. (2008). Measurement of Domestic Hot Water Consumption in Dwellings.
- Dong, J., Zhang, Z., Yao, Y., Jiang, Y., & Lei, B. (2015). Experimental performance evaluation of a novel heat pump water heater assisted with shower drain water. *Applied Energy*, 154, 842–850. <https://doi.org/10.1016/j.apenergy.2015.05.044>
- Dubey, A. M., Kumar, S., & Agrawal, G. Das. (2014). Thermodynamic analysis of a transcritical CO<sub>2</sub>/propylene (R744-R1270) cascade system for cooling and heating applications. *Energy Conversion and Management*, 86, 774–783. <https://doi.org/10.1016/j.enconman.2014.05.105>
- Garcia, J. D. (2016). Characterization of greywater heat exchangers and the potential of implementation for energy savings [Kungliga Tekniska Högskolan]. <https://doi.org/10.1051/e3sconf/20184500034>
- Getu, H. M., & Bansal, P. K. (2008). Thermodynamic analysis of an R744-R717 cascade refrigeration system. *International Journal of Refrigeration*, 31(1), 45–54. <https://doi.org/10.1016/j.ijrefrig.2007.06.014>
- Gholamian, E., Hanafizadeh, P., & Ahmadi, P. (2018). Advanced exergy analysis of a carbon dioxide ammonia cascade refrigeration system. *Applied Thermal Engineering*, 137(March), 689–699. <https://doi.org/10.1016/j.applthermaleng.2018.03.055>
- Jain, V., Kachhwaha, S. S., & Sachdeva, G. (2013). Thermodynamic performance analysis of a vapor compression-absorption cascaded refrigeration system. *Energy Conversion and Management*, 75, 685–700. <https://doi.org/10.1016/j.enconman.2013.08.024>
- Khanlari, A., Sözen, A., Sahin, B., Di Nicola, G., & Afshari, F. (2020). Experimental investigation on using building shower drain water as a heat source for heat pump systems. *Energy Sources, Part A: Recovery, Utilization and Environmental Effects*, 00(00), 1–13. <https://doi.org/10.1080/15567036.2020.1796845>
- Klein, S. A. (2012). Engineering Equaiton Solver(EES) (9.0; p. 9.0). F-Chart Software.
- Manouchehri, R., & Collins, M. R. (2016). An experimental analysis of the impact of temperature on falling film drain water heat recovery system effectiveness. *Energy and Buildings*, 130(April), 1–7. <https://doi.org/10.1016/j.enbuild.2016.08.031>
- McNabola, A., & Shields, K. (2013). Efficient drain water heat recovery in horizontal domestic shower drains. *Energy and Buildings*, 59, 44–49. <https://doi.org/10.1016/j.enbuild.2012.12.026>
- Ramadan, M., Murr, R., Khaled, M., & Olabi, A. G. (2018). Mixed numerical - Experimental approach to enhance the heat pump performance by drain water heat recovery. *Energy*, 149, 1010–1021. <https://doi.org/10.1016/j.energy.2018.01.086>
- Salama, M., & Sharqawy, M. H. (2020). Experimental investigation of the performance of a falling-film drain water heat recovery system. *Applied Thermal Engineering*, 179(February), 115712. <https://doi.org/10.1016/j.applthermaleng.2020.115712>

- Torras, S., Oliet, C., Rigola, J., & Oliva, A. (2016). Drain water heat recovery storage-type unit for residential housing. *Applied Thermal Engineering*, 103, 670–683. <https://doi.org/10.1016/j.applthermaleng.2016.04.086>
- Wallin, J., & Claesson, J. (2014). Analyzing the efficiency of a heat pump assisted drain water heat recovery system that uses a vertical inline heat exchanger. *Sustainable Energy Technologies and Assessments*, 8, 109–119. <https://doi.org/10.1016/j.seta.2014.08.003>
- Wang, H., Wang, Q., & Chen, G. (2013). Experimental performance analysis of an improved multifunctional heat pump system. *Energy and Buildings*, 62, 581–589. <https://doi.org/10.1016/j.enbuild.2013.04.001>
- Wu, Y., Jiang, Y., Gao, B., Liu, Z., & Liu, J. (2018). Thermodynamic analysis on an instantaneous water heating system of shower wastewater source heat pump. *Journal of Water Reuse and Desalination*, 8(3), 404–411. <https://doi.org/10.2166/wrd.2017.194>
- Yao, R., & Steemers, K. (2005). A method of formulating energy load profile for domestic buildings in the UK. *Energy and Buildings*, 37(6), 663–671. <https://doi.org/10.1016/j.enbuild.2004.09.007>
- Zaloum, C., Lafrance, M., & Gusdorf, J. (2007). Drain Water Heat Recovery Characterization and Modeling. In *Sustainable Buildings and Communities*. [http://www.gfxtechnology.com/NRCAN-6\\_29\\_07.pdf](http://www.gfxtechnology.com/NRCAN-6_29_07.pdf)