

3 Serbestlik Dereceli Sistemin Yapay Zekâ Tabanlı LQR ve PID Kontrolcü Tasarımı

Engin Hasan ÇOPUR ^{1*}  Hasan Hüseyin BİLGİÇ ²  Tarık ÜNLER ³ 

¹ Necmettin Erbakan University, Faculty of Aeronautics and Astronautics, Department of Aerospace Engineering, Konya, Türkiye

² Necmettin Erbakan University, Faculty of Aeronautics and Astronautics, Department of Aeronautical Engineering, Konya, Türkiye

³ Necmettin Erbakan University, Faculty of Aeronautics and Astronautics, Department of Avionics, Konya, Türkiye

Makale Bilgisi

ÖZET

Geliş Tarihi: 16.02.2024
Kabul Tarihi: 28.05.2024
Yayın Tarihi: 31.12.2024

Anahtar Kelimeler:

Tepe Vinci,
Yapay Zekâ
LQR,
PID,
Yapay Arı Kolonisi
Algoritması.

Bu çalışmada 3 serbestlik dereceli eksik eyleyicili bir sistemin konum kontrolü gerçekleştirilmiştir. Geliştirilen yaklaşım ikili sarkaç tipi tepe vincinin üzerinde denenmiştir. İlk olarak sistemin matematiksel modeli doğrusal olmayan dinamikler dikkate alınarak Euler-Lagrange metodu ile elde edilmiştir. Benzetim çalışmalarında PID ve LQR kontrolcileri kullanıldığından doğrusal olmayan model sistemin denge noktası etrafında doğrusallaştırılmıştır. Elde edilen doğrusal model kullanılarak PID ve LQR kontrolcülerinin parametreleri Yapay Arı Kolonisi Algoritması ile ayarlanmıştır. Optimizasyon sürecinde sistemin üç serbestliğindeki hatanın minimize edilmesi için geleneksel uygunluk fonksiyonlarından Zamansal mutlak hataların toplamı (Integral Time Absolute Error) fonksiyonu seçilmiştir. Ayrıca arabanın hassas hareketini sağlamak için amaç fonksiyonu birim basamak cevaplarını içerecek şekilde iyileştirilmiştir. Kontrolcü performansları benzetim ortamında yapılan çalışmalar ile denenmiştir. Sonuçlar tablo ve grafikler halinde sunulmuştur. Önerilen yaklaşım çok serbestlik dereceli ve eksik eyleyici sistemlerin kontrolünde kullanılabilir.

Artificial Intelligence based LQR and PID Controller Design of 3 Degree of Freedom System

Article Info

ABSTRACT

Received: 16.02.2024
Accepted: 28.05.2024
Published: 31.12.2024

Keywords:

Gantry crane,
Artificial Intelligence,
LQR,
PID,
Artificial Bee Colony
Algorithm.

In this study, the position control of a 3 DoF underactuated system is carried out. The developed approach is tested on a double pendulum overhead crane. Considering the nonlinear dynamics of the system, its mathematical model is first obtained by Euler-Lagrange model. Then, since PID and LQR controllers are used in the simulations, the nonlinear model is linearized around the equilibrium point of the system. Using the linear model, the parameters of LQR and PID controllers are tuned by Artificial Bee Colony Algorithm. In the optimization process, the Integral Time Absolute Error function is chosen from traditional fitness functions to minimize the error in each single-degree-of-freedom joint of the system. Additionally, to ensure the precise movement of the car, the objective function is improved in a way to include unit step response characteristics. The control performance is evaluated in the simulations. The results are presented in tables and graphs. The proposed approach can be used to control multi-degree of freedom underactuated systems.

To cite this article:

Çopur, E.H.; Bilgiç, H.H. & Ünler, T. (2024). Artificial intelligence based LQR and PID controller design of 3 degree of freedom system. *Necmettin Erbakan University Journal of Science and Engineering*, 6(3), XX- XX. <https://doi.org/10.47112/neufmbd.2024.58>

*Sorumlu Yazar: Engin Hasan Çopur, ehcopur@erbakan.edu.tr



INTRODUCTION

Industrial cranes are frequently used in various stages of production. Transporting especially heavy loads from one place to another in production processes is one of the most important processes of production. The main function of industrial cranes is to transport heavy loads. What is expected from industrial cranes is to transport the loads they carry to a desired location quickly and with as little oscillation as possible. For this reason, different control methods enable the load to be transported from one point to another with minimal oscillation [1].

Oscillations are reduced by using different control approaches. In the control applications of industrial cranes, open- and closed-loop control approaches are frequently used to reduce oscillations. Some well-known examples of open-loop control approaches are input shaping, filter and command smoothing applications [2-4]. The command shaping control method was also used to control a double pendulum crane in an open-loop control architecture [5]. For the closed-loop control applications, PID (Proportional-Integral-Derivative) controllers are usually preferred [6-8]. Apart from this, LQR method was also applied to control crane position [9].

The fine-tuning process is extremely important to satisfy the control performance criteria determined in the design process. Various methods have been utilized to perform the fine-tuning process. For the industrial control applications, there are some traditional control tuning methods such as Ziegler-Nicholas and Cohen-Coon methods. However, these control tuning methods usually struggle to meet the control criteria when a cascade control strategy needs to be implemented in the control applications such as double overhead pendulum crane (DPOC), flight control and inverted pendulum control systems. Therefore, to deal with these complex control problems, some advanced tuning methods must be applied.

Optimization methods have been successfully applied to fine-tune the parameters of different control methods for many years. The behaviours of animals in the nature inspire the researchers to develop effective optimization algorithms for the parameter estimation in the control process so that the estimated parameters are sufficiently accurate to achieve the desired performance [10, 11]. In general, an optimization method searches the required parameters within a pre-defined local space which can minimize an objective function defined by considering the control aims.

Bandong et al. [12] have compared three optimization techniques, namely Particle Swarm Optimization (PSO), Flower Pollination Algorithm (FPA), and Stochastic Fractal Search (SFS), to tune the PID controller parameters in the control of the position and sway angle of the gantry crane. In another study, a 3D crane system was considered, and a PSO based PID-PID control structure, including one outer loop and one inner loop, was built to control the crane without an enormously large swing angle [13]. Genetic Algorithm (GA) is also an alternative optimization approach for tuning PID and LQR parameters in gantry crane control [14-16]. An alternative approach was to use a generalized predictive control (GPC) approach, which is known as a robust-optimal control [17], to tune PID parameters for the control of a 3D crane system [18]. In addition, fuzzy systems are also applied to fine-tune control parameters due to their model independent structure [19].

In this study, both PID and LQR controllers are utilized in a feedback control architecture for the position and anti-swing control of a double pendulum overhead crane (DPOC). DPOC is an underactuated system. In other words, the system has a single actuator and three degrees of freedom. Successful control of the system is possible by fine-tuning the controller gains. The control parameters are fine-tuned by using Artificial Bee Colony (ABC) Algorithm. To the authors' knowledge and based on their literature search, limited research has focused on ABC based PID and LQR controllers for the DPOC system. Therefore, the main aim of this study is to compare the performance of PID and LQR

controllers tuned by ABC algorithm for the position and anti-swing control of DPOC system. In addition, to minimize the performance measure defined in terms of ITAE as well as the overshoot and the settling time, a specific objective function is also proposed. The comparative analysis is performed in a simulation environment, and the results show that LQR provides better control performance than PID.

MATHEMATICAL MODEL OF DPOC

A schematic representation of a DPOC system is given in Figure 1. As seen in Figure 1, this crane mechanism consists of trolley, hook, and payload whose masses are m_t , m_h , and m_p , respectively. The trolley is connected to the hook via a cable of length l_{th} , and the hook is connected to the payload by using another cable of length l_{hp} . In the modelling process, the cables are assumed to be inflexible and massless. The trolley can be moved back and forward on a bridge rail by an actuating force F_{act} to transport the payload to a desired position. During the transportation of the payload, the hook and payload exhibit swinging motions determined by the hook swing angle θ_h and payload swing angle θ_p . Therefore, the main control problem is here to design an effective controller that can suppress these swing angles, thereby stabilizing the payload around the vertical axis passing through the centre of gravity of the trolley.

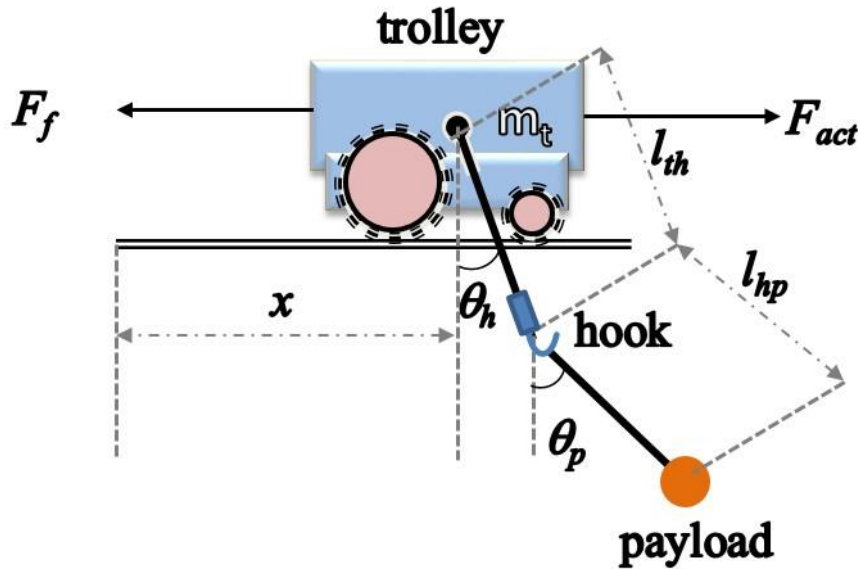

Figure 1
Schematic Representation of a Double Pendulum Overhead Crane

By using Euler-Lagrange method, the equations of motion can be described in a matrix form [20-23] as

$$M(q)\ddot{q} + C(q, \dot{q})\dot{q} + G(q)q = U \quad (1)$$

where $q = [x \ \theta_h \ \theta_p]$, and $M(q)$, $C(q, \dot{q})$, $G(q)$ and U denote respectively the inertia matrix, the centripetal-Coriolis matrix, the gravity vector, and the control input vector. The terms in the mathematical model of the double-pendulum overhead crane can be explicitly written as

$$M(q) = \begin{bmatrix} m_t + m_h + m_p & (m_h + m_p)l_{th} \cos \theta_h & m_p l_{hp} \cos \theta_p \\ (m_h + m_p)l_{th} \cos \theta_h & (m_h + m_p)l_{th}^2 & m_p l_{th} l_{hp} \cos(\theta_h - \theta_p) \\ m_p l_{hp} \cos \theta_p & m_p l_{th} l_{hp} \cos(\theta_h - \theta_p) & m_p l_p^2 \end{bmatrix} \quad (2)$$

$$C(q, \dot{q}) = \begin{bmatrix} 0 & -(m_h + m_p)l_{th}\dot{\theta}_h \sin \theta_h & -m_p l_{hp} \dot{\theta}_p \sin \theta_p \\ 0 & 0 & m_p l_{th} l_{hp} \dot{\theta}_p \sin(\theta_h - \theta_p) \\ 0 & -m_p l_{th} l_{hp} \dot{\theta}_p \sin(\theta_h - \theta_p) & 0 \end{bmatrix} \quad (3)$$

$$G(q) = [0 \quad (m_h + m_p)gl_{th} \sin \theta_h \quad m_p gl_{hp} \sin \theta_p]^\top \quad (4)$$

$$U = [F_{act} - F_f \quad 0 \quad 0]^\top \quad (5)$$

where F_f represents the nonlinear mechanical friction between the trolley and the rail. The friction force can be modelled by

$$F_f(\dot{x}) = f_{r0} \tanh\left(\frac{\dot{x}}{\zeta}\right) - k_r |\dot{x}| \dot{x}$$

where f_{r0} and ζ are the static friction-related coefficients, and k_r is the viscous friction-related coefficient parameter [24]. Additionally, by considering the physical nature of the overhead crane system, the hook swing angle θ_h and the payload swing angle θ_p can be assumed to change within the range of

$$-\frac{\pi}{2} < \theta_p, \theta_h < \frac{\pi}{2}, \forall t \geq 0$$

to solve the control problem of DPOC system, PID and LQR controllers are utilized. Therefore, the nonlinear system model (1) should be linearized around the equilibrium point of the system, i.e. $\theta_h = \mathbf{0}$ and $\theta_p = \mathbf{0}$. Assuming that $\sin \theta_h \cong \theta_h$, $\sin \theta_p \cong \theta_p$, $\cos \theta_h \cong 1$, $\cos \theta_p \cong \theta_p$, $\dot{\theta}_h \cong \mathbf{0}$ and $\dot{\theta}_p \cong \mathbf{0}$, the linear model is obtained in the following form

$$\dot{\tilde{x}} = A\tilde{x} + Bu \quad (6)$$

where $\tilde{x} = [x \quad \theta_h \quad \theta_p \quad \dot{x} \quad \dot{\theta}_h \quad \dot{\theta}_p]$ and $u = F_{act}$. The system and control matrices of the linear system (6) are given as follows:

$$A = \begin{bmatrix} 0_{3 \times 3} & I_{3 \times 3} \\ 0 & a_{42} & 0 & a_{44} & 0 & 0 \\ 0 & a_{52} & a_{53} & a_{54} & 0 & 0 \\ 0 & a_{62} & a_{63} & 0 & 0 & 0 \end{bmatrix} \text{ and } B = \begin{bmatrix} 0_{3 \times 1} \\ b_4 \\ b_5 \\ 0 \end{bmatrix}$$

$$\text{with } a_{42} = g(m_h + m_p)m_t^{-1}, a_{44} = -f_{r0}(\zeta m_t)^{-1}, a_{52} = -g(m_t + m_h)(m_h + m_p)m_t l_{th} l_{hp}, \\ a_{53} = gm_p(l_{th} m_h)^{-1}, a_{54} = f_{r0}(\zeta m_t l_{th})^{-1}, a_{62} = g(m_h + m_p)(m_h l_{hp})^{-1}, a_{63} = \\ -g(m_h + m_p)(m_h l_{hp})^{-1}, b_4 = 1/m_t \text{ and } b_5 = -(m_t l_{th})^{-1}.$$

CONTROLLER DESIGN

The control problem in this study can be stated as follows: given a desired setpoint x_r , compute a controller input F_{act} to move the trolley to x_r while minimizing the swing angles θ_h and θ_p as much as possible. To achieve these control goals, PID and LQR controllers are designed and tested in a simulation environment.

PID Controller

In classical control methods, the main aim is to determine the control input so that the control requirements on the transient response characteristics can be satisfied. In general, these requirements are determined in terms of some constraints on rise time, settling time, maximum overshoot, and steady-state error. PID controller is a well-known classical control methods and still widely used in industrial control applications due to its simple structure and easy implementation.

To compute the required control input in PID based approach, the general form of the control law can be given as

$$u = K_p e + K_i \int_0^t e dt + K_d \frac{de}{dt} \quad (7)$$

where e is the error signal between the reference signal and the output signal of the controlled plant. For the position control of DPOC system, a PID based control architecture is built as shown in Figure 2 where three different controllers are implemented. PID controller in the feedforward path is utilized to move the trolley to the desired setpoint, and thereby attempt to minimize the error between the desired position x_r and the current position x of the trolley. Other controllers in the feedback loops are implemented to eliminate the swing angles θ_h and θ_p . Therefore, the required control input u in (6) is the summation of the control inputs produced by these three controllers.

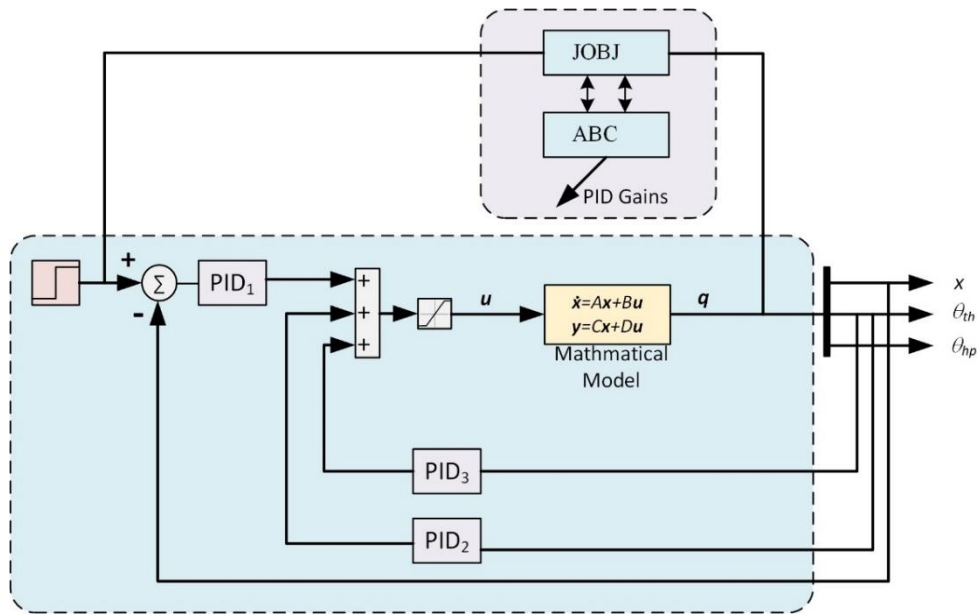

Figure 2
PID Based Control Architecture.

LQR Controller

Unlike classical control methods, optimal control methods in modern control theory are developed to achieve relatively more challenging control performance, as defined by different performance measures. For example, a system may need to move from an initial point to a final point in the minimum time possible while minimizing control effort. Optimal control methods possess the capability to address such control problems.

LQR controller is a type of optimal control methods developed for the plant whose dynamics can be expressed as a linear time-invariant mathematical model. In LQR method, the main goal is to minimize the cost function given by

$$J = \frac{1}{2} \int_{t_0}^{t_f} (\tilde{x}^T Q \tilde{x} + u^T R u) dt$$

subject to $\dot{\tilde{x}} = A\tilde{x} + Bu$ by using a control law in the form of

$$u = -K\tilde{x} \tag{8}$$

where $K = R^{-1}B^T P$ and P is a positive definite matrix that can be determined by solving the algebraic Riccati Equation (ARE)

$$PA + A^T P - PBR^{-1}B^T P + Q = 0$$

In addition, to ensure an asymptotic tracking of a reference signal with zero steady state error, an integral state relating to the trolley position can be introduced. Then, the state vector \tilde{x} becomes $\tilde{e} = [x_e \ \tilde{x}_e]$ where

$$x_e = [x_d - x \ \theta_h \ \theta_p \ \dot{x} \ \dot{\theta}_h \ \dot{\theta}_p]$$

and

$$\tilde{x}_e = \int [x_d - x] dt$$

Then, the model of the error dynamics can be derived as follows:

$$\dot{\tilde{e}} = \tilde{A}\tilde{x} + \tilde{B}u$$

where

$$\tilde{A} = \begin{bmatrix} A & 0 \\ -C & 0 \end{bmatrix} \text{ and } \tilde{B} = \begin{bmatrix} B \\ 0 \end{bmatrix}$$

and the control law (7) can be now computed as

$$u = -\tilde{K}\tilde{e} \tag{9}$$

with $\tilde{K} = R^{-1}\tilde{B}^T\tilde{P}$ where \tilde{P} is the solution of ARE given by

$$\tilde{P}\tilde{A} + \tilde{A}^T\tilde{P} - \tilde{P}\tilde{B}R^{-1}\tilde{B}^T\tilde{P} + Q = 0$$

to control the DPOC system, the designed control architecture including LQR controller is schematically represented in Figure 3.

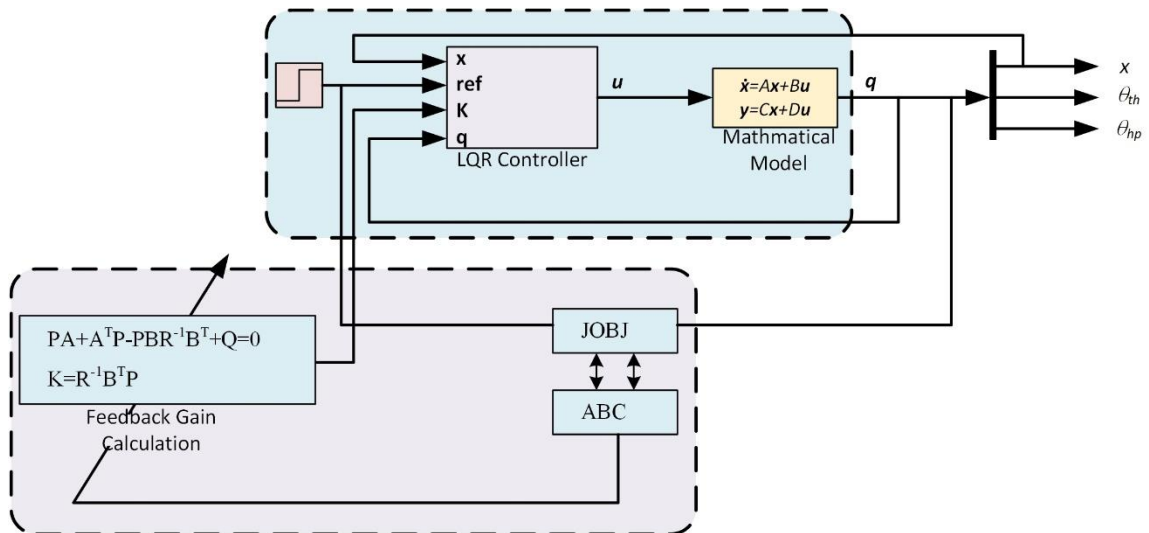

Figure 3
LQR Based Control Architecture

CONTROLLER TUNING METHOD

To fine-tune the control parameters of PID and LQR controllers given in (6) and (8), ABC

optimization method is applied.

ABC Algorithm

The Artificial Bee Colony (ABC) Algorithm, first proposed by Karaboga [25], is used effectively in many engineering fields [26-28]. As in other heuristic algorithms, ABC Algorithm aims to minimize or maximize a specified function. Within the scope of the study, the traditional fitness function, ITAE (Integral Time Absolute Error), presented in Equation 10 was used to minimize errors in the DPOC system.

$$ITAE = \int t|\varepsilon|dt \quad (10)$$

Here, t refers to time and ε refers to error. While all errors are minimized in the system, the trolley must move with minimum errors. For this reason, a new objective function presented in Equation 11 was derived by combining the function written for the movement of the car with the ITAE fitness function.

$$JOBJ = ITAE_x + ITAE_{\theta_h} + ITAE_{\theta_p} + (1 - e^{-\beta})Overshoot_{\theta_p} + e^{-\beta}(ts_{\theta_p} - tr_{\theta_p}) \quad (11)$$

Here, ts and tr represent the settling and rising time of the trolley, respectively. β is the weight coefficient. By reviewing the literature, $\beta = 0.7$ was taken in the study [29]. Table 1 presents the setting parameters, lower and upper bounds, and final values of the LQR and PID controller gains.

Table 1
Optimized Parameter Values

		Before Optimization		After Optimization	
		Lower Bound	Upper Bound	Final Values	
LQR	q1	0	300	217.17	
	q2	0	300	57.18	
	q3	0	300	300	
	q4	0	300	0.0765	
	q5	0	300	299.796	
	q6	0	300	10.15	
	q7	0	300	299.69	
	r	0	300	0.001	
PID Controller	PID 1	kp1	0	300	299.56
		ki1	0	100	2.28
		kd1	0	30	0.99
	PID 2	kp2	0	300	13.07
		ki2	0	100	0.001
		kd2	0	30	2.27
	PID 3	kp3	0	300	299.95
		ki3	0	100	44.49
		kd3	0	30	21.23

RESULTS

A set of simulations is performed to compare the performance of PID and LQR controllers. The control objective is to move the trolley to the desired position, i.e. $x_r = 0.1$ m. The simulations start from the same initial conditions, i.e. $q_0 = [x(0) \ \theta_h(0) \ \theta_p(0)]^T = [0 \ 0 \ 0]^T$. In the simulations, the parameters of the DPOC system are selected from the literature and given in Table 2 [20].

Table 2
Parameter Values Of DPOC System

PARAMETERS	VALUE
Trolley mass, m_t	12 kg
Hook mass, m_h	1.5 kg
Payload mass, m_p	1 kg
Trolley-hook cable, l_{th}	1.2 m
Hook-payload cable, l_{hp}	0.5 m
Static friction-related coefficient 1, f_{r0}	8
Static friction-related coefficient 2, ζ	0.01
Viscous friction-related coefficient, k_r	-1.2

Figure 4 presents the trolley position controlled by PID and LQR approaches. Both controllers can move the trolley to the desired position successfully according to the control criteria. However, there is a significant difference between the performance of LQR and PID controllers in terms of the transient response characteristics, especially settling time. As shown in Figure 4, the trolley reaches the desired position in a smaller settling time by means of LQR controller than PID controller. In addition, both controllers provide a steady state error within acceptable range. Figure 5 and Figure 6 show the swing angles of the hook and payload. Both payload angle and hook angle showed less oscillation when the LQR controller was preferred.

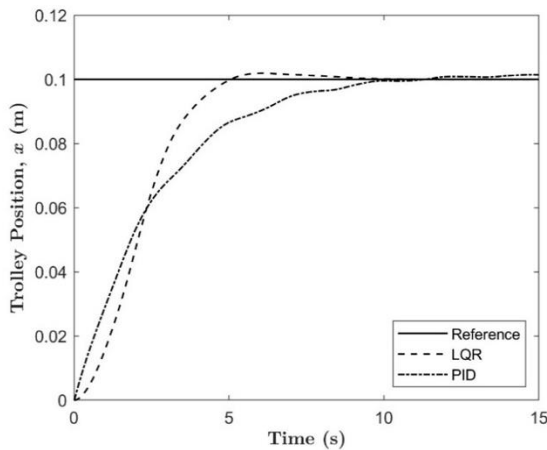

Figure 4
Trolley Position Of DPOC System for PID And LQR Controllers

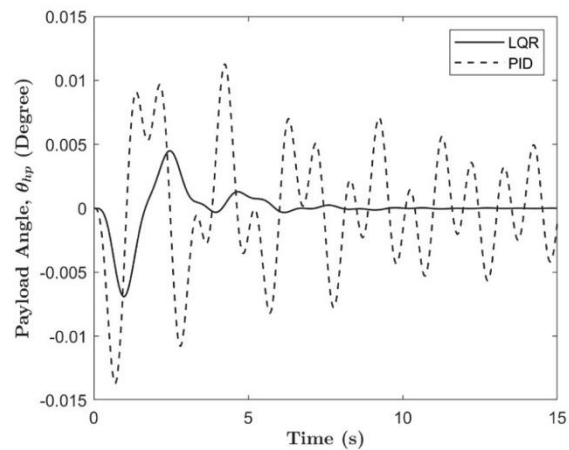

Figure 5
Payload Angle Of DPOC System for PID And Controllers

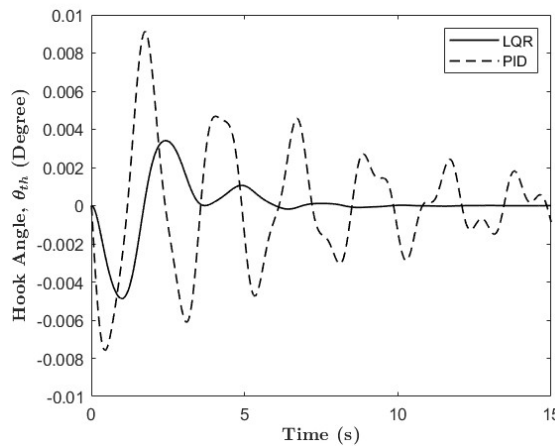

Figure 6
Hook angle of DPOC System for PID and Controllers

CONCLUSION

This study has presented an approach for the position and antiswing control of the DPOC system. The control task is based on moving the trolley to a desired position and minimizing the swing angles of the hook and payload as much as possible. To achieve this control task, PID and LQR control methods are applied to the DPOC system. The control parameters are fine-tuned by using ABC algorithm which utilizes the linear mathematical model of the DPOC system. In the optimization process, a new objection function is derived to minimize ITAE performance measure and improve the performance criteria in time domain. The effectiveness of these tuned controllers is tested in simulation environment. To make a comparative analysis, the control performance characteristics are considered. The settling time and rise time for the position of the trolley are 5.26 s and 8.88 s, respectively for PID controller. On the other hand, the settling time and rise time for the position of the trolley are 2.98 s and 6.11 s, respectively for LQR controller. The simulation results show that LQR based control approach provides better results than PID based control approach in terms of settling time and rise time. Both control methods do not produce any overshoot.

Ethical Statement

The authors have no conflicts of interest to declare.

Ethics Committee Approval

Our study, whose information is given above, does not require any ethics committee approval. The authors acknowledge and declare that no breach of ethical rules has been made during the preparation and publication of the study.

Author Contributions

Research Design (CRediT 1) E.H.Ç. (%40) - H.H.B. (%30) - T.Ü. (%30)

Data Collection (CRediT 2) E.H.Ç. (%40) - H.H.B. (%30) - T.Ü. (%30)

Research - Data Analysis - Validation (CRediT 3-4-6-11) E.H.Ç. (%40) - H.H.B. (%30) - T.Ü. (%30)

Writing the Article (CRediT 12-13) E.H.Ç. (%40) - H.H.B. (%30) - T.Ü. (%30)

Revision and Improvement of the Text (CRediT 14) E.H.Ç. (%40) - H.H.B. (%30) - T.Ü. (%30)

Financing

This research received no specific grant from any funding agency in the public, commercial, or not-for-profit sectors.

REFERENCES

- [1] R. Mar, A. Goyal, V. Nguyen, T. Yang, W. Singhose, Combined input shaping and feedback control for double pendulum systems, *Mechanical Systems and Signal Processing*. 85 (2017), 267–277. doi: 10.1016/j.ymssp.2016.08.012
- [2] X. Xie, J. Huang, Z. Liang, Vibration reduction for flexible systems by command smoothing, *Mechanical Systems and Signal Processing*. 39(1-2) (2013), 461-470. doi: 10.1016/j.ymssp.2013.02.021
- [3] D. Fujioka, W. Singhose, Input-Shaped Model Reference Control of a Nonlinear Time-Varying Double-Pendulum Crane, içinde: *10th Asian Control Conference (ASCC)*, Kota Kinabalu, Malaysia, 2015, 1–6. doi: 10.1109/ASCC.2015.7244565
- [4] S. Garrido, M. Abderrahim, A. Gimenez, R. Diez, C. Balaguer, Anti-Swinging input shaping control of an automatic construction crane, *IEEE Transactions on Automation Science and Engineering*. 5 (3) (2008), 549–557. doi:10.1109/TASE.2007.909631
- [5] H.I. Jaafar, Z. Mohamed, M.A. Shamsudin, N.A. Mohd Subha, L. Ramli, A.M. Abdullahi, Model reference command shaping for vibration control of multimode flexible systems with application to a double-pendulum overhead crane, *Mechanical Systems and Signal Processing*. 115 (2019), 677–695. doi: 10.1016/j.ymssp.2018.06.005
- [6] H.I. Jaafar, N.M. Ali, Z. Mohamed, N.A. Selamat, A.F.Z. Abidin, J.J. Jamian, A.M. Kassim, Optimal Performance of a Nonlinear Gantry Crane System Via Priority-Based Fitness Scheme in Binary PSO Algorithm, içinde: Volume 53: *5th International Conference on Mechatronics (ICOM'13)*, 2013, Kuala Lumpur, Malaysia, 012011. doi:10.1088/1757-899X/53/1/012011.
- [7] M.J. Maghsoudi, Z. Mohamed, A.R. Husain, M.O. Tokhi, An optimal performance control scheme for a 3D crane, *Mechanical Systems and Signal Processing*. 66-67 (2016), 756–768. doi: 10.1016/j.ymssp.2015.05.020
- [8] M.I. Solihin, Wahyudi, M.A.S. Kamal, A. Legowo, Objective Function Selection Of GA-Based PID Control Optimization for Automatic Gantry Crane, içinde: *2008 International Conference on Computer and Communication Engineering*, Kuala Lumpur, Malaysia, 2008, 883–887. doi: 10.1109/ICCCE.2008.4580732
- [9] A. Alhassan, K.A. Danapalasingam, M. Shehu, A.M. Abdullahi, A. Shehu, Closed-loop schemes for position and sway control of a gantry crane system, *International Journal of Simulation: Systems, Science and Technology*. 17 (2016), 1-8. doi: 10.5013/IJSSST.a.17.32.28
- [10] A.O. Faouri, P. Kasap, Maximum likelihood estimation for the Nakagami distribution using particle swarm optimization algorithm with applications, *Necmettin Erbakan Üniversitesi Fen ve Mühendislik Bilimleri Dergisi*. 5(2) (2023), 169-178. doi: 10.47112/neufmbd.2023.19
- [11] A. Ünlü, İ. İlhan, A novel hybrid gray wolf optimization algorithm with harmony search to solve multi-level image thresholding problem, *Necmettin Erbakan Üniversitesi Fen ve Mühendislik Bilimleri Dergisi*. 5(2) (2023), 190-204. doi: 10.47112/neufmbd.2023.21
- [12] S. Bandong, M. R. Miransyahputra, Y. Setiaji, Y. Y. Nazaruddin, P. I. Siregar and E. Joelianto, Optimization of Gantry Crane PID Controller Based on PSO, SFS, and FPA, içinde: *2021 60th Annual Conference of the Society of Instrument and Control Engineers of Japan (SICE)*, Tokyo, Japan, 2021, 338-343.
- [13] H.I. Jaafar, Z. Mohamed, PSO-Tuned PID Controller for A Nonlinear Double-Pendulum Crane System, içinde: Volume 752: M. Mohamed Ali, H. Wahid, N. Mohd Subha, S. Sahlan, M. Md. Yunus, A. Wahap, (Ed.) *AsiaSim 2017 Modeling, Design and Simulation of Systems*, Springer, Singapore, 2017: s. 203–215. doi: 10.1007/978-981-10-6502-6_18
- [14] M. I. Solihin, Wahyudi, M. A. S. Kamal and A. Legowo, Objective Function Selection of GA-Based PID Control Optimization for Automatic Gantry Crane, içinde: *2008 International Conference on Computer and Communication Engineering*, Kuala Lumpur, Malaysia, 2008, 883-

887. doi: 10.1109/ICCCE.2008.4580732
- [15] Ü. Önen, A. Çakan, Anti-Swing control of an overhead crane by using genetic algorithm based LQR, *International Journal of Engineering and Computer Science*. 6(6) (2017), 21612-21616. doi: 10.18535/ijecs/v6i6.12
- [16] K.T. Mohamed, M.H. Abdel-razak, E.H. Haraz, A.A. Ata, Fine tuning of a PID controller with inlet derivative filter using pareto solution for gantry crane systems, *Alexandria Engineering Journal*. 61(9) (2022), 6659-6673. doi: 10.1016/j.aej.2021.12.017
- [17] H. W. Comma, Adaptive PID Control Design Based on Generalized Predictive Control (GPC), içinde: Volume 2: Proceedings of the 2004 IEEE International Conference on Control Applications, Taipei, Taiwan, 2004: s. 1685-1690. doi: 10.1109/CCA.2004.1387619
- [18] B. Yang, Z.X. Liu, H.K. Liu, Y. Li, S. Lin, A GPC-based multi-variable PID control algorithm and its application in anti-swing control and accurate positioning control for bridge cranes, *International Journal of Control, Automation and Systems*. 18 (2020), 2522–2533. doi: 10.1007/s12555-019-0400-2
- [19] M.I. Solihin, Wahyudi, A. Legowo, Fuzzy-Tuned PID anti-swing control of automatic gantry crane, *Journal of Vibration and Control*. 16(1) (2010), 127–145. doi:10.1177/1077546309103421
- [20] H. Shi, G. Li, X. Ma, J. Sun, Research on nonlinear coupling anti-swing control method of double pendulum gantry crane based on improved energy, *Symmetry*. 11(12) (2019), 1511. doi:10.3390/sym11121511
- [21] R. Ramirez-Juarez, M. Ramirez-Neria, A. Luviano-Juárez, Tracking Trajectory Control of a Double Pendulum Gantry Crane Using ADRC Approach, içinde: H.A. Moreno, I.G. Carrera, R.A. Ramirez-Mendoza, J. Baca, I.A. Banfield (Eds.), *Advances in Automation and Robotics Research. LACAR 2021. Lecture Notes in Networks and Systems*, Springer, Cham, 2022: s. 92–100. doi:10.1007/978-3-030-90033-5_11
- [22] D. Gutiérrez-Oribio, Á. Mercado-Urbe, J.A. Moreno, L. Fridman, Joint swing-up and stabilization of the reaction wheel pendulum using discontinuous integral algorithm, *Nonlinear Analysis: Hybrid Systems*. 41 (2021), 101042. doi:10.1016/j.nahs.2021.101042
- [23] Y. Zhao, X. Wu, F. Li, Y. Zhang, Positioning and swing elimination control of the overhead crane system with double-pendulum dynamics, *Journal of Vibration Engineering & Technologies*. 12 (2024), 971–978. doi:10.1007/s42417-023-00887-8
- [24] M. Zhang, X. Ma, X. Rong, X. Tian, Y. Li, Adaptive tracking control for double-pendulum overhead cranes subject to tracking error limitation, parametric uncertainties and external disturbances, *Mechanical Systems and Signal Processing*. 76–77 (2016), 15–32. doi:10.1016/J.YMSSP.2016.02.013
- [25] D. Karaboga, An Idea Based On Honey Bee Swarm For Numerical Optimization, Technical Report-tr06, Computer Engineering Department, Engineering Faculty Erciyes University, 2005.
- [26] H.H. Bilgic, M.A. Sen, M. Kalyoncu, Tuning of LQR controller for an experimental inverted pendulum system based on the bees algorithm, *Journal of Vibroengineering*. 18(6) (2016), 3684-3694. doi: 10.21595/jve.2016.16787
- [27] K. Vanchinathan, N. Selvaganesan, Adaptive fractional order PID controller tuning for brushless dc motor using artificial bee colony algorithm. *Results in Control and Optimization*. 4 (2021), 100032. doi: 10.1016/j.rico.2021.100032
- [28] D. L. Zhang, Y.-G. Tang, X.-P. Guan, Optimum design of fractional order PID controller for an AVR system using an improved artificial bee colony algorithm, *Acta Automatica Sinica*. 40(5) (2014), 973-979. doi: 10.1016/S1874-1029(14)60010-0
- [29] Z.-L. Gaing, A particle swarm optimization approach for optimum design of PID controller in AVR system, *IEEE Transactions on Energy Conversion*. 19 (2) (2004), 384-391. doi: 10.1109/TEC.2003.821821.