

Finite element stress analysis and topological optimization of a commercial aircraft seat structure

Christian Dalo Amaze¹, Sireetorn Kuharat^{1*}, O. Anwar Bég¹, Ali Kadir¹, Walid Jouri¹, Tasveer A. Bég²

¹MPESE, Corrosion Lab, 3-08, Mechanical Engineering Dept., Salford University, Manchester, M54WT, United Kingdom

²Engineering Mechanics Research, Israfil House, Dickenson Rd., Manchester, United Kingdom

Orcid: C.D. Amaze (0009-0005-2696-4195), S. Kuharat (0009-0000-5739-9137), O.A. Beg (0000-0001-5925-6711), A. Kadir (0000-0001-5122-8345)

Abstract: In recent years, the Finite Element Method (FEM) has emerged as a cornerstone in the field of seating design, particularly within the aircraft industry. Over the past decade, significant advancements in Finite Element (FE) analysis techniques have revolutionized the seat industry, enabling the creation of safer and more cost-effective seat designs. The accuracy of FE analysis plays a pivotal role in this transformation. In the process of constructing a reliable finite element model, the selection and precise manipulation of key parameters are paramount. These crucial parameters encompass element size, time scale, analysis type, and material model. Properly defining and implementing these parameters ensures that the FE model produces accurate results, closely mirroring real-world performance. Verification of Finite Element Analysis (FEA) results is commonly accomplished through experimental methods. Notably, when the parameters are appropriately integrated into the modelling process, FE analysis outcomes closely align with experimental results. This study aims to leverage the power of FEM in performing static stress analysis and topology optimization of aircraft seats using the SOLIDWORKS commercial finite element platform. By simulating loading conditions, this research calculates static stresses and displacements experienced by the aircraft seat. For AL7075-T6(SN) the structural analysis demonstrates that this material had a maximum stress of 125.2 N/mm² and a minimum stress of 0.0039 N/mm². Due to its strong 4.034 factor of safety, the component may have been over-engineered for its intended use. However, at 2.32 kg, the component's mass and \$2.304/kg material cost showed a high design cost. The maximum Y-component of displacement was 0.0606 mm, which was acceptable but could have been optimized to decrease material use and expense without affecting structural integrity. After performing topology optimization on Simulation 1 of AL7075-T6(SN), several improvements have been achieved. The maximum stress sustained by the component has been elevated to 189.4 N/mm². However, it is worth noting that the minimum stress has also risen, although to a negligible value of 0.0006 N/mm². The compromise in this scenario is characterized by a fall in the factor of safety to 2.666, suggesting a design that is more optimal but possibly associated with more risk. The most notable improvements, however, concern weight reduction. The overall mass of the component saw a substantial reduction, reaching 1.89 kg, which represents a notable improvement on the original design. Through a comprehensive topology optimization study, the weight of the airplane seat is remarkably reduced by up to 30%, while still prioritizing passenger safety. The success of this optimization showcases the potential for substantial weight savings in aircraft seat design without compromising safety standards.

Keywords: Finite Element Method (FEM), Aircraft Seat Industry, FE Analysis, Static Stress Analysis, Topology Optimization, Experimental Validation, Material Model, Safety Standards, Weight Reduction, Seating Design.

1. Introduction

The aircraft seat refers to the seating area where passengers sit during their flight journey. These aircraft seats are typically arranged in rows along seat tracks inside the plane. When it comes to aircraft seats, they come with

various fundamental characteristics for comfort, functionality and carefully designed features [1]. Since the 1930s when the first passenger airplane was introduced, aircraft manufacturers have been making continuous efforts to ensure the safety of passengers and crew during

*Corresponding author:

Email: S.Kuharat2@salford.ac.uk

Cite this article as:

Amaze, C., Kuharat, S., Bég, O., Kadir, A., Jouri, W., Bég, T. (2024). Finite element stress analysis and topological optimization of a commercial aircraft seat structure. *European Mechanical Science*, 8(2): 54-70. <https://doi.org/10.26701/ems.1441584>

History dates:

Received: 28.02.2024, Revision Request: 11.03.2024, Last Revision Received: 12.03.2024, Accepted: 15.03.2024



© Author(s) 2024. This work is distributed under <https://creativecommons.org/licenses/by/4.0/>



their flights. Safety-related aircraft seat requirements should be considered in 3 major cases: take-off, cruise, and landing. Thus, international flight authorities such as the Federal Aviation Administration (FAA), European Aviation Safety Agency (EASA) and Joint Aviation Authorities (JAA) have implemented strict rules during these three cases [2].

The weight of the aircraft seat also contributes to the total weight of the aircraft, hence why it is recommended to use lightweight materials during the design and manufacturing process. Since the aircraft seat is the focus of comfort for the passengers, it is essential to design a lightweight seat without creating additional load on the aircraft while simultaneously retaining the strength of the seat [3]. The vast majority of aircraft seat manufacturers use aluminium as the main component, although in recent times, carbon composite structures and plastics have been introduced for the sole purpose of reducing weight while maintaining strength. Other manufacturers combine all three materials to produce different types of seat structures. One example of a manufacturer that uses the latter is Avio Interiors [4]. This Italian company claims that the combination of carbon fibre composites and aluminium produces stronger seats rather than using both materials individually. The seats of an aircraft can be designed in various shapes, sizes, and comfort levels depending on the type of aircraft. Commercial aircraft have mainly four classes of seats namely, first-class seats, business-class seats, premium seats, and economy seats. These classes of aircraft seats have various features that vary depending on the ticket price. The 4 main types of commercial aircraft seat are shown Figure 1.

This article focuses on the *computational stress analysis and topological optimization of the support structure of an aircraft seat*. As such this study aims to achieve a better-optimized structure for the base frame assembly of an aircraft seat.

When designing an aircraft seat, the comfort of the pas-

senger must be taken as a priority. In that sense, factors such as the number of seats, space limitations, and location of each seat must be considered. Generally, the most used material for a passenger seat base frame is aluminium. This aluminum material is assembled to form a seat base, seat back, center armrest, and cushion space.

The primary structure for aircraft passenger seats typically consists of two stretcher tubes or rails that span the front and rear of the seat [5]. These stretcher tubes support spreader members, which run along opposite sides of the seat and provide support for the seat cushions and seat backs. Additionally, leg assemblies are positioned at intervals along the length of the stretcher tubes and are connected to tracks mounted on the floor to provide further support for the seats. Depending on the number of seats and the layout, the stretcher tubes' spreaders and legs will be spaced at varying intervals along the length of the tubes. Depending on the layout of the aircraft, the number of seats in a row, and the placement of the row in the aircraft, the legroom at the end of the row may be different from that at the beginning of the row. Whether the seat faces forward or backwards, where the legs are attached to the stretcher tubes, and where the spreaders are attached to the stretcher tubes all affect the quality of the connection between the spreaders and the stretcher tubes, as well as the leg assemblies [6].

To ensure safety, it is imperative to fulfil the essential structural prerequisites, while simultaneously enabling the airline operator to both efficiently and economically maintain the seating arrangements. Frequently, there arises a need to modify the arrangement of seats within an aircraft to accommodate various passenger requirements and adapt to market demands. Historically, the process of assembling and disassembling seats has been intricate, laborious, and costly [7]. Frequently, it necessitated the disassembly of a significant portion of the seat support structure to facilitate the movement or alteration of the seating arrangement. Additionally, any decrease in seat weight that does not compromise the structural va-



Figure 1. Top left- economy class, top right- premium economy class, below left- business class, below right- first class.

lidity of the seats results in fuel savings for the airline's aircraft and a reduction in maintenance costs.

The objective of this study is to introduce an enhanced structure for supporting aircraft seats, wherein the base frame structure can be efficiently and effortlessly attached or detached from the remaining support structure, without compromising the seat's structural integrity. Another objective of the study is to offer an enhanced structure for supporting aircraft seats while minimizing the number of components involved. Finally, this study aims to offer an aircraft seat support structure that can fulfil the standard safety requirements while also being lightweight. In summary, the standard configuration of an airplane seat base frame consists of a front leg structure designed to support a front horizontal stretcher component and a rear leg structure intended to support a rear horizontal stretcher component. The aircraft seat industry plays a pivotal role in ensuring passenger comfort, safety, and satisfaction during air travel. Over the past decade, the use of Finite Element Method (FEM) in the design and analysis of aircraft seats has seen significant growth, revolutionizing the industry's approach to seat development. A detailed literature review explores the critical aspects of FEM utilization in the aircraft seat industry, emphasizing its impact on design efficiency, safety, and weight optimization. The standard class passenger seat used in this research was modelled with the help of SolidWorks software, a computer-aided drawing tool which utilizes the FEM to conduct static analysis on the computer-aided design (CAD) model under various loading and boundary conditions.

2. Finite Element Method Approach

The fundamental principle underlying the FEM involves the process of simplifying a complex problem to facilitate its solution [8]. This technique involves discretizing the domain under investigation into a series of smaller, easier-to-manage components using finite elements and subsequently reconnecting these elements at specific locations referred to as nodes. The FEM is an effective tool for predicting displacements, stresses, and strains in a structure subjected to a given set of loads and is thus widely used in structural analysis. This is exactly the topic that we want to investigate more in this report [9]. To facilitate the essential simulations of finite element analysis, it is imperative to generate a mesh comprising numerous minute elements that collectively define the structural configuration. Each component requires its own set of calculations, the sum of which gives the overall result for the entire structure. There are three distinct phases to the finite element analysis procedure: preprocess, process, and post-process. During the preprocessing, it is paramount to select the type of analysis. For this study, static-structural, topological, and frequency analyses are performed in SOLIDWORKS. The initial phase in the problem-solving process entails the discernment and delineation of the problem at hand. Therefore, before commencing the analysis of a structure, we must inquire about the following questions: What are the pri-

mary physical phenomena that exert a significant influence on structural integrity? Does the problem exhibit characteristics of static or dynamic behavior. Do motions or material properties exhibit linearity or non-linearity? What are the specific key results that have been requested? What is the desired level of precision being pursued? The responses to these inquiries are of utmost importance in the process of determining an appropriate structural model.

To conduct a static analysis, the CAD geometry is first subjected to the geometry cleaning, meshing, modelling, and solution processes of the FEA software, afterwards, static load values are applied to the model, and finally, boundary conditions are set [10]. In this analysis, the primary concept of significance revolves around the assumption that temporal factors such as time hold negligible importance and can be disregarded in their impact on the outcomes. In this analysis, the finite element software, SolidWorks effectively converges towards the solution, aligning with the specified boundary conditions and the constructed model. Ultimately, the program provides the user with stress, strain and displacement values, accompanied by visually appealing geometric graphics. Static analysis can be performed using both linear and non-linear methods. In linear static analysis, there are two main assumptions:

- The behavior of the structure is characterized by linearity, meaning it adheres to Hooke's Law.
- The loading is static.

In SOLIDWORKS the FEM used is derived around the Principal of Minimum Energy. Initially, the domains must be divided into many sub domains / subregions which are denoted using the parameter N. Each subdomain is known as an element; It can be stated that the total potential energy in the system is the sum of the potential energy of each of the subdomains as shown below:

$$\pi = \sum_{i=1}^N \pi_i \quad (1)$$

Where " π " is the potential energy and "1" is the element number. The energy at each of the subdomains can be calculated using the following equation:

$$\pi = \int_{V_1} \left[\varepsilon^T C \left(\frac{1}{2} \varepsilon - \bar{A} \Delta T \right) - f^T u \right] dV - \int_{S_{\sigma_i}} t^T u dS \quad (2)$$

In the equation above the volume V is related to the volume of the specific element, the term S_{σ_i} relates to the section of the surface which bounds the element. In order to determine the potential energy in the element, the elastic constant matrix C, the displacement matrix u, the strain matrix ε are used. The displacement matrix can be defined using the displacements and displacement derivatives "q" and interpolation functions "D_i". The combination of these function will define the changes in position of the elements within the system. This can be represented in the equation below:

$$u_i = D_i \times q_i \quad (3)$$

On the other hand, the strain matrix can be created using the displacements and displacement derivatives previously stated and the matrix of strain with respect to the position within the element “ B_i ”. The sum of these components produces the strain matrix as shown below:

$$\varepsilon = B_i \times q_i \quad (4)$$

Using the equations presented above and re-arrangement of the potential energy equation, the equivalent forces applied to each node can be calculated as follows:

$$F_i = \int_{V_i} D_i^T f \, dV + \int_{S_{\sigma_i}} D_i^T t_n \, dS + \int_{V_i} B_i^T C_i \bar{A}_i \Delta T_i \, dV \quad (5)$$

The stress matrix can be determined when the following manipulations, conditions and parameters are applied:

- The total potential energy equation must be manipulated to include the Stiffness matrix for the entire region “ K ”; the stiffness matrix for all nodal derivatives, “ q ” and the assembled nodal load matrix “ F ”.
- The potential energy must now be minimalised when considering the unknown nodal displacements.
- The nodal displacements conditions on the surface of the elements are satisfied.

Once completed the stress at each of the elements can be approximated using the elastic constant matrix “ C_i ”; the matrix of strain and the matrix of nodal variables “ q_i ”. It is worth noting that all functions stated are with respect to the individual elements and will be applied to all elements in the system. The following equation can be produced:

$$\sigma_i = C_i \times B_i \times q_i \quad (6)$$

However, the equations presented above are only approximations for the true solutions, Increasing the accuracy of the results is a mandatory process in FEA in order to obtain values which closely represent the true solutions. The following Steps can be taken to improve the results produced:

- a) The accuracy of the results can be increased by decreasing the size of the elements while increasing the number of elements in the system. This will be the main method used to improve accuracy since the h-adaptive method utilises this process between iterations throughout critical locations.
- b) The second method of increasing accuracy is by utilising higher order interpolation methods. This can greatly increase the accuracy of the results at the cost of higher time of investigation. However, this method cannot be used with multi-part assemblies since the meshes are not continuous.

- c) The last method is by using the combination of the two methods stated above, this is not feasible for this project since there is more than one component in the simulation meaning only the h-adaptive method can be used.

The deformation computed in SOLIDWORKS is influenced by a number of factors, including the material characteristics. Linear elastic behavior, in which strain is inversely proportionate to applied stress, is the simplest connection between stress and strain. The relationship between these two changes depending on the material and is known as Young’s modulus, E . In the situation that a system lacks a linear correlation between the forces exerted and the deformations experienced, it is referred to as a non-linear system. In this study, a non-linear analysis will be conducted. The purpose of this analysis is to evaluate the SOLIDWORKS model characteristics and its ability to withstand loading under specific boundary conditions.

3. Material Selection

The selection of materials is a critical step in the aircraft seat design process. The selection of materials for the system to be designed will have a significant impact on its strength, cost, weight, and other key characteristics. To select the appropriate material, it is imperative to have a comprehensive understanding of the system’s requirements that need to be met. The consideration of material characteristics is of utmost significance and serves as the first assumption when representing any material model in Finite Element Analysis (FEA). Incorrect entry of material information might have a significant impact on the outcomes [11]. If erroneous data is provided as input in the FEA process, the resulting output will always be erroneous as well. It is important to consistently exercise caution and attentiveness while inputting material information into the FEA system. The process of defining material in FEA is comparatively less intricate than accurately reflecting real-world materials. Different materials possess a range of material parameters, including yield stress, ultimate stress, Young’s modulus, Poisson’s ratio, bulk modulus, thermal conductivity, elongation, specific heat, stress-strain curve, and electric properties, among others. In the field of FEA, it is not necessary to explicitly provide all material properties to represent the material. The specific material details that need to be considered depend on the kind of FE analysis being conducted, such as linear or nonlinear solutions, static or dynamic analysis, steady state, or time-dependent analysis.

The necessary qualities of a material that are needed for basic finite element analysis types are shown in Table 1.

When defining the properties of a material, it is essential to specify two specific properties in addition to thermal properties. The key structural analysis parameters are Young’s modulus and Poisson ratio. The majority of materials exhibit Poisson ratio values within the range of 0.0 to 0.5. Incompressible substances, such as rubber,

Table 1. Types of finite element analysis

Material Properties	Linear Static	Non-Linear Contact	Non-Linear Material	Non-Linear Dynamic	Fatigue	Linear Dynamic	Thermal	Thermal Structural	Transient structural
Young's Modulus	Yes	Yes	Yes	Yes	Yes	Yes		Yes	Yes
Poisson Ratio	Yes	Yes	Yes	Yes	Yes	Yes		Yes	Yes
Mass Density	Yes	Yes	Yes	Yes	Yes	Yes		Yes	Yes
Thermal Conductivity							Yes		
Thermal expansion								Yes	
Specific heat									Yes
Stress-Strain curve			Yes						
Fatigue Life curve					Yes				

have a ratio of around 0.5. In this article, the materials AL6061-T6(SS), AL7075-T6(SN), 1023Carbon steel sheet (SS), and KYDEX®T will all be simulated, compared, and used in a certain aspect of either the design of the and/or the assembly of the aircraft seat frame. KYDEX®T, a thermoplastic acrylic-polyvinyl chloride material manufactured by SEKISUI KYDEX, will also be included in the analysis. High-strength aluminium alloys offer lightweight possibilities for aircraft designers due to their low density. Considering this rationale, it is a commonly employed material in the aviation sector. Furthermore, it has been predicted that aluminium satisfies the necessary strength criteria in the context of material investigations.

4. Boundary and Loading Conditions

4.1. Boundary conditions

These refer to the external forces that must be considered to effectively analyse a model or determine the resulting deformations caused by these forces. Boundary conditions are a set of predetermined values that are known and established during the process of constructing a model from scratch [12]. The way the seating design is constrained exerts a substantial influence on the outcomes and necessitates careful consideration. Models that are either over-constrained or under-constrained can result in highly inaccurate stress figures, rendering them essentially useless for the stress engineer. Boundary conditions are essential constraints that must be satisfied to obtain a solution for a boundary value problem. A boundary value problem refers to a mathematical problem involving a system of differential equations that needs to be solved within a specific domain [13]. The known conditions for this problem are provided on the boundary of the domain. In the process of developing a finite element model, it is imperative to commence with the establishment of the mesh model. Subsequently, the contacts are defined, ensuring accuracy and precision. Finally, the appropriate boundary conditions are inserted, guaranteeing the integrity and reliability of the model. To ensure the elimination of rigid-body motion and the accurate representation of physical conditions, the finite element model must be appropriately restrained through

the implementation of displacement constraints. In this study, the airplane seat under consideration is *connected to other components using bolts and pins* [14]. It is not advisable to consistently impose constraints upon the nodes situated on the inner surface of the holes where pins or bolts are positioned, as they lack physical constraint. When relocation limits are put around a hole (discontinuity), they often cause an unexpected build-up of stress. This study also incorporates boundary conditions, including both limitations and contacts. In the context of static finite element analysis for an aircraft seat, it is standard to consider the base of the seat as constant i.e., designating it as a fixed support inside the study. The modelling of solid structures often involves the use of a displacement-based model. Boundary conditions often include the imposition of certain displacement values at

Tables 1. a, b, c: Mechanical properties for aircraft seat simulations conducted

Mechanical Properties	Value
Tensile Strength	570MPa
Yield Strength	505MPa
Modulus of Elasticity	72000MPa
Poissons Ratio	0.33

1a). Mechanical Properties of AL6061-T6(SS), 1b) Mechanical Properties of AL7075-T6(SN)

Mechanical Properties	Value
Tensile Strength	310MPa
Yield Strength	275MPa
Modulus of Elasticity	69000MPa
Poissons Ratio	0.33

1c). Mechanical Properties of KYDEX®T

Mechanical Properties	Metric
Tensile Strength	42MPa
Yield Strength	40MPa
Modulus of Elasticity	2600MPa
Poissons Ratio	0.433

designated locations on the structure. The airplane seat is comprised of several components, necessitating the need to establish connections between them. In this article, SolidWorks is used as the pre-and post-processing tool for generating the mesh of the model, computing the stress distributions, and visualizing the outcomes of the finite element analysis.

4.2. Loading Conditions

In the context of an analysis model, the loads refer to the mechanical forces and thermal loading that exert their influence upon the object or component. The primary loading conditions used in FEA are force, pressure, and temperature. These may be applied to many geometric components such as points, surfaces, edges, nodes, and elements, or can be applied remotely from a specific feature [15]. The application of loads and constraints is specified after the selection of the analysis type, setting of fundamental parameters such as materials, and completion of the meshing process for the component. To comprehensively understand probable failure modes, it is essential to establish them based on the maximum predicted loads that the product may encounter during its lifespan, as opposed to the regular loads. To obtain precise and reliable outcomes, it is imperative to verify that the loads being imposed are strategically distributed across the appropriate surfaces or specific sections. The proper application of loads is a critical component of this simulation. The surface or section of a surface on which a force is applied must be carefully considered as it can significantly impact the results. In this analysis, due to the lack of knowledge regarding deformations, the parameters that are entered are limited to the average weight values of passengers occupying an aircraft seat. The loads under consideration are classified as distributed loads within the model. In the context of stress engineering, it is imperative to assume that the weight of a passenger is uniformly distributed on the seat. In the present scenario, the weight of a passenger is considered to be 1000N. However, a total weight of 1500N will be entered to make up for some missing parts, such as the seat cushion, backrest, and seat belt.

5. Topology Optimization

Topology optimization (TO) is a computational technique used for optimizing the arrangement of materials within a specified area, based on a set of predefined loads, conditions, and constraints. It employs algorithmic models to achieve the desired shape optimization. The use of this method enables the attainment of the most optimal geometric structure for the intended model, considering the prescribed boundary conditions and the designated objective function. The use of topology optimization enables the created models to achieve material reductions and maintain a minimal weight [16]. The first phase of its operation necessitates the involvement of an engineer who is responsible for generating a CAD model. During this step, the engineer carefully incorporates various loads and limits while considering the specific specifi-

cations of the project. Subsequently, the program eliminates unnecessary parts and produces a single optimized mesh-model idea that is ready for analysis by an engineer. Topology optimization relies on a pre-existing model that is built to operate effectively. Topology optimization is an initial step in the design process that involves identifying the minimum required design space for the subsequent optimization of the structure. Subsequently, the topology optimization software (SolidWorks) virtually generates pressure on the design from various angles, conducts structural integrity analysis, and identifies unnecessary material. It is an excellent tool for aircraft seat design.

6. Solidworks Finite Element Simulation-Walkthrough

6.1. Geometry Design

The process of assembling the airplane seat frame using SolidWorks entails the systematic integration of the many individual components to construct a seating framework that is both operational and secure. The procedure begins by generating an entirely new assembly in SolidWorks, whereby each constituent, such as the seat base, connecting rod, and leg spreaders, is intricately designed. By using the mating features offered by SolidWorks, the components are then joined, therefore guaranteeing precise alignment and optimal operational performance. The process of material selection and structural analysis is undertaken, followed by the generation of precise drawings for the manufacturing process. The separate and assembled components of the aircraft seat are shown in Figure 2 and 3.

6.2. Boundary Conditions

For the boundary conditions, we assume the base of the spreaders is constant, this means we define it as a fixed support in the analysis. The fixed-geometry fixture was selected and applied in the z-direction as shown in Fig. 4.

6.3. Loading Conditions

Since the deformations are unknown in this study, the average passenger weight for an aircraft seat is used as inputs

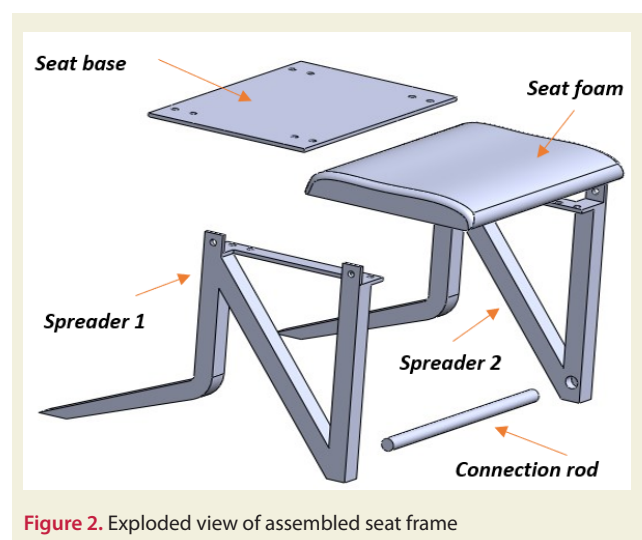

Figure 2. Exploded view of assembled seat frame

instead of random load values. The model considers these loads as the distributed load. This indicates that we assume a constant distribution of a passenger's weight across the seat. The analytical findings are accurate under this assumption. In this case, we will assume that the passenger weighs 1500N. Also, the seat foam was suppressed as it has a minimal effect on the total weight and will remain suppressed for the rest of the simulations (Fig. 5).

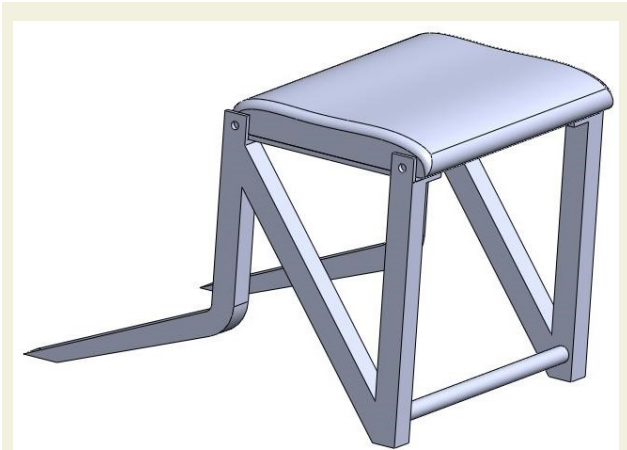

Figure 3. 3D Design of assembled seat frame.

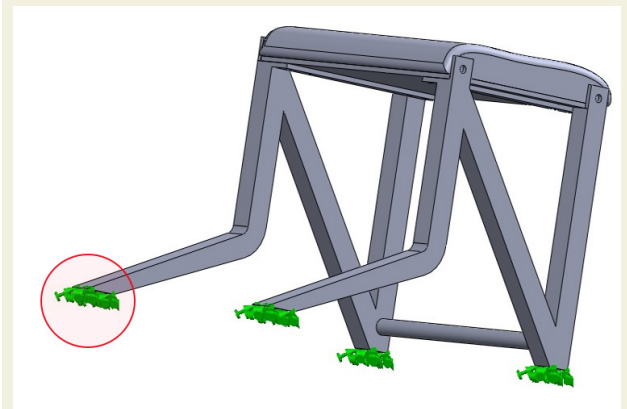

Figure 4. Application of boundary conditions

6.4. Mesh Design and Independence Study

6.4-1 Initial coarse mesh

For the initial simulation, an automatic mesh is designed initially to be coarse (Fig. 6) as shown below. The mesh dimension size is 37.44mm, however, the mesh is not at its finest. Therefore, the mesh size will be subsequently reduced until it accommodates the desired mesh independence criteria.

6.4-2 Jacobian Ratio

Jacobian ratio in SolidWorks often refers to a metric used to determine the mesh element quality inside a finite element analysis (FEA) simulation. The Jacobian ratio is used to evaluate the distortion or deformation of finite elements, such as tetrahedral or hexahedral elements, inside the finite element analysis (FEA) mesh. Obtaining precise simulation results necessitates the use of a high-quality mesh. In simple terms, the Jacobian ratio

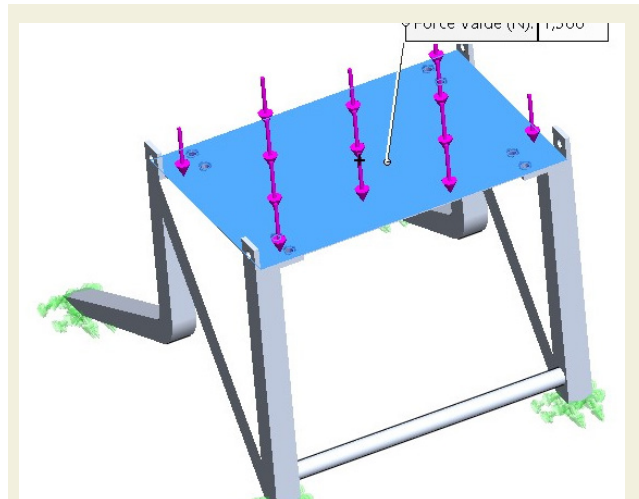

Figure 5. Application of Loading Conditions.

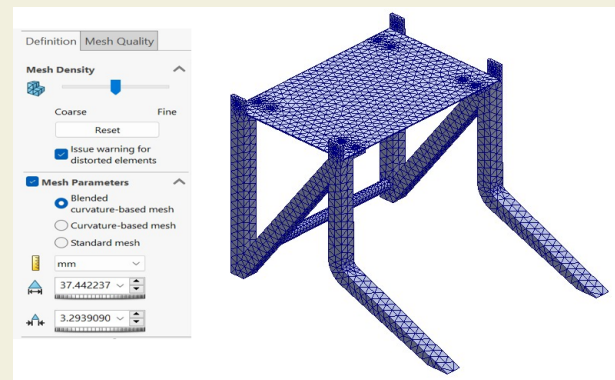

Figure 6. Simple initial mesh

measures the extent to which the form of an element deviates from an ideal shape. It is depicted in Fig. 7 for the current aircraft seat model.

6.4-3 Aspect Ratio

Aspect ratio is the measure of a geometry width to its height. It can also be used to describe any other form of visuals. It is critical to sustain a desirable and ergonomic aspect ratio so that the designs and models are accurate and fit together well. Fig 8 visualizes the different aspect ratios in the seat FEA model.

6.4-4 Connection modelling

A pin connection is selected to connect the seat base to the spreaders as shown in Fig. 9 below.

6.4-5 Mesh Independence Study

For the mesh Independence study, a graph between the mesh size and the maximum stress is plotted to determine the most appropriate mesh for the structure - three different meshes are studied- coarse, intermediate density and fine. However, before the maximum stress can be calculated, the material of the structure must be selected, therefore, for the mesh convergence graph, AL7075-T6(SN) is selected for all the parts of the structure. Fig. 10 shows the 3 different mesh designs used. In all cases

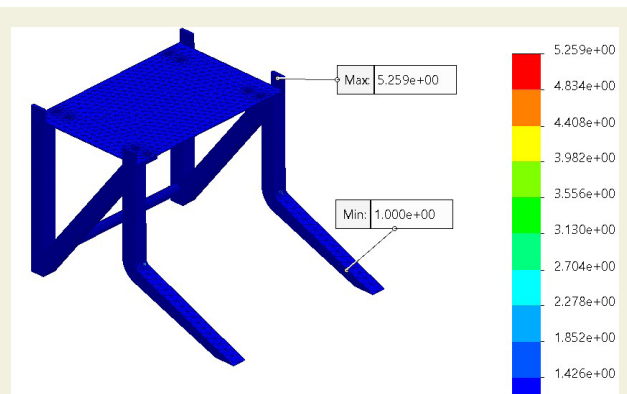

Figure 7. SOLIDWORKS Jacobian Ratio Plot.

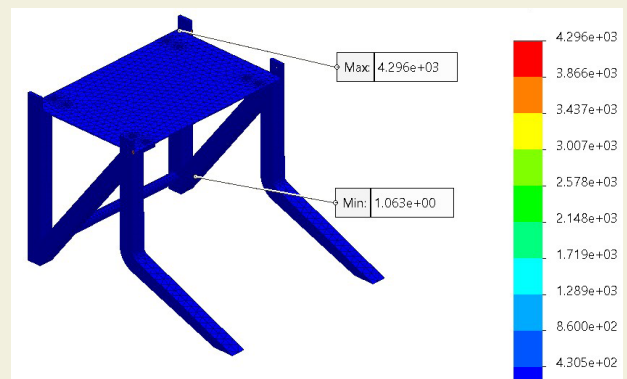

Figure 8. Aspect ratio plot.

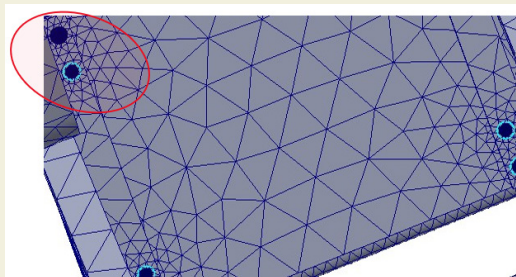

Figure 9. Connection pins prescribed in SOLIDWORKS.

tetrahedral 3-D elements are deployed. Fig. 11 shows the mesh independence plot. Table 2 shows the peak Von Mises stress computed for each of the three meshes designed.

Figures 10, 11 and Table 2 present the computational results for independence of mesh size and maximum stress in pounds per square inch (Psi). The research includes the use of 20, 15 and 10mm mesh sizes. It is evident that the maximum stress in the system is affected by the mesh size. The maximum stress rises gradually when the mesh size is reduced from 20mm to 10mm. This trend indicates that the smaller 10mm grid collects more information about the stress distribution in the system, leading to a more accurate stress calculation due to more interpolation points available in the fine mesh design.

7. Results

3 sets of SOLIDWORKS finite element simulations have been performed for the three different materials documented in Table 1- a) AL6061-T6(SS), b) AL7075-T6(SN) and c) KYDEX®T. All these materials are commonly employed in seat design in the aircraft industry. Additionally, a 4th simulation has been conducted combining these different materials for the different seat structural components.

7.1. Simulation 1 -AL6061-T6(SS)

7.1-1 Stress Analysis - Von-Mises Stress

A total force of 1500N is placed on the seat base as shown in the section, the materials are selected as shown in Table 1, a mesh size of 10mm is selected according to the mesh independence study and the study is run to calculate the maximum and minimum stress as shown in the figures below. Table 3 shows the specifications for the 2 spreaders, seat base and connection rod. The seat foam

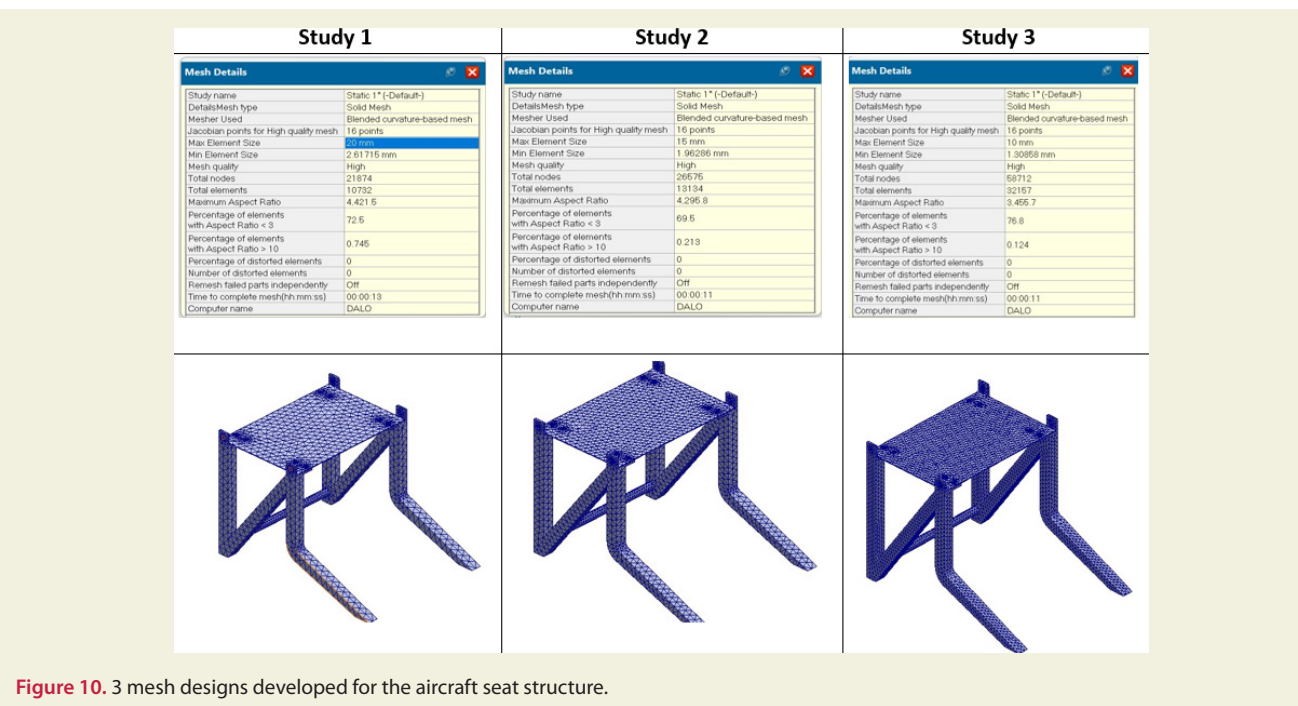

Figure 10. 3 mesh designs developed for the aircraft seat structure.

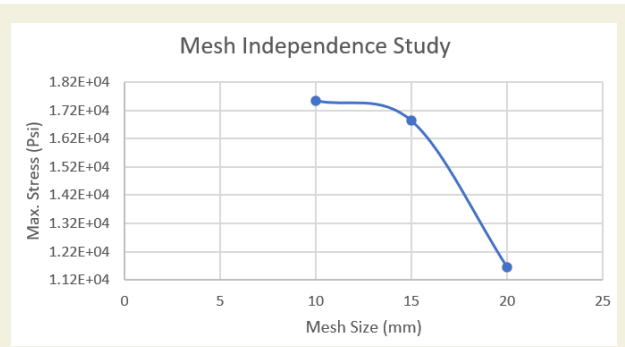

Figure 11. Mesh independence plot

Table 2. Peak stresses computed for 3 mesh design cases with AL7075-T6(SN) design material.

Mesh Study No.	Mesh Size (mm)	Max. Stress (Psi)
1	20	1.164e+04
2	15	1.683e+04
3	10	1.755e+04

is not simulated as it does not contribute to structural integrity and is related to comfort for passengers, not resilience of the seat design.

Table 3. Seat model component materials used in simulation 1.

Component	Material
Spreaders	AL6061-T6(SS)
Seat Base	AL6061-T6(SS)
Connection Rod	AL6061-T6(SS)

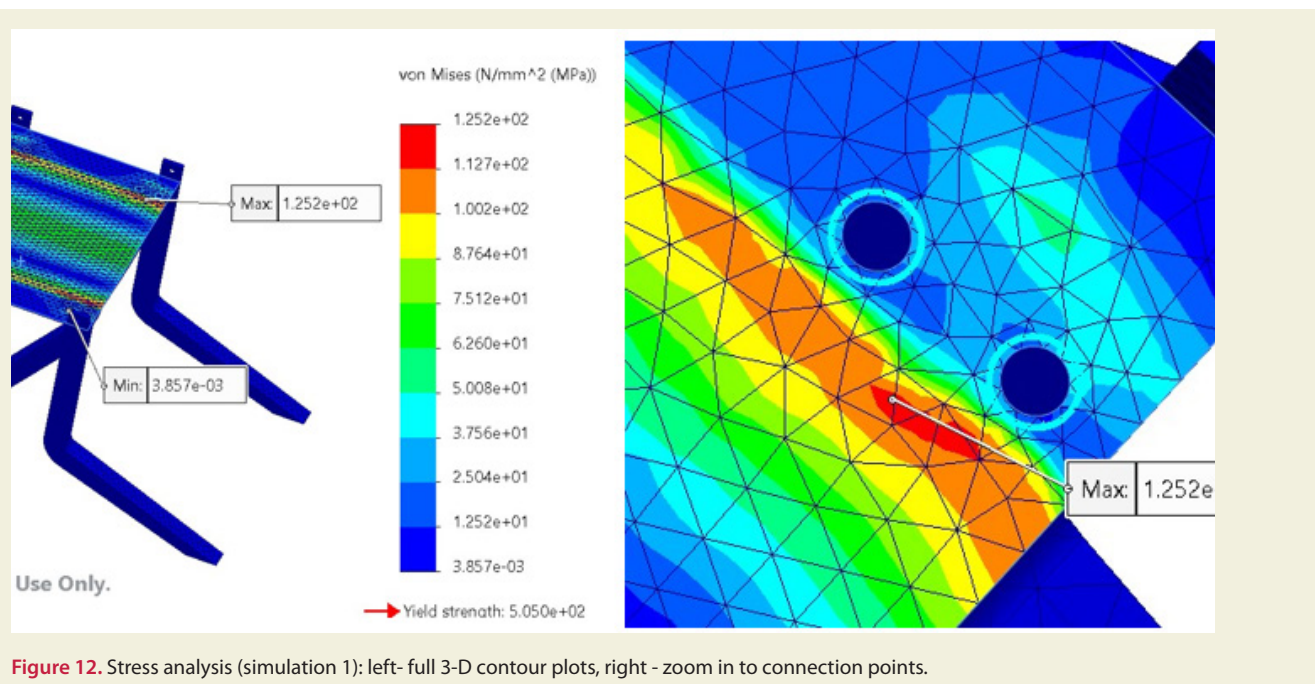

Figure 12. Stress analysis (simulation 1): left- full 3-D contour plots, right - zoom in to connection points.

The static nodal stress plot is given in Fig. 13.

7.1-2 Displacement Analysis (Y-Component of Displacement)

We focus on the Y-component of the displacement since it is the determining factor in the material's failure. Fig. 14 visualizes the displacement contour plot.

Fig. 15 shows the associated static displacement plot.

The displacement criteria must be satisfied for the maximum Y-Component displacement value to be smaller than 0.01 of the width of the Seat base. The following calculations are performed to check this:

$$\text{i.e., max. } y\text{-component of displacement} < \frac{1}{100} \text{ of (width of seat base)}$$

$$\text{width of seat base, } W = 383\text{mm}$$

$$\text{max. } y\text{-component of displacement of seat base} = 0.0606\text{mm}$$

$$\frac{1}{100} * 383 = 3.83\text{mm}$$

$$0.0606 < 3.83 \quad (7)$$

Therefore, the displacement criteria are met.

7.1-3 Factor of safety (Reserve Factor)

The factor of safety is a safety metric used in structural analysis inside the SolidWorks software. Structural efficiency is defined as the ratio between the maximum load that a structure can sustain and the load that is applied to it. The reserve factor may be determined by dividing the ultimate strength of a material by the applied load. The ultimate load refers to the maximum load capacity of a structure before its failure. The applied load refers to the

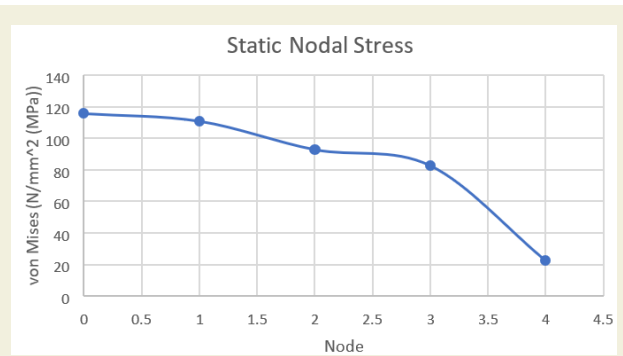

Figure 13. Static nodal stress (simulation 1)

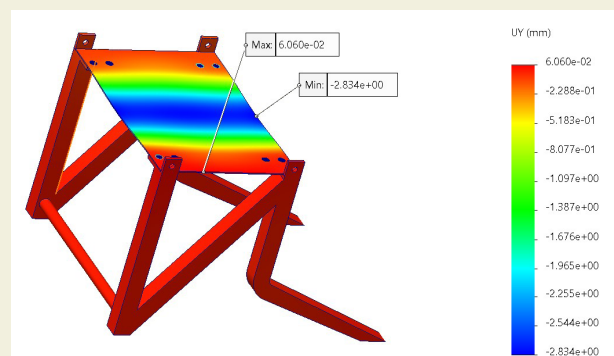

Figure 14. Y-Component of displacement (simulation 1).

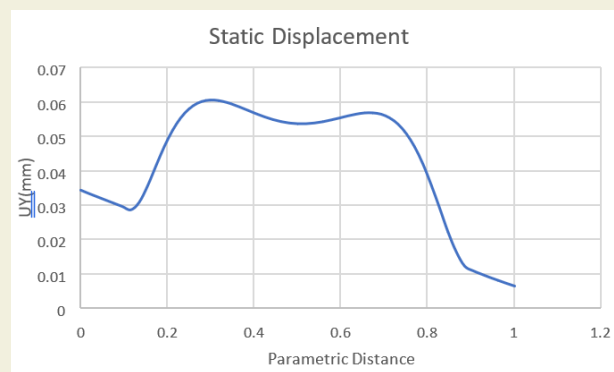

Figure 15. Static displacement plot (simulation 1).



Figure 16. Failure Criteria (factor of safety) computed In SOLIDWORKS for simulation 1

external force or weight that is exerted on the structure during the process of analysis. A Reserve Factor of 1.0 signifies that the structure has the *minimum capacity required to sustain the imposed load*, without any additional safety buffer. A Reserve Factor beyond 1.0 signifies that the structure has a certain degree of safety buffer, while a Reserve Factor below 1.0 suggests that the structure is prone to failure when subjected to the applied load. Fig. 16 shows the contour plot for factor of safety analysis in simulation 1.

Fig. 17 shows the factor of safety distribution plot for simulation 1.

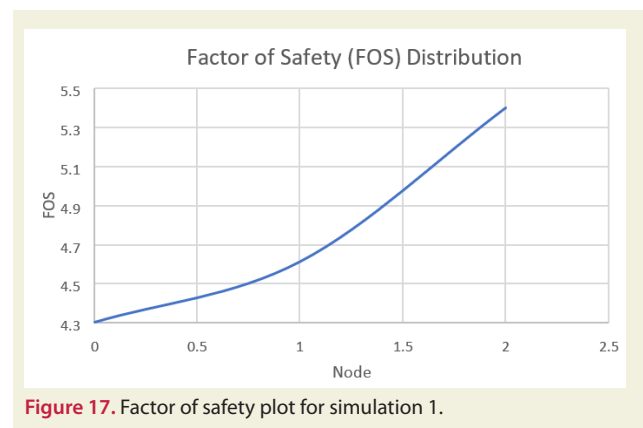

Figure 17. Factor of safety plot for simulation 1.

Table 4 summarizes the results extracted from the finite element analysis for Simulation 1 (AL7075-T6(SN)).

Table 4. Summary of simulation 1 - outputs with associated cost estimation

Properties	Values
Max. Stress	1.252e+02 N/mm ²
Min. Stress	3.857e-03 N/mm ²
Max Y-component of displacement	0.0606 mm
Factor of Safety	4.034
Total Mass	2.32kg
Price	\$2.304/kg

7.2. Simulation 2 - AL6061-T6(SS)

Table 5 shows the specifications for the 2 spreaders, seat base and connection rod for simulation 2. Again, the seat foam is not simulated.

7.2-1 Stress Analysis - Von-Mises Stress

The same procedure is executed as for simulation 1.

The static nodal stress plot is given in Fig. 19.

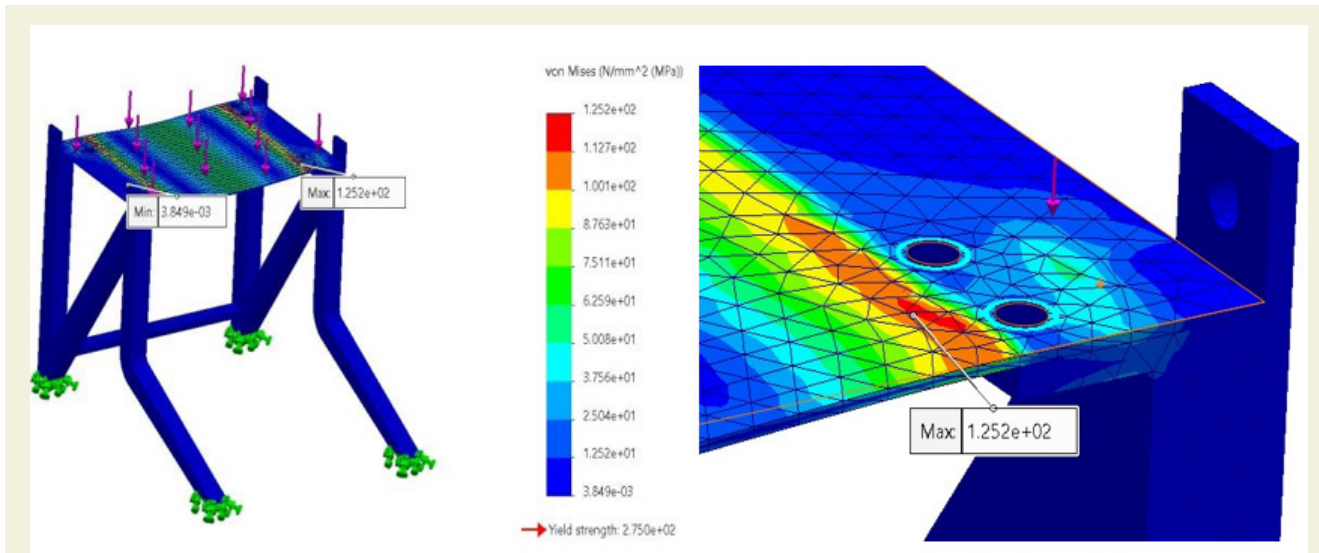

Figure 18. Stress analysis (simulation 2): left- full 3-D contour plots, right - zoom in to connection points.

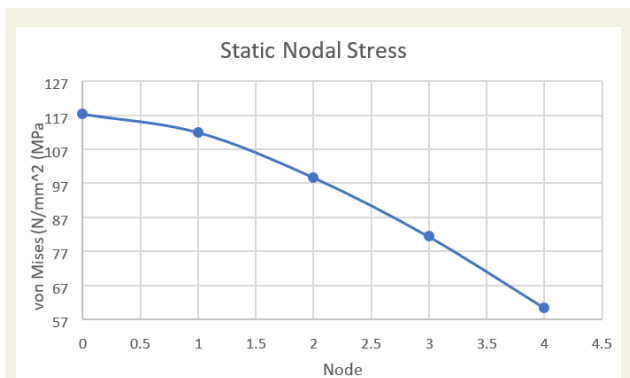

Figure 19. Factor of safety plot for simulation 2.

7.2-2 Displacement Analysis (Y-Component of Displacement).

As for simulation 2, we utilize the Y-component of the displacement as it is the controlling factor for failure of the material (AL6061-T6(SS)). Fig. 20 displays the displacement contour plot. Fig. 21 depicts the associated static displacement plot. The displacement criteria as elaborated earlier has to be satisfied for the maximum Y-Component displacement value to be smaller than 0.01 of the width of the aircraft seat base. For simulation 2, we therefore repeat the calculations to verify this, with the appropriate material data:

$$\text{max. } y\text{-component of displacement} < \frac{1}{100} \text{ of } (width \text{ of seat base})$$

(width of seat base)

width of seat base, $W = 383\text{mm}$

max. y -component of displacement of seat base = 0.0662mm

$$\frac{1}{100} * 383 = 3.83 \text{ mm}$$

$$0.0662 < 3.83 \tag{8}$$

Therefore, the displacement criteria are also satisfied for simulation 2.

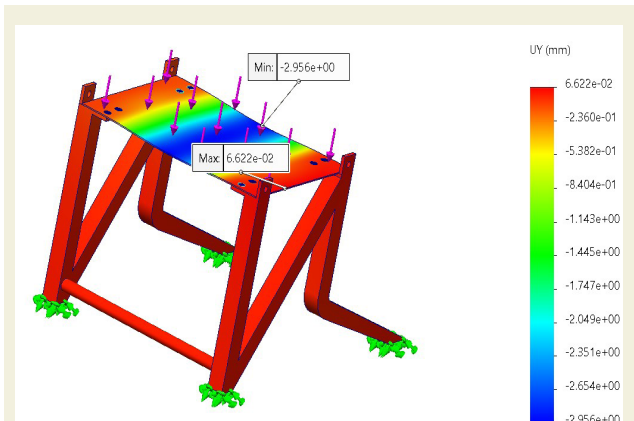

Figure 20. Y-Component of displacement- simulation 2.

7.2-3 Factor of safety (Reserve Factor)

Fig. 22 shows the contour plot for factor of safety analysis in simulation 2. Fig. 23 illustrates the factor of safety distribution plot for simulation 2. Table 6 summarizes the results extracted from the finite element analysis for Simulation 2 i. e. AL6061-T6(SS).

7.3. Simulation 3 - KYDEX®T

Table 7 shows the specifications for the 2 spreaders, seat base and connection rod. The seat foam as before is not analysed.

Table 5. Seat model component materials used in simulation 2.

Component	Material
Spreaders	AL6061-T6(SS)
Seat Base	AL6061-T6(SS)
Connection Rod	AL6061-T6(SS)

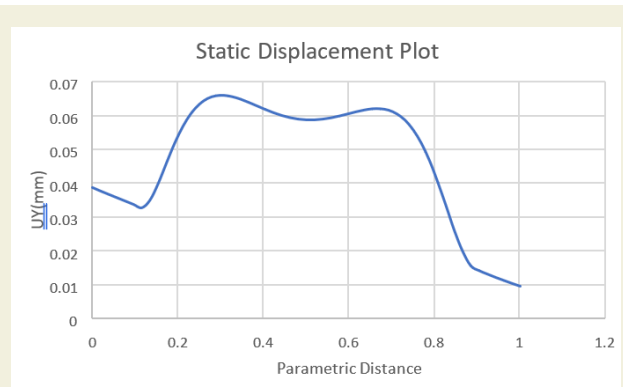

Figure 21. Static displacement plot (simulation 2)

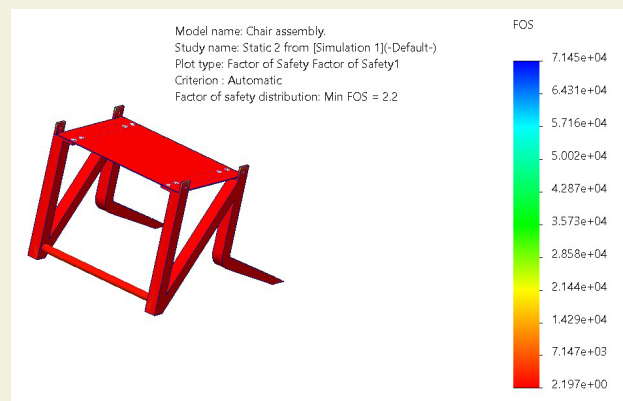

Figure 22. Failure Criteria (factor of safety) computed In SOLIDWORKS for simulation 2

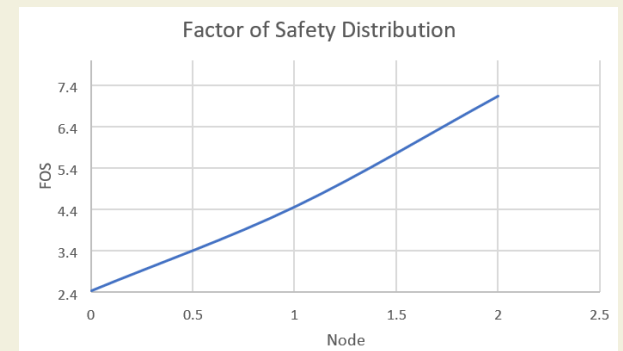

Figure 23. Factor of safety plot for simulation 2.

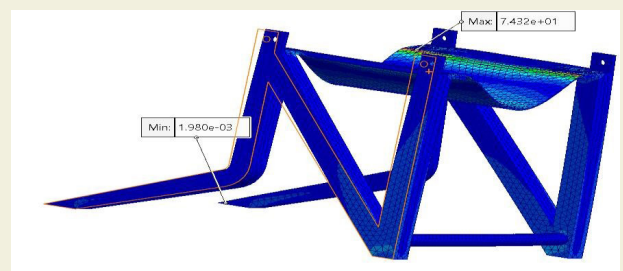

Figure 24. Total deformation contour plots (simulation 3)

Table 6. Summary of simulation 2 - outputs with associated cost estimation

Properties	Values
Max. Stress	1.252e+02 N/mm ²
Min. Stress	3.857e-03 N/mm ²
Max. Y-component of displacement	0.0662 mm
Factor of Safety	2.197
Total Mass	2.32kg
Price	\$2.228/kg

Table 7. Seat model component materials used in simulation 1.

Component	Material
Spreaders	KYDEX®T
Seat Base	KYDEX®T
Connection Rod	KYDEX®T

Table 8. Summary of stress analysis, displacement and other results (simulation 3)

Properties	Values
Max. Stress	7.432e + 01 N/mm ²
Min. Stress	1.980e – 03 N/mm ²
Max. Y-component of displacement	10.04mm
Factor of Safety	0.57
Total Mass	1.6kg
Price	\$51/kg

For brevity, in this 3rd simulation we do not give the entire finite element results as in simulations 1 and 2; instead, we have summarized the total deformation in Fig. 24 and the key results again are documented in Table 8.

7.4. Simulation 4 – combined material design

7.4-1 Stress Analysis - Von-Mises Stress

Table 9 shows the specifications for the 2 spreaders, seat base and connection rod. The seat foam once again is omitted in the finite element simulation. Fig. 25 visualizes the 3-D Von Mises stress distribution.

Table 9. Seat model component materials used in simulation 4.

Component	Material
Spreaders	AL7075-T6(SN)
Seat Base	KYDEX®T
Connection Rod	AL6061-T6(SS)

The static nodal stress plot is given in Fig. 26.

7.4-2 Displacement Analysis (Y-Component of Displacement)

As for the other simulations, we utilize the Y-component of the displacement as it is the controlling factor for fail-

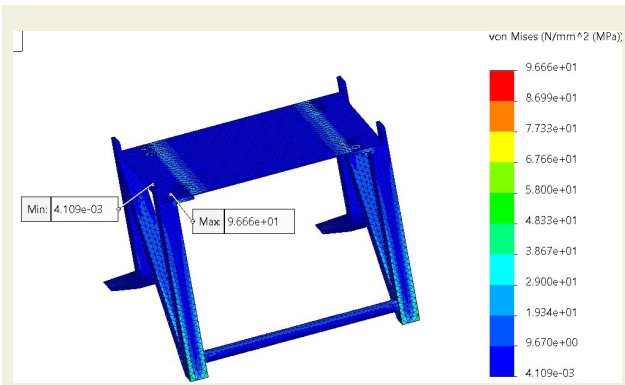

Figure 25. 3-D Von Mises stress contour plot (simulation 4).

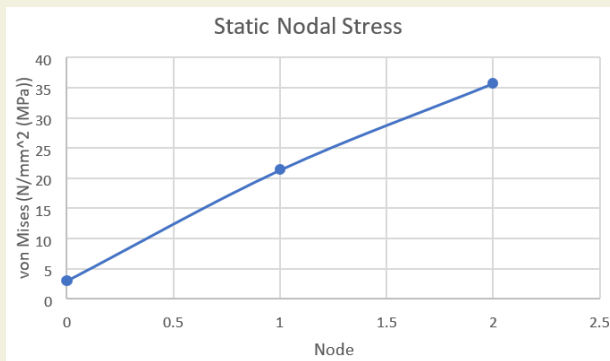

Figure 26. Static nodal stress (simulation 4)

ure of all the materials deployed in this final case. Fig. 27 shows the displacement contour plot. Fig. 28 depicts the associated static displacement plot. The displacement criteria, as elaborated earlier had to be satisfied, for the maximum Y-Component displacement value to be smaller than 0.01 of the width of the aircraft seat base. For simulation 4, again the same calculations are executed to verify this, with the appropriate material data:

In this case, the following calculations are used:

$$\text{max. } y\text{-component of displacement} < \frac{1}{100} \text{ of (width of seat base)}$$

$$\text{width of seat base, } W = 383\text{mm}$$

$$\text{max. } y\text{-component of displacement of seat base} = 1.301\text{mm}$$

$$\frac{1}{100} * 383 = 3.83\text{mm}$$

$$1.301 < 3.83 \quad (9)$$

Evidently this confirms that the displacement criteria are also satisfied for simulation 4.

7.4-3 Factor of safety (Reserve Factor)

Fig. 29 depicts the contour plot for factor of safety analysis in simulation 4. Table 10 summarizes the results extracted from the finite element analysis for Simulation 4 i. e. with all three materials utilized for different seat components.

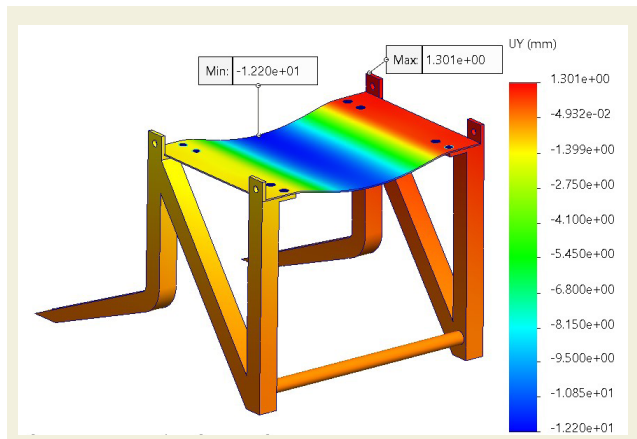

Figure 27. Y-Component of Displacement (simulation 4).

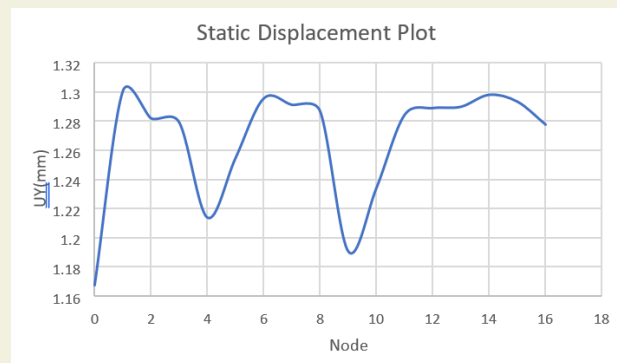

Figure 28. Static displacement plot (simulation 4)

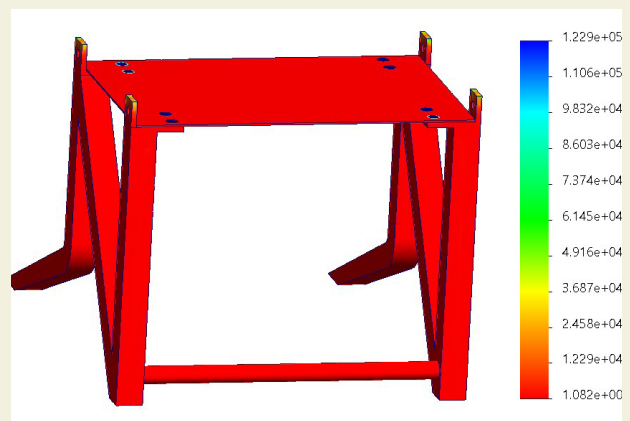

Figure 29. Failure Criteria (factor of safety) computed In SOLIDWORKS for simulation 4.

Finally in Table 11, we present a comparison of the main results for all 4 simulations conducted in SOLIDWORKS.

To provide the most suitable material recommendations for a certain application, it is essential to consider many elements such as safety, displacement, and overall mass for each simulation. The objective is to identify a material that offers a favourable equilibrium between safety (higher safety factor), minimum displacement (lower Y-Comp of Displacement) and an appropriate overall mass.

Table 10. Summary of stress analysis, displacement and other results (simulation 4)

Properties	Values
Max. Stress	9.666e+01 N/mm ²
Min. Stress	4.109e-03 N/mm ²
Max. Y-component of displacement	1.301 mm
Factor of Safety	1.1
Total Mass	2.3kg

Table 11. Summary of all 4 SOLIDWORKS simulations

SIMULATIONS	FACTOR OF SAFETY	Y-COMP OF DISPLACEMENT	TOTAL MASS
SIMULATION 1	4	0.0606 mm	2.32kg
SIMULATION 2	2.2	0.0662 mm	2.32kg
SIMULATION 3	0.57	10.04mm	1.6kg
SIMULATION 4	1.1	1.301 mm	2.3kg

- a) Factor of safety: Typically, larger values are favoured due to their association with a greater margin of safety. Simulation 1 exhibits the greatest factor of safety, with a value of 4. It is followed by Simulation 2, which has a factor of safety of 2.2. Following this, Simulation 4 demonstrates a factor of safety of 1.1, while Simulation 3 exhibits the lowest factor of safety, with a value of 0.57.
- b) Y-Comp of Displacement: Smaller numbers are preferable as they indicate a lower degree of deformation or displacement. Simulation 1 exhibits the lowest displacement value of 0.0606 mm, while Simulation 2 follows with a displacement of 0.0662 mm. Simulation 4 displays a displacement of 1.301 mm, while Simulation 3 has the highest displacement value of 10.04 mm.
- c) Total Mass: Lower total mass is preferable since it helps keep the structure light and cheap. Here, Simulation 3 weighs in as the lightest at 1.6 kg, followed by Simulations 1 and 2 at 2.32 kg each, and finally, Simulation 4 at 2.3 kg.

Considering all these criteria, Simulation 1 emerges as the most prominent option due to its superior factor of safety, minimized displacement and comparable overall mass in comparison to Simulation 2. Hence, if the key considerations revolve around safety and minimum displacement, it can be concluded that Simulation 1 would be the most suitable option. Therefore, AL7075-T6(SN) is the best material selection and is considered for the subsequent topology optimization analysis.

8. Topology Optimization

In Simulation 1, the choice of AL7075-T6(SN) as the optimal design material inspires the objective to optimize the design to improve its structural durability, minimize deformation and also optimize the total mass while up-

holding safety standards. The primary aim is to achieve the best capabilities of the selected material via the optimization of its topology. This entails ensuring that the material is employed in the most efficient way possible, surpassing safety standards while simultaneously minimizing deformation and weight.

8.1. Loading Simulation for single component

To begin the process of topology optimization, the first step involves simulating the application of a 750N remote load on the airplane seat spreader i. e. a single component of the seat. SolidWorks software provides the capability to accurately specify the load conditions, including both the orientation and amplitude of the applied force. In this scenario, the load is executed with the purpose of replicating real-world circumstances, hence guaranteeing the spreader ability to endure the stresses that it would encounter.

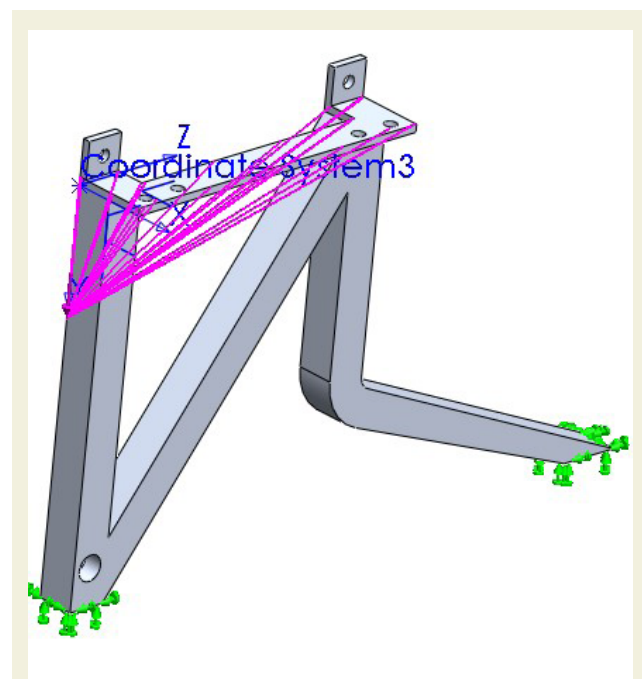

Figure 30. Remote load application.

8.2. Meshing

The same meshing procedure is repeated during the topology optimization process to refine the structure.

8.3. Topology Optimization Analysis:

After the load and material characteristics have been determined, SolidWorks proceeds with conducting a topology optimization study. The computational approach used in this study involves the iterative evaluation of various material distribution scenarios within the design space of the spreader. The objective is to selectively eliminate material from areas with lower stress concentrations while simultaneously strengthening sections that are exposed to greater stress levels. The result of this research is a structural design that effectively reduces weight while also ensuring the necessary structural integrity to endure the applied load. The final design will

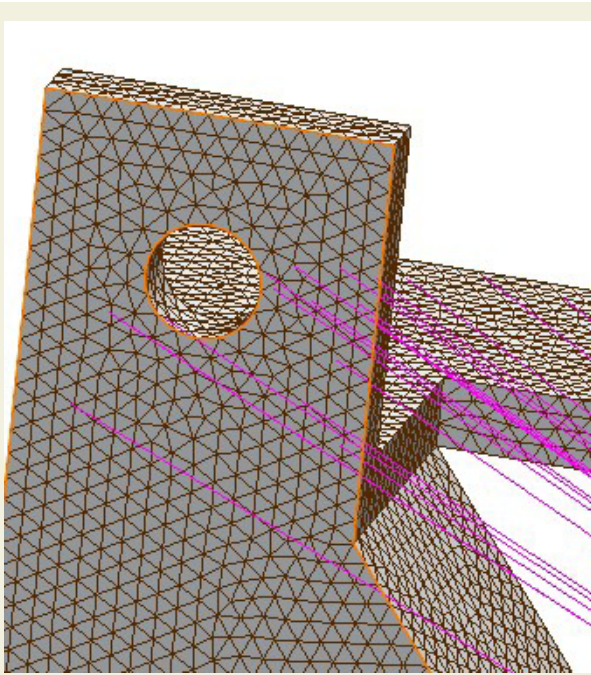

Figure 31. Meshed structure.

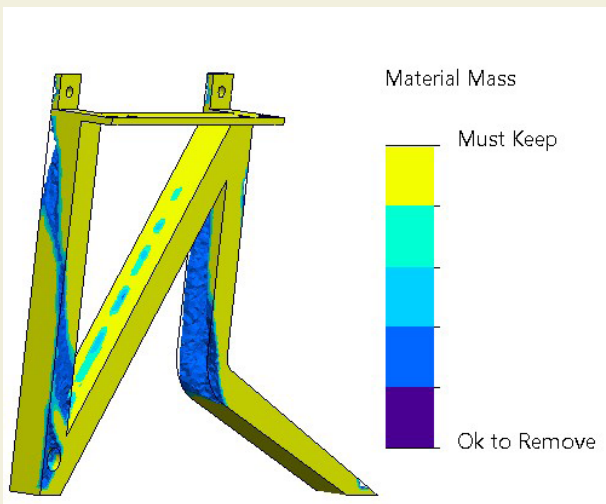

Figure 32. Topology visualization.

demonstrate a refined distribution of material, prioritizing regions that are essential for supporting loads. The results are summarized in Table 12.

Table 12. Topology optimization simulations

Study Name	Topology optimization
No. of Nodes	23049
Number of Elements	108606
Total Simulation Time	00:06:49
Mass Reduction	30%

8.4. Visualization and Results

The improved design can be seen using SolidWorks' visualization capabilities (Figure 32). Stress distribution patterns, regions where material has been removed, and weak spots can all be analysed. The design may be thor-

Table 13. Topology optimization-key results for simulation 1 material choice (AL7075-T6(SN))

Properties	Values
Max. Stress	1.894e+02 N/mm ²
Min. Stress	6.357e-04 N/mm ²
Max Y-component of displacement	0.0543 mm
Factor of Safety	2.666
Total Mass	1.89kg
Price	\$2.304/kg

oughly tested and improved to ensure it is secure and functional.

The results after topology optimization of Simulation 1 (AL7075-T6(SN)) are given in Table 13 below.

8.5. Improved Design

The optimized design is shown for simulation 1 above in Figure 33.

8.6. Comparison

Table 14 summarizes the comparison for the original simulation 1 and new topologically optimized computations. In Simulation 1 of AL7075-T6(SN), structural analysis showed remarkable findings. The material had a maximum stress of 125.2 N/mm² and a minimum stress of 0.0039 N/mm². Due to its strong 4.034 factor of safety, the component may have been over-engineered for its intended use. However, at 2.32 kg, the component's mass and \$2.304/kg material cost showed a high design cost. The maximum Y-component of displacement was 0.0606 mm, which was acceptable but could have been optimized to decrease material use and expense without affecting structural integrity. After performing topology optimization on Simulation 1 of AL7075-T6(SN), several



Figure 33. Improved design via topological optimization for simulation 1.

improvements have been achieved. The maximum stress sustained by the component has been elevated to 189.4 N/mm². However, it is worth noting that the minimum stress has also risen, although to a negligible value of 0.0006 N/mm². The compromise in this scenario is characterized by a fall in the factor of safety to 2.666, suggesting a design that is more optimal but possibly associated with more risk. The most notable improvements, however, concern weight reduction. The overall mass of the component saw a substantial reduction, reaching 1.89 kg, which represents a notable improvement on the original design. This suggests that there may be significant cost reductions in terms of material prices, as well as lower inertial loads and improved handling.

Table 14. Comparison of original simulation 1 and topology optimization results for simulation 1 - material choice (AL7075-T6(SN))

Properties	Initial Design	Optimized Design
Max. Stress	1.252e+02 N/mm ²	1.894e+02 N/mm ²
Min. Stress	3.857e-03 N/mm ²	6.357e-04 N/mm ²
Max Y-component of displacement	0.0606 mm	0.0543 mm
Factor of Safety	4.034	2.666
Total Mass	2.32kg	1.89kg

8.7. Fully Assembled Optimized Design

Following the single component (spreader) topological optimization, a second fully assembled structural seat case has also been optimized, again for simulation 1. This is visualized in Figure 34 and elaborated upon in the next section.

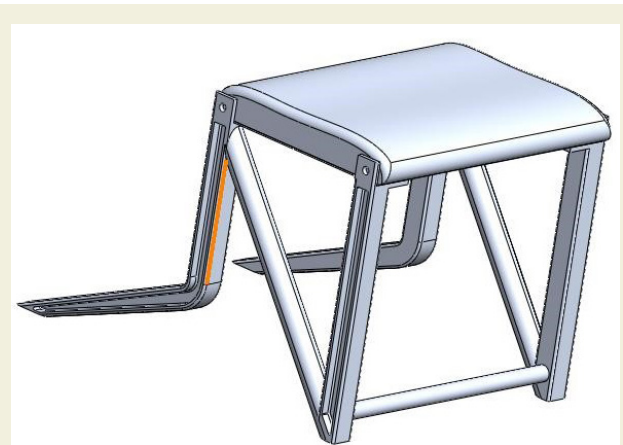

Figure 34. Fully Assembled Optimized Seat Frame (for simulation 1-AL7075-T6(SN)).

9. Discussion

This article has examined the static stress analysis of an aircraft seat. The work focuses primarily on 3-D modeling, static stress analysis and topology optimization studies and their outcomes. In this research, Acro Aircraft Seating Company provided the aircraft seat model to be analysed. In the next stage of the study, model preparation studies for the seat's static analysis have been initiated. Prior to analysing the seat components with the FEA technique, a mesh analysis was conducted. This is one of the most crucial steps of model preparation by far. Since

the mesh quality and mesh size are crucial for the created model to achieve convergence to the correct results, they must be carefully considered. After setting the proper mesh parameters for the analyses, the boundary conditions and determined loads for the seat were established. Next, the intended materials for the designed seat were inputted into the SOLIDWORKS program, and materials were designated to the seat parts. Thereafter, the model is defined with the required solution methodologies. The model was then run, and the results are visualized.

9.1. Static Analysis

The results derived from the static analysis demonstrate that the stress and strain values obtained from the calculations were found to be within the anticipated range for static analysis. Upon evaluation of the obtained findings, it becomes apparent that the maximum anticipated stress level reaches around 189 MPa. Upon examination of the yield strength and tensile strength properties of the material used, it was noted that the stress values exhibited a substantial difference when compared to the strength values. Based on the findings obtained from the analysis, it can be concluded that the aircraft seat design successfully satisfying the requirements of static analysis criteria.

9.2. Topology Optimization

Topology optimization plays a crucial role in the context of airplane seats because of the significant cost implications associated with the weight of flight-related parts within the aviation sector. Within this context, each instance of weight reduction work that is carried out, while still adhering to the necessary strength limitations of the seat, results in a financial benefit. To achieve this objective, research on topology optimization has been undertaken for the rear seat leg (spreader), a critical component influencing the overall weight of the seat. The topology optimization procedure was iteratively performed using three objective functions. The findings from the topology optimization investigations have shown that the structural integrity of the CAD model under consideration can be maintained even after the removal of 30% of the original material. This suggests that the FE approach proposed in this study may be successfully used for aircraft seat design. Based on the findings, it can be said that the use of topology optimization in the research yields a weight and material reduction of 30% for the seat leg. The use of computer-aided engineering design tools in this investigation has underscored the significance of their efficient application in the design of crucial engineering structures. These tools not only contribute to weight reduction but also provide a decrease in product development duration. Furthermore, they offer valuable insights into seat design.

10. Conclusions

In this article, SOLIDWORKS finite element stress analyses were performed to examine the structural integrity of an aircraft seat. The results of these analyses were visualized carefully. The comparison between the finite element (FE) analysis findings of various aerospace mate-

rials demonstrates a satisfactory analysis, hence enhancing the level of trust in the accuracy and reliability of the finite element method (FEM). Nevertheless, it is worth noting that some analysis phases may benefit from a more complete approach, and there is potential for doing future research to further enhance the depth of analysis. For the current study, the loads identified as the boundary condition in the topology optimization were deemed acceptable. This acceptability was achieved by the incorporation of supplementary loads in conjunction with the loads derived through statistical analysis. In the preceding phase, prior to conducting topology optimization, the inclusion of dynamic analysis with static analysis would enable the determination of *more precise boundary conditions* for the purpose of topology optimization. Topology optimization has also yielded approximate outcomes; however, as previously indicated, further efforts may be undertaken to generate even higher precision. Another concern is the potential development of a novel design after the completion of topology optimization. In the present context, after the completion of the topology optimization analysis, the acquired results may be transferred to computer-aided design (CAD) software to generate a novel CAD model. This implies that it is possible to do an engineering-design iteration. It is important to note that the results derived from the present finite element analysis would of course in industrial manufacturing require validation by physical experimentation. It is acknowledged that, despite the reliability and accuracy of the present findings it is necessary to subject the proposed aircraft seat design to physical testing to ascertain the validity of the SOLIDWORKS finite element modelling,

prior to implementation of the seat design as a finalized product. Additionally, since in the present simulations, the foam seat was ignored (due to negligible contribution to structural integrity), however, in future studies it may be incorporated using a suitable hyper-elastic material model in SOLIDWORKS or indeed other FEA codes e. g. ANSYS. Dynamic loading of the seat with human occupants may also be achieved using MATLAB SIMULINK approaches. Efforts in these directions are currently underway and will be communicated imminently.

Research Ethics

Ethical approval not required.

Author Contributions

The author(s) accept full responsibility for the content of this article and have approved its submission.

Competing Interests

The author(s) declare that there are no competing interests.

Research Funding

Not reported.

Data Availability

Not applicable.

References

- [4] Sriram, T. C. (2018). Effect of Anthropometric Variability on Middle-Market Aircraft Seating. *International Journal of Aviation, Aeronautics, and Aerospace*, 5(1), 7. <https://doi.org/10.15394/ijaaa.2018.1208>
- [5] Caputo, F., De Luca, A., Marulo, F., Guida, M., & Vitolo, B. (2018). Numerical-experimental assessment of a hybrid FE-MB model of an aircraft seat sled test. *International Journal of Aerospace Engineering*, 2018, 8943826. <https://doi.org/10.1155/2018/8943826>
- [6] Bhonge, P., & Lankarani, H. (2008). Finite element modeling strategies for dynamic aircraft seats. *SAE Technical Paper*, 2008, 2272. <https://doi.org/10.4271/2008-01-2272>.
- [7] Alexander, R. (1997). Building Composite Aircraft Part 1. Retrieved from Experimental Aircraft Association: <https://www.eaa.org/eaac/aircraft-building/builderresources/while-youre-building/building-articles/composite/building-composite-aircraft-part-1#:~:text=Three%20types%20are%20used%20most,varying%20physical%20characteristics%20and%20cost.>
- [8] Bilezikjian, V. (1996). U.S. Patent No. 5,553,923. Washington, DC: U.S. Patent and Trademark Office.
- [9] Ahmadpour, N., Lindgaard, G., Robert, J. M., & Pownall, B. (2014). The thematic structure of passenger comfort experience and its relationship to the context features in the aircraft cabin. *Ergonomics*, 57(6), 801-815. <https://doi.org/10.1080/00140139.2014.899632>
- [10] Bouwens, J., Tsay, W. J. J., & Vink, P. (2017). The high and low comfort peaks in passengers' flight. *Work*, 58(4), 579-584. <https://doi.org/10.3233/WOR-172637>
- [11] Alan, G., & Hanser, V. (2009). Finite element analysis. In: Gent, A.N. (Ed.), *Elasticity in Engineering with Rubber*. In R. Finney, *How to design Rubber components* (pp. 36-46).
- [12] Hwang, H. Y., Choi, K. K., & Chang, K. H. (1997). Second-order shape design sensitivity using P-version finite element analysis. *Structural optimization*, 14, 91-99. <https://doi.org/10.1007/BF01812510>
- [13] Nayroles, B., Touzot, G., & Villon, P. (1992). Generalizing the finite element method: diffuse approximation and diffuse elements. *Computational mechanics*, 10(5), 307-318. <https://doi.org/10.1007/BF00364252>
- [14] Meola, C., Boccardi, S., & Carlomango, G. (2017). *Infrared Thermography in the Evaluation of Aerospace Composite Materials. Composite Materials in the Aeronautical Industry*, 1-24.
- [15] Atkinson, K. (1991). *An introduction to numerical analysis*. John Wiley & sons.
- [16] Brauer, J. (2010). What Every Engineer Should Know About Finite Element Analysis. In *Finite Element Analysis* (pp. 36-40).
- [17] Kassapoglou, C. (2013). *Design and analysis of composite structures: with applications to aerospace structures*. John Wiley & Sons.
- [18] Cook, R. (1995). *Finite Element Modeling for Stress Analysis*. New Jersey.
- [19] Bhonge, P. (2016). *Methodology for Aircraft Seat Certification by Dynamic Finite Element Analysis*. Wichita State University.