





Adaptation of Artificial Intelligence Literacy Scale: Latent Profile Analysis

Ali Kırksekiz¹ 
Mehmet Yıldız² 
Mübin Kıyıcı³ 
Metin Yıldız^{1*} 

¹ Sakarya University of Applied Sciences, Sakarya, Türkiye, alik@subu.edu.tr
yildiz.metin@gmail.com

² Atatürk University, Department of Computer Education and Instructional Technology, Erzurum / Sakarya University of Applied Sciences, Sakarya, Türkiye, mehmetyildiz@subu.edu.tr

³ Sakarya University, Sakarya, Türkiye, mkiyici@sakarya.edu.tr

Received: 06.05.2024
Accepted: 19.11.2024
Available Online: 15.12.2024

Abstract: Artificial intelligence literacy is vital for individuals' adaptation to the future workforce and societal changes by enabling them to understand and effectively use AI technologies and critically evaluate their impact on society. In this study, the validity and reliability of the artificial intelligence literacy scale in Turkish language were tested and the latent profiles of the students were determined. This methodological study was carried out with a total of 729 students between December 2023 and February 2024. Validity and reliability analyses were conducted with SPSS 27 and AMOS 24, and latent profile analysis was handled with R programming language. According to the results of the CFA analysis of the Artificial Intelligence Literacy Scale, the fit indices were found to be significant ($X^2/sd= 3.832$, $RMSEA=.062$, $CFI=.949$, $AGFI=.933$, $GFI=.960$, $NFI=.949$, $TLI=.928$, $IFI=.916$). Considering the Cronbach Alpha value of the scale consisting of 4 sub-dimensions and 12 items, the internal consistency coefficient was found to be 0.814. Since the lowest BIC value in the latent profile analysis was found in the VVV model, the VVV model was considered as the appropriate one in the study, and the class analyses were carried out through this model. With the LPA analysis, it was designated that the scale was divided into 3 classes. It was determined that the Artificial intelligence literacy scale is a valid and reliable measurement tool. After latent profile analysis, it was found out that the scale was divided into 3 classes.

Keywords: Artificial Intelligence, Literacy, Scale Adaptation, Latent Profile Analysis.

1. Introduction

The advancements in computer and internet technologies have introduced a variety of competencies that are essential for individuals, not only in their everyday activities but also to be deemed as skilled workers in the modern labor market. These essential skills are identified as computer literacy, technology literacy, information literacy, internet literacy, and media literacy. However, nowadays, these literacies, which have high levels of interrelationship with each other, are also directly related to digital literacy. Digital literacy broadly refers to the capability to effectively find, organize, comprehend, utilize, communicate, assess, and generate information using digital technologies in a safe and appropriate manner (Law et al., 2018). In terms of its definition, digital literacy can also be regarded as a set of relationships between the knowledge, skills and competencies that individuals should have in responding to the challenges that arise as rapid developments in technology become more effective at every stage of life (McMillan, 2021). Innovations emerging as a result of rapid developments in technology come along with some knowledge, skills and competencies that individuals should have, which leads to the emergence of new literacies.

Artificial Intelligence (AI) is a technology that has ignited significant debate due to its diverse range of products and applications. AI represents the capability of machines to mimic human cognitive functions, including learning, reasoning, and problem-solving, which positions it at the forefront of technological advancement and discussion (Liu et al., 2021; Xu, 2023). AI, which began to come forefront with discussions about digital and human computers at the Paris conference in 1951 (Bruderer, 2016) and was first expressed by John McCarthy (Moloi and Marwala; 2021), has led to revolutionary

transformations in many sectors from health to education, finance to law, entertainment to agriculture (Danry et al, 2022; Davenport and Kalakota, 2019; Drach et al., 2023; Minbaleev, 2022; Yin and Moore, 1987; Ruiz-Real et al., 2020). While many people hold favorable opinions about the use of artificial intelligence technologies due to their substantial benefits, it is also necessary to acknowledge potential risks and threats related to information security and ethics (Khawlah et al., 2023). Particularly, the difficulty of confirming whether a piece of information is produced by artificial intelligence can cause some problems both in the context of information security and ethics.

It may be estimated that AI will transform many labor qualifications in the near future and may even lead to the extinction of many occupational groups, since it has the potential to have a transformative impact in various sectors, including business and human life (Davenport and Kalakota, 2019; Garingan and Pickard, 2021; Puspitaningsih et al., 2022). Hence it can be argued that it is a vital issue, in the context of the competitiveness of individuals, businesses and even countries, to increase the ability of people to produce work with these technologies by including AI technologies in teaching processes in the matter of training qualified labor force. Many scientists carry out scientific research examining the effects of teaching processes enriched with AI technologies on learners in various contexts (Voulgari et al., 2021). With reference to the findings of these studies, it is visible that many countries have developed policies in the context of using AI technologies in teaching processes at all levels starting from early childhood, and developing the knowledge, skills and competencies of learners on how to produce solutions to their own problem situations with these technologies (Puspitaningsih et al., 2022; Williams et al., 2019).

Adapting to the transformation brought about by AI technologies will be possible with individuals possessing high levels of literacy in this field. AI literacy is of great importance for today's digitalized world as it enables individuals to use AI technology to solve problems, encourage analytical, critical and metacognitive thinking, and prepare them for the future (Defeng & Xiaojie, 2020; Puspitaningsih et al., 2022). Additionally, it is crucial to assess the Understanding the AI literacy levels of individuals is crucial. Knowing how a user's proficiency with AI technology affects interactions between humans and AI can help designers create applications that are tailored to the AI literacy levels of their target audience (Wang et al., 2022).

While AI introduces new benefits and opportunities, the biases inherent in these technologies also raise important concerns about ethics and security (Brendel et al., 2021; Wang and Siau, 2019). Individuals need proper training to ensure they use AI responsibly and effectively safeguard their own interests and privacy (Kong et al., 2021). Gaining knowledge, skills, and values related to AI is becoming crucial for individuals. This foundational AI literacy is essential for facilitating effective interactions between humans and machines across social settings, educational spaces, and professional environments (Ali et al., 2019). Within the scope of the study, a latent profile analysis was carried out to determine which policies should be implemented for specific individuals and what types of training should be provided. Latent profile analysis stands out as an effective method to reveal the knowledge levels of individuals on artificial intelligence in the context of different dimensions and to reveal variations.

It is seen that there is a limited number of measurement tools to measure AI literacy in the literature (Laupichler et al. 2023). In Turkey, there is no measurement tool for determining artificial intelligence literacy for university students. Students' AI literacy can help them understand and manage AI technologies and provide useful information about future job opportunities and career paths. Scale adaptation makes the quantitative measurement of concept of individuals in the current language valid and reliable (Büyüköztürk, et al., 2013). The current study was conducted to address the lack of existing scales in the literature and to perform a latent profile analysis. In the related literature, there are scales developed to determine individuals' AI literacy in various contexts (Ferikoğlu & Akgün, 2022; Hornberger et al., 2023; Hwang et al., 2023; Seong-Won & Lee, 2022). This study aims to bridge this gap

by adapting the artificial intelligence literacy scale developed by Wang et al. (2023) into Turkish. It is anticipated that the scale to be obtained can be used as a data collection tool in the needs analysis phase of instructional designs to be realized for all kinds of instructional activities which will be planned to improve the knowledge, and competencies of individuals studying at higher education level on artificial intelligence technologies.

2. Method

In this study, the AI literacy scale was adapted into Turkish and then a latent profile analysis was conducted. The study was carried out between December 2023 and February 2024.

2.1 Population and Sample of the Research

The study group of the research, which was selected by convenient sampling method, consists of 729 people at Sakarya University of Applied Sciences. In the convenience sampling method, the researcher selects the most accessible sample that offers the greatest savings in time and resources, continuing this approach until a sufficient sample size is achieved (Büyüköztürk, et al., 2013). Due to the fact that the scale is an adaptation study, only Confirmatory factor analysis is considered sufficient (Seçer, 2015). Confirmatory factor analysis is the preferred method for examining the model fit of a scale's factor structure in its original language during the adaptation of a measurement tool developed in another language into Turkish (Seçer, 2015).

Literature reviews reveal varying opinions on the appropriate sample size for scale development and adaptation processes. Bryman and Cramer (2001) advise that the sample size for analysis should be five to ten times the number of items on the scale, while Tabachnick and Fidell (2007) advocate for a minimum of 300 participants, independent of the number of items. In this study, we engaged 729 participants, significantly exceeding the recommended guidelines. This robust sample size, which is at least 20 times the number of items, provides a solid foundation for validating the reliability and accuracy of the research, far surpassing the advised minimum of 300 participants.

2.2 Data Collection Instruments

2.2.1 Personal Information Form

This form, which was developed by the researchers, consists of questions investigating the demographic characteristics of the individuals.

2.2.2 Measuring User Competence in Using Artificial Intelligence

In this study, the scale developed by Wang et al. (2023) was adapted into Turkish. The aim of the original scale was to develop a valid and reliable scale to measure AI literacy of individuals from different age groups. The original scale consists of 4 sub-dimensions: Awareness, Usage, Evaluation and Ethics. Some of the scale items are; "I can distinguish between smart devices and non-smart devices", "I can skillfully use AI applications or products to help me with my daily work", "I can evaluate the capabilities and limitations of an AI application or product after using it for a while", "I always comply with ethical principles when using AI applications or products". The scale is originally a 7-point Likert-type scale consisting of 12 items and 4 sub-dimensions. The scale is scored as Strongly Disagree=1, Disagree=2, Partly Disagree=3, Neutral=4, Partly Agree=5, Agree=6 and Strongly Agree=7. Items 2, Item 5 and Item 11 in the scale are reverse items. The highest score that the person to whom the scale is applied is 84 and the lowest score is 12.

2.2.3 Language Equivalence Studies of the Scale

Scale Language Equivalence Studies are vital to ensure that versions of a scale or questionnaire in different languages function similarly. These studies test whether the concepts that the scale measures in the original language accurately measure the same concepts in the target language. An effective

language equivalence study increases the validity and reliability of the scale so that research results are comparable across different cultural and linguistic groups. Therefore, scale language equivalence studies are particularly important in international research and in measurements administered in multilingual communities. In this scale adaptation study, the "process of translation and adaptation of instruments" recommended by WHO was followed (WHO, 2015). Upon securing authorization to use the scale, the original version was independently translated into Turkish by a bilingual linguist and three academics proficient in English who specialize in the field of artificial intelligence. Then a single text in Turkish was created with the equivalents that best represent each item in the scale. The questions of the Turkish form were checked for semantic integrity by 2 experts who know both source language (English) and target language (Turkish). Finally, the Turkish form was back-translated by a linguist who did not participate in the translation in the first stage and 2 academicians who know both languages. Then the original version was compared with the adapted version by 3 academicians specialized in artificial intelligence.

2.3 Content Validity

The content validity rate (CVR) of each item in the scale was calculated institutions (Yeşilyurt, & Çapraz, 2018). The draft scale, which was finalized after the experts' opinions, was applied to 15 students before it was applied to the study sample group. In line with the suggestions received, the scale was evaluated in accordance with the words of the Turkish Language Association in terms of Turkish language and cultural differences. Then 107 students were piloted in the study and the final version of the scale was reached.

2.4 Ethical Considerations

Ethics committee permission for this study was obtained from Sakarya University of Applied Sciences Ethics Committee of Rectorate with the decision dated 11.12.2023 and numbered 39, after receiving permission by e-mail from the researchers who developed the original scale. This study was conducted in accordance with the *Principles of the Declaration of Helsinki*.

2.5 Statistical Analysis

IBM Statistical Package for Social Science (SPSS) version 27.0 and IBM SPSS Amos version 24.0 were used for data analysis. R programming language was used for latent profile analysis of the scale.

3. Findings

3.1 Structure Validity

The path followed in the adaptation of the scale is displayed in Figure 1.

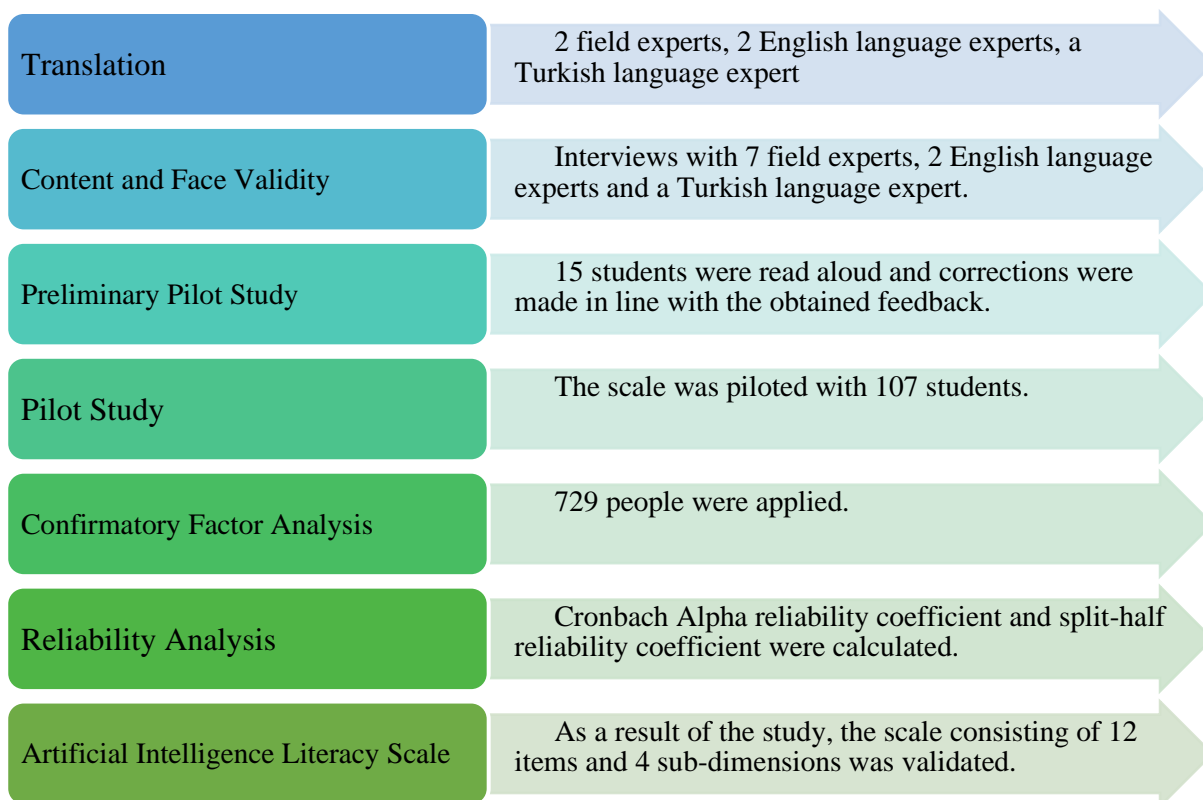
Figure 1*Adaptation Process***3.1.1 Data Analysis**

In this context, descriptive statistics of the study group are given in Table 1.

Table 1*Descriptive Statistics for the Sample Group*

		Confirmatory Factor Analysis	
		f	%
Gender	Male	422	57.9
	Female	307	42.1
Education Level	Associate Degree	288	39.5
	Bachelor's Degree	385	52.7
	Post-Graduate Degree	57	7.8
Department	Health Sciences	127	17,4
	Computer Programming	115	15,8
	Mechanical Engineering	107	14,7

Computer Engineering	93	12,8
Multidimensional Modeling and Animation	49	6,7
Tourism and Hotel Management	43	5,9
Civil Engineering	38	5,2
Mechanical and Metal Technologies	32	4,4
Mechatronics Engineering	28	3,8
Welding Technology	27	3,7
Accounting and Tax Applications	24	3,3
Electrical and Electronics Engineering	13	1,8
Other	33	4,5
Total	729	100

Table 1 reveals the statistics for the distribution of the groups according to gender, education level and departments.

The Cronbach Alpha value obtained as a result of the application is presented in Table 2.

Table 2

Cronbach Alpha Value of the Preliminary Application of the Scale

Cronbach Alpha	N	Average	Variance	Standard Deviation	Number of Items
0.959	107	5.275	.667	.81	12

Table 2 shows that the Cronbach Alpha value is 0.959. In this regard, it can be stated that the scale is suitable for analysis (Kline, 2011).

3.1.2 Confirmatory Factor Analysis (CFA)

The path diagram of the CFA is presented in Figure 2.

Figure 2

Confirmatory factor analysis path diagram

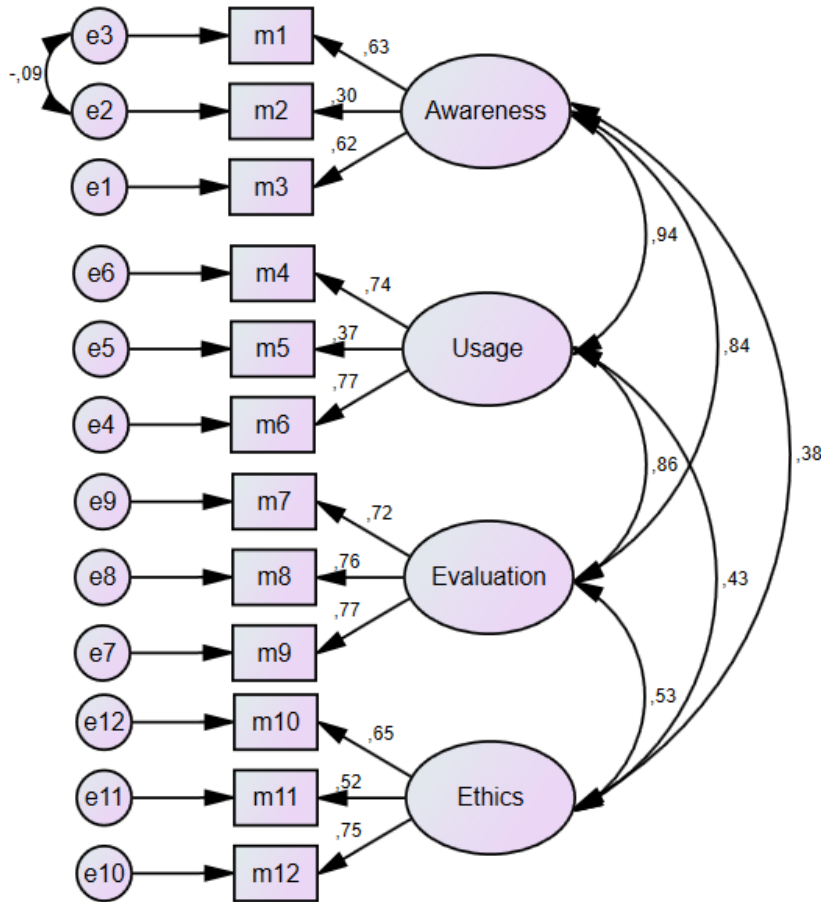

In Figure 2, the factor loadings showing the relationship of each observed variable (m1 - m12) with the related latent construct vary between 0.62 and 0.77. CFA path diagram available in Figure 2, this value is expected to be greater than 0.3, so it was seen that all items met this criterion (Anderson & Gerbing, 1988).

Various goodness-of-fit tests are used to examine the model fit of the scale (McMillan & Schumacher, 2006; Munro 2005; Şimşek 2007; Hooper, Coughlan & Mullen, 2008) are given in Table 3.

Table 3

Confirmatory Factor Analysis Fit Indices

Indices	Reference Value		Measurement	Result
	Acceptable Fit	Good Fit		
CMIN/DF	$3 < \chi^2/sd \leq 5$	$0 < \chi^2/sd \leq 3$	3.832	Acceptable Fit
RMSEA	$.05 \leq RMSEA \leq .08$	$0 \leq RMSEA \leq .05$.062	Acceptable Fit
CFI	$.90 < CFI \leq .94$	$.95 < CFI \leq 1$.949	Acceptable Fit
AGFI	$.85 < AGFI \leq .89$	$.90 < AGFI \leq 1$.933	Excellent Fit

GFI	.85 < GFI ≤ .89	.90 < GFI ≤ 1	.960	Excellent Fit
NFI	.90 < NFI ≤ .94	.95 < NFI ≤ 1	.949	Acceptable Fit
TLI	.90 < TLI ≤ .94	.95 < TLI ≤ 1	.928	Acceptable Fit
IFI	.90 < IFI ≤ .94	.95 < IFI ≤ 1	.916	Acceptable Fit

When Table 3 is examined, it can be concluded that the scale showed a good and acceptable fit.

3.1.3 Correlation Coefficients of Artificial Intelligence Literacy Scale and Sub-Dimensions

Correlation coefficients were calculated to determine the relationship between the Artificial Intelligence Literacy Scale (AILS) and the four factors that make up the scale. Table 4 shows that the correlation coefficient between the factors and the whole scale varies between .66 and .81 and the relationship between the sub-dimensions is positive.

Table 4

Correlation between AILS and subdimensions

	Awareness	Usage	Evaluation	Ethics
AILS	0.75	0.80	0.81	.66

3.2 Reliability Analysis

The results of the calculations are displayed in Table 5.

Table 5

Internal Consistency and Two-Half Reliability Analysis

Test Type		Number of Items	Cronbach Alpha
Literacy Scale		12	0.814
Two-Half	1 st Section	6	0.706
Coefficient	2 nd Section	6	0.746

Table 5 indicates that the internal consistency coefficient of the scale was 0.814. A Cronbach Alpha coefficient of 0.70 and above is considered appropriate (Büyüköztürk, et al., 2013).

3.3 Latent Profile Analysis

Response-based analyses aim to reveal structures that are implicit in the data collected from individuals with the help of scales, in other words, the structures that cannot be directly observed. The analysis technique administered in latent classification analysis varies according to the number of measurements, the type of scale on which the measurement is performed, the number of variables

measured and whether there is variance between classes. The techniques used in classification analysis are available in Table 6.

Table 6

Summary of Techniques Using Latent Class (Muthén, 2001)

Class	Outcome/ Indicator Scale	Number of Time Points	Number Outcome / Time Points	of Within-Class Variation
LCA	Categorical(u)	Single	Multiple	No
LPA	Categorical(y)	Single	Multiple	No
LCGA	Categorical(u) Categorical(y)	Multiple	Multiple	No
LTA	Categorical(u)	Multiple	Multiple Single	No Yes
GMM	Continuous(y)	Multiple	Single Multiple	Yes
GGMM	Categorical(u) Continuous(y)	Multiple	Single Multiple	Yes

LCA – latent class analysis, LPA – latent profile analysis, LCGA – latent class growth analysis, LTA – latent transition analysis, GMM - growth mixture modeling GGMM – general growth mixture modeling

Among the techniques summarized in Table 6, especially LCA and LPA analysis are the most common analysis techniques (Ferguson, Moore & Hull; 2020). While LPA deals with continuous cluster indicators, LCA deals with categorical variables (Pastor, Barron, Miller & Davis; 2007). LPA assumes unobserved heterogeneity and classes with specific sub distributions in indicators (Spurk, Hirschi, Wang, Valero & Kauffeld; 2020). Latent class analysis is a statistical method that models the probability of observing specific response patterns within a dataset. This technique helps to identify unobserved, or latent, subgroups within the data based on the responses given (Vermunt, 2022). Steps in LPA/LCA are as follows (Bauer, 2022):

1. Model specification
2. Class enumeration
3. Substantive interpretation of the target model(s)
4. Include predictors and distal outcomes of most likely latent class membership

LPA is less widely used than other latent variable models and, possibly due to that, has long been only available in specialized software packages such as Mplus (Wardenaar, 2021). In the present study, R language was used for LPA and Mclust library (Scrucca, Fraley, Murphy & Raftery; 2023) was used as a library. In addition, Tidylpa library (Rosenberg, van Lissa, Beymer, Anderson, Schell & Schmidt; 2019) was used to calculate fit indices more easily.

In the model evaluation, the VVV model (ellipsoidal, varying volume, shape, and orientation) emerged as the best working model. Akogul & Erisoglu (2017) advise evaluating BIC values in model selection and selecting the model with the lowest BIC value. After deciding on the model, the second step was to

determine the best class within the model. In the VVV model, up to 3 classes were analyzed and the results are presented in Table 7.

Table 7

LPA Model Fit Indices Summary

Class	Log					LMR		LMR meaning	BLRT Value	BLRT p-value
	Likelihood	AIC	BIC	SABIC	Entropy	Value	p-value			
1	-4196,83	8421,67	8485,97	8441,51						
2	-4076,51	8211,03	8344,23	8252,14	0,78	240,64	0.001	1 < 2	240,64	0,01
3	-3973,91	8035,82	8237,91	8098,2	0,77	205,21	0.001	2 < 3	205,21	0,01

Bauer (2022) expresses that the most commonly used fit indices are the Bayesian Information Criterion (BIC), its sample-size-adjusted variant (SABIC), and the Akaike Information Criterion (AIC).

In the study, AIC, BIZ, SABIC, Entropy, LMR and BLRT values were used to decide the number of groups. The lowest values of AIC, BIC, SABIC and CAIC indicate better model fit (Ianculescu, Balog, Cristescu, Iordache & Bajenaru; 2019; Nylund, Asparouhov & Muthén; 2007; Pastor, Barron, Miller & Davis; 2007).

Figure 3

The density distribution (a) and scatter plot (b)

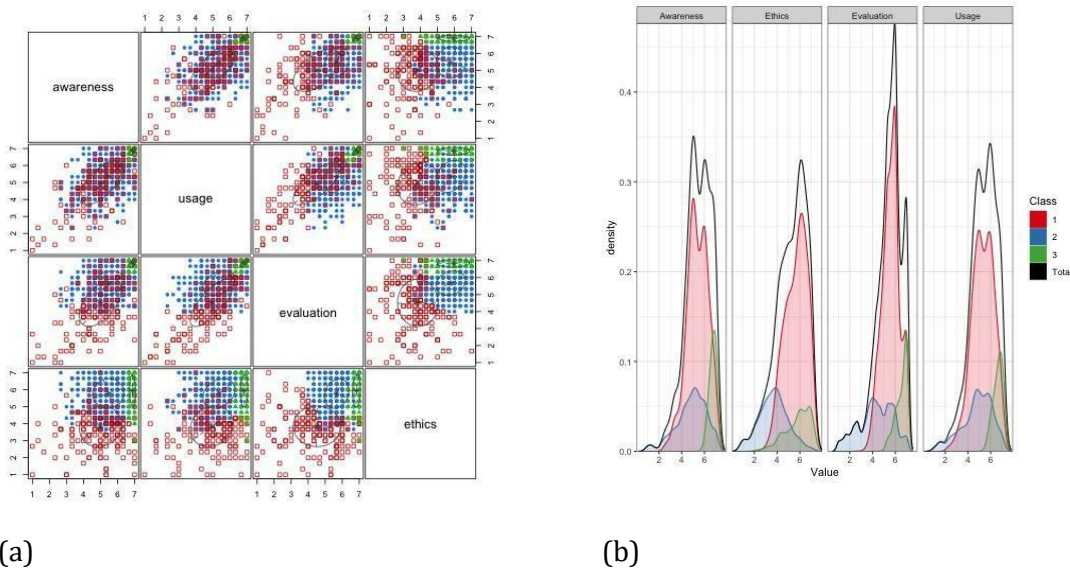

After the completion of the LPA analysis, the density distribution (a) and scatter plot (b) of the classes are displayed in Figure 3.

Figure 4*Classes and means*

Figure 3 displays the classes and their distributions as a result of LPA analysis. When Figure 3 is analyzed, the group with the highest average in all 4 indicators is determined as Class 3 and named as high on all aspects. The group with the lowest average in all 4 indicators was determined as Class 2 and named as "low on all aspects". The group with an average mean in all 4 indicators was determined as Class 1 and labeled as "moderate on all aspects".

4. Conclusion and Discussion

The pervasive integration of artificial intelligence across various aspects of life has underscored the importance of AI literacy. The scope of artificial intelligence literacy includes individuals' knowledge, usage, evaluation and ethical usage of artificial intelligence tools. When the literature is reviewed, it is explicit that there is no measurement tool in Turkish language for university students so as to designate the artificial intelligence literacy levels of individuals. Given the extensive application of artificial intelligence in all areas of life, enhancing AI literacy has become increasingly important. Consequently, the adapted version of this scale is anticipated to make a significant contribution to the academic literature. The objective of this study is to adapt the Artificial Intelligence Literacy Scale (AILS), originally developed by Wang et al. (2022), to assess the AI literacy levels of university students. As part of the adaptation process, the original authors were contacted via email, and permission was secured to translate the scale into Turkish. Then the scale adaptation procedures were started by obtaining ethics committee permission. In the sample distribution of the scale, a special care was given to ensure the necessary heterogeneity by collecting data from different departments. After the language translation and pre-pilot application for adaptation, the pilot study was conducted with 107 participants.

Considering the results, it was uncovered that the Cronbach Alpha value, calculated as the internal consistency coefficient of the study, was 0.81 and this result was consistent with the original scale of 0.83. In the literature, this value of 0.70 and above is accepted as appropriate for the scale to be reliable (Büyüköztürk, et al., 2013; DeVellis 2016). These values indicate that the scale is reliable.

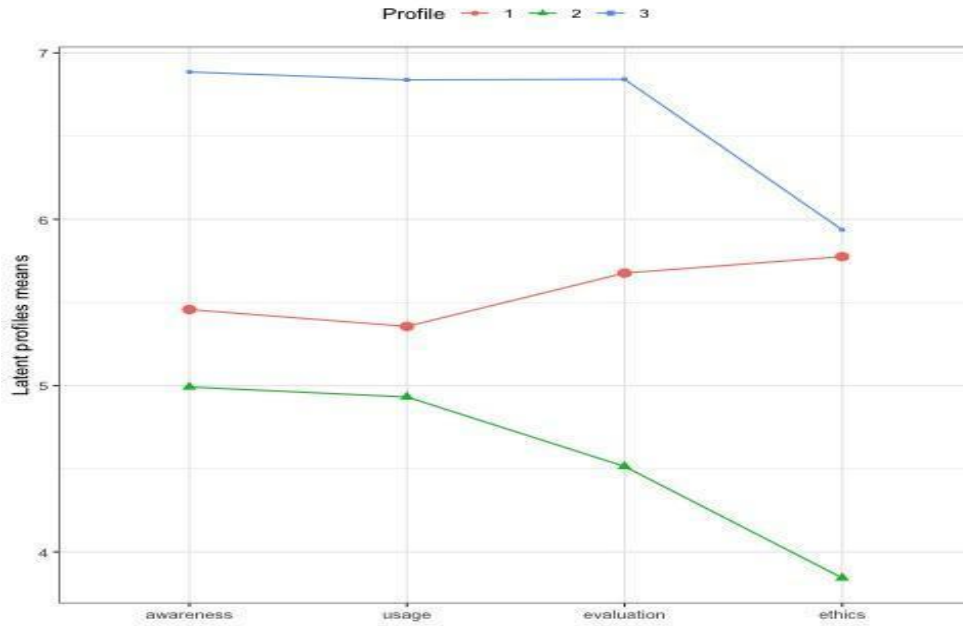
The various fit indices obtained from the adapted scale were as follows: RMSEA=.062, CFI=.949, AGFI=.933, GFI=.960, NFI=.949, TLI=.928, IFI=.916 (Hooper, et al., 2008; Schermelleh-Engel, et al., 2003).

Upon examining the correlation coefficients with the sub-dimensions of the scale, it was observed that they closely mirrored those of the original scale. While there is a high level of positive correlation with each sub-dimension of the scale, respectively: Awareness 0.75, Usage 0.80, Evaluation 0.81 and Ethics 0.66; in the original scale, a high positive relationship was found as follows: Awareness 0.78, Usage 0.72, Evaluation 0.72 and Ethics 0.68.

Latent profile analysis was performed using the Artificial Intelligence Literacy Scale adapted in the study. Three different profiles were observed in Figure 4. Each profile was expressed according to the average of four variables (awareness, usage, evaluation and ethics).

The findings of the study reveal that the participants in the profile designated as Profile 1 and shown with a red line consist of the individuals with medium level values in terms of awareness, usage, evaluation and ethics. These people may represent the individuals who have a generally positive attitude towards artificial intelligence technologies and their usage, and are aware of the potential negative effects of the technology. In a study conducted among graphic design students, it was determined that general attitudes towards AI were positive and this contributed to the creative processes of students (KUM, 2023).

The individuals indicated as Profile 2 in the research and indicated by the green line consist of the individuals with moderate values in terms of awareness and usage, but low values in terms of evaluation and ethics. This finding indicates that the aforementioned individuals understand what AI technologies are and how to use them, but they have deficiencies in evaluating the potential impacts of these technologies and especially in understanding their ethical aspects. These individuals may feel that the benefits of AI technologies outweigh the risks. For members of this profile, an advanced training program focusing on the ethical and evaluative dimensions of AI can be provided. Students' ethical concerns about AI applications are becoming more evident with the increasing use of these technologies in the field of health (Seçer, 2024). Providing transparency and explainability in the decision-making processes of AI is critical to increase users' trust in these systems (Canbay & Demircioğlu, 2021). Moreover, the ability of AI to mimic human intelligence requires in-depth thinking about the ethical responsibilities and consequences of these systems (Ece, 2024).

The group indicated as Profile 3 and shown with the blue line are the individuals with high values in terms of awareness, usage and evaluation but relatively low values in terms of ethics. This profile describes individuals who hold a positive view of AI technologies and their usage, yet remain cautious about the potential adverse impacts these technologies may have. These individuals are willing to take advantage of the benefits of AI technologies but are aware of the potential dangers.

AI can lead to a decrease in the quality of education as students become overly dependent on automated systems to complete their assignments, thus hindering their intellectual development (Katenova, 2024). The fear of losing one's job due to the capabilities of AI is common among students in various disciplines and many believe that AI can replace traditional educational roles and reduce the human element in teaching (AL-Tkhayneh et al., 2023).

The findings from the Latent Profile Analysis (LPA) indicate that there are significant variations in individuals' AI literacy levels. These differences are likely influenced by factors such as the length and type of individuals' interactions with AI technologies. Last but not least, these findings indicate that policies, research, practices or training to be developed within the scope of AI literacy should be designed for individuals with different profiles.

4.1 Limitations

A limitation of this study is that it does not include participants in the field of social sciences.

References

- Akogul, S., & Erisoglu, M. (2017). An approach for determining the number of clusters in a model-based cluster analysis. *Entropy*, 19(9), 452. <https://doi.org/10.3390/e19090452>
- Ali, S., Payne, B. H., Williams, R., Park, H. W., & Breazeal, C. (2019). Constructionism, ethics, and creativity: Developing primary and middle school artificial intelligence education. In *International workshop on education in artificial intelligence K-12 (EDUAI'19)* (pp. 1-4).
- AL-Tkhayneh, K., Alghazo, E., & Tahat, D. (2023). The advantages and disadvantages of using artificial intelligence in education. *Journal of Educational and Social Research*, 13(4), 105. <https://doi.org/10.36941/jesr-2023-0094>
- Anderson, J. C., & Gerbing, D. W. (1988). Structural equation modeling in practice: A review and recommended two-step approach. *Psychological Bulletin*, 103(3), 411-423. <https://doi.org/10.1037/0033-2909.103.3.411>
- Bauer, J. (2022). A primer to latent profile and latent class analysis. In *Methods for researching professional learning and development: Challenges, applications and empirical illustrations* (pp. 243-268). Cham: Springer International Publishing.
- Brendel, A. B., Mirbabaie, M., Lembcke, T. B., & Hofeditz, L. (2021). Ethical management of artificial intelligence. *Sustainability*, 13(4), 1-18. <https://doi.org/10.3390/su13041974>.
- Bruderer, H. (2016). The Birth of Artificial Intelligence: First Conference on Artificial Intelligence in Paris in 1951?. In: Tatnall, A., Leslie, C. (eds) *International Communities of Invention and Innovation. HC 2016. IFIP Advances in Information and Communication Technology*, vol 491. Springer, Cham. https://doi.org/10.1007/978-3-319-49463-0_12
- Bryman, A., & Cramer, D. (2001). *Quantitative data analysis with SPSS release 10 for Windows*. Routledge.
- Büyüköztürk, Ş. (2002). Faktör analizi: Temel kavramlar ve ölçek geliştirmede kullanımı [Factor analysis: Basic concepts and use in scale development]. *Kuram ve Uygulamada Eğitim Yönetimi*, 32(32), 470-483. Retrieved from <https://dergipark.org.tr/en/pub/kuey/issue/10365/126871>
- Büyüköztürk, Ş., Çakmak, E., Akgün, Ö., Karadeniz, Ş., & Demirel, F. (2013). *Bilimsel araştırma yöntemleri [Scientific research methods]*. Ankara: Pegem Akademi Yayınları.
- Canbay, P., & Demircioğlu, Z. (2021). Endüstri 5.0'a doğru: zeki otonom sistemlerde etik ve ahlaki sorumluluklar [Towards Industry 5.0: ethics and moral responsibilities in intelligent autonomous systems]. *Ajit-E Online Academic Journal of Information Technology*, 12(45), 106-123. <https://doi.org/10.5824/ajite.2021.02.006.x>
- Cole, D. A. (1987). Utility of confirmatory factor analysis in test validation research. *Journal of Consulting and Clinical Psychology*, 55, 1019-1031. <https://psycnet.apa.org/doi/10.1037/0022-006X.55.4.584>
- Danry, V., Leong, J., Pataranutaporn, P., Tandon, P., Liu, Y., Shilkrot, R., ... & Sra, M. (2022, April). AI-Generated Characters: putting Deepfakes to Good Use. In *CHI Conference on Human Factors in Computing Systems Extended Abstracts* (pp. 1-5). <https://doi.org/10.1145/3491101.3503736>
- Davenport, T., & Kalakota, R. (2019). The potential for artificial intelligence in healthcare. *Future Healthcare Journal*, 6(2), 94-98. <https://doi.org/10.7861/futurehosp.6-2-94>

- Defeng, Q., & Xiaojie, Q. (2020). Curriculum and teaching reform from the perspective of media history. *Philosophy Study*, 10(10). <https://doi.org/10.17265/2159-5313/2020.10.005>
- Drach, I., Petroye, O., Borodiyenko, O., Reheilo, I., Bazeliuk, O., Bazeliuk, N., & Slobodianiuk, O. (2023). The Use of Artificial Intelligence in Higher Education. *International Scientific Journal of Universities and Leadership*, 15, 66-82. <https://doi.org/10.31874/2520-6702-2023-15-66-82>
- Ece, N. (2024). Yapay zeka: denizcilik sektöründe kullanımı ve swot analizi [Artificial intelligence: its use in the maritime industry and swot analysis]. *Mersin Üniversitesi Denizcilik Ve Lojistik Araştırmaları Dergisi*, 6(1), 30-51. <https://doi.org/10.54410/denlojad.1491372>
- Fornell, C., & Larcker, D. F. (1981). Structural equation models with unobservable variables and measurement error: Algebra and statistics. *Journal of Marketing Research*, 18(3), 382-388. <https://doi.org/10.1177/002224378101800313>
- Ferikoğlu, D., & Akgün, E. (2022). An Investigation of Teachers' Artificial Intelligence Awareness: A Scale Development Study. *Malaysian Online Journal of Educational Technology*, 10(3), 215-231. <https://doi.org/10.52380/mojet.2022.10.3.407>
- Ferguson, S. L., Moore, E. W., & Hull, D. M. (2020). Finding latent groups in observed data: A primer on latent profile analysis in Mplus for applied researchers. *International Journal of Behavioral Development*, 44(5), 458-468. <https://doi.org/10.1177/0165025419881721>
- Garingan, D., & Pickard, A. (2021). Artificial intelligence in legal practice: exploring theoretical frameworks for algorithmic literacy in the legal information profession. *Legal Information Management*, 21(2), 97-117. <https://doi.org/10.1017/s1472669621000190>
- Hooper, D., Coughlan, J., & Mullen, M. (2008). Evaluating model fit: a synthesis of the structural equation modelling literature. In *7th European Conference on research methodology for business and management studies* (pp. 195-200).
- Hornberger, M., Bewersdorff, A., & Nerdel, C. (2023). What do university students know about Artificial Intelligence? Development and validation of an AI literacy test. *Computers and Education: Artificial Intelligence*, 5, 100165. <https://doi.org/10.1016/j.caeai.2023.100165>
- Hwang, H. S., Zhu, L. C., & Cui, Q. (2023). Development and Validation of a Digital Literacy Scale in the Artificial Intelligence Era for College Students. *KSII Transactions on Internet and Information Systems (TIIS)*, 17(8), 2241-2258. <https://doi.org/10.3837/tiis.2023.08.016>
- Ianculescu, M., Balog, A., Cristescu, I., Iordache, D. D., & Bajenaru, L. (2019). Latent profile analysis in health research: a case study. In *2019 22nd International Conference on Control Systems and Computer Science (CSCS)* (pp. 649-654). IEEE.
- Katenova, M. (2024). Artificial intelligence and business school students' performance. *International Journal of Religion*, 5(8), 96-101. <https://doi.org/10.61707/6wjvxp71>
- Khawlah, M., AL-Tkayneh, Hasan, A., Al-Tarawneh, Enas, Said, Ali, Abulibdeh, Moath, Alomery. (2023). Social and Legal Risks of Artificial Intelligence: An Analytical Study. *Academic Journal of Interdisciplinary Studies*, 12(3), 308. <https://doi.org/10.36941/ajis-2023-0079>
- Kline, R. B. (2005). *Principles and Practice of Structural Equation Modeling*. New York: The Guilford Press.
- Kong, S. C., Cheung, W. M. Y., & Zhang, G. (2021). Evaluation of an artificial intelligence literacy course for university students with diverse study backgrounds. *Computers and Education: Artificial Intelligence*, 2, 100026. <https://doi.org/10.1016/j.caeai.2021.100026>

- Laupichler, M. C., Aster, A., Haverkamp, N., & Raupach, T. (2023). Development of the "scale for the assessment of non-experts' AI literacy" –An exploratory factor analysis. *Computers in Human Behavior Reports*, 12, 100338.
- Law, N., Woo, D., de la Torre, J., & Wong, G. (2018). A global framework of reference on digital literacy skills for indicator 4.4.2. *UNESCO Institute for Statistics*. Retrieved from <https://unesdoc.unesco.org/ark:/48223/pf0000265403>
- Liu, N., Shapira, P., & Yue, X. (2021). Tracking developments in artificial intelligence research: constructing and applying a new search strategy. *Scientometrics*, 126(4), 3153-3192. <https://doi.org/10.1007/s11192-021-03868-4>
- McMillan, C. T. (2021). *Posthumanism in digital culture: Cyborgs, Gods and Fandom*. Emerald Publishing Limited.
- McMillan, J. H., & Schumacher, S. (2006). *Research in education: Evidence-based inquiry*. Pearson.
- Minbaleev, A. (2022). The concept of "artificial intelligence" in law. *Bulletin of Udmurt University Series Economics and Law*, 32(6), 1094-1099. <https://doi.org/10.35634/2412-9593-2022-32-6-1094-1099>
- Moloi, T., & Marwala, T. (2021). A High-Level Overview of Artificial Intelligence: Historical Overview and Emerging Developments. In *Artificial Intelligence and the Changing Nature of Corporations*. Springer, Cham. https://doi.org/10.1007/978-3-030-76313-8_2
- Munro, B. H. (2005). *Statistical methods for health care research*. Lippincott Williams & Wilkins.
- Muthén, B. O. (2001). Latent variable mixture modeling. In *New developments and techniques in structural equation modeling* (pp. 21-54). Psychology Press.
- Nylund, K. L., Asparouhov, T., & Muthén, B. O. (2007). Deciding on the number of classes in latent class analysis and growth mixture modeling: A Monte Carlo simulation study. *Structural Equation Modeling: A Multidisciplinary Journal*, 14(4), 535-569. <https://doi.org/10.1080/10705510701575396>
- Pastor, D. A., Barron, K. E., Miller, B. J., & Davis, S. L. (2007). A latent profile analysis of college students' achievement goal orientation. *Contemporary Educational Psychology*, 32(1), 8-47. <https://doi.org/10.1016/j.cedpsych.2006.10.003>
- Puspitaningsih, S., Irhadtanto, B., & Puspananda, D. (2022). The role of artificial intelligence in children's education for a digital future. *Kne Social Sciences, 5th International Conference on Education and Social Science Research (ICESRE)*, 642-647. <https://doi.org/10.18502/kss.v7i19.12483>
- Rosenberg, J. M., van Lissa, C. J., Beymer, P. N., Anderson, D. J., Schell, M. J., & Schmidt, J. A. (2019). *tidyLPA: Easily carry out latent profile analysis (LPA) using open-source or commercial software* [R package]. Retrieved from <https://data-edu.github.io/tidyLPA/>
- Ruiz-Real, J., Uribe-Toril, J., Arriaza, J., & Valenciano, J. (2020). A look at the past, present and future research trends of artificial intelligence in agriculture. *Agronomy*, 10(11), 1839. <https://doi.org/10.3390/agronomy10111839>
- Scrucca, L., Fraley, C., Murphy, T. B., & Raftery, A. E. (2023). *Model-based clustering, classification, and density estimation using mclust in R*. Chapman and Hall/CRC.
- Seçer, E. (2024). Technostress levels of physiotherapy and rehabilitation students, related factors and awareness of the use of artificial intelligence in health: a cross-sectional study. *Türkiye Klinikleri Journal of Health Sciences*, 9(1), 127-136. <https://doi.org/10.5336/healthsci.2023-100746>

- Seçer, İ. (2015). *Psikolojik test geliştirme ve uyarlama süreci: SPSS ve LISREL uygulamaları [Psychological test development and adaptation process: SPSS and LISREL applications]*. Anı Yayıncılık.
- Seong-Won Kim, Youngjun Lee. (2022). The artificial intelligence literacy scale for middle school students. *국컴퓨터정보학회논문지*, 27(3), 225-238. <https://doi.org/10.9708/jksci.2022.27.03.225>
- Schermelleh-Engel, K., Moosbrugger, H., & Müller, H. (2003). Evaluating the fit of structural equation models: Tests of significance and descriptive goodness-of-fit measures. *Methods of Psychological Research Online*, 8(2), 23-74. Retrieved from https://www.stats.ox.ac.uk/~snijders/mpr_Schermelleh.pdf
- Spurk, D., Hirschi, A., Wang, M., Valero, D., & Kauffeld, S. (2020). Latent profile analysis: A review and “how to” guide of its application within vocational behavior research. *Journal of Vocational Behavior*, 120, 103445. <https://doi.org/10.1016/j.jvb.2020.103445>
- Şimşek, Ö. F. (2007). *Yapısal eşitlik modellemesine giriş: temel ilkeler ve LISREL uygulamaları [Introduction to structural equation modeling: basic principles and LISREL applications.]*. Ekinoks.
- Tabachnick, B. G., & Fidell, L. S. (2007). *Using multivariate statistics*. Allyn & Bacon.
- Vermunt, J. K. (2022). Latent class analysis. In *International Encyclopedia of Education*, Fourth Edition. Oxford: Elsevier.
- Voulgari, I., Zammit, M., Stouraitis, E., Liapis, A., & Yannakakis, G. (2021, June). Learn to machine learn: designing a game based approach for teaching machine learning to primary and secondary education students. In *Proceedings of the 20th Annual ACM Interaction Design and Children Conference* (pp. 593-598). <https://doi.org/10.1145/3459990.3465176>
- Wang, B., Rau, P., & Yuan, T. (2023). Measuring user competence in using artificial intelligence: Validity and reliability of artificial intelligence literacy scale. *Behaviour & Information Technology*, 42(9), 1324-1337. <https://doi.org/10.1080/0144929x.2022.2072768>
- Wang, W., & Siau, K. (2019). Artificial intelligence, machine learning, automation, robotics, future of work and future of humanity: A review and research agenda. *Journal of Database Management*, 30(1), 61-79. <https://doi.org/10.4018/JDM.2019010104>
- Wardenaar, K. J. (2021). *Latent profile analysis in R: A tutorial and comparison to Mplus*. Retrieved from <https://psyarxiv.com/wzfttr/download>
- WHO (2015). *Process of translation and adaptation of instruments*. Retrieved from http://www.who.int/substance_abuse/research_tools/translation/en/
- Williams, R., Park, H., Oh, L., & Breazeal, C. (2019). Popbots: designing an artificial intelligence curriculum for early childhood education. *Proceedings of the AAAI Conference on Artificial Intelligence*, 33(01), 9729-9736. <https://doi.org/10.1609/aaai.v33i01.33019729>
- Xu, F. (2023). The link between artificial intelligence and computer technology. *Sixth International Conference on Intelligent Computing, Communication, and Devices (ICCD 2023)*. <https://doi.org/10.1117/12.2683091>
- Yin, R. K., & Moore, G. B. (1987). The use of advanced technologies in special education: Prospects from robotics, artificial intelligence, and computer simulation. *Journal of Learning Disabilities*, 20(1), 60-63. <https://doi.org/10.1177/002221948702000111>
- Yeşilyurt, S., & Çapraz, C. (2018). Ölçek geliştirme çalışmalarında kullanılan kapsam geçerliği için bir yol haritası [A roadmap for content validity used in scale development studies]. *Erzincan Üniversitesi Eğitim Fakültesi Dergisi*, 20(1), 251-264. <https://doi.org/10.17556/erziefd.297741>

Article Information Form

Author Notes: The author would like to express their sincere thanks to the editor and the anonymous reviewers for their helpful comments and suggestions.

Author Contributions: All authors contributed equally to the study.

Conflict of Interest Disclosure: No potential conflict of interest was declared by the author.

Copyright Statement: Authors own the copyright of their work published in the journal and their work is published under the CC BY-NC 4.0 license.

Supporting/Supporting Organizations: No grants were received from any public, private or non-profit organizations for this research.

Ethical Approval and Participant Consent: Ethics committee permission for this study was obtained from Sakarya University of Applied Sciences Ethics Committee of Rectorate with the decision dated 11.12.2023 and numbered 39.

Plagiarism Statement: This article has been scanned by iThenticate.

Appendix

Yapay Zekâ Okuryazarlığı Ölçeği

No		Kesinlikle Katılmıyorum ①	Katılmıyorum ②	Kısmen Katılmıyorum ③	Kararsızım ④	Kısmen Katılıyorum ⑤	Katılıyorum ⑥	Kesinlikle Katılıyorum ⑦
1.	Akıllı cihazlar ile akıllı olmayan cihazlar arasında ayırım yapabilirim.	①	②	③	④	⑤	⑥	⑦
2.	Yapay zekâ teknolojisinin bana nasıl yardımcı olabileceğini bilmiyorum.	①	②	③	④	⑤	⑥	⑦
3.	Kullandığım uygulama ve ürünlerde yapay zekâ teknolojinin olup olmadığını tespit edebilirim.	①	②	③	④	⑤	⑥	⑦
4.	Günlük işlerimde bana yardımcı olması için yapay zekâ uygulamalarını veya ürünlerini başarıyla kullanabilirim.	①	②	③	④	⑤	⑥	⑦
5.	Yeni bir yapay zekâ uygulamasını veya ürününü kullanmayı öğrenmek benim için genellikle zordur.	①	②	③	④	⑤	⑥	⑦
6.	İş verimliliğimi artırmak için yapay zekâ uygulamalarını veya ürünlerini kullanabilirim.	①	②	③	④	⑤	⑥	⑦
7.	Bir süre kullandıktan sonra bir yapay zekâ uygulamasının veya ürününün yeteneklerini ve sınırlamalarını değerlendirebilirim.	①	②	③	④	⑤	⑥	⑦
8.	Akıllı asistan* tarafından sağlanan çeşitli çözümler arasından uygun bir çözüm seçebilirim.	①	②	③	④	⑤	⑥	⑦
9.	Belirli bir görev için çeşitli yapay zekâ uygulamaları veya ürünleri arasından en uygun olanı seçebilirim.	①	②	③	④	⑤	⑥	⑦
10.	Yapay zekâ uygulamalarını veya ürünlerini kullanırken her zaman etik ilkelere uyarım.	①	②	③	④	⑤	⑥	⑦
11.	Yapay zekâ uygulamalarını veya ürünlerini kullanırken gizlilik ve bilgi güvenliği konularına asla dikkat etmem.	①	②	③	④	⑤	⑥	⑦
12.	Yapay zekâ teknolojisinin kötüye kullanımına karşı her zaman dikkatliyimdir.	①	②	③	④	⑤	⑥	⑦

Dipnot: Akıllı asistan*, ses komutlarını anlayan ve komutlar kapsamında ilgili görevleri yerine getiren uygulamalardır.