

## Araştırma Makalesi / Research Article

### Development and Application of A Wearable Technology Product That Detects and Informs The Presence of Electrical Energy

Burak BOĞAZKESENLİ<sup>1</sup>, Aytaç Uğur YERDEN<sup>2\*</sup>

<sup>1</sup> İstanbul Gedik Üniversitesi, Lisansüstü Eğitim Enstitüsü, İş Sağlığı ve Güvenliği Ana Bilim Dalı, Tezli Yüksek Lisans Öğrencisi, İstanbul, Türkiye,

ORCID ID: <https://orcid.org/0009-0000-6143-1080>, bb.burak@hotmail.com

<sup>2\*</sup> İstanbul Gedik Üniversitesi, Mühendislik Fakültesi, Endüstri Mühendisliği Bölümü, İstanbul, Türkiye,

ORCID ID: <https://orcid.org/0000-0002-3886-802X>, aytac.yerden@gedik.edu.tr

Geliş/ Received: 06.06.2024;

Revize/Revised: 21.08.2024

Kabul / Accepted: 26.08.2024

**ABSTRACT:** Electrical energy has both positive and negative effects nowadays, with the potential to cause property and human loss. Technical professionals working at electrical energy generation, distribution, and utilization points may die due to carelessness or neglect. Although there are protection elements (fuses, residual current protection relays, etc.) in electrical panels that interrupt the flow of electrical energy in the event of a shock, there may be working areas where energy cannot be cut off due to incorrect electrical connections caused by unauthorized people interacting with the panel. Existing protective components may be insufficient. The experiments include both wired protection elements and wireless detection elements. However, they need to be enhanced because they have limited detection distances. Furthermore, using an ergonomic design can improve operability. New protection and warning features must be designed using developing technology. To prevent employees from being shocked by being exposed to electrical energy in the workplace, AC voltage can be detected without contact using this study, which includes the design and test results of a wearable technology product that warns when electricity is present. An electrical circuit that technical staff can wear on their finger detects voltage without contact and displays the existence of energy with a red LED. It was discovered that the test circuit detects 230V AC electrical energy up to 8 cm away and warns with light.

**Keywords:** Non-Contact voltage detection, Wearable technology, Voltage detector, Non-Contact Voltage Detector.

\*Sorumlu yazar / Corresponding author: aytac.yerden@gedik.edu.tr

Bu makaleye atıf yapmak için /To cite this article

Boğazkesenli, B., Yerden, A. U. (2024). Development and Application of A Wearable Technology Product That Detects and Informs The Presence of Electrical Energy. Journal of Materials and Mechatronics: A (JournalMM), 5(2), 228-249.

## 1. INTRODUCTION

Technologies for producing and distributing energy have advanced quickly since the discovery of electrical energy. The areas of use of electrical energy have expanded and become indispensable for life. Some of the main reasons for this development are the easy production and distribution of electrical energy and the proliferation of devices that use this energy over the years. Electrical energy is a type of energy that can be produced quickly, transmitted quickly, and used stably. Today, many energy sources can be converted into electrical energy. Thanks to these features, it is the most popular and widely used type of energy. However, it is not without its dangers. It even has effects that can be fatal if not taken care of. Of course, the critical point here is "if not careful". In the study (Ceylan, 2012), it is stated that approximately 7% of the personnel working at TEİAŞ are regularly trained in Occupational Health and Safety (OHS) every year, and it is thought-provoking that approximately 69% of the employees are exposed to accidents had received OHS training before. No matter how trained the technical personnel are, carelessness and similar reasons can always cause accidents with negative consequences. There is a threat at every point where electrical energy is generated, distributed, and converted into work and used with various devices. Electrical energy, an energy source that can cause loss of life and property as a result of poor workmanship and carelessness, is a resource that needs to be used with care and caution and be efficient and valuable.

Electrical science tells us to follow "Occupational Health and Safety" regulations despite all these dangerous features. For this reason, we must produce, distribute, and use this indispensable energy source by the established rules. Every person must comply with these rules at every point where electrical energy exists so that the measures taken will work. However, there may be direct exposure to electrical energy due to ignorance, poor workmanship, and carelessness. There can be a wide variety of reasons here. For example, in cases such as an employee working in the electrical panel where he works as a result of fatigue without cutting the energy or the energy of the panel is turned on by another employee without the knowledge of the technician working in the electrical panel, life and property damages and even loss of life may occur. In such cases, although there are protection elements in the panels and devices, there may be situations where they cannot prevent loss of life and property. Among these protection elements, the "Residual Current Protection Relay", which protects living beings, may not be used in many facilities, production sites, offices or residential units even today, when technology is developing. Alternatively, with the view that it will take a very short time, an electrical fault can be eliminated by working under energy.

Protection elements directly connected to the system with the cable are widely used worldwide to protect against the harmful effects of electrical energy. These systems include elements that open the line in case of shock, short circuit, etc. However, this form of protection may not be able to protect against damages that may occur due to non-standard equipment installations by unauthorized persons other than the elements connected to the electrical system by cable. Wireless remote monitoring systems are used in electricity generation and distribution points today. Instant data of the entire system can be obtained from the control center. However, there is no monitoring in places such as factories, homes, and schools where the end user is located. This situation brings many non-standard electricity usages. Centralized remote monitoring of the end user's electricity system is also costly. Therefore, there is a need for new protection equipment that can prevent the harmful effects of electrical energy from harming living things in many cases.

The main reason for this study is that employees are not exposed to working under electricity for various reasons (troubleshooting, etc.); if there is electrical energy in the area where they work (for example, an electrical distribution panel) and they are not aware of it, it is to make an efficient

design for a wearable technology product that instantly notifies the employee of the presence of this electricity. The most efficient electronic circuit design and ergonomics were analyzed for the design to make it a wearable technology product.

## 2. LITERATURE REVIEW

The Tosun (2022) states that the causes of electrical accidents can be listed as accidents caused by insulation defects, accidents caused by electrical leakage and electrical charging of the metal parts of the devices, accidents that may occur as a result of contact with energy transmission channels, accidents occurring on or near power poles, accidents caused by work performed near live areas, hazards caused by explosions and accidents caused by short circuits in power lines. It is also stated that the source of this problem for our country is generally due to insulation failure and irregular controls (Tosun, 2022). According to the study (Mutlu & Cabuk, 2021), although there are many different causes of occupational accidents, 80% of them are caused by the defects of the employees. (Ates et al., 2019) stated that the most important method of protection from occupational accidents caused by electrical energy is to prevent them before they occur. Karadeniz (2012) reported that occupational health and safety inspections and legislation are inadequate in Asian countries, especially China and India (Karadeniz, 2012). The most common cause of accidents is electrical leakage in machinery and devices. Accidents caused by insulation faults follow this. In the electricity distribution sectors in Turkey, the most common accidents caused by electricity are people's exposure to active electric currents, falls from heights, cave-ins during underground cable work, and fires and arc explosions. For such reasons, new protection elements or measures are implemented with the developing technology. The rapid development of technology is becoming one of the most essential tools of sustainability (Karabiyik Yerden, 2023). Every measure or technology put into practice gains functionality with employees' awareness. However, if technological, occupational health, safety measures, and employee awareness are used together, this highly efficient energy source can be used healthily.

The ergonomic functionality of a wireless technology that senses and reports the presence of electrical energy is as necessary as its construction. Today, there is a wide range of research on wearable technologies. Pamuk and Yildiz (2021) reported that electrically conductive textile products are used in fields such as industry, space, military, protection, defense, and health (Pamuk & Yildiz, 2021). Wearable tissue technology products placed on and under the skin and their use, especially in health-related areas, were mentioned (Turkcan, 2021).

With the development of technology, there have been new studies on wireless voltage sensing. For example, a control pen can wirelessly indicate the presence of electrical energy in a conductor or metal surface over short distances. However, there are also disadvantages, such as short distances and ergonomic non-functionality. Since it only provides control when the device is operated, it has no continuity. It cannot perform instant monitoring.

Wireless voltage-sensing wearable technology products can also perform instantaneous monitoring. For example, the design shown below is designed as a wristband, making it ergonomically functional. In the study conducted at the University of Miami, detection was made using capacitive principles. It is designed for 120V voltage detection. There is a certain detection distance. The study states that it can make erroneous detection.

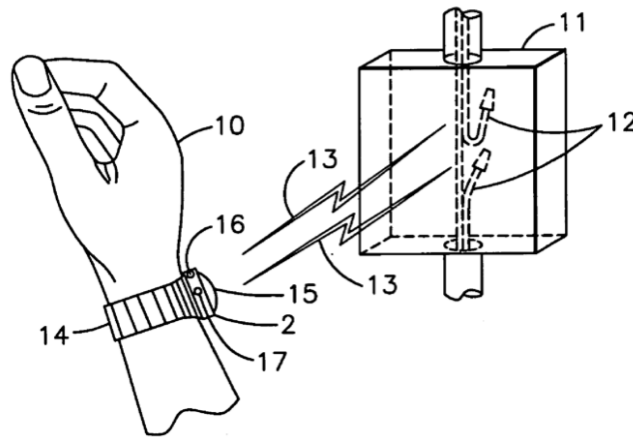

**Figure 1.** Patent for a wrist-wearable voltage detector (Crockett)

Some studies can perform remote wireless voltage sensing in high-voltage systems. The block diagram of a design designed with micromechanical systems (MEMS) technology that can detect the presence of energy in the conductor at a distance of 2 meters is given below. The wireless analog signal received from the sensor is converted into a digital signal and processed. It can be monitored with the alarm circuit and communication module.

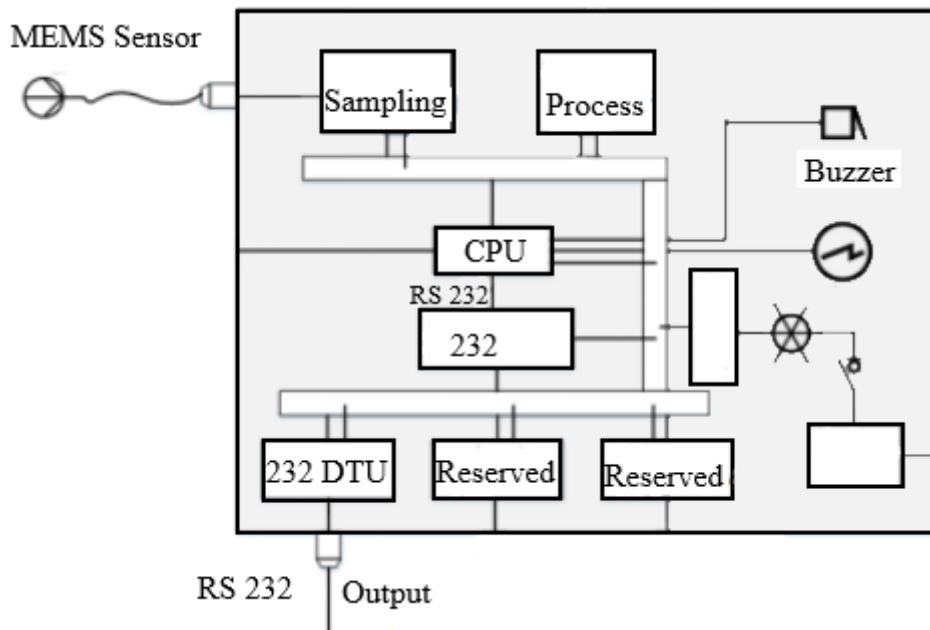

**Figure 2.** Block diagram of a contactless voltage detector (Zhu et al., 2018)

Some designs wirelessly report the presence and level of voltage. The image below shows a design that can wirelessly measure the amplitude of the voltage on transmission lines and works with electric field sensing.

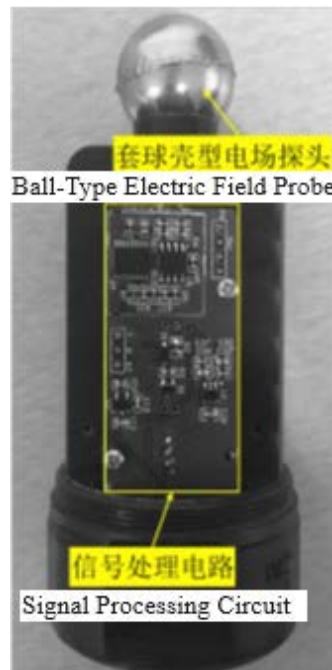

**Figure 3.** Electrical tester prototype (Yang et al., 2021)

Similar studies are also available. However, few studies are ergonomically available to technical personnel.

Wearable smart devices defined as; "Wearable technology", "wearable device" and "wearables" are all electronic or computer technologies that represent accessories and clothing that can be worn comfortably on the body" (Sagbas et al., 2016). As we can understand from the definition of wearable technologies, we can consider the essential design elements for these electronic-based devices under three main headings.

- Energy source
- Electronic-based functionality
- Comfort in the body (Ergonomics)

The battery is one of this work's most critical design parts and must be produced in small sizes. If a non-ergonomic battery is used for the design, it becomes cumbersome and defeats its purpose. The battery is one of the most essential parts necessary for the design to work by providing the appropriate voltage for the circuit. There are many battery technologies from the past to the present. These battery technologies mainly work on generating electrical energy from chemical reactions. However, some systems generate electrical energy using different energy sources. In order to produce electrical energy generated by the movement of electrons in the atomic structures of objects, a wide variety of methods are used to provide this movement. There are many ways to store energy (Kozak & Kozak, 2012). Electrical energy storage is one of them. The most efficient energy storage system is electrical energy storage with superconducting magnetic energy storage with an efficiency of 0.97. However, this method does not seem suitable for battery technology, which is also essential for its economic use in daily life. Rechargeable batteries under the following headings examined: Lead Acid Batteries, Nickel Cadmium Batteries, Nickel Zinc Batteries, Nickel-Metal Hydride Batteries, Lithium Ion Batteries, Lithium-Sulfur Batteries, Sodium-Ion Batteries, and Metal-Air Batteries. These batteries can be charged for continuous use. They are based on chemical reactions. Lithium-ion batteries seem the most promising for future development (Sezer et al., 2022). However, aside from the extensive use of chemical-based batteries in the market, there is a wide range of renewable and

promising battery and power generation technologies based on various principles. They are both miniaturizable and renewable energy, which may mean we will soon use them widely instead of chemical-based batteries.

Thermoelectric generators (TEJ) generate electricity from body heat. This technology uses the temperature difference between skin heat and air to generate energy. It is a technology that can be used in this study as it is sustainable and can be produced in small sizes. Thermoelectric modules work with the Seebeck effect (Mamur, 2013). According to the 2nd Law of Thermodynamics, heat moves from the hot surface to the cold surface. In this way, DC voltage will occur at the TEJ terminals.

One of the studies carried out in recent years is to generate electrical energy using moisture in the air. Since moisture is everywhere, this method can be used for many systems without the problem of finding resources. Electrical energy can be generated with moisture in the air using protein nanoconductors (Liu et al., 2023). This system was named Air-Gen. This battery technology can be used in this study due to its small size and sustainability. The figure below shows the use of protein nanoconductors.

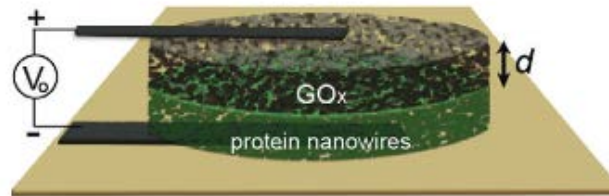

**Figure 4.** The use of protein nanoconductors as the basis of Air-Gen technology (Liu et al.,2023)

From a different perspective, supercapacitors are also shown as an energy source that can be used for wearable technology products. Li from the University of South Carolina produced a T-shirt that works like a supercapacitor (Korkmaz, 2018). He stated that a T-shirt from the store was immersed in fluoride solution and then produced at a high temperature in an oxygen-free environment. The surfaces of the clothing fibers turned into activated carbon, exhibiting supercapacitive behavior. He obtained a highly efficient solar cell with the paint he applied on flexible fabric (Eker, 2019). Such studies open the horizon for making flexible, ergonomic, and efficient energy sources for wearable technologies. One of the critical points in wearable technology products, such as the power supply, is the need for comfortable use on the body. Here, we come across the concept of ergonomics. Ergonomics is adapting the physical environment to human beings (Ertan & Eldem, 2022). Ergonomics can be created by working together with more than one discipline. At the beginning of these disciplines: engineering, physiology, anatomy, sociology, psychology, and architecture. In this study, the design was made as a ring to provide this feature. Today, athletes use wearable technologies with ring designs. Smart rings are designed to suit daily life with a sports-oriented perspective (Turgut et al., 2021). In this respect, we can conclude that the ring design is also suitable for this study. Because those who work with electrical energy, such as those who do sports activities, want to use their hands comfortably. In order to realize a design that is ergonomically small in size, the electronic circuit must also be small. While the size of a typical transistor was between 130 and 250 nanometers at the turn of the century, in 2016, a team of researchers at Lawrence Berkeley National Laboratory succeeded in making a 1-nanometer transistor using "carbon

nanotubes" and "molybdenum disulfide (MoS<sub>2</sub>)" and that this transistor was the smallest transistor ever made (Ersoz et al., 2018). Such studies play an essential role in realizing ergonomically favorable and small-sized designs as they reduce the size of electronic circuits.

### 3. MATERIALS AND METHODS

The progress of the work was as follows: First, the characteristics of the environment in which the non-contact voltage would be detected were examined. Then, a detection circuit was designed and tested based on these characteristics. The results of the prototyped work were shared according to the test results.

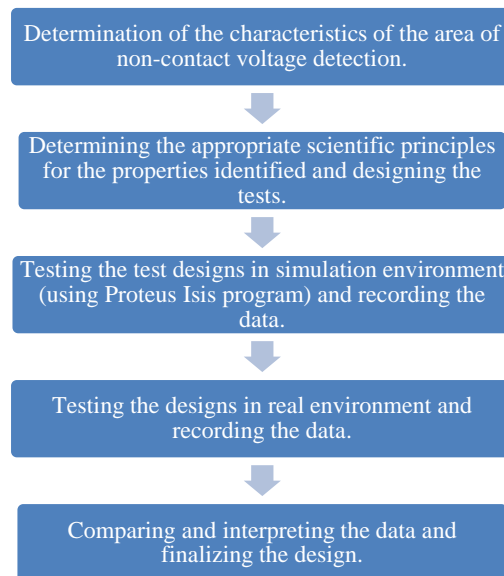

**Figure 5.** Progress of the study

When we look at the power line standards used in the world to reveal the characteristics of the environment to be measured for non-contact voltage sensor design, we see that various voltage and frequency values are adopted as standards in the networks in countries. In our country, the mains voltage is 230V, and the mains frequency is 50Hz. The voltage level varies to increase energy production and distribution efficiency. High voltage levels of 66kV, 154kV, 380kV, and medium voltage levels of 6.3kV, 15kV, and 33kV are used in the distribution of electrical energy. In end-user distribution panels, 400V and 230V are used. Since technical workers mainly encounter 220V and 380V in distribution panels, these will be the measurement values on which we will base our design. In addition, our primary frequency of 50 Hz is the other variable we will base on. The scientific calculations used in the study are essential for selecting electronic circuit elements for circuit design. Ambient AC voltage for operation: Since the frequency is 50 Hz, it should be designed to be sensitive to this frequency. However, since the operation will perform contactless detection, the circuit will receive this signal with the help of an antenna. At this point, it is necessary to design an antenna. Among omnidirectional antennas, the monopole antenna can be used for energy detection because the direction of the signal to be detected may not be the only one. This antenna design can detect omnidirectional signals. However, when the antenna length is calculated for the frequency under study,

$$\lambda = \frac{c}{f} = \frac{300\,000}{50} = 6\,000\text{ mt} \quad (1)$$

$$\lambda \times 0.95 = 5\,700\text{ mt} \quad (2)$$

$$\text{Antenna length} = 5\,700 / 4 = 1\,425\text{ meters} \quad (3)$$

f : Transporter frequency

c : Speed of light  $\approx 3 \times 10^8$  m/s

$\lambda$  : Carrier wavelength (carrier wavelength:  $\lambda=c/f$ )

This is unlikely for a small wearable technology product. Therefore, the antenna input signal will be calculated according to the capacitive effect in the antenna design. For the capacitive effect, the point with electrical energy can be considered as the capacitor conductor plate, the antenna of the testing circuit as the other plate, and the air in between as the insulator material. When the antenna of the non-contact voltage detector approaches the conductor, a capacitance is formed between them, and we can find the amplitude of the current in the antenna using the following calculation.

One turn around the coil;

$$a = 2\pi r = 2 \times \pi \times 0.05 = 0.0314 \quad (4)$$

Surface area;

$$A = \text{Number of coil rounds} \times a = 15 \times 0.0314 = 0.471\text{ m}^2 \quad (5)$$

Capacity calculation (for a distance of 4 cm);

$$C = \frac{A \times \epsilon_0}{d} = \frac{0.471 \times 8.85 \times 10^{-12}}{0.04} = 0.1042\text{ nF} \quad (6)$$

Capacitive reactance;

$$X_c = \frac{1}{2\pi f C} = \frac{1}{2\pi \times 50 \times 0.1042 \times 10^{-9}} = 30.5479 \times 10^6\ \Omega \quad (7)$$

Current to be generated in the coil (for 230V);

$$I_c = \frac{V}{X_c} = \frac{230}{30.5479 \times 10^6} = 7.5291\ \mu\text{A} \quad (8)$$

This calculated current value is the current value that will occur when the antenna with 15 turns and 1 cm diameter is 3 cm close to a 230V conductor. Also, for this current value to occur, the magnetic field strength in the conductor;

$$B = \mu_0 \frac{N \times I}{L} = \frac{4\pi \times 10^{-7} \times 7.5291 \times 10^6}{0.02} = 7.09601 \times 10^{-9}\text{ T} \quad (9)$$

a = Perimeter area of a single turn

A = Surface area



C =	Capacity
E0 =	Electric constant
d =	Distance between plates
Xc =	Capacitive reactance
f =	Frequency
V =	Voltage
I =	Current
$\mu_0$ =	Magnetic constant
N =	Number of turns (Number of rounds)
L =	Length of the coil (antenna)

If this calculated current value is applied to similar network voltage values in our country, the values in the table below are calculated.

**Table 1.** Current and required magnetic field values calculated according to voltage level

Voltage (V) AC	Current ( $\mu\text{A}$ )	Magnetic Field (T)
230	7.5291	$7.09601 \times 10^{-9}$
400	13.09	$1.2337 \times 10^{-8}$
480	15.71	$1.48063 \times 10^{-8}$
600	19.64	$1.85103 \times 10^{-8}$

The antenna shape to be used will be in the form of a solenoid coil. A spiral shape will also be used to increase the current in the antenna. The small current value generated in the antenna will be amplified in the transistors connected to the Darlington. It will be large enough to feed the warning elements such as LED, Buzzer. Circuits with two and three transistors were tested. In the circuit, several different transistor models were tested to increase the current in the antenna, and the efficient model was preferred. The block diagram of the designed circuit is as follows (Figure 6). As can be seen from the schematic, the signal from the antenna stage is amplified at the Darlington transistor stage and transmitted to the output stage. The LED at the output stage illuminates with sufficient antenna input signal to indicate the presence of electrical energy.

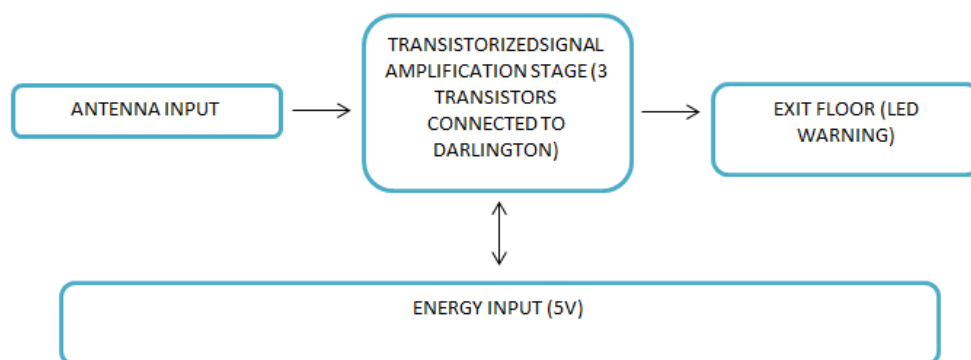

**Figure 6.** Block diagram of the circuit

When the transistors are connected in Darlington, the total current gain can be written as the product of the current gains of the individual transistors. For two transistors, when the transistor models used are the same beta kare, and for three transistors,  $\beta^3$  can be written as.

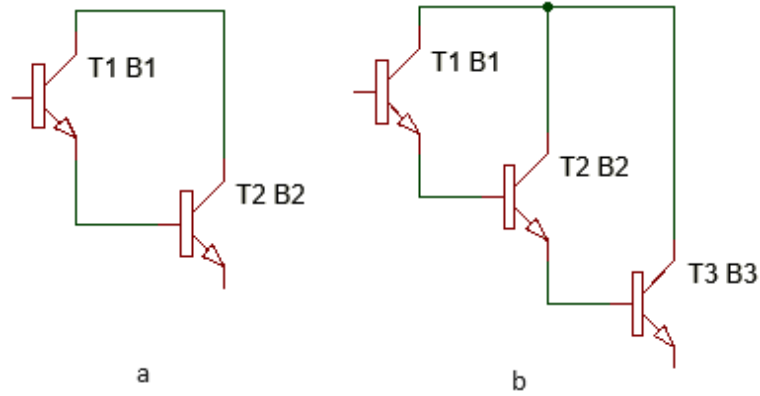

**Figure 7.** a) Two transistor darlington connection  $\beta^2$ , b) Three transistor darlington connection  $\beta^3$

In the test circuit where two transistors are connected to Darlington, a detection test will be performed at the point where 220V voltage is present using "2N3004" and "BC547" transistors and a 15-turn wound antenna. The detection range will be found by changing the distance of the antenna to the conductor. The first test circuit is given in Figure 8.

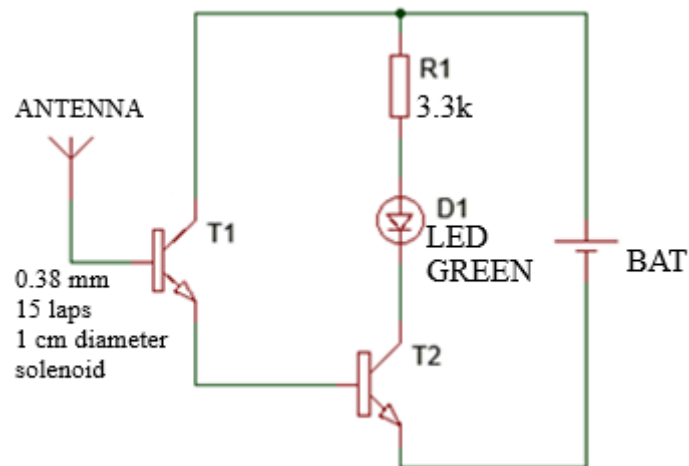

**Figure 8.** Test circuit for two transistor darlington connection (test circuit 1)

The second test circuit uses "2N3904" and "BC547" transistors with three transistor Darlington connections. The tests will be performed with the conductor carrying energy at a 230V voltage level. A 15-turn wound solenoid coil is used as an antenna. The second test circuit is given in Figure 9.

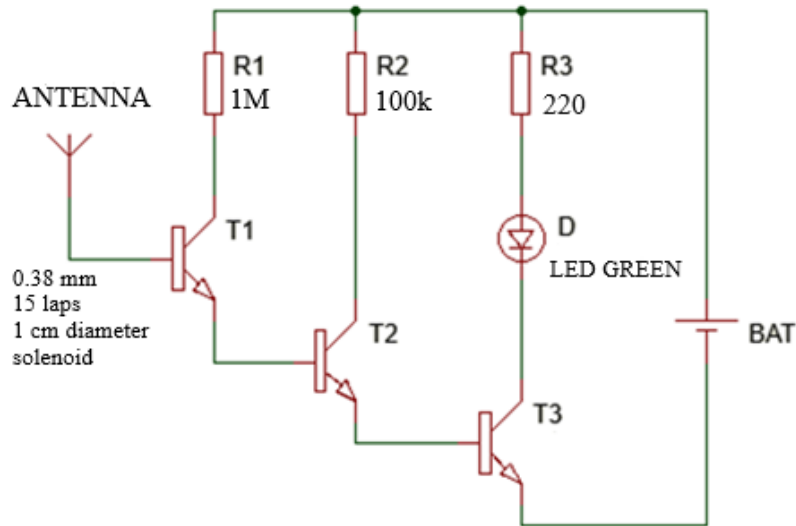

**Figure 9.** Test circuit for three transistor darlington connection (test circuit 2)

In both test circuits, the flattened antenna and the solenoid coil antenna will be tested. The characteristics of the selected transistors are close to each other. When we look at the information page of both transistors,  $\beta$  current gains according to the "Base" current calculated above is given as 100 on average. According to this, the total average current gain in a two-transistor Darlington connection;

$$\beta^2 = 100 \times 100 = 10000$$

And the total average current gain in a three-transistor Darlington connection;

$$\beta^3 = 100 \times 100 \times 100 \times 100 = 1000000.$$

The operation of the test circuits is shown in the flowchart in Figure 10.

According to the detection results of the test circuits in the simulation environment, the efficient circuit design will be used in the real environment test. The data obtained from the simulation are given in Table 2 and Table 3.

The designed circuits were tested in the simulation environment (Proteus Isis) at the calculated antenna current level and upper and lower values, and the output currents were measured. The LEDs connected to the output transistors were observed, and the data was recorded in Tables 2 and 3.

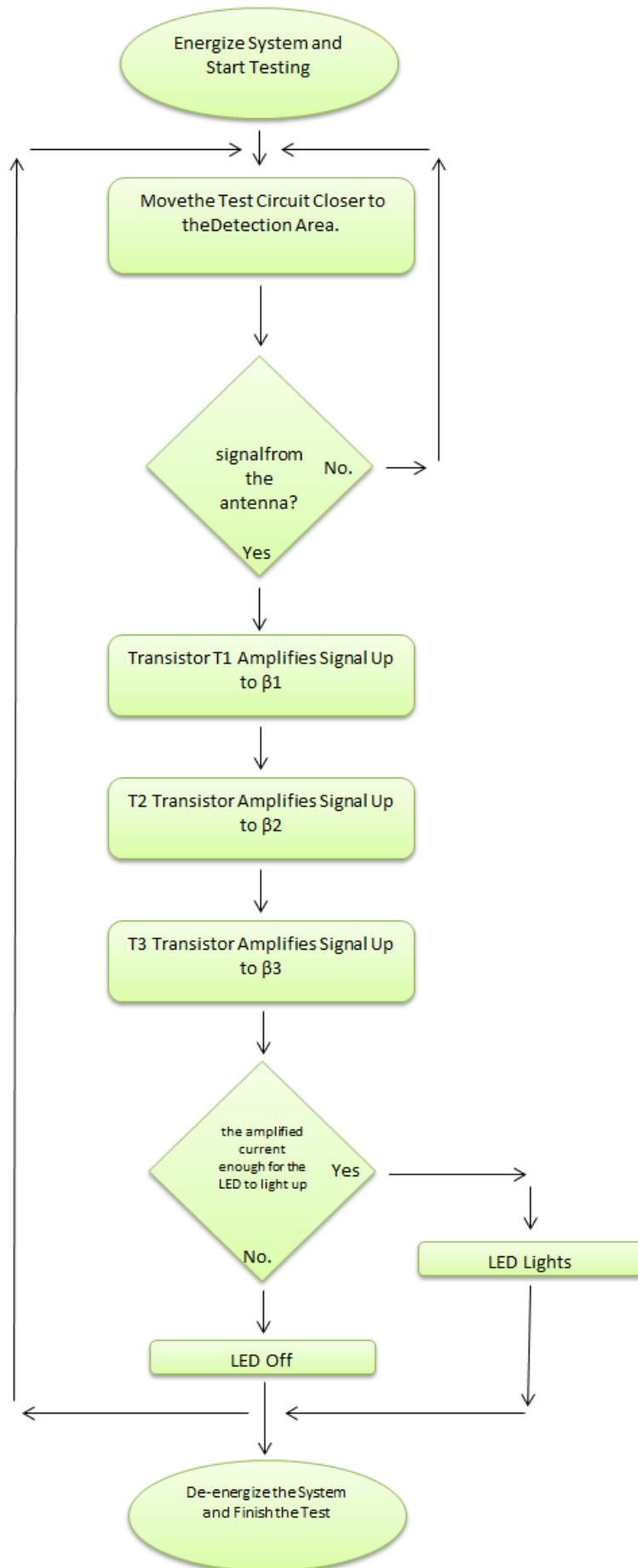

Figure 10. Flow diagram of the test circuit operation algorithm

**Table 2.** Measurements with test circuit 1

<b>Test Circuit 1</b>				
<b>Supply</b>	<b>2N3904</b>		<b>BC547</b>	
<b>Voltage 5V</b>	Output	LED	Output	LED Status
	Current	Status	Current	
	(mA)		(mA)	
<b>Ib1</b>	0.84	FIRE	0.84	FIRE ON FIRE
<b>Antenna</b>		ON		
<b>Current</b>		FIRE		
<b>(5<math>\mu</math>A)</b>				
<b>Ib1</b>	0.85	FIRE	0.85	FIRE ON FIRE
<b>Antenna</b>		ON		
<b>Current</b>		FIRE		
<b>(7.5291<math>\mu</math>A)</b>				
<b>Ib1</b>	0.85	FIRE	0.85	FIRE ON FIRE
<b>Antenna</b>		ON		
<b>Current</b>		FIRE		
<b>(10<math>\mu</math>A)</b>				
<b>Ib1</b>	0.85	FIRE	0.85	FIRE ON FIRE
<b>Antenna</b>		ON		
<b>Current</b>		FIRE		
<b>(15<math>\mu</math>A)</b>				
<b>Ib1</b>	0.85	FIRE	0.85	FIRE ON FIRE
<b>Antenna</b>		ON		
<b>Current</b>		FIRE		
<b>(20<math>\mu</math>A)</b>				

According to the measurements made in the simulation environment, the second test circuit with three Darlington-connected transistors has a higher current gain than the Darlington-connected circuit with two transistors. Therefore, the LED connected to the "Collector" end of the transistor T3 lights up more strongly. This shows us that test circuit 2 works more efficiently. Real-earth experiments will proceed through this circuit.

Since the transistor models are close to each other, they gave similar results. Of the two transistors, 2N3904 was chosen for the test.

Test circuit 2 will be used for a real-world test. For the test, the test circuit will be brought closer to the conductor line energized at a 230V voltage level at certain distances, and the detection limits of the circuit will be determined. In addition, the operating efficiency of the circuit will be measured in terms of the distance between a solenoid antenna and a spiral antenna.

**Table 3.** Measurements with test circuit 2

Supply Voltage 5V	Test Circuit 2			
	2N3904		BC547	
	Output Current (mA)	LED Status	Output Current (mA)	LED Status
<b>Ib1 Antenna Current (5<math>\mu</math>A)</b>	10.2	BURNED	10.2	BURNED
<b>Ib1 Antenna Current (7.5291<math>\mu</math>A)</b>	10.3	BURNED	10.3	BURNED
<b>Ib1 Antenna Current (10<math>\mu</math>A)</b>	10.4	BURNED	10.4	BURNED
<b>Ib1 Antenna Current (15<math>\mu</math>A)</b>	10.5	BURNED	10.5	BURNED
<b>Ib1 Antenna Current (20<math>\mu</math>A)</b>	10.5	BURNED	10.5	BURNED

The test circuit was installed on a breadboard, and 15 turns of wound solenoid coil were used as an antenna.

The flow diagram of the sequence to be applied for the test is as follows.

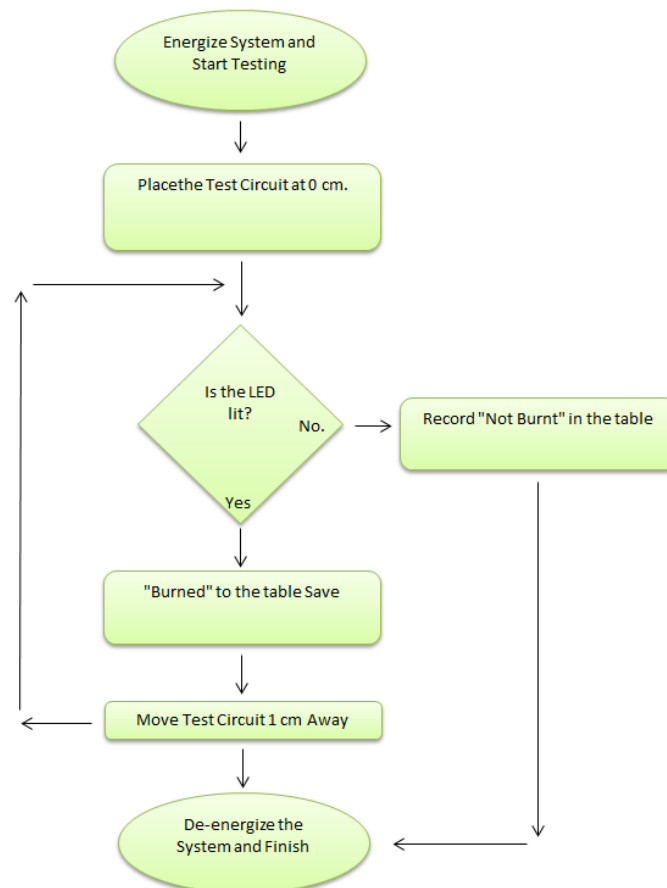
**Figure 11.** Flow diagram to be applied for testing

According to the flow diagram, the test circuit, which will be removed from the conductor passing electrical energy with a precision of 1 cm, will be tested with LED until it does not react. The results are shared in Table 4. During the test, the stable operation of the circuit will also be observed and recorded in the table.

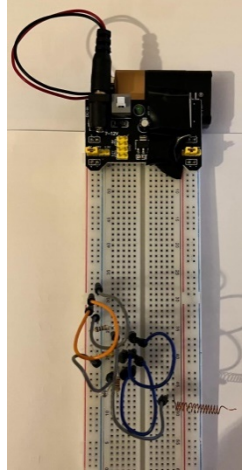

**Figure 12.** Test circuit (solenoid antenna)

Figure 12 shows the test circuit installed on the breadboard. The circuit made using "2N3904," selected as a transistor, is at the bottom of the breadboard. On the top side, a source is connected to energize the circuit.

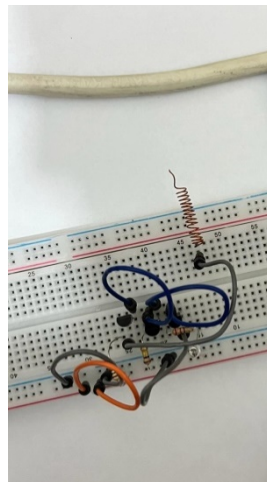

**Figure 13.** Test setup

Figure 13 shows the circuit's test setup. A meter measures the distance of the antenna to the conductor passing electrical energy.

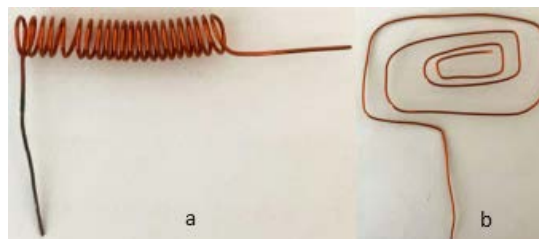

**Figure 14.** a) Solenoid antenna, b) Spirid antenna

Figure 14 shows the antennas used during the test.

The test circuit was tested by positioning the solenoid coil antenna at specific distances from the conductor with 230V AC electrical energy with the help of a meter. The power was cut and checked to see whether it was affected by a source other than the current on the conductor. It was also tested using a spiral antenna. The test circuit was brought closer to the conductor, passing 230V AC energy at certain distances. The LED's burning and non-lighting status was observed, and the range in which it can be measured was determined. The data obtained are presented in Table 4. According to the measurement results of the test circuit, the tests with the solenoid coil antenna were more successful than the tests with the spiral antenna. It was able to detect the presence of voltage at a longer distance. According to the circuit test with a solenoid coil antenna, stable operation up to 8 cm was achieved.

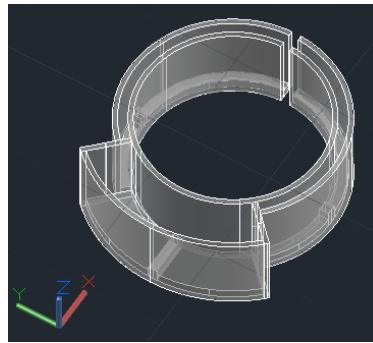

**Figure 15.** Ring-shaped wireless voltage sensing circuit design (Representative AutoCAD drawing)

Figure 15 shows a computer drawing of the design of this study. The drawing was drawn in the size of an average human finger. Thanks to the space left at the bottom of the ring shape, it has a design that can easily fit different finger sizes. The designed circuit will be placed in the ring shape printed from PLA material.

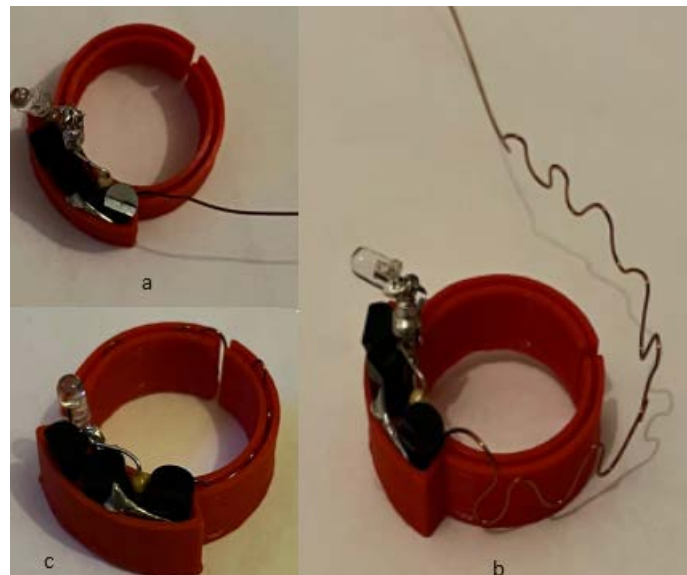

**Figure 16.** a) Placement of the sensing circuit in the design, b) Shaping the circuit antenna, c) Placement of the circuit antenna in the ring

As can be seen in the images given in Figure 16, the circuit that senses energy wirelessly was printed on a 3D printer in the shape of a ring. The area where the circuit is placed is at the top of the ring shape. The antenna for sensing was placed on the ring parts surrounding the finger.





**Figure 17.** Use of the design on the finger

Figure 17 shows a visual of the design in human hand. It shows that it is an ergonomic design thanks to its shape and dimensions that will not restrict hand and finger movements.

#### 4. RESULTS AND DISCUSSION

The detection status of the test circuit according to the distance is given in Table 4.

**Table 4.** Physical environment test results

Distance to Conductor (cm)	-Test Voltage AC 230V -Test Circuit Supply DC 5V	
	Solenoid Antenna	Spiral Antenna
	Detection Status of the Circuit According to the Lighting of the LED (Stable, Unstable, Very Unstable)	
1	Stable Operation	Stable Operation
2	Stable Operation	Stable Operation
3	Stable Operation	Worked Undecided
4	Stable Operation	X-No Detection
5	Stable Operation	X-No Detection
6	Stable Operation	X-No Detection
7	Stable Operation	X-No Detection
8	Stable Operation	X-No Detection
9	Stable - Unstable	X-No Detection
10	Stable - Unstable	X-No Detection
11	Worked Undecided	X-No Detection
12	Worked Undecided	X-No Detection

13	Worked Undecided	X-No Detection
14	Worked Undecided	X-No Detection
15	Worked Undecided	X-No Detection
16	Worked Undecided	X-No Detection
17	Worked Undecided	X-No Detection
18	X-No Detection	X-No Detection

As a result of the test, the solenoid coil antenna successfully detected up to 8 cm. At 9 and 10 cm, it was stable in some trials and unstable in others. In the spiral antenna design, stable measurements could be made up to 2 cm. According to these results, the use of solenoid antenna gave positive results. According to the test results, the 2nd test circuit and the solenoid antenna will be evaluated.

The SWOT analysis based on the test results is as follows.

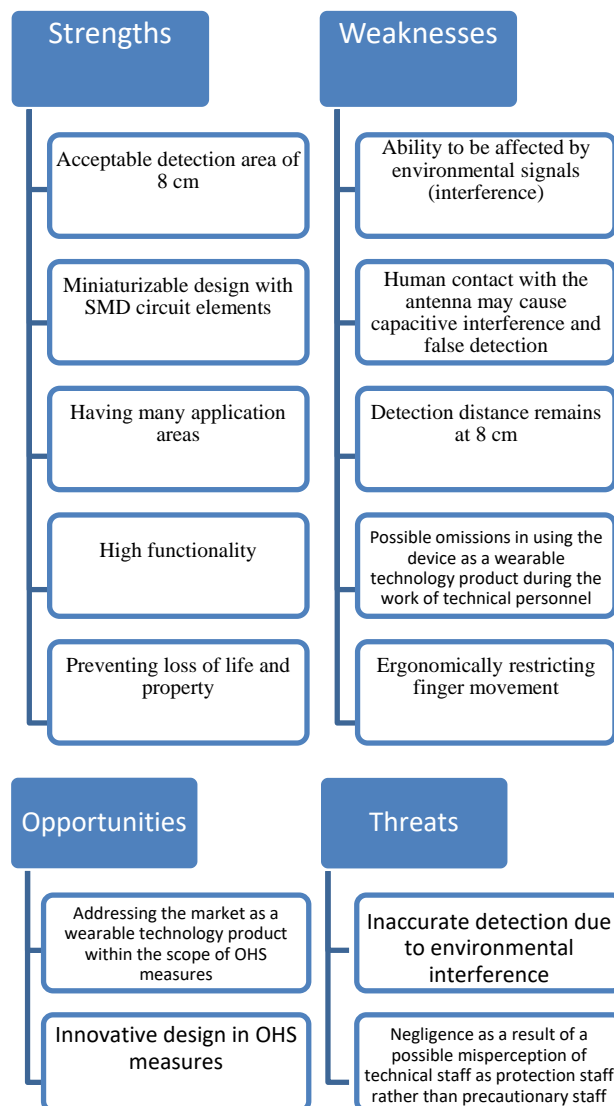
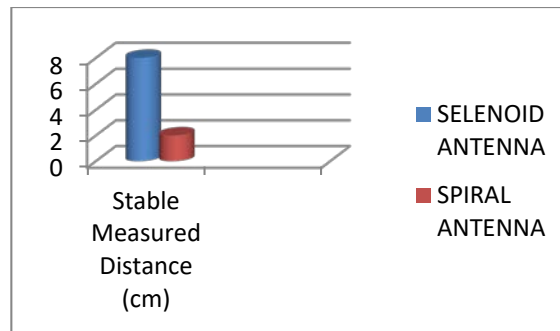

Figure 18. SWOT analysis of the study

As can be seen from the analysis, the design has the potential to be used in the form of an ergonomically appropriate ring.



**Figure 19.** Antenna-detection distance comparison of three transistor darlington connected circuit

As can be seen in Figure 19, the design was tested with two different antennas and the solenoid antenna was able to achieve stable detection up to 8 cm. However, the spiral antenna was stable up to 2 cm.

SWOT analysis and circuit test results show that it works at acceptable distances. However, it needs to be reduced in size and ergonomically designed for the finger so as not to hinder hand movement. It can be reduced to small dimensions with a circuit to be designed using SMD models of circuit elements.

Since it is designed in the shape of a ring and will be reduced to small dimensions, a suitable battery is required. A 1 cell (3.7 V) battery can be used for performance and small size. The energy obtained by using human body heat can also be used to feed the circuit.

If we summarize the existing studies, there are glove, wristband (watch), pen and box shapes for higher voltage levels. When we compare them with technology and fulfillment of their function, we can say that they are designs that work at acceptable levels. The circuit design of this study also detects at acceptable distances. When we examine ergonomically, the studies are large in size. The ring design of this study is smaller in size. Therefore, it is expected to be more comfortable to use. Comparisons were made with the ring design through the designs given in Figure-1, Figure-2 and Figure-3. The design given in Figure-2 is in the form of a box. The design of this study is in the form of a ring (Figure 15).

## 5. CONCLUSION

In this study, we focus on wireless detection of the presence of electrical energy. In the study, it was observed that the three-transistor Darlington-coupled circuit design works more efficiently in detecting electrical energy than the two-transistor Darlington-coupled circuit design. Since the  $\beta$  current gain of the three-transistor circuit is higher than the two-transistor circuit, it increased the current generated in the antenna much more, allowing the LED to light up from longer distances. It was observed that the design works, but it is a fact that it needs to be reduced in size. Considering it as a wearable technology product, its small size is important as it will not restrict ergonomic mobility. The adoption of the ring shape in the design phase is ergonomically more suitable in terms of size than previous studies. The biggest reason for this is that it is a smaller design than, for example, a glove-shaped design. As a result, the study can be used as a wearable technology product that can be used by technical personnel during work if it is reduced to small sizes, free from environmental

interference and ergonomically designed to fit the body. The design is reduced to small dimensions in the form of a ring. In this way, it provided ergonomic working comfort.

## 6. ACKNOWLEDGEMENTS

This research is part of the researcher's master's thesis at Istanbul Gedik University.

## 7. CONFLICT OF INTEREST

There is no conflict of interest or common interest with any institution/organization or person.

## 8. AUTHOR CONTRIBUTION

Burak BOĞAZKESENLİ was responsible for determining and managing the concept and/or design process of the research, data collection, data analysis, and interpretation of the results. He also prepared the manuscript and provided final approval, assuming full responsibility for the work. Aytaç Uğur YERDEN contributed to managing the concept and/or design process of the research, critically analyzing the intellectual content, and provided final approval, taking full responsibility for the work.

## 9. REFERENCES

- Aslan I., Çelik Y., Occupational Health and Safety Investigation of Employees in the Electricity Distribution Sector: Mus, Bitlis and Van Provinces Application. *Journal of Labor Relations* 1, 130-145, 2022. Retrieved from <https://dergipark.org.tr/en/pub/cider/issue/71068/1083460>
- Ates F. M., Teber A., Güngör O., A Study on Basic Precautions Against Electrical Accidents and First Aid. *Bayburt University Journal of Science and Technology* 2(2), 336-347, 2019.
- Ceylan H., Analysis of Occupational Accidents Occurring in Electricity Transmission Facilities in Turkey. *Ejovoc (Electronic Journal of Vocational Colleges)* 2 (1), 98-109, 2012. Retrieved from <https://dergipark.org.tr/tr/pub/ejovoc/issue/5394/73163>
- Crockett C., Gulley J. R., Smith R., Smith C., The Design of a Wearable Non-Contact Voltage Detector.
- Eker H., Solar cell on cotton denim fabric, (Master's thesis, Institute of Science and Technology), 2019.
- Ersoz M., Isıtan A., Balaban M., Nanotechnology 1. BilalOfest Basım-Yayın & Matbaacılık, 2018
- Ertan K., Eldem C., A Study of A Representative Wearable Outer Skelette with Ergonomic Analysis Methods. *Ergonomics* 5(1), 18-25, 2022. <https://doi.org/10.33439/ergonomi.1058235>
- Karabiyik Yerden N., Sustainability, European Green Deal, Marketing and a Research on Automotive Industry. *Istanbul Journal of Social Sciences* 38, 2023.
- Karadeniz O., Work Accidents and Occupational Diseases and Inadequacy of Social Protection in the World and Turkey. *Labor And Society*, 3(34), 15-73, 2012.
- Korkmaz S., GO/ceramic based supercapacitor fabrication and characterization, 2018.
- Kozak M., Kozak S., Energy storage methods. *International Journal of Technological Sciences* 4(2), 17-29, 2012.
- Liu X., Gao H., Sun L., Yao J., Generic Air-Gen Effect in Nanoporous Materials for Sustainable Energy Harvesting from Air Humidity. *Advanced Materials* 2300748, 2023.
- Mamur H., Realization of a computerized data acquisition and test system for the investigation of electrical, thermoelectric and thermal parameters of thermoelectric generator, 2013
- Mutlu M., Cabuk A., Root Cause Analysis in Electrical Accidents in Turkey. *OHS Academic* 3 (1), 15-24, 2021. Retrieved from <https://dergipark.org.tr/en/pub/iscgademik/issue/60198/849432>

- Pamuk O., Yildiz E. Z., Application of Electronic Circuits on Ready-to-Wear Clothing with Embroidery Process. *Dokuz Eylül University Engineering Faculty Science and Engineering Journal* 23(67), 319-325, 2021. <https://doi.org/10.21205/deufmd.2021236728>
- Yang P., Wen X., Ni X., Peng C., A Novel Non-contact AC Voltage Detector Based on Concentric Double-layer Spherical Shell Structure. *Journal of Electronics & Information Technology* 43(6), 1637-1643, 2021. doi: 10.11999/JEIT200286
- Tosun S., An Evaluation on Occupational Health and Safety in Electrical Work. *Journal of Sustainable Engineering Applications and Technological Developments* 5(2), 232-246, 2022. <https://doi.org/10.51764/smutgd.1082589>
- Turgut Z. N., Danişan T., Tamer E., Evaluation and selection of wearable technologies in the world of sports and fashion with CRM methods. *Journal of Sport and Recreation for Everyone* 3(1), 1-11, 2021.
- Turkcan C., Wearable Tissue Electronics. *Beykent University Journal of Science and Engineering Sciences*, 14(1), 27-34, 2021. <https://doi.org/10.20854/bujse.931291>
- Sagbaş E. A., Ballı S., Yildiz T., Wearable smart devices: past, present and future. *Academic Informatics Conference* 30, 749-756, 2016.
- Sezer K. C., Basmacı G., An Overview of Rechargeable Batteries. *Journal of Engineering Sciences and Design* 10(1), 297-309, 2022.
- Zhu J., Lei X., Su Z., Liu T., Liu K., Yu G., Zhu L., Study of Non-contact voltage detector of 1000kV UHV AC based on MEMS electric field sensor. In *MATEC Web of Conferences, EDP Sciences* 160, 02001, 2018.
- Rojaee R., Fathi M., Raessi K., Electrophoretic deposition of nanostructured hydroxyapatite coating on AZ91 magnesium alloy implants with different surface treatments. *Applied Surface Sciences* 285, 664-673, 2013.
- Sanchez-Hernandez Z. E., Dominguez-Cresp M. A., Torres-Huerta A. M., Onofre-Bustamante E., Adame J. A., Dorantes-Rosales H., Improvement of adhesion and barrier properties of biomedical stainless steel by deposition of YSZ coatings using RF magnetron sputtering. *Materials Characterization* 91, 50-57, 2014.
- Song Y. W., Shan D. Y., Han E. H., Electrodeposition of Hydroxyapatite Coating on AZ91D magnesium alloy for biomaterial application. *Material Letters* 62, 3276-3279, 2008.
- Sutha S., Kavitha K., Karunakaran G., Rajendran V., In-vitro bioactivity, biocorrosion and antibacterial activity of silicon integrated hydroxyapatite/chitosan composite coating on 316L stainless steel implants. *Materials Science and Engineering C* 33, 4046-4054, 2013.
- Tan Y. H., Abdullah M. O., Nolasco-Hipolito C., Taufiq-Yap Y. H., Waste ostrich- and chicken-eggshells as heterogeneous base catalyst for biodiesel production from used cooking oil: Catalyst characterization and biodiesel yield performance. *Applied Energy* 160, 58-70, 2015.
- Tangboriboon N., Kunanuruksapong R., Sirivat A., Kunanuruksapong R., Sirivat A., Preparation and properties of calcium oxide from eggshells via calcination. *Materials Science Poland* 30, 313-322, 2012.
- Toygun Ş., Köneçoğlu G., Kalpaklı Y., General principles of sol-gel. *Sigma Journal of Engineering and Natural Sciences*, 31, 456-476. 2013.
- Wei M., Ruys A. J., Swain M. V., Milthorpe B. K., Sorrell C. C., Hydroxyapatite-coated metals: Interfacial reaction during sintering. *Journal of Materials Science: Materials in Medicine* 16, 101-106, 2005.
- Yazdani J., Ahmadian E., Sharifi S., Shahi S., Dizaj S. M., A short view on nanohydroxyapatite as coating of dental implants. *Biomedicine & Pharmacotherapy* 105, 553-557, 2018.

- Yazıcı M., Çomaklı O., Yetim T., Yetim A. F., Çelik A., The effect of plasma nitriding temperature on the electrochemical and semiconducting properties of thin passive films formed on 316L stainless steel implant material in SBF solution. *Surface and Coatings Technology* 261, 181-188, 2015.
- Zhang J. X., Guan R. F., Zhang X. P., Synthesis and characterization of sol-gel hydroxyapatite coating deposited on porous NiTi Alloys. *Journal of Alloys and Compounds* 509, 4643-4648, 2011.
- Zhong Z., Qin J., Ma J., Cellulose acetate/hydroxyapatite/chitosan coatings for improved corrosion resistance and bioactivity. *Materials Science and Engineering: C* 49, 251-255, 2015.
- Zhou Z., Zheng B., Gu Y., Shen C., Wen J., Meng Z., Chen S., Ou J., Qin A., New approach for improving anticorrosion and biocompatibility of magnesium alloys via polydopamine intermediate layer-induced hydroxyapatite coating. *Surfaces and Interfaces* 19, 100501, 2020.