

SOMAK-ASARLIK: A NEW 2nd MILLENNIUM BC FORTRESS NEAR THE BEYCESULTAN

Fulya DEDEOĞLU*

Abstract

Somak-Asarlık, is a fortress type settlement which is located in the north western highlands of Beycesultan Höyük and dominates the routes opening from north and east to the plain of Çivril. Somak-Asarlık, 5.7 km beeline to Beycesultan Höyük, was detected in 2014 within the scope of the systematic archaeological surveys that we have continued to record the prehistoric settlements in the mountainous areas of the districts of Çivril, Çal and Baklan of Denizli in the Upper Menderes Basin since 2010¹. The settlement was founded one of the crests lying to the plain from the plateau in the plateau-plain threshold dividing the parts of the plain and plateau of the basin. This is the most important factor of the selection of the site location placed in a strategic point that sees Beycesultan and its hinterland. Likewise, Beycesultan Höyük might be described as a regional center in the 17th-16th century in which Somak-Asarlık was founded. The excavations have proved that the settlement inhabited around a wide area in 35 hectares and had an advanced organization inside the settlement with the administrative and elite structures in this process. The works about the hinterland feeding a population of Beycesultan Höyük in the characteristics of an administrative center which includes a great population in this process, have revealed the existences of satellite settlements depended on Beycesultan and each of them 4 hectare in size. In this settlement model, Somak-Asarlık might be considered as a part of defensive system protects the hinterland including Beycesultan Höyük and its satellite settlements. In this paper, the archeological data obtained from Somak-Asarlık that we have considered it as a fortress related to Beycesultan Höyük, will be presented in detail and its place in the settlement model of the region will be discussed.

Keywords: *Somak-Asarlık fortress, Beycesultan, the Middle Bronze Age, the Late Bronze Age, Çivril plain, the Meander basin*

SOMAK-ASARLIK: BEYCESULTAN HÖYÜK YAKININDA YENİ BİR 2.BİNYIL KALESİ

Özet

Somak-Asarlık Kalesi yerleşimi, 2014 yılı Yukarı Menderes Havzası Dağlık Kesim Yüzey Araştırması Projesi'nde keşfedilmiştir. Çivril Ovası'nın kuzeybatısını sınırlayan dağlık alanda bulunan kale, ilk olarak MÖ 17-16. yüzyılda kurulmuş ve bu sürecin ardından MÖ 7-6.yüzyıla kadar iskân görmemiştir. Kalenin konumu, Beycesultan ve artalanını gören stratejik bir noktada yer almaktadır ve bu özelliği ile ilişkili bir işlevi olduğu düşünülmektedir. Nitekim bu süreç, Yukarı Menderes Havzası'nda Beycesultan Höyük'ün başını çektiği bir siyasi örgütlenmenin olduğu bir dönemi temsil etmektedir. Mikro ölçekte Somak-Asarlık yerleşiminin detaylı bir şekilde ele alındığı makalede, makro ölçekte MÖ 2. Binyılda bölgede şekillenen yeni bir yerleşim tipinin ortaya konulması hedeflenmektedir. Zira temel geçim ekonomisinin tarıma dayandığı Beycesultan Höyük'ün bünyesindeki nüfusu besleyen geniş art alanı ve bu art alan içine giren "uydu yerleşimler"i barındırdığı ve bu yapılanmanın güvence altına alınmasının siyasi ve ekonomik açıdan son derece önemli olduğu söylenebilir. Somak-Asarlık Kalesi'nin görüş alanını analizi sonuçları, yerleşimin Beycesultan'ı ve art alanını merkeze alan bir noktada konumlandığını göstermektedir. Bu bağlamda Somak-Asarlık örneğinin MÖ 2. binyılda, Beycesultan

* Yrd. Doç.Dr. Ege Üniversitesi, Edebiyat Fakültesi Arkeoloji Bölümü, Protohistorya ve Önasya Arkeolojisi Anabilim Dalı, Bornova/İzmir
e-posta: dedeoglufulya@hotmail.com.

¹ Dedeoğlu vd., 2016: 557.

Höyük merkezli sosyo-ekonomik örgütlenmenin tarımsal girdisini sağlayan art alanının güvenliğinin nasıl sağlandığını göstermesi açısından da iyi bir model sunduđu düşünülmektedir.

Anahtar Kelimeler: *Somak-Asarlık Kalesi, Beycesultan, Orta Tunç Çağı, Geç Tunç Çağı, Çivril Ovası, Büyük Menderes*

THE FORTRESS OF SOMAK-ASARLIK

Somak-Asarlık was constructed on a volcanic hill in the height of 960 m from the sea level, locating in the borders of the Somak village of the Çivril District in the Denizli Province, and 135 m from the plain level. The crest that the fortress is situated is isolated from the topography around it with a narrow and deep valley from the north and south directions. The only passing point of the settlement which might be relatively described as flat and provide the connection with the field around it, is the part connecting to the northwestern hillsides of the settlement. (Fig.7), The crest on which the settlement exists, has a direction of northwest-southeast, and its altitude shows differences when the topography increases through the east in parallel with the settlement's direction. The difference of the level between two ends of the settlement is approximately 30 meters. The altitude alters between 945-950 meters in the middle part. There are stone lines which might be followed from the surface and probably related to the fortification wall (Fig.8), in the settlement lying to approximately 1 hectare. Especially in the north western area of the settlement, 2,70 x 0,50 m foundations consisting of big-size stones, should be a part of the fortification wall.

During the systematic survey carried out in the settlement, many ceramic finds have been detected. Due to the fact that the topography of the settlement does not show

a specific distinction in itself and due to the slope, collecting the surface material has been carried out in the whole settlement instead of creating specific areas². The finds on the settlement, show that the settlement area was inhabited in the early period of the Late Bronze Age and the Iron Age.

All of the finds from Somak-Asarlık consist of ceramics. Among the most frequent pottery forms in the ceramics we date to the early process of the Late Bronze Age that generates the main subject of the paper, interior and exterior thickened rim and hemispherical bowls (Fig. 1: 1-6) or pots (Fig.1: 11) stand out. Whereas the upper sides of the rims of some of the subject wares were flattened (Fig. 1: 2, 5-6), some of them were left as globular (Fig. 1: 1, 3-4, 11).

² The method we generally use in gathering the surface finds is to gather the finds inside "sample areas" formed as appropriate to the settlement's topography. However, it has been thought that forming any gathering area on the site would be insignificant since slope abundantly exists in Somak-Asarlık.

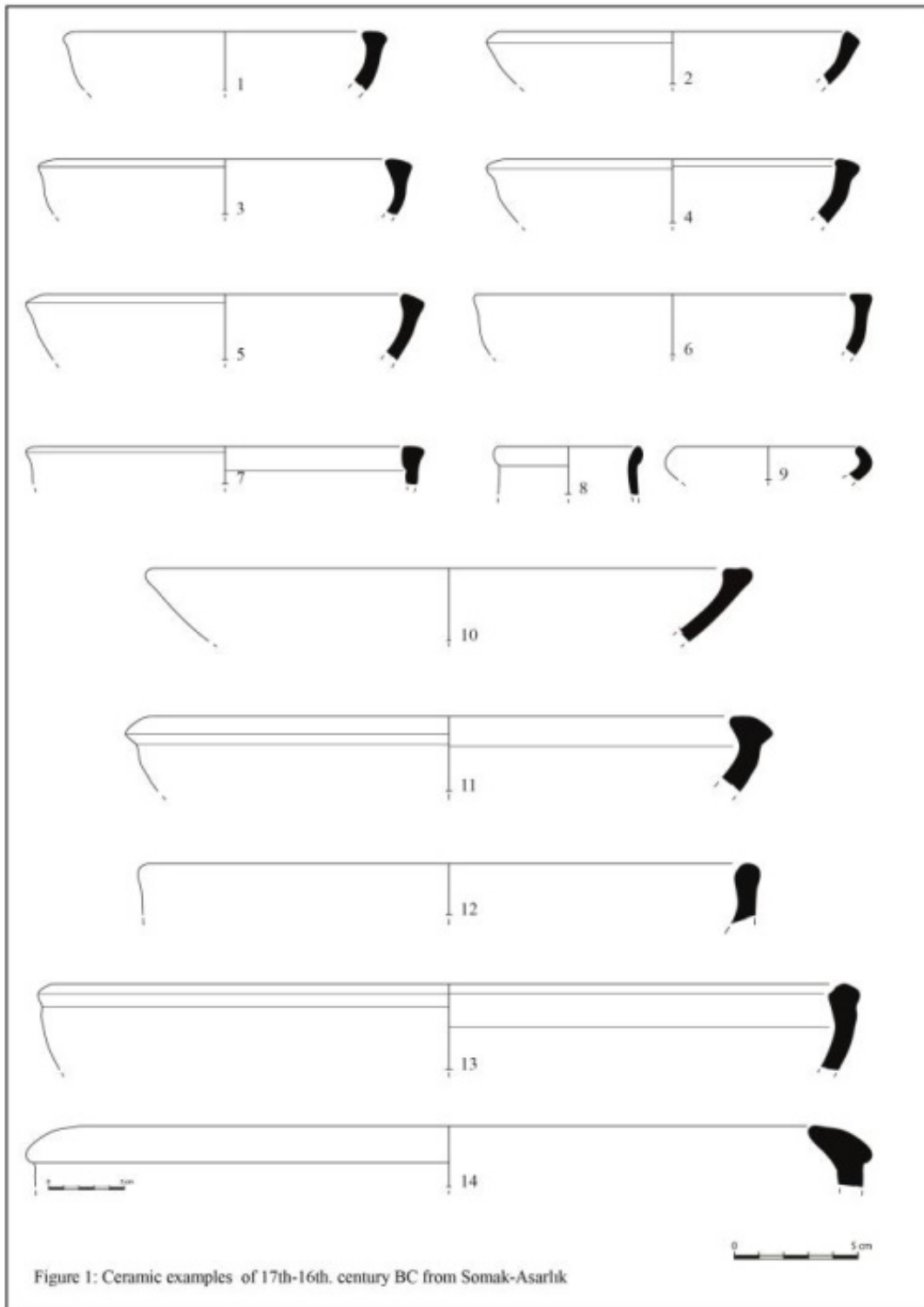

Flaring rim (Fig. 1: 13), and inverted and flaring rim (Fig. 1: 14) deep bowls, inverted and flaring (Fig. 1: 10) or flaring rim plates (Fig. 2: 1-2) are among the

other forms. Besides the potsherds which might be belonged to limited jugs (Plate 1: 8; Plate 2: 3-4), goblet (Plate 1: 9)

and pots (Fig. 1: 7; Fig. 2: 5-6), ring (Fig. 2: 7, 9, 11) and flat (Fig. 2: 8, 10) shaped bases and horizontal handles (Fig. 2: 13-

15) are among the ceramic samples found at the settlement.

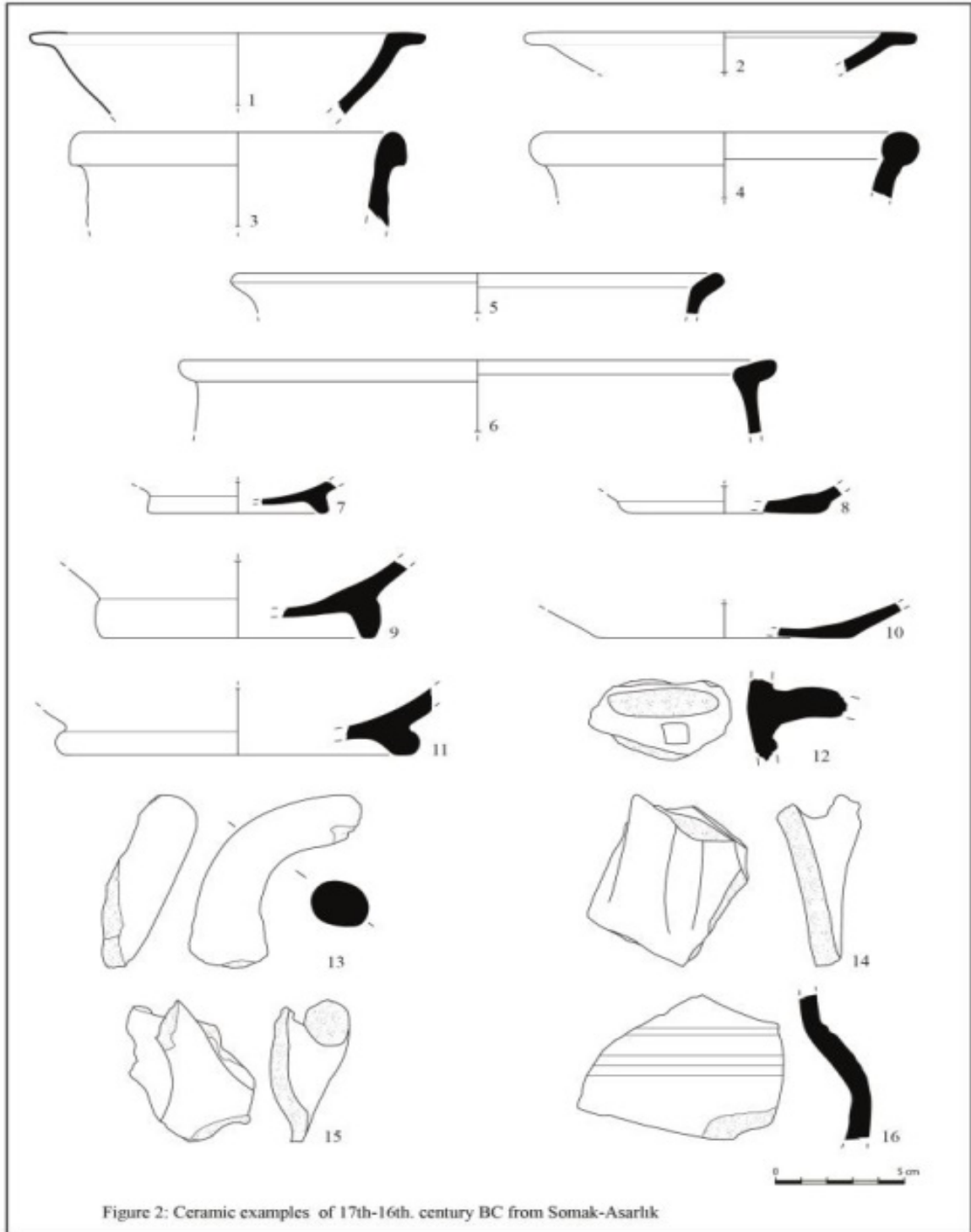

Especially slip and burnish processes of the ceramics have been largely ruined due to the long standing on surface and

generally a small part of the ceramic has been preserved (Fig.3).

Somak-Asarlık: A New 2nd Millennium Bc Fortress Near the Beycesultan

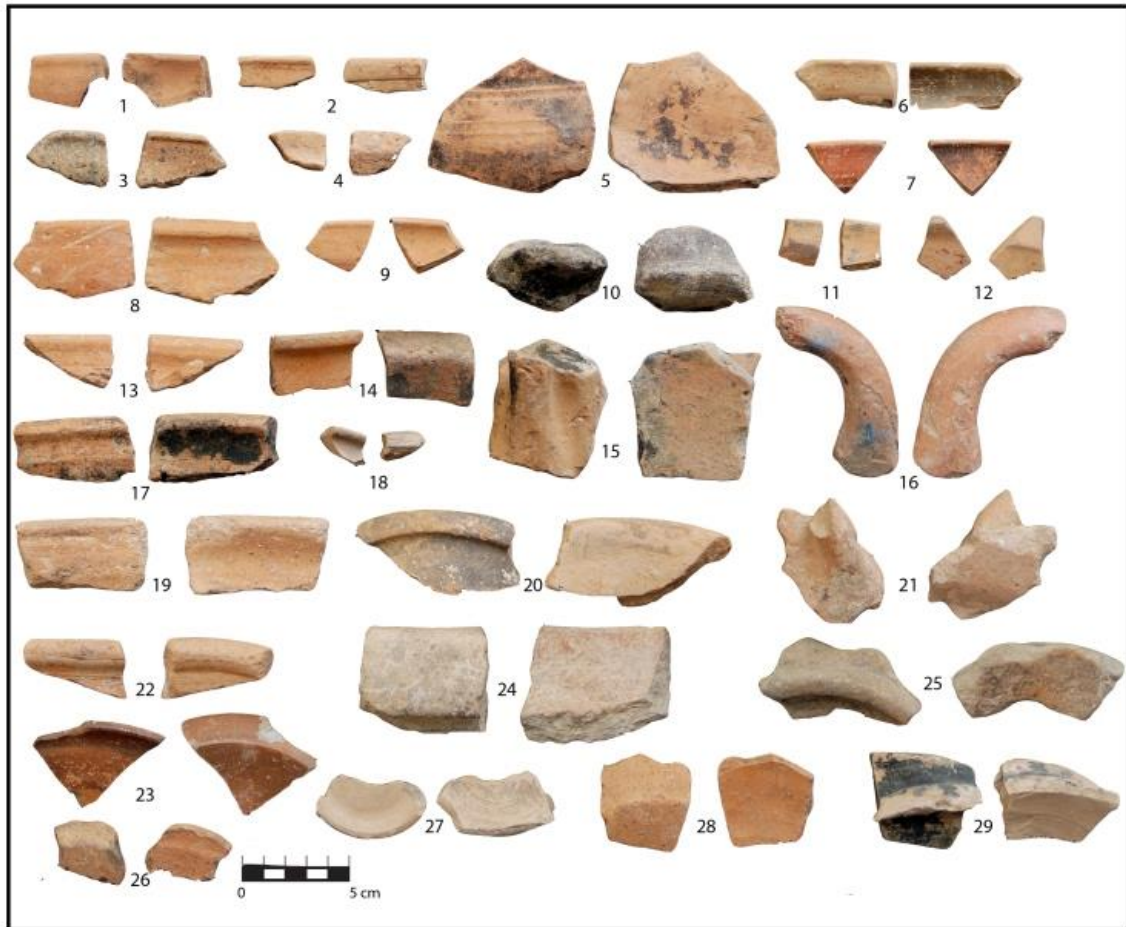

Figure 3: Ceramics of 17th-16th. century BC from Somak-Asarlık

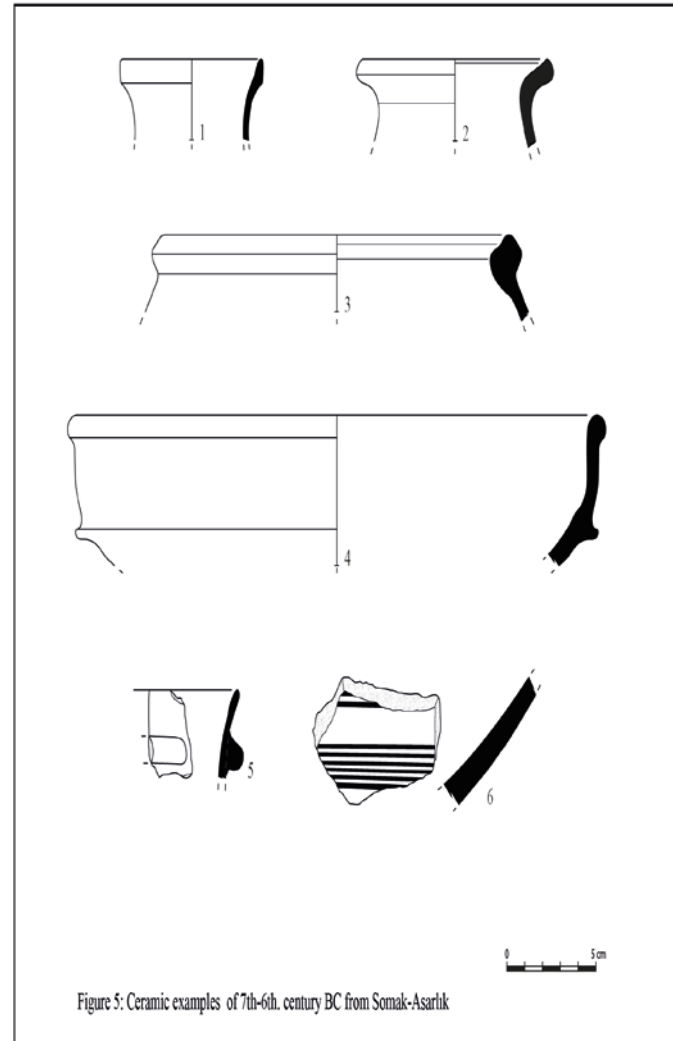

Figure 4: Ceramics of 7th-6th. century BC from Somak-Asarlık

Slip and burnish have been seen nearly in the whole of the ceramics and it has been understood that they were wheel-made.

Among the ceramics, the most common group consists of red or red-brown surface ceramics.

The paste colour of this group is more light brown and brick color, and mainly has grit or grit-lime temper (Fig. 3). The paste colour of another ceramic group with grey surface is predominantly brown and has grit and lime temper. The potteries found in the settlement, are completely similar to particularly the Layer 5b of Beycesultan³. For instance, the analogies of flaring rim plates⁴ (Fig. 2: 1-2) and interior – exterior thickened rim and hemispherical bowls and pots⁵ were found in Beycesultan in the manners of both ware groups and forms. Besides this great closeness with the Layer 5 of Beycesultan, it is seen that it shows some similarities with the settlements such as Aphrodisias⁶, Panaztepe⁷, Troia⁸, Bademgediği Tepe⁹, especially when vertical handles and interior and exterior thickened bowls are considered.



The limited ceramic sample shows that Somak-Asarlık was inhabited in the Iron Age after the Late Bronze. Besides the red and brown slipped monochrome samples, the ware dated to the 7th-6th century BC on which parallel red horizontal band decoration is seen (Fig. 5, Fig. 3), is remarkable.

³ In the stratigraphy determined by S.Lloyd and J. Mellaart, it corresponds to the Layer II.

⁴ Dedeoğlu and Abay, 2014: 9, Fig 27:6-9, Mellaart and Murray, 1995: P17:13-14, Pl 18a: 10.

⁵ Mellaart and Murray, 1995: P17:5-7-8-10.

⁶ Joukowsky, 1986: Fig 307: 9, 21

⁷ Günel, 1999: Lev.1-5.

⁸ Blegen et al., 1951: Fig 251: 11-17.

⁹ Meriç, 2003: 92, Fig.14, 11.

Besides the surface surveys in the Upper Menderes Basin¹⁰, the analogies of these ceramics found in the settlement and known as the description of “Black on Red Pottery” in litterateur, have been found during the excavations of Sardes¹¹, Aphrodisias¹², Uylupınar¹³, Asopos Tepesi¹⁴ and Tabae¹⁵. Also, sharp shouldered bowl, flaring rim pots and inverted rim, exterior thickened rim pots dated to the Iron Age, have been found at the settlement.

CONCLUSION

It has been understood that the Somak-Asarlık fortress situated in a high, protected and strategic location, had a relatively short inhabiting dated to the 17th-16th century that we define as the early period of the Late Bronze Age. It has been comprehended that the fortress was abandoned after this period, and was never settled except the limited inhabiting in the Iron Age. A massive fire layer in Beycesultan Höyük corresponds with the period that Somak-Asarlık was abandoned. This homogeneity brings to mind that an event affecting the common region, might be lived. Likewise, it has been thought that the massive destruction in this process corresponding to the Layer 5 of Beycesultan Höyük¹⁶ resulted from an invasion as many human skeletons found in the settlement, support¹⁷. However there is no information about which community executed this invasion. The limited data about the political structure of the region come from the written sources of the

Hittites¹⁸ and give information that the region is a part of the lands of Arzawa. It has been understood from the written sources that the Land/s of Arzawa including various kingdoms and consisting of different political units in this context, were tried to be kept under the control of the Hittite Kingdom. It has been also mentioned that the communities of Arzawa occasionally revolt against this situation¹⁹. The archeological data such as the palace, public buildings, temples and elite structures detected at Beycesultan Höyük, show that the settlement was a regional center in the political and economic manners in the lands of Arzawa in this process²⁰. At the same time, the settlement includes a great population with being inhabited in an extremely large area spreading over two cones. That the main subsistence economy of the community forming population, is based upon agriculture, has been understood from both the location of the settlement and the structures in which a huge amount of cereals is stored²¹.

¹⁰ Mellaart, 1955: 115 vd, Abay and Dedeoğlu, 2005: 282, Yeni, 2010, Dedeoğlu et al., 2014: 370, Dedeoğlu et al., 2015: 156.

¹¹ Gürtekin, 1998.

¹² Joukowsky, 1986: 119.

¹³ Çokay, 2009: 29.

¹⁴ Konakçı, 2014: 94.

¹⁵ Gürtekin et al., 2015: 122.

¹⁶ The Layer 5b is contemporary to the Layer II in the excavation researches of the first period.

¹⁷ Abay, 2012: 58; Dedeoğlu and Abay, 2015: 10.

¹⁸ Houwink ten Cate, 1970: 71; Heinhold-Krahmer, 1977: 4; del Monte and Tischler, 1978: 42.

¹⁹ Latacz, 2002: 196; Karauğuz, 2002: 139-140; Bryce, 1980: 135.

²⁰ Lloyd and Mellaart, 1955: 43-52; Lloyd and Mellaart, 1956: 106-123; Lloyd and Mellaart, 1965: 3-34.

²¹ Abay, 2014: 179-180.

In this context, Beycesultan Höyük, a typical “Plain Settlement”, should have a large hinterland which feeds the population of it. The analyses have shown that this hinterland is approximately 1120 hectares²². In that area, there are four more settlements which are clustered around Beycesultan might be defined as “satellite settlements”. These settlements, each of them is in the size of 4 hectares, are Yamanlar Höyük, Sökmen Höyük, Çatal Höyük and Yakacık Höyük. Securing Beycesultan Höyük of which main subsistence economy is agriculture, and its background which includes both Beycesultan itself and the settlements above, should be extremely significant in the political and economic manners.

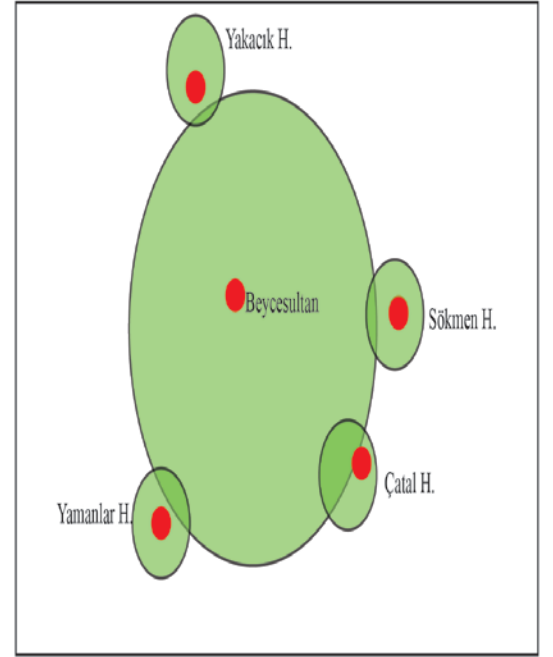

Figure 6: Agricultural sustaining area of the Beycesultan and other sites around.

²² While the hinterland of Beycesultan Höyük was been calculating, it was used an estimation that 80% of each individual needed 3100 calories only from wheat products per a day, and this estimation was equal to approximately 320 kg whole grain wheat in a year (Hillman 1973: fig 2; Lupton 1996: 22). In the calculation of the agricultural usage area that this estimation requires, the records of the Republic Period of Turkey (Taşkın and Karaçam, 2006: 49) and the works of “Temettüat Defterleri” (profits and earnings registries) of the region in the Ottoman Period have been evaluated. (Özçelik, 2001; 2007).

Somak-Asarlık: A New 2nd Millennium Bc Fortress Near the Beycesultan

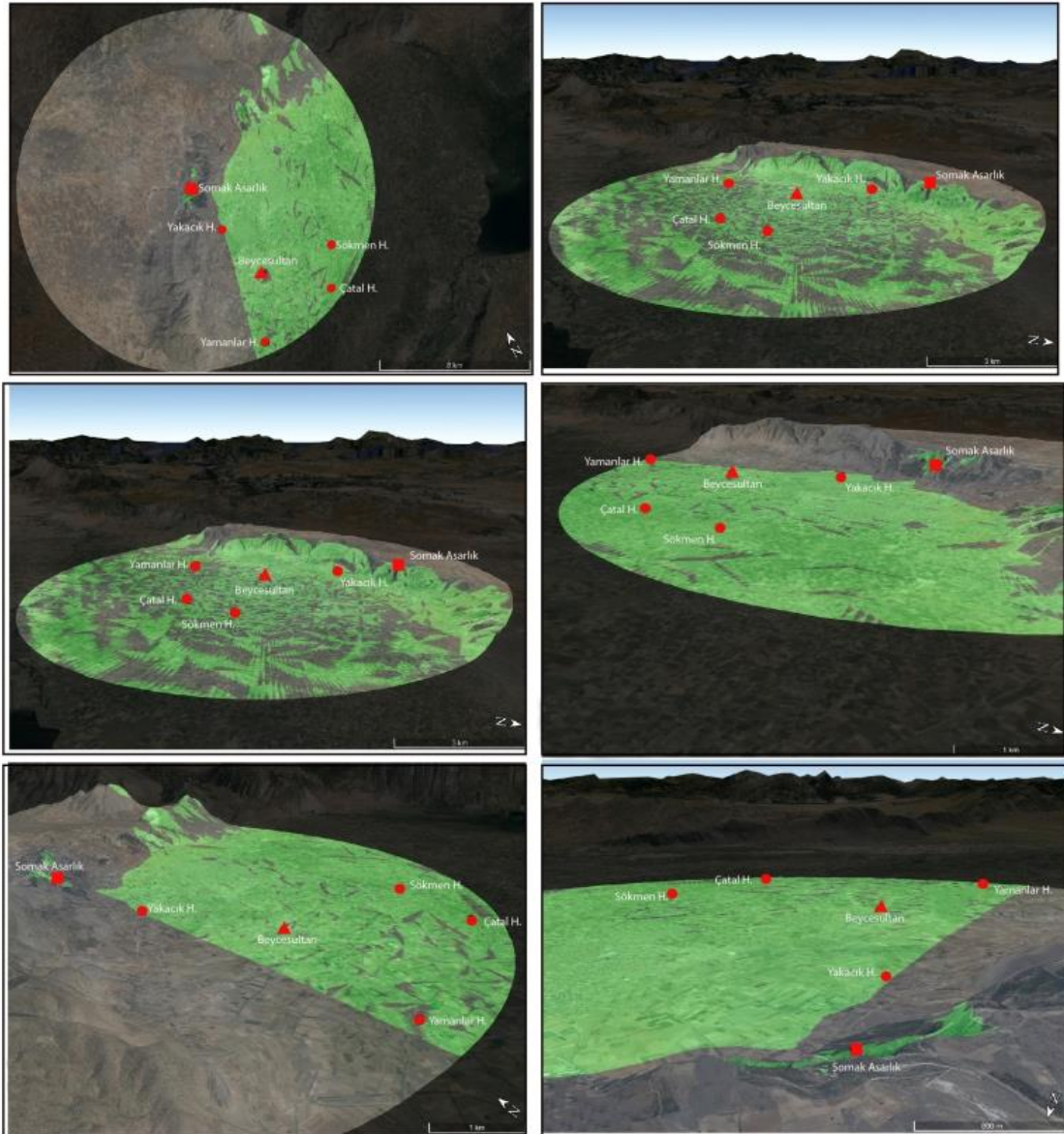

Figure 7: The viewshed analyse of Somak-Asarlık from different directions.

At this point, the location of the Somak-Asarlık fortress is seen related to this function of the settlement. Likewise, the result of viewshed analyses of Somak-Asarlık indicates that the fortress is located in a point centralizing Beycesultan and its hinterland. In this context, Somak-Asarlık

fortress offers a better model to show how the security of its hinterland which supplies the agricultural input of the socio-economic organization based on Beycesultan Höyük, was provided in the second millennium BC.



Figure 8: Somak-Asarlık fortress from north.



Figure 9: Fortification wall (?) remains from Somak-Asarlık.

BIBLIOGRAPHY

- Abay, E. (2012). "Beycesultan", **Ege Üniversitesi Arkeoloji Kazıları**, (Ed: A. Çilingiroğlu, Z. Mercangöz, G. Polat), İzmir, 39-64.
- Blegen C., Caskey J.L., Rawson M. (1951). **Troy II: The Third, Fourth and Fifth Settlements**, Princeton University Press.
- Bryce, T. R. (1980). **The Major Historical Texts of early Hittite History**, Asian Studies Monograph 1, Queensland.
- Çokay-Kepçe, S. (2009), "The Pottery from Burdur Uylupınar Necropolis", **Adalya**, XII, 29-77.
- Dedeoğlu F., Konakçı E., Çarkı M., (2014). "Yukarı Menderes Havzası Dağlık Kesim Yüzey Araştırması Projesi 2012 Yılı Çalışmaları", **Araştırma Sonuçları Toplantısı**, 31/2, 367-376.
- Dedeoğlu, F. Ozan, A. Konakçı, E. (2016). "Yukarı Menderes Havzası Dağlık Kesim Yüzey Araştırması Projesi 2014 yılı Çalışmaları" **Araştırma Sonuçları Toplantısı**, 33/2, 553-562.
- Dedeoğlu, F. and Abay, E. (2014). "Beycesultan Höyük Excavation Project: New Archaeological Evidence from Late Bronze Age Layers" **Arkeoloji Dergisi**, 19, 1-39.
- del Monte, G.F. and Tischler, J. (1978). **Repertoire Geographique des Textes Cuneiformes VI: Die Orts- und Gewässernamen der hethitischen Texte**, Wiesbaden.
- Günel, S. (1999). **Panaztepe II, MÖ II. Bine Tarihlendirilen Panaztepe Seramiğinin Batı Anadolu ve Ege Arkeolojisindeki Yeri ve Önemi**, TTK, Ankara.
- Gürtekin R.G. (1998). **Lydia Seramiğindeki Yabancı Etkiler**, (Yayınlanmamış Doktora Tezi), Ege Üniversitesi Sosyal Bilimler Enstitüsü, İzmir.
- Gürtekin-Demir, G. ve Polat, Y. (2015) "Between Lydia and Caria: Iron Age Pottery From Kaale-i Tavas, Ancient Tabae", **KERAMOS Ceramics: A Cultural Approach, Proceedings of the first International Conference at Ege University**, (Ed: Gürtekin-Demir R.G., Cevizoğlu H., Polat Y., Polat G.) Bilgin Kültür Sanat Yayınları.
- Heinhold-Krahmer, S. (1977). **Arzawa. Untersuchungen zu einer Geschichte nach den hethitischen Quellen (= THeth 8)**, Heidelberg.
- Hillman 1973: şekil 2; "Agricultural Productivity and Past Population Potential at Aşvan", **Anatolian Studies**, 23, 225-240.
- Houwink ten Cate, P.H.J. (1970). **Records of the Early Hittite Empire (1450-1380 BC), Uitgaven van het Nederlands Historisch-Archaeologisch Instituut de Istanbul 26**, İstanbul.
- Joukowsky, M.S. (1986). **Prehistoric Aphrodisias, An Account of the Excavations and Artifact Studies, Vol I-II, Excavations and Studies**, New Jersey.
- Latacz, J. (2002). "Wilusa (Wilios/Troia): Zentrum eines hethitischen Gliedstaates in Nordwest-Kleinasien", **Hititler ve Hitit İmparatorluğu**, 196-201.
- Karauğuz, G. (2002). **Boğazköy ve Ugarit Çivi Yazılı Belgelerine Göre Hitit Devletinin Siyasi Antlaşma Metinleri**, Konya.
- Krahmer, S. H. (1977). **Arzawa, Untersuchungen zu Einer Geshichte nach den Hethetischen Quellen**, Heidelberg.
- Konakçı, E. (2014). "Laodikeia'nın İlk Yerleşimi Asopos Tepesi (First Settlement of Laodikeia: Asopos Hill)", **10. Yılında Laodikeia (2003-2013 Yılları)**, (Ed: C. Şimşek), Ege Yayınları, 87-123.
- Lloyd, S. and Mellaart, J. (1955). "Beycesultan Excavations: First Preliminary Report", **Anatolian Studies**, 5, 39-92.

- Lloyd, S. and Mellaart, J. (1956). "Beycesultan Excavations: Second Preliminary Report, 1955" **Anatolian Studies**, 6, Special Number in Honour and in Memory of Professor John Garstang, 101-135.
- Lloyd, S. and Mellaart, J. (1965). **Beycesultan Vol.II: Middle Bronze Age Architecture and Pottery**, London.
- Lupton, A. (1996). *Stability and Change: socio-political development in north Mesopotamia and south-east Anatolia, 4000-2700 B.C.*, London, BAR International series 627.
- Mellaart, J. (1955). "Iron Age Pottery from Southern Anatolia", **Belleten**, XIX/74, 115-140.
- Mellaart, J. ve Murray, A. (1995). **Beycesultan Vol. III Part II: Late Bronze Age and Phrygian Pottery and Middle and Late Bronze Age Small Objects**, Oxford.
- Meriç, R. (2003). "Excavations at Bademgediği Tepe (Puranda) 1999-2002: A preliminary Report", **IstMitt** 53, 79-98.
- Taşkın-Karaçam, N. (2006). **Denizli Ekonomisi 1920-1980**, (Yayınlanmamış Yüksek Lisans Tezi), Pamukkale Üniversitesi Sosyal Bilimler Enstitüsü, Denizli.
- Özçelik, S. (2001). "Temettuat Defterlerine Göre 1844 yılında Çivril'de İktisadi ve Sosyal Hayat" **Dünden Bugüne Çivril Sempozyumu**, Ankara, 201-227.
- Özçelik, S. (2007). "XIX. yüzyıl Ortalarında Çal (Demirci) ve Zeyve'de (Akkent) Sosyo-Ekonomik Hayat" **21. Yüzyıla Girerken Geçmişten Günümüze Çal Yöresi**, Denizli, 305-328.
- Yeni, S. (2010). **Demir Çağlar'da Yukarı Menderes Havzası**, (Yayınlanmamış Yüksek Lisans Tezi), Ege Üniversitesi Sosyal Bilimler Enstitüsü, İzmir.

CATALOG

Figure 1:

- 1.Ceramic No: DB/76/03, Fabric Colour: 5YR7/6 Interior Colour: 2,5YR 5/8 Exterior Colour: 2,5YR 5/8 Inclusions: Sand, lime Exterior: Burnished Interior: Burnished Firing: Hard, wheel-made.
- 2.Ceramic No: DB/76/28, Fabric Colour: 5YR7/4 Interior Colour: 5YR 5/2 Exterior Colour: 5YR 5/2 Inclusions: Grit, lime Exterior: Burnished Interior: Burnished Firing: Hard, wheel-made.
- 3.Ceramic No: DB/76/18, Fabric Colour: 5YR7/4 Interior Colour: 5YR 5/1 Exterior Colour: 5YR 5/6 Inclusions: Sand, Exterior: Burnished Interior: Burnished Firing: Hard, wheel-made.
- 4.Ceramic No: DB/76/24, Fabric Colour: 7,5YR7/4 Interior Colour: Unslipped Exterior Colour: 7,5YR 6/1 Inclusions: Grit, lime, Exterior: Burnished Interior: Unburnished Firing: Hard, wheel-made.
- 5.Ceramic No: DB/76/25, Fabric Colour: 2,5YR 6/6 Interior Colour: 2,5YR 6/6 Exterior Colour: 2,5YR 6/6 Inclusions: Sand, Exterior: Unburnished Interior: Unburnished Firing: Hard, wheel-made.
- 6.Ceramic No: DB/76/19, Fabric Colour: 5YR6/6 Interior Colour: 2,5YR 5/6 Exterior Colour: 2,5YR 5/6 Inclusions: Sand, Exterior: Burnished Interior: Burnished Firing: Hard, wheel-made.
- 7.Ceramic No: DB/76/23, Fabric Colour: 7,5YR 8/3 Interior Colour: 2,5YR 5/8 Exterior Colour: 2,5YR 5/8 Inclusions: Sand, Exterior: Burnished Interior: Burnished Firing: Hard, wheel-made.

8. **Ceramic No:** DB/76/30, **Fabric Colour:** 5YR 6/6 **Interior Colour:** Unslipped **Exterior Colour:** Unslipped **Inclusions:** Sand, **Exterior:** Unburnished **Interior:** Unburnished **Firing:** Hard, wheel-made.
9. **Ceramic No:** DB/76/29, **Fabric Colour:** 5YR 7/2 **Interior Colour:** 5YR 5/2 **Exterior Colour:** 5YR 5/2 **Inclusions:** Sand, **Exterior:** Burnished **Interior:** Burnished **Firing:** Hard, wheel-made.
10. **Ceramic No:** DB/76/02, **Fabric Colour:** 5YR7/6 **Interior Colour:** 2,5YR 6/6 **Exterior Colour:** 2,5YR 6/6 **Inclusions:** Grit, lime **Exterior:** Burnished **Interior:** Burnished **Firing:** Hard, wheel-made.
11. **Ceramic No:** DB/76/20, **Fabric Colour:** 5YR6/6 **Interior Colour:** 2,5YR 6/6 **Exterior Colour:** 2,5YR 6/6 **Inclusions:** Grit, lime, **Exterior:** Burnished **Interior:** Burnished **Firing:** Hard, wheel-made.
12. **Ceramic No:** DB/76/21, **Fabric Colour:** 2,5YR7/6 **Interior Colour:** Unslipped **Exterior Colour:** Unslipped **Inclusions:** Grit, **Exterior:** Unburnished **Interior:** Unburnished **Firing:** Hard, wheel-made.
13. **Ceramic No:** DB/76/04, **Fabric Colour:** 5YR6/6 **Interior Colour:** Unslipped **Exterior Colour:** 2,5YR 6/3 **Inclusions:** Grit, lime, mica **Exterior:** Burnished **Interior:** Unburnished **Firing:** Hard, wheel-made.
14. **Ceramic No:** DB/76/12, **Fabric Colour:** 5YR6/4 **Interior Colour:** 5YR6/4 **Exterior Colour:** 5YR6/4 **Inclusions:** Grit, organic **Exterior:** Unburnished **Interior:** Unburnished **Firing:** Hard, wheel-made.

Figure 2:

1. **Ceramic No:** DB/76/08, **Fabric Colour:** 7,5YR 5/4 **Interior Colour:** 7,5YR 4/4 **Exterior Colour:** 7,5YR 4/4 **Inclusions:** Sand **Exterior:** Burnished **Interior:** Burnished **Firing:** Hard, wheel-made.
2. **Ceramic No:** DB/76/26, **Fabric Colour:** 5YR 7/4 **Interior Colour:** 5YR 5/6 **Exterior Colour:** 5YR 5/6 **Inclusions:** Sand, lime, **Exterior:** Burnished **Interior:** Burnished **Firing:** Hard, wheel-made.
3. **Ceramic No:** DB/76/10, **Fabric Colour:** 7,5YR 8/3 **Interior Colour:** Unslipped **Exterior Colour:** 7,5YR 5/1 **Inclusions:** Grit, lime, **Exterior:** Burnished **Interior:** Unburnished **Firing:** Hard, wheel-made.
4. **Ceramic No:** DB/76/17, **Fabric Colour:** 5YR 6/6 **Interior Colour:** 2,5YR 6/8 **Exterior Colour:** 2,5YR 6/8 **Inclusions:** Grit, **Exterior:** Burnished **Interior:** Unburnished **Firing:** Hard, wheel-made.
5. **Ceramic No:** DB/76/27, **Fabric Colour:** 5YR 6/6 **Interior Colour:** Unslipped **Exterior Colour:** Unslipped **Inclusions:** Grit, lime, **Exterior:** Unburnished **Interior:** Unburnished **Firing:** Hard, wheel-made.
6. **Ceramic No:** DB/76/16, **Fabric Colour:** 5YR 6/8 **Interior Colour:** 2,5YR 6/8 **Exterior Colour:** 2,5YR 6/8 **Inclusions:** Grit, lime, mica **Exterior:** Burnished **Interior:** Burnished **Firing:** Hard, wheel-made.
7. **Ceramic No:** DB/76/06, **Fabric Colour:** 7,5 YR8/3 **Interior Colour:** 7,5YR 6/1 **Exterior Colour:** 7,5YR 6/1 **Inclusions:** Sand **Exterior:** Burnished **Interior:** Burnished **Firing:** Hard, wheel-made.
8. **Ceramic No:** DB/76/22, **Fabric Colour:** 5 YR7/6 **Interior Colour:** 2,5YR 6/6 **Exterior Colour:** 2,5YR 6/6 **Inclusions:** Grit **Exterior:** Burnished **Interior:** Unburnished **Firing:** Hard, wheel-made.
9. **Ceramic No:** DB/76/14, **Fabric Colour:** 7,5YR8/4 **Interior Colour:** Unslipped **Exterior Colour:** Unslipped **Inclusions:** Sand, lime **Exterior:** Unburnished **Interior:** Unburnished **Firing:** Hard, wheel-made.

- 10. Ceramic No:** DB/76/15, **Fabric Colour:** 5YR6/6 **Interior Colour:** Unslipped **Exterior Colour:** Unslipped **Inclusions:** Grit, lime **Exterior:** Unburnished **Interior:** Unburnished **Firing:** Hard, wheel-made.
- 11. Ceramic No:** DB/76/01, **Fabric Colour:** 5YR7/8 **Interior Colour:** 5YR 6/2 **Exterior Colour:** 5YR 6/2 **Inclusions:** Grit, lime **Exterior:** Burnished **Interior:** Burnished **Firing:** Hard, wheel-made.
- 12. Ceramic No:** DB/76/11, **Fabric Colour:** 10 YR8/3 **Exterior Colour:** 10 YR 6/1 **Inclusions:** Grit **Exterior:** Burnished **Firing:** Hard.
- 13. Ceramic No:** DB/76/05, **Fabric Colour:** 2,5 YR6/4 **Exterior Colour:** 2,5YR 6/6 **Inclusions:** Grit, lime, **Exterior:** Burnished **Firing:** Hard.
- 14. Ceramic No:** DB/76/13, **Fabric Colour:** 5YR7/6 **Interior Colour:** 5YR7/6 **Exterior Colour:** 5YR7/6 **Inclusions:** Grit, lime **Exterior:** Unburnished **Interior:** Unburnished **Firing:** Hard, wheel-made.
- 15. Ceramic No:** DB/76/07, **Fabric Colour:** 2,5 YR7/6 **Exterior Colour:** 2,5YR7/6 **Inclusions:** Grit, lime **Exterior:** Burnished **Firing:** Hard.
- 16. Ceramic No:** DB/76/09, **Fabric Colour:** 5YR 6/6 **Interior Colour:** 5YR 6/8 **Exterior Colour:** 5YR 6/8 **Inclusions:** Grit, lime **Exterior:** Burnished **Interior:** Unburnished **Firing:** Hard, wheel-made.