

**A SELECTIVE SEARCH FOR BIOLOGICALLY ACTIVE TRIPARTATE  
NUCLEOSIDE PRODRUGS: II**

**BİYOLOJİK AKTİVİTESİ OLAN ÜÇ KISIMLI NÜKLEOSİT PRODRUG'LARI  
İÇİN SEÇİCİ BİR TARAMA: II**

**Süreyya Ölgün**

Ankara Üniversitesi, Eczacılık Fakültesi, Farmasötik Kimya Anabilim Dalı  
06100 Tandoğan-Ankara

**ABSTRACT**

*In the previous review, among the bipartate and tripartate prodrug approaches, it was only explained bipartate prodrugs. In this review, it was explained the tripartate prodrug approach and recent progress in the design and synthesis tripartate prodrug nucleosides. It was determined that the tripartate approach applied to pronucleotides appears to be very effective in vitro, but toxicity and solubility, as well as synthetic methodology issues should be taken into consideration.*

**Key words:** Nucleosides, Tripartate approaches, Syntheses

**ÖZET**

*Bir önceki derlemede, bipartat ve tripartat önilaç yaklaşımları arasından sadece bipartat önilaç yaklaşımı açıklanmıştır. Bu derlemede, tripartate önilaç yaklaşımı ve tripartat önilaç nükleositlerin tasarım ve sentezlerindeki son gelişmeler açıklanmıştır. Tripartat yaklaşımının, önilaçlara uygulamasının in vitro olarak oldukça etkili olduğu, fakat sentetik metodoloji yanısıra toksisite ve çözünürlüğün de göz önünde bulundurulması gerektiği tespit edilmiştir.*

**Anahtar kelimeler:** Nükleositler, Tripartat yaklaşım, Sentezler.

## INTRODUCTION

Failure of the bipartate drug approach can be associated with the instability of the linkage between carrier and drug or electronic and steric properties of the prodrug as a whole hindering enzymatic cleavage. In either case, the tripartate prodrug approach may overcome these complications by placing a spacer between the carrier and the drug so that the enzymatic cleavage occurs between carrier and spacer instead of between carrier and drug (Figure 1). Once the bond linking carrier and spacer is cleaved, the remaining bond connecting spacer and drug undergoes spontaneous hydrolysis under physiological conditions releasing the drug (1).

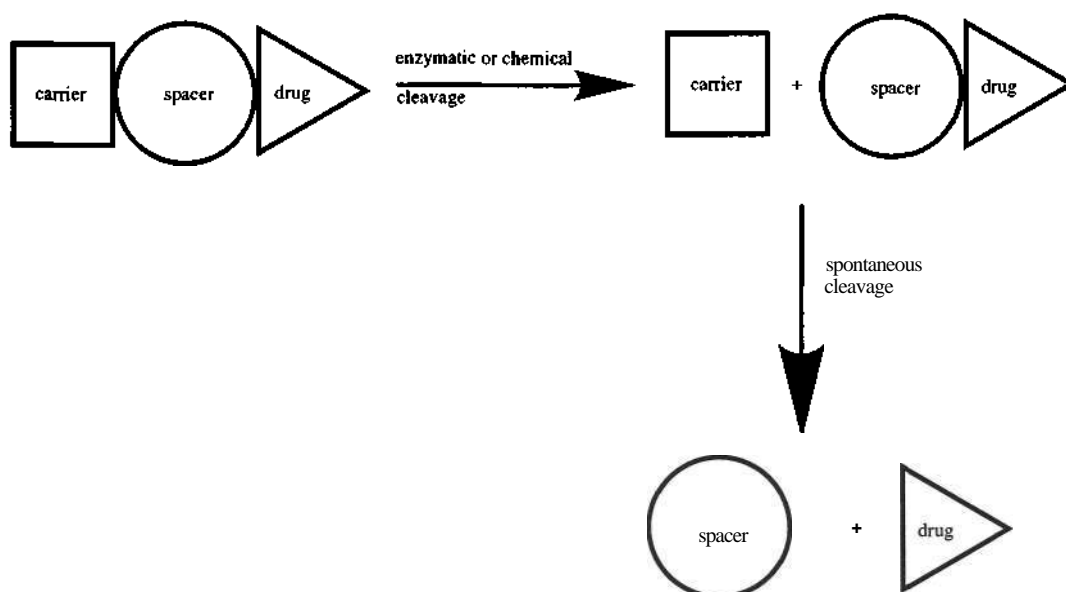

Figure 1. **Tripartate Prodrug**

### **Tripartate Prodrug Approach Applied to Phosphotriester**

#### **Bis-POM and POC Pronucleotides**

The approach of using a double ester as a prodrug was first used to improve the bioavailability of marketed  $\beta$ -lactam antibiotics and non-steroidal anti-inflammatory agents (2). In this approach, the diester undergoes enzymatic cleavage, releasing the unstable hydroxyalkyl ester which spontaneously disengages releasing the parent compound (Figure 2). The bulkiness



compound in the plasma (Scheme 1). Preliminary *in vitro* studies showed that bis-POM-PMEA provided a 100-fold intracellular increase of PMEAs (7). *In vitro* studies also showed that bis-pivaloyloxymethyl-PMEA (bis-POM-PMEA) had comparable activity to that of PMEAs against human immunodeficiency virus type 1 (HIV-1) infected CEM cells and human cytomegalovirus (HCMV) infected MRC-5 cells. Bis-POM-PMEA was substantially more potent than PMEAs against herpes simplex virus (HSV) types 1 and 2 infected Vero cells. Its persistence of HSV-2 inhibition, 20 times longer than that of the parent compound, correlates well with the reported enhanced cellular uptake (13). Bis-POM-PMEA also effected the growth of CEM cells. This inhibition is mostly cytostatic, rather than cytotoxic. At 0.4  $\mu\text{M}$ , the prodrug severely retarded the growth rate. Surprisingly, the growth of CEM cells was completely suppressed at 2  $\mu\text{M}$  concentration of bis-POM-PMEA, which may result from the liberation of two equivalents of formaldehyde and pivalic acid (Figure 3). Furthermore, *in vivo* bis-POM-PMEA demonstrated a 2-fold and 5-fold enhancement in bioavailability in rats (14) and monkeys (7), respectively. At a single 500 mg dose of bis-(POM)-PMEA, oral bioavailability was greater than 40% in clinical trials involving well fed subjects (14).

The synthesis of bis-POM-PMEA was carried out by reacting PMEAs with chloromethylpivalate in the presence of the bulky base *N,N'*-dicyclohexyl-morpholine carboxamide in 32% yield (Scheme 1). Bis-POM-PMEA has also been synthesized in lower yields by condensing various salts of PMEAs with either chloromethyl pivalate or iodomethyl pivalate (15).

Bis-(isopropylloxycarbonyloxymethyl) (bis-POC) pronucleotides are a modification of the bis-POM pronucleotides designed to reduce the cytostatic effect which may be caused by the release of pivalic acid (Scheme 2). Bis-POC pronucleotides are composed of a carbonate diester that undergoes esterase-catalyzed cleavage of the isopropyl ester to yield two equivalents of 2-propanol and formaldehyde (Figure 3). The bis-POC approach was applied to the anti-HIV agent (*R*)-9-(2-phosphono-methoxypropyl)adenine PMPA (16,17). PMPA was reported to completely prevent simian immunodeficiency virus (SIV) infection in monkeys even as late as 24 h after inoculation occurred (18). PMPA showed efficacy without significant toxicity in long-term treatment (13 months) of SIV-infected newborn monkeys (19). Furthermore, PMPA exhibited an effect against chronic SIV infection in monkeys (20). PMPA was also found to be

active against acute and chronic feline immunodeficiency virus (FIV) infections in cats (21). In phase I/II clinical trials, PMPA exhibited a 1.1 log reduction in HIV RNA levels after administration of only eight doses (22). Nevertheless, PMPA displayed low bioavailability in animals.

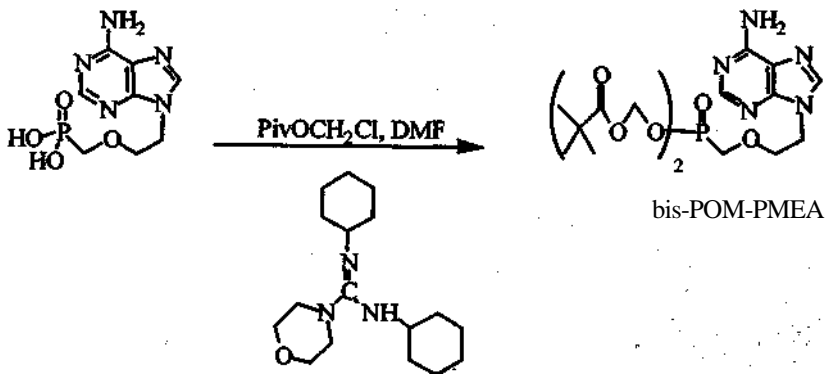

Scheme 1. Synthesis of bis-POM-PMEA

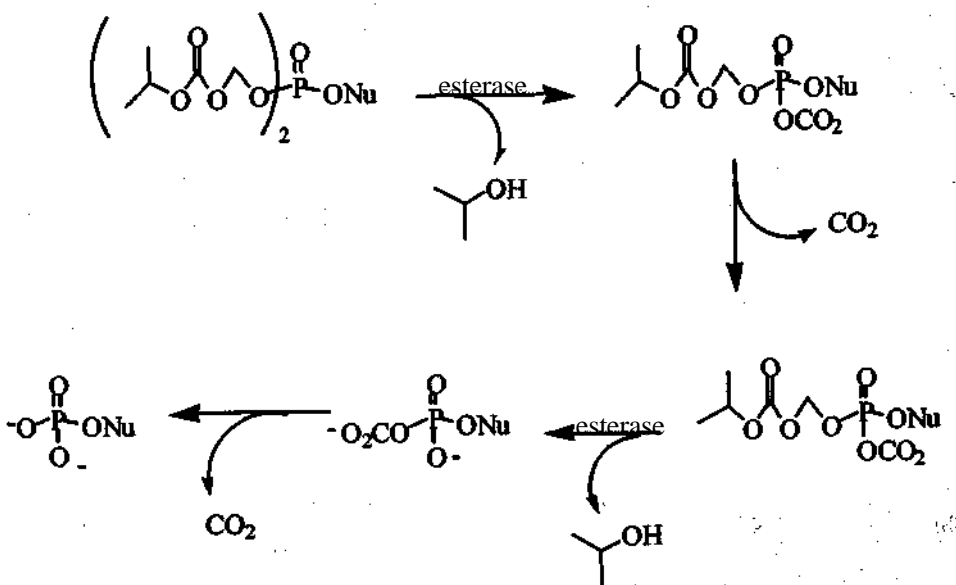
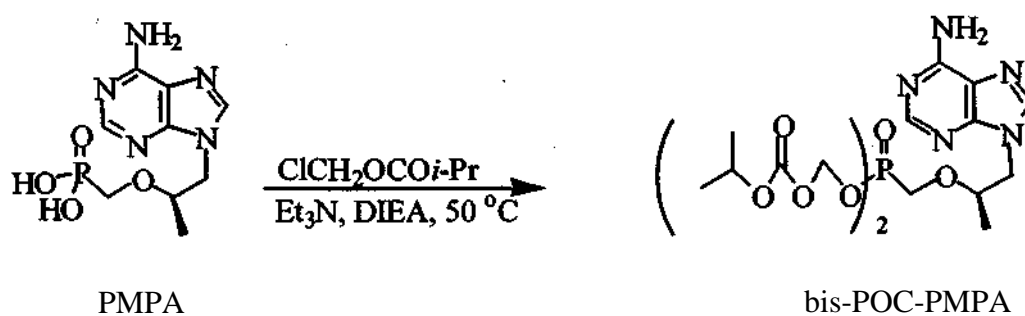

Figure 3. Decomposition of bis-POC pronucleotides

In an effort to improve the oral absorption of PMPA, Arimilli *et al.* (22) synthesized various acyloxyalkyl esters of PMPA. The most promising was the bis-isopropylloxycarbonyloxymethyl ester derivative (bis-POC), based upon its stability ( $t_{1/2} >150$  and 8, 20.5 h at pH 2.2 and 7.4, plasma, respectively), log P (1.3), efficacy, and low toxicity (23). *In vitro* studies of the metabolism of radiolabeled PMPA showed that it was hydrolyzed to PMPA and subsequently underwent phosphorylation to the mono and diphosphate derivatives (24). In addition, bis-POC-PMPA showed an oral bioavailability of 30% in dogs with minimal toxicity in repeated 5-day dosing of 60 mg/kg/day (25).

In the synthesis of bis-POC-PMPA, isopropylchloromethyl carbonate (24) was synthesized by adding pyridine to a cold ethereal solution of chloromethyl chloroformate and 2-propanol. The carbonate was then reacted with PMPA in dimethylformamide (DMF) in the presence of triethylamine (TEA) or diisopropylethylamine (DIPEA) at 50 °C for 20 h (Scheme 2).



Scheme 2. Synthesis of bis-POC-PMPA

### Bis-SDTE and SATE Pronucleotides

In an effort to improve the pharmacokinetics of some nucleotides, Imbach *et al.* (25,26) designed enzymatically activated pronucleotides, bis-[5-(2-hydroxyethylsulfidyl)-2-thioethyl]- (bis-SDTE) and bis-[S-acyl-2-thioethyl] (bis-SATE). The Bis-SDTE concept was designed to

take advantage of the concentration of reductase within the cytosol to liberate the nucleotide (Figure 4). The thioethyl phosphotriester, formed after reductive cleavage of the disulfide bond, spontaneously decomposes to the phosphodiester releasing episulfide. The phosphodiester then undergoes an identical sequence of enzymatic activation steps to yield the nucleotide. Both bis-SDTE triesters of 2', 3'-dideoxy-2',3'-didehydrouridine monophosphate (d4UMP) and 3'-azido-2',3'-dideoxythymidine monophosphate (AZTMP) were found to be cleaved in cell extracts 30-fold faster than in culture medium (26). The bis-SDTE concept failed to improve the antitumor efficacy of 5-fluoro-2',3'-dideoxyuridine (5-FdU) (27) while bis-SDTE-PMEA (28) exhibited enhanced antiviral activity. Limited success of the bis-SDTE approach is due to chemical instability as well as metabolism in serum.

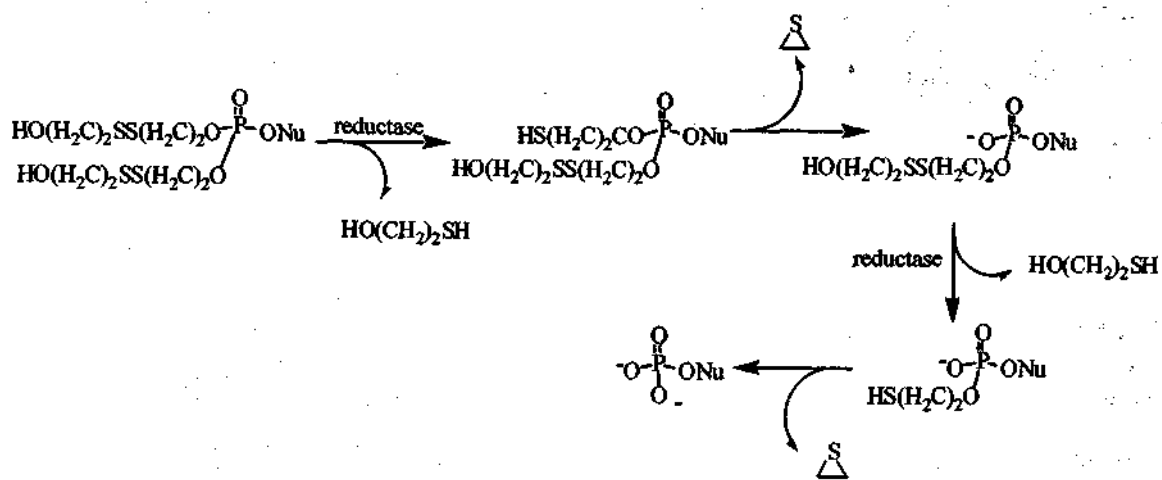

**Figure 4.** Decomposition of bis-SDTE pronucleotides

The bis-SATE concept, similar to the bis-POM approach, requires esterase-mediated activation to aid in nucleotide delivery (Figure 5) (29).

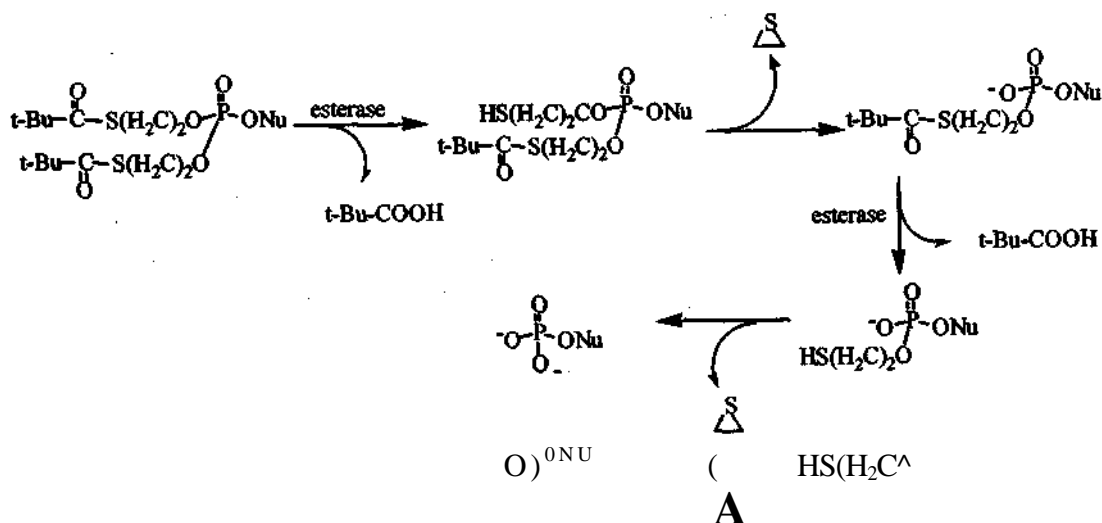

**Figure 5.** Decomposition of bis-SATE pronucleotides

The esterase cleaves the thioester to form the thioethyl phosphonate triester that spontaneously decomposes to episulfide and the phosphonate diester, which undergoes the same sequence of enzymatic activation ultimately releasing two equivalents of episulfide. It has been shown that the addition of SDTE and SATE moieties cause cytotoxicities comparable to that of the parent nucleosides in human bone marrow cells (30).

Among the various bis-SATE side chains synthesized, bis-*t*-buSATE-AZTMP was the most stable in culture medium and cell extract (27). Its stability was mostly due to the bulkiness of *t*-butyl residue, which prevents rapid cleavage. The stability of *t*-buSATE moiety was also demonstrated in the case of the *t*-buSATE derivative of 2',3'-dideoxy-3'-oxoadenosine (isoddA) (31). The bis-SATE concept has been proven to be successful in the cases of 2',3'-didehydro-2',3'-dideoxythymidine monophosphate (d4TMP) (32), AZTMP (29) and 2',3'-didehydro-2',3'-dideoxyadenosine monophosphate (d4AMP) (33), which were active against HIV infected TK-CEM cells (thymidine kinase negative CEM cells). In addition to enhanced activity, the prodrug of d4A was more stable than d4A itself against acid catalyzed depurination (34). For many bis-SATE pronucleotides, there was a decrease in activity against HIV infected TK-CEM cells.



Thioesters of bis-SATE pronucleotides of d4T were synthesized by reaction of thiocarboxylic acids with 2-iodoethanol, followed by condensation with *N,N*-diisopropylphosphorodichloridite in tetrahydrofuran in the presence of triethylamine to yield the corresponding phosphoramidites. These were coupled with d4T in the presence of 1*H*-tetrazole and oxidized *in situ* with 3-chloroperoxybenzoic acid to obtain the bis-SATE phosphotriester (Scheme 3).

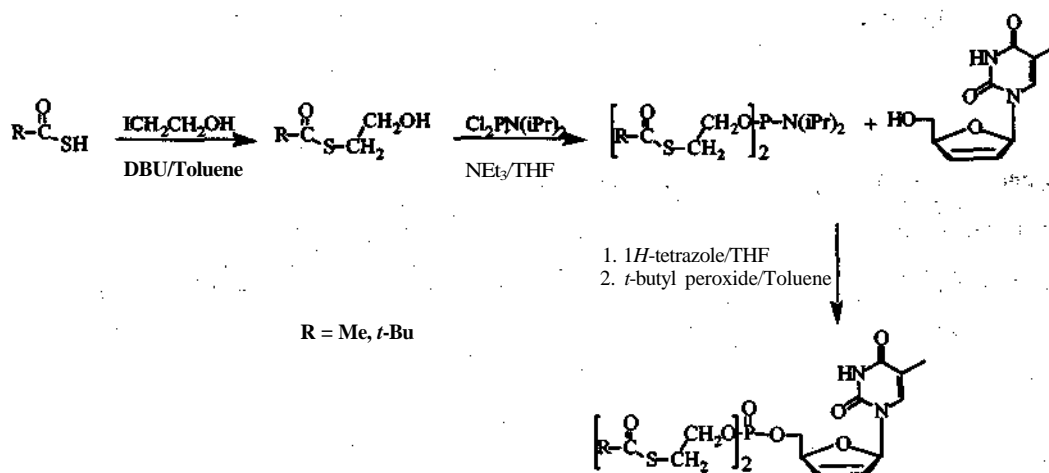

**Scheme 3.** Synthesis of SATE derivatives of d4TMP

For the synthesis of the bis-DTE phosphotriester of 2',3'-dideoxyuridine (ddU) (35), dithiodiethanol phosphodiester was synthesized by protecting dithiodiethanol with monomethoxytrityl chloride in the presence of diisopropylethanolamine followed by phosphorylation using phosphoryloxy chloride, imidazole and triethylamine. The dithiodiethanol phosphodiester was condensed with ddU in triethylamine in the presence of 1-mesitylene-2-sulfonyl-3-nitro-1,2,4-triazole. Following treatment with acetic acid and aqueous methanol gave bis-DTE ddU (Scheme 4).

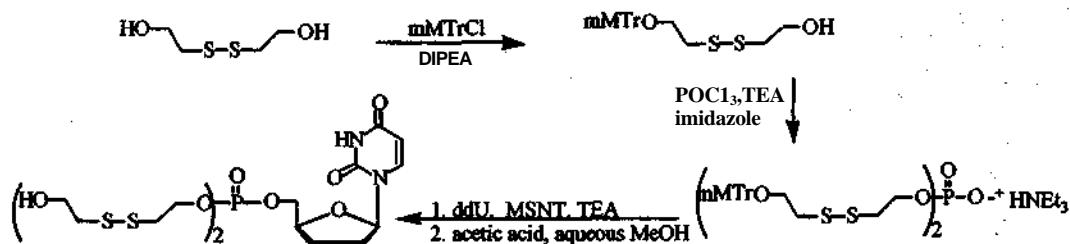

**Scheme 4.** Synthesis of DTE pronucleotides of ddU

### Bis-Acyloxybenzyl Pronucleotides

Bis(4-acyloxybenzyl) pronucleotides were designed by Freeman *et al.* (36) and Glazier *et al.* (37) to avoid the close proximity of the negative charge of the intermediate mono-protected phosphodiester and the cleaving site of the carboxyesterase, so as to ease the cleavage of the remaining masking group. Furthermore, Freeman *et al.* (38, 39) calculated the necessary distance for avoidance of this intramolecular electronic repulsion between negative charge of the phosphodiester and carboxyester group to be approximately 4 Å in distance (Figure 6). The process of nucleotide delivery involves first the cleavage at the 4-position of the aromatic ring to yield 4-hydroxybenzyl phosphotriester that spontaneously decomposes to form the phosphodiester. The phosphodiester undergoes the same process again to yield the nucleotide.

Freeman *et al.* (36) applied this approach for the delivery of AZTMP and found that the prodrug activity against HIV-1 and SIV was comparable to that of AZT *in vitro*. The prodrug ability to deliver AZTMP intracellularly was not determined. Glazier *et al.* (40) demonstrated that bis(4-acyloxybenzyl) was susceptible to enzymatic cleavage in the case of acyclovir.

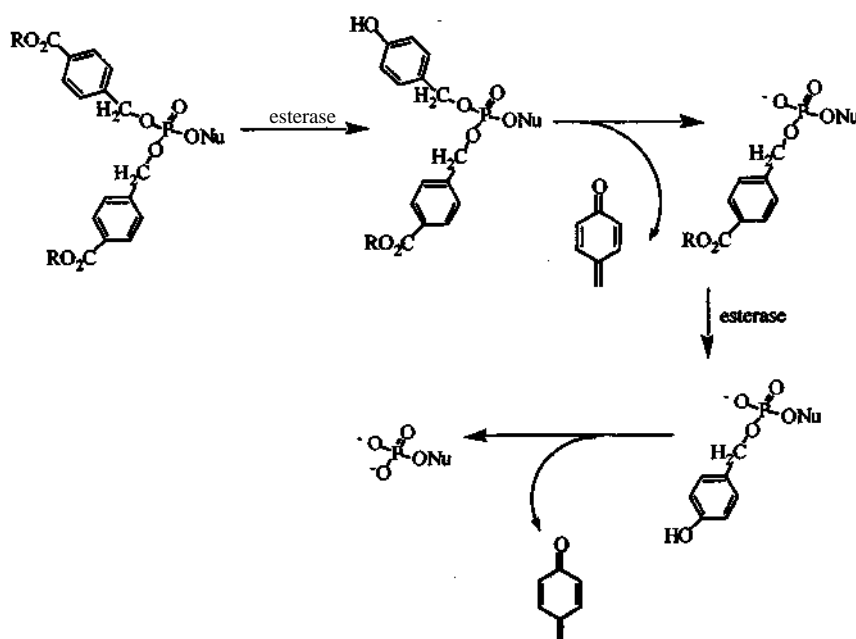

**Figure 6.** Proposed decomposition of acyloxybenzyl phosphotriesters

monophosphate in the presence of porcine liver esterase. Like with DTE pronucleotides, the bis-acyloxybenzy approach is limited by very short half-lives of the prodrugs. In addition, these prodrugs are too lipophilic (log P values range from 1 to 4) for systemic administration (40). *In vivo*, the bis(4-acyloxybenzyl) derivatives of ACVMP exhibited no significant toxic side effects at concentrations up to 100 mg/kg of body weight (40).

In the synthesis of bis-acyloxybenzyl phosphotriester of AZT, the appropriate 4-acyloxybenzyl alcohol is reacted with *N,N*-diisopropylphosphorochloridate in the presence of triethylamine to yield the corresponding phosphodiester. The phosphodiester is coupled with the AZT in the presence of [*1H*]-tetrazole and oxidized *in situ* with *m*CPBA to obtain the phosphotriester (Scheme 5) (41).

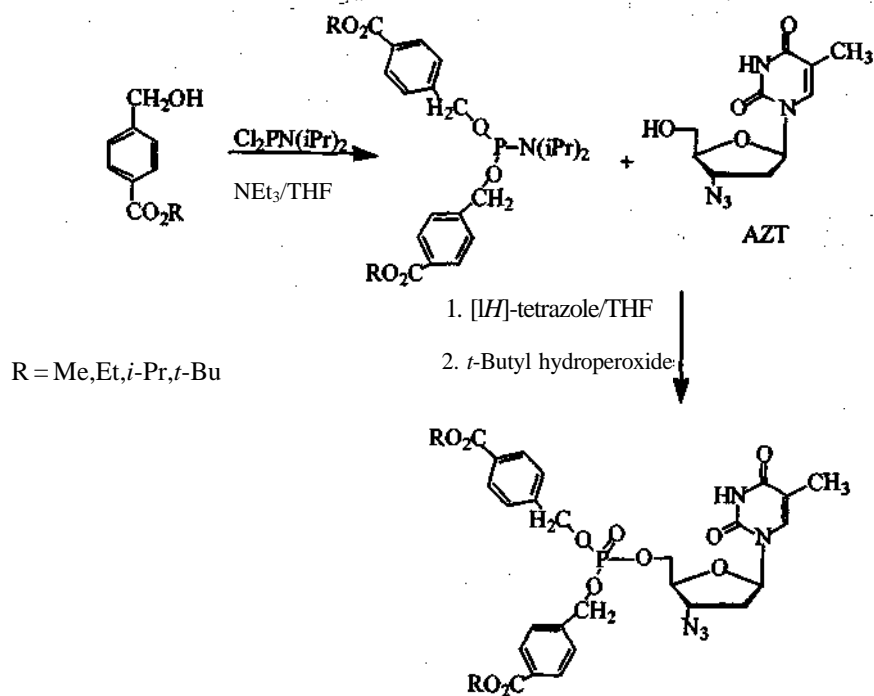

**Scheme 5.** Synthesis of bis-acyloxybenzyl-derivatives of AZT-MP

### CycloSal-Pronucleotides

The cycloSal-pronucleotide concept involves nucleotide delivery based upon pH-driven selective chemical hydrolysis (Figure 7) (42,43). The tandem cleavage originates with the hydrolysis of a phenyl ester followed by hydrolysis of a benzyl ester of the phosphotriester. This concept is based upon the principle that the selection of phenyl, benzyl and alkyl phosphate esters can influence the hydrolysis steps of the tripartate approach (44). The phenyl ester is cleaved initially because of stabilization caused by delocalization of the negative charge in the aromatic ring yielding the 2-hydroxybenzylphosphodiester. The sequence of hydrolytic steps has been verified by multinuclear NMR spectroscopy and mass spectrometry (45,46). This concept was applied to anti-HIV agents such as d4T (44,46), 5-Furd (45), AZT (47,48), 2',3'-dideoxyadenosine (ddA) (49, 50), d4A (50) and 2'-fluoro-2',3'-dideoxyadenosines (F-ara-ddA and F-ribo-ddA)(51).

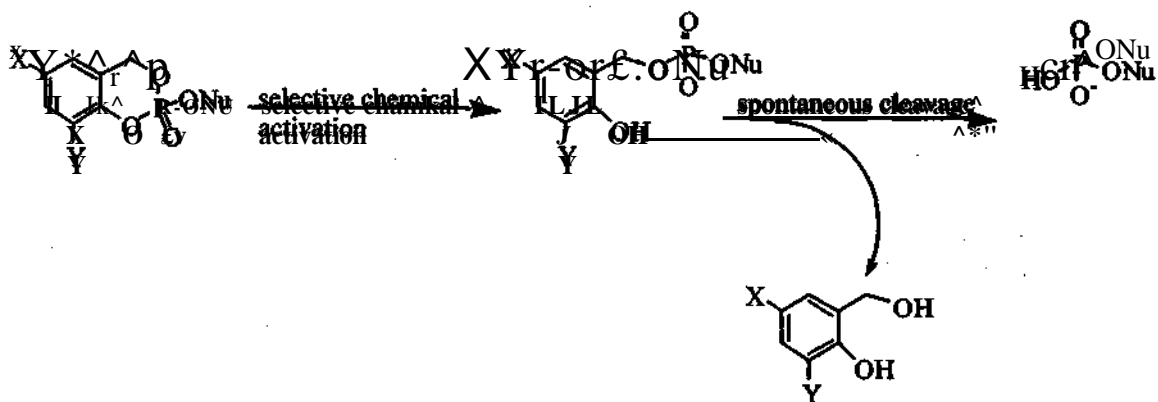
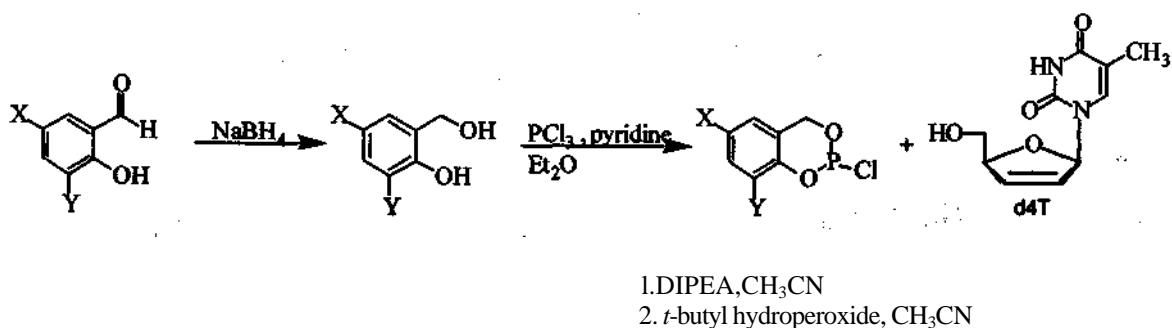

**Figure 7.** Proposed decomposition of cycloSal-pronucleotides

CycloSal-Pronucleotides have been successfully used to deliver mono-phosphates of d4T, ddA, F-ara-ddA and F-ribo-ddA. *In vitro* studies of cycloSal-nucleotides of d4T showed that 3-,5-methyl and 3, 5-dimethyl-cycloSal-d4TMPs had more potent anti-HIV activity than the parent compound (44).

More importantly, the potency of cycloSal-d4TMPs was maintained in thymidine kinase-deficient CEM (TKCEM) cells. The electron donating capacity of the ring substituent influenced the degree of biological activity with the stronger electron-donating group having the greatest potency. CycloSal-ddA was synthesized to circumvent deamination by adenosine deaminase (ADA) and adenosine monophosphate deaminase (AMPDA). Studies with ADA and AMPDA demonstrated that the cycloSal-triesters are not susceptible to enzymatic deamination (49) as reported earlier for 5'-O-protected adenosine (52). CycloSal-ddAMPs and cycloSal-d4AMP showed more potency than the respective parent compounds (49). In addition, this increase in potency was accompanied with a higher selectivity index than the parent compounds. CycloSal-derivatives of F-ara-ddA and F-ribo-ddA were stable in the presence of ADA and AMPDA and more potent than the parent compounds (51).

In the synthesis of cycloSal-d4T monophosphates (44), salicyl alcohols were obtained by first reduction of salicylaldehydes or salicylic acids using sodium borohydride or lithium aluminum hydride in 75-90% yields. The salicyl alcohols were reacted with phosphorus trichloride to obtain the cyclic saligenylchlorophosphanes. These were condensed with d4T in the presence of diisopropylethylamine and subsequently oxidized *in situ* by *t*-butylhydroperoxide (TBHP) to obtain the corresponding phosphotriesters in 50-73% yield (Scheme 6).



X = OMe, Y = H; X = Y = Me; X = Me, Y = H; X = H, Y = Me  
X = H, Y = OMe; X = Nitro, Y = H

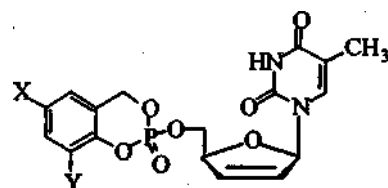

Scheme 6. Synthesis of cycloSal-d4TMP

### Phosphoramidate and Cyclic Phosphoroamidate Pronucleotides

McGuigan *et al.* (53) designed and synthesized phosphoramidate pronucleotides as a mean of circumventing the membrane impermeability of negatively charged nucleotides (Scheme 7). Phosphoramidate derivatives of d4TMP (54-57), 2', 3'-dideoxy-3'-thiacytidine monophosphate (3TCMP) (58), AZTMP (59), (ddAMP) (60) and d4AMP (60,61) have been synthesized in an effort to enhance the delivery of their corresponding monophosphate. Delivery of the nucleotide analogue involves degradation of the prodrug by the liberation of the phenyl group or cleavage of the methyl ester, which ultimately leads to complete unmasking mediated by enzyme or chemical catalysis (Figure 8).

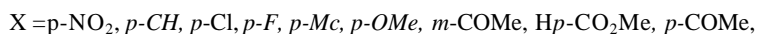
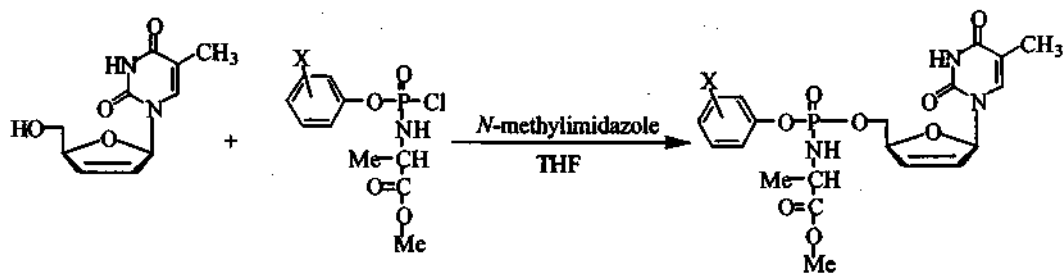

**Scheme 7.** Synthesis of phosphoramidate derivatives of d4T

*In vitro* studies of d4T phosphoramidate showed that the prodrug was potent against HIV-2 infected CEM and TK CEM cells, which supports evidence of efficient intracellular delivery of nucleotide (62). The prodrug of d4T was reported to be active against other retroviruses such as SIV, FIV, Visna Virus and Moloney murine sarcoma virus *in vitro* (63). Among various β-amino acid derivatives synthesized, the L-alanine provided the most efficacy as an anti-viral agent (63), while its enantiomer was 30 times less potent. *In vitro* studies indicated that phosphoramidates of 3TC and AZT provided no benefit as inhibitors of HIV replication (58, 59). In the case of ddA and d4A, the potency of the phosphoramidate prodrugs increased significantly (60). In addition, these phosphoramidates displayed anti-HBV activity equal in

potency to that of 3TC. Both aryloxyphosphoramidate prodrugs displayed a higher selectivity index in comparison with the parent compounds.

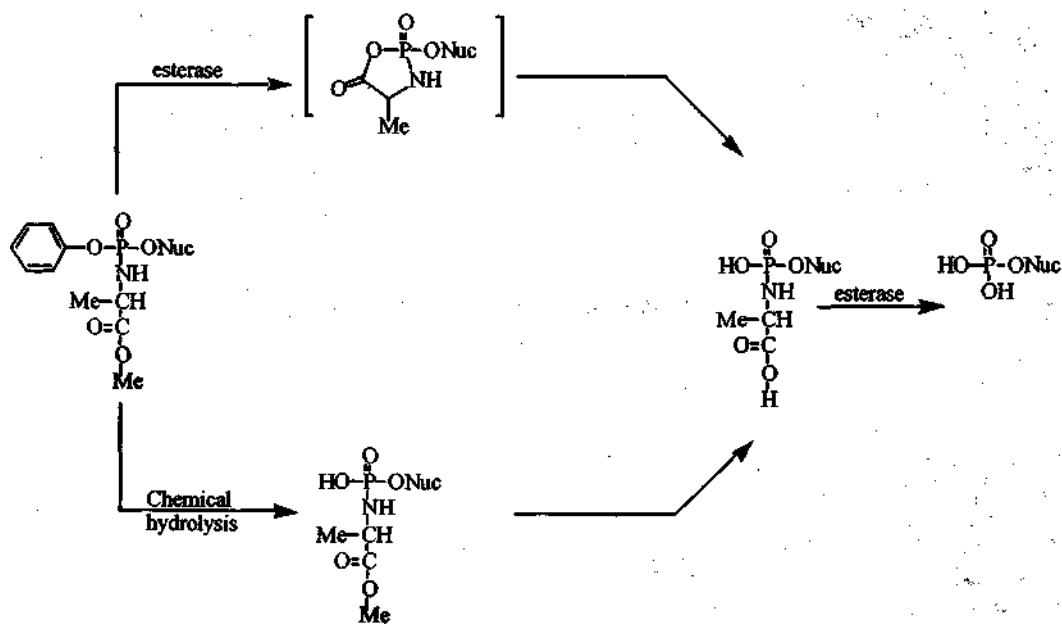

**Figure 8.** Decomposition of phosphoramidates

Five and six membered cyclic phosphoramidate derivatives were also used to aid in the delivery of nucleotide analogs (Figure 9). Jones *et al.* (64) found that 5'-O-3"-methyl-1", 3", 2"-oxazaphosphacyclopentan-2"-yl-thymidine 2"-oxide and other five membered cyclic phosphotriesters were very unstable at physiological pH. De Clerq *et al.* (65) synthesized 5'-O-3"-methyl-1",3",2"-oxazaphosphacyclopentan-2"-yl derivatives of acyclovir and (*E*)-5-(2-bromovinyl)-2'-deoxyuridine (BVDU) after finding that their hydrolysis rate may be dependent upon the buffer used (Scheme 8). The phosphoramidates of 5-fluoro BVDU were synthesized by Meyers *et al.* (66) and found to be inactive against TK" HSV-1 replication in rabbit kidney cells indicating no release of BVDU-monophosphate. Farquhar *et al.* (67) synthesized the more stable six membered cyclic phosphoramidate as means to delivery 5-FdUMP intracellularly (Scheme 9). Both prodrugs were resistant to enzymatic degradation by 5'-nucleotidase, alkaline phosphatase, venom phosphodiesterase and crude snake venom. The dioxaphosphorinanyl derivative of 5-FdUrd (X = O) showed virtually no activity in the mice model study.

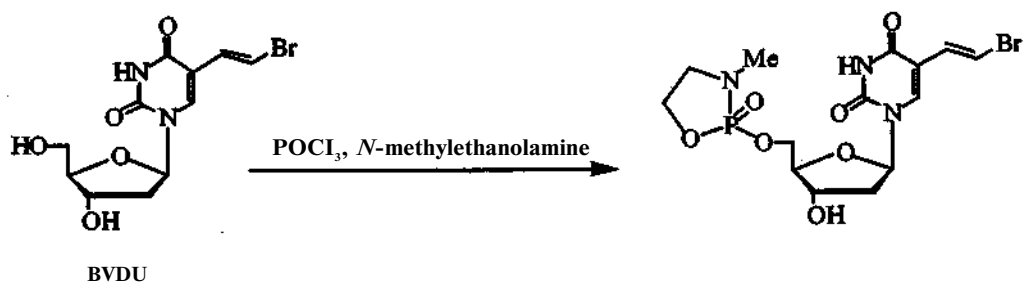
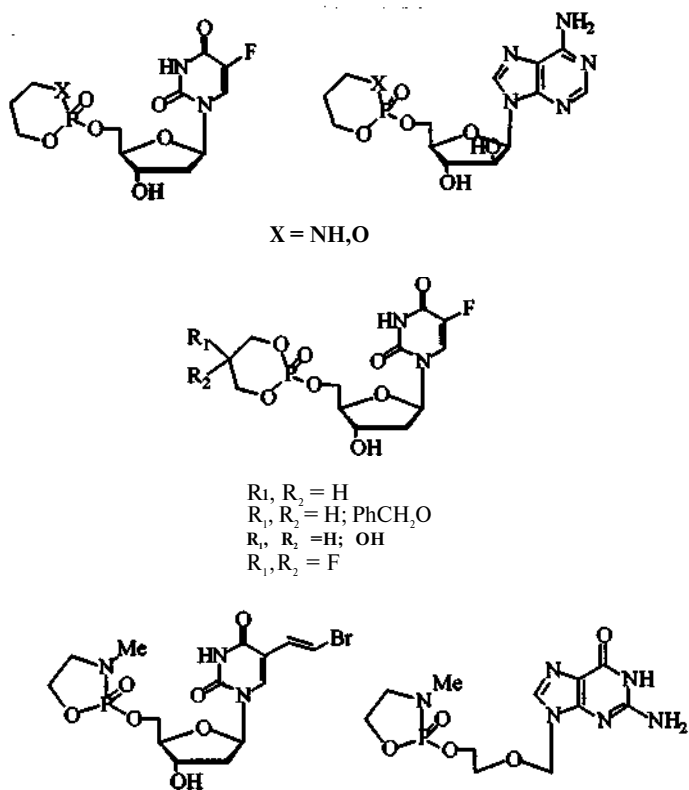
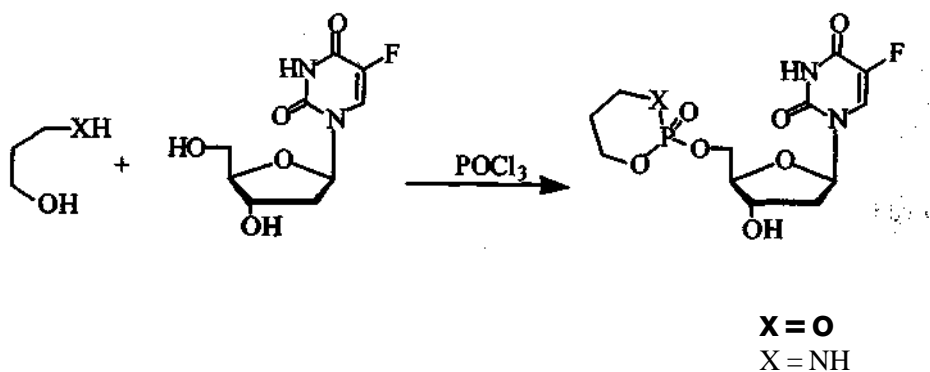

Figure 9. Oxazaphosphacyclic and dioxophosphacyclic nucleoside derivatives



Scheme 8. Synthesis of oxaphosphacyclopentanyl derivative of BVDU





**Scheme 9.** Synthesis of oxaza- and dioxaphosphacyclohexyl derivatives of 5-Furd

## Conclusions

Consequently, tripartate prodrugs provide more potent compounds comparing with bipartate prodrugs. Since tripartate prodrugs overcome the stability of the linkage between carrier and drug. But it is obvious that both prodrugs need further investigation to explain details of mechanism and get more potent prodrugs. These recent findings suggest us that it is inevitable to find new approach to design prodrugs as anti-viral and anti-cancer compounds.

## REFERENCES

1. Carl, P.L., Chakravarty, P.K., Katzenellenbogen, J.A. "A Novel Connector Linkage Applicable in Prodrug Design" *J. Med. Chem.*, 24,480-481 (1981).
2. Roche, E.B. "Design of Biopharmaceutical Properties through Prodrugs and Analogs" *Academy of Pharmaceutical Sciences Symposium*, Washington DC (1977).
3. Sastry, J.K., Nehete, P.N., Khan, S., Nowak, B J., Plunkett, W., Arlinghaus, R.B., Farquhar, D. "Membrane-Permeable Dideoxyuridine 5'-Monophosphate Analogue Inhibits Human Immunodeficiency Virus Infection" *Mol. Pharmacol.*, 41,441-445 (1992).
4. Pompon, A., Lefebvre, I., Imbach, J.-L., Khan, S., Farquhar, D. "Pharmacokinetics of AZTMP for intracellular delivery of zidovudine monophosphate, in mice" *Antiviral Chem. Chemother.*, 5,91-98 (1994).
5. Farquhar, D., Khan, S., Srivastva, D.N., Saunders, P.P. "Synthesis and Antitumor Evaluation of Bis[(Pivaloyloxy)methyl]-2'-Deoxy-5-Fluorouridine 5'-Monophosphate

- (FdUMP): A Strategy to Introduce Nucleotides into Cells" *J. Med. Chem.*, 37, 3902-3909 (1994).
6. **Srinivas, R.V., Robbins, B.L., Connelly, M.C., Gong, Y.-F., Bischofberger, N., Fridland, A.** "Metabolism and *In Vitro* Antiretroviral Activities of Bis(Pivaloyloxymethyl) Prodrugs of Acyclic Nucleoside Phosphonates" *Antimicrob. Agents Chemother.*, 37, 2247-2250 (1993).
  7. **Nassens, L., Balazarini, J., De Clerq, E.** "Therapeutic potential of PMEAs as antiviral drug" *Med. Virol.*, 4, 147-159 (1994).
  8. **De Clerq, E.** "Broad-spectrum anti-DNA virus and anti-retrovirus activity of phosphonylmethoxyalkylpurine and pyrimidines" *Biochem. Pharmacol.*, 42, 963-972 (1991).
  9. **Walker, R.E., Vogel, S.E., Jaffe, H.S., Polis, M. A., Kovacs, J., Markowitz, N., Masur, H., Lane, H.C.** "A Phase I/II Study of PMEA in HIV Infected Patients" Abstracts of Papers; *V National Conference on Human Retroviruses and Related Infections*, Washington DC (1993).
  10. **Balzarini, J., Naesens, L., Slachmuylders, J., Niphuis, H., Rosenburg, I., Holy, A., Schellekens, H., De Clerq, E.** "9-(2-Phosphonylmethoxyethyl)adenine (PMEA) Effectively Inhibits Retrovirus Replication *In Vitro* and Simian Immunodeficiency Virus Infection in Rhesus Monkeys" *AIDS*, 5, 21-28 (1991).
  11. **Starrett, J.E., Jr., Tortolani, D.R., Russel, J., Hitchcock, M.J.M., Whiterock, V., Martin, J. C., Mansuri, M.M.** "Synthesis, Oral Bioavailability Determination, and *In Vitro* Evaluation of Prodrugs of the Antiviral Agent 9-[2-(Phosphonomehtoxy)-ethyl]adenine (PMEA)" *J. Med. Chem.*, 37, 1857-1864 (1994).
  12. **Bronson, J. J., Ghazzouli, I., Hitchcock, M.J.M., Russel, J.W., Klunk, L.J., Kern E.R., Martin, J.C.** "*In vivo* Anti-retrovirus and Anti-cytomegalovirus Activity of 9-((2-Phosphonylmethoxy)-ethyl) adenine (PMEA)" Abstracts of Papers; *5<sup>th</sup> International Conference on AIDS*, Montreal, Canada, Abstract M.C.P. 74 (1989).
  13. **Starrett, J.E.Jr., Tortolani, D.R., Hitchcock, M.J.M., Martin, J.C., Mansuri, M.M.** "Synthesis and *In Vitro* Evaluation of a Phosphonate Prodrug: Bis(Pivaloyloxymethyl) 9-(2-Phosphonylmethoxyethyl)adenine" *Antiviral Res.*, 19, 267-273 (1992).

- 14. Jones, R.J., Arimilli, M.N., Lin, K.-Y., Louie, M.S., McGee, L.R., Shaw, J.-P., Burman, D., Lee, M., Kennedy, J.A., Pflisbe, E.J., Bischofberger, N., Lee, W. A., Cundy, K.C.** "Nucleotides and their biological Application" Abstract Op11; *XII International Roundtable Nucleosides*, September 15-19, La Jolla, USA (1996).
- 15. Srivastva, D., Farquhar, D.** "Bioreversible Phosphate Protective Groups: Synthesis and Stability of Model Acyloxymethyl Phosphates" *Bioorg. Chem.*, **12**,118-129 (1984).
- 16. Balzarini, J., Aquaro, S., Perno, C.-F., Witvrouw, M., Holy, A., De Clercq, E.** "Activity of the (*R*)-Enantiomers of 9-(2-Phosphonylmethoxypropyl)adenine and 9-(2-Phosphonylmethoxypropyl)-2,6-Diaminopurine Against Human Immunodeficiency Virus in Different Human Cell Systems" *Biochem. Biophys. Res. Comm.*, **219**,337-341 (1996).
- 17. Balzarini, J., Holy, A., Jindrich, J., Naesens, L., Snoeck, R., Schols, D., De Clercq E.** "Differential Antiherpesvirus and Antiretrovirus Effects of the (*S*) and (*R*) Enantiomers of Acyclic Nucleoside Phosphonates: Potent and Selective *In Vitro* and *In Vivo* Antiretrovirus Activities of (*R*)-9-(2-Phosphonylmethoxypropyl)-2,6-Diaminopurine" *Antimicrob. Agents and Chemother.*, **37**, 332-338 (1993).
- 18 .Tsai, C.C., Follis, K.E., Sabo, A., Beck, T.W., Grant, R.F., Bischofberger, N., Benveniste, R.E., Black, R.** "Prevention of SIV Infection in Macaques by (*R*)-9-(2-Phosphonylmethoxypropyl)adenine" *Science*, **270**, 1197-1199(1995).
- 19. Van Rompay, K.K.A., Cherrington, J.M., Marthas, M.L., Berardi, C J., Mulato, A.S., Spinner, A., Tarara, R.P., Canfield, D.R., Telm, S., Bischofberger, N., Pederson, N.C.** "9-[2-(Phosphomethoxy)propyl]-adenine Therapy of Established Simian Immunodeficiency Virus Infection in Infant Rhesus Macaques" *Antimicrob. Agents Chemother.*, **40**, 2586-2591 (1996).
- 20. Tsai, C.C., Follis, K.E., Beck, T.W., Sabo, A., Bischofberger, N., Dailey, P.J.** "Effects of (*R*)-9-(2-Phosphonylmethoxypropyl)adenine Monotherapy on Chronic SIV Infection in Macaques" *AIDS Research and Human Retroviruses*, **13**, 707-712 (1997).
- 21 Myles, M.H., Bischofberger, N., Hoover, E.A.** "Evaluation of 9(2-Phosphonylmethoxypropyl)adenine Antiviral Therapy for Acute Feline Immunodeficiency Virus Infection in Cats" *3<sup>rd</sup> International Feline Retrovirus Research Symposium*, Fort Collins, Col. USA (1996).

22. Arimilli, M.N., Kim, C.U., Dougherty, J., Mulato, A., Oliyai, R., Shaw, J.P., Cundy, K.C., Bischofberger, N. "Synthesis, *In Vitro* Biological Evaluation and Oral Bioavailability of 9-[2-(Phosphonomethoxy)propyl]adenine (PMPA) Prodrugs" *Antiviral Chem. Chemother.*, 8,557-564 (1997).
23. Fridland, A., Robbins, B. L., Srinivas, R. V., Arimilli, M., Kim, C, Bischofberger, N. "Antiretroviral Activity and Metabolism of bis(POC)PMPA, an Oral Bioavailable Prodrug of PMPA" *Antiviral Res.*, 34, A49,27 (1997).
24. Bohme, H., Budde, J. "Chloromethyl-, Mercaptomethyl-and Imidomethyl-carbonate" *Synthesis*, 588-590 (1971).
25. Perigaud, C, Gosselin, G., Imbach, J.-L. "Minireview: from the Pronucleotide Concept to the SATE Phosphate Protecting Groups" *Curr. Topics in Med. Chem.*, 2, 15-29 (1997).
26. Peuch, F., Gosselin, G., Lefebvre, I., Pompon, A., Aubertin, A.-M., Kirn, A., Imbach, J.-L. "Intracellular Delivery of Nucleoside Monophosphates Through a Reductase-Mediated Activation Process" *Antiviral Res.*, 22,155-174 (1993).
27. Giradet, J.-L., Gosselin, G., Périgaud, C., Balzarini, J., De Clercq, E., Imbach, J.-L. *Nucleosides and Nucleotides*, 14,645-647 (1995).
28. Benzaria, S., Pélicano, H., Johnson, R., Maury, G., Imbach, J.-L., Aubertin, A.-M., Obert, G., Gosselin, G. "Synthesis, *In Vitro* Antiviral Evaluation, and Stability Studies of Bis(5-acyl-2-thioethyl) Ester Derivatives of 9-[2-(Phosphonomethoxy)ethyl]adenine (PMEA) as Potential PMEA Prodrugs with Improved Oral Bioavailability" *J. Med. Chem.*, 39,4958-4965(1996).
29. Lefebvre, L, Perigaud, C, Pompon, A., Aubertin, A.-M., Girardet, J.-L., Kirn, A., Gosselin, G., Imbach, J.-L. "Mononucleoside Phosphotriester Deravitives with S-Acyl-2-thioethyl Bioreversible Phosphate-Protecting Groups: Intracellular Delivery of 3'-Azido-2',3'-dideoxythymidine 5'-Monophosphate" *J. Med. Chem.*, 38,3941-3950 (1995).
30. Perigaud, C, Girardet, J.-L., Lefebvre, I., Xie, M.-Y., Aubertin, A.-M., Kirn, A., Gosselin, G., Imbach, J.-L., Sommadossi, J.-P. "Comparison of Cytotoxicity of Mononucleoside Phosphotriester Derivatives Bearing Biolabile Phosphate Protecting

Groups in Normal Human Bone Marrow Progenitor Cells" *Antiviral Chem. Chemother.*, 7, 338-345 (1996).

- 31. Valette, G., Pompon, A., Giradet, J.-L., Gosselin, G., Perigaud, C, Gosselin, G., Imbach, J.-L.** "Decomposition Pathways and in vitro HIV Inhibitory Effects of Isodda Pronucleotides: Toward a Rational Approach for Intracellular Delivery of Nucleoside 5'-Monophosphates" *J. Med. Chem.*, 39,1981-1990 (1996).
- 32. Girardet, J.-L., Perigaud, C, Aubertin, A.-M., Gosselin, G., Kirn, A., Imbach, J.-L.** *Bioorg. Med. Chem. Lett.*, 5,2981-2984 (1995).
- 33. Perigaud, C, Gosselin, G., Benzaria, S., Girardet, J.-L., Maury, G., Pelicano, H., Aubertin, A.-M., Kirn, A., Imbach, J.-L.** "Bis(S-Acyl-2Thioethyl)esters of 2',3'-Dideoxyadenosine 5'-Monophosphate are Potent Anti-HIV Agents in Cell Culture" *Nucleosides and Nucleotides.*, 14,789-791 (1995).
- 34. Perigaud, C, Aubertin, A.-M., Benzaria, S., Pelicano, H., Girardet, J.-L., Maury, G., Gosselin, G., Kirn, A., Imbach, J.-L.** "Equal Inhibition of the Replication of Human Immunodeficiency Virus in Human T-Cell Culture by ddA Bis (SATE) Phosphotriester and 3'-Azido-2',3'-dideoxythymidine" *Biochem. Pharmacol.*, 48,11-14 (1994).
- 35. Périgaud, C, Gosselin, G., Lefebvre, I., Girardet, J.-L., Benzaria, S., Barber, I., Imbach, J.-L.** "Rational Design for Cytosolic Delivery of Nucleoside Monophosphates: "SATE" and "DTE" as Enzyme-Labile Transient Phosphate Protecting Groups" *Bioorg. Med. Chem. Lett.*, 3,2521-2526 (1993).
- 36. Routledge, A., Walker, L, Freeman, S., Hay, A., Mahmood, N.** "Synthesis, Bioactivation and Anti-HIV Activity of 4-Acyloxybenzyl, Bis(Nucleosidyl-5'-yl) Phosphates" *Nucleosides and Nucleotides*, 14,1545-1558 (1995).
- 37. Glazier, A., Kwong, C, Rose, J., Buckheit, R.** *Antiviral Res.*, 17, (Suppl. 1) 66 (1992).
- 38. Thomson, W., Nicholls, D., Mitchell, A.G., Corner, J.A., Irwin, W J., Freeman, S.** "Synthesis and Bioactivation of Bis(aryloxymethyl) and mono(aryloxymethyl) Esters of Benzylphosphonate and Phosphonoacetate" *J. Chem. Soc. Perkin Trans.*, 1, 2303-2308 (1993).

- 39. Mitchell, A.G., Thomson, W., Nicholls, D., Irwin, W.J., Freeman, S.** "Prodrugs of Phosphonoformate: The Effect of Para-Substituents on the Products, Kinetics and Mechanism of Hydrolysis of Dibenzylmethoxycarbonyl Phosphonate" /. *Chem. Soc. Perkin Trans.*, 2,1145-1150(1992).
- 40. Glazier, A., Yanachkova, M., Yanachkov, I., Wright, G.E., Kern, E.R., Sidwell, R., Smee, D., McKeough, M., Sprunance, S.L.** *9<sup>th</sup> International Conference on Antiviral Research*, May 19-24, Japan (1996).
- 41. Thomson, W., Nicholls, D., Irwin, W J., Al-Mushadani, J.S., Freeman, S., Karpas, A., Petrik, J., Mahmood, N., Hay, A.J.** "Synthesis, Bioactivation and Anti-HIV Activity of the Bis(4-Acyloxybenzyl) and Mono(4-Acyloxybenzyl) Esters of the 5'-Monophosphate of AZT" *J. Chem. Soc. Perkin Trans.*, 1, 1239-1245 (1993).
- 42. Meier, C.** "4H-1.3.2.-Benzodioxaphosphorin-2-nucleosyl-2-oxide A New Concept for Lipophilic, Potential Prodrugs of Biologically Active Nucleoside Monophosphates" *Angew. Chem.*, **108**, 77-79 (1996).
- 43. Meier, C, Knispel, T., Lorey, M., Balzarini, J.** "CycloSal-Pronucleotides: The Design and Biological Evaluation of a New Class of Lipophilic Nucleotide Prodrugs" *Int. Antiviral News*, 5,183-186 (1997).
- 44. Meier, C, Lorey, M., De Clerq, E., Balzarini, J.** "Cyclic Saligenyl Phosphotriesters of 2',3'-Dideoxy-2',3'-didehydrothymidine (d4T)-A New Pro-nucleotide Approach" *Bioorg. Med. Chem. Lett.*, 7,99-104 (1997).
- 45. Lorey, M., Meier, C, De Clerq, E., Balzarini, J.** "New Synthesis and Antitumor Activity of CycloSal-Derivatives of 5-Fluoro-2'-deoxyuridinemonophosphate" *Nucleosides and Nucleotides*, 16,789-792 (1997).
- 46. Meier, C, Lorey, M., De Clerq, E., Balzarini, J.** "CycloSal-2',3-dideoxy-2',3-didehydrothymidine Monophosphate (CycloSal-d4TMP): Synthesis and Antiviral Evaluation of a New d4TMP Delivery System" *J. Med. Chem.*, 41,1417-1427 (1998).
- 47. Meier, C, De Clerq, E., Balzarini, J.** "Cyclo-Saligenyl-3'-azido-2',3'-dideoxythymidine monophosphate (CycloSal-AZTMP) A New Pro-nucleotide Approach" *Nucleosides and Nucleotides*, 16,793-796 (1997).

- 48.Meier, C, De Clercq, E., Balzarini, J.** "Nucleotide Delivery from cycloSaligenyl-3'-azido-3'-deoxythymidine Monophosphates (cycloSal-AZTM)" *Eur. J. Org. Chem.*, 837-846 (1998).
- 49. Meier, C, Knispel, T., De Clerq, E., Balzarini, J.** "ADA-Bypass by Lipophilic CycloSal-ddAMP Pro-nucleotides a Second Example of the Efficiency of the CycloSal-concept" *Bioorg. Med. Chem. Lett.*, 7, 1577-1582 (1997).
- 50.Meier, C, Knispel, T., De Clerq, E., Balzarini, J.** "CycloSal-pronucleotides of 2',3'-Dideoxyadenosine and 2', 3'-Dideoxy-2',3'-dideoxyadenosine: Synthesis and Antiviral Evaluation of a Highly Efficient Nucleotide Delivery System" *J. Med. Chem.*, 42, 1604-1614(1999).
- 51.Meier, C, Knispel, T., Marquez, V.E., Siddiqui, M.A., De Clerq, E., Balzarini, J.** "CycloSal-Pronucleotides of 2'-Fluoro-ara- and 2'-Fluoro-ribo-2',3'-dideoxyadenosine as a Strategy to Bypass a Metabolic Blockade" *J. Med. Chem.*, 42,1615-1624 (1999).
- 52.Bloch, A., Robins, M J., McCarthy, J.R., Jr.** "The role of the 5'-Hydroxyl Group of Adenosine in Determining Substrate Specificity for Adenosine Deaminase" *J. Med. Chem.*, 10,908-912(1967).
- 53.McGuigan, C, Camarasa, M.-J., Egberink, H., Hartmann, K., Karlsson, A., Perno, C.F., Balzarini, J.** "Design, synthesis and biological evaluation of novel nucleotide prodrugs as inhibitors of HIV replication" *Int. Antiviral News*, 5, 19-21 (1997).
- 54. Siddiqui, A.Q., Ballatore, C, McGuigan, C, De Clerq, E., Balzarini, J.** "The Presence of Substituents on the Aryl Moiety of the Aryl Phosphoramidate Derivative of d4T Enhances Anti-HIV Efficacy in Cell Culture: A Structure-Activity Relationship" *J. Med. Chem.*, 42, 393-399 (1999).
- 55.McGuigan, C, Cahard, D., Sheeka, H.M., De Clercq, E., Balzarini, J.** "Aryl Phosphoramidate Derivatives of d4T Have Improved Anti-HIV Efficacy in Tissue Culture and May Act by the Generation of a Novel Intracellular Metabolite" *J. Med. Chem.*, 39, 1748-1753 (1996).

- 56. Balzarini, J., Karlsson, A., Aquaro, S., Perno, C.-F., Cahard, D., Naesens, L., De Clercq, E., McGuigan, C.** "Mechanism of anti-HIV action of masked alaninyl d4T-MP derivatives" *Proc. Natl. Acad. Sci. USA*, *93*,7295-7299 (1996).
- 57. Balzarini, J., Egberink, H., Hartmann, K., Cahard, D., Vahlenkamp, T., Thormar, H., De Clercq, E., McGuigan, C.** "Antiretrovirus Specificity and Intracellular Metabolism of 2',3'-Didehydro-2',3'-dideoxythymidine (Stavudine) and Its 5'-Monophosphate Triester Prodrug So324" *Mol. Pharmacol.*, **50**, 1207-1213 (1996).
- 58. Balzarini, J., Wedgwood, O., Kruining, J., Pelemans, H., Heijntink, R., De Clercq, E., McGuigan, C.** "Anti-HIV and Anti-HBV Activity and Resistance Profile of 2', 3'-Dideoxy-3'-Thiacytidine (3TC) and Its Arylphosphoramidate Derivative CF 1109" *Biochem. Biophys. Res. Comm.*, **225**,363-369 (1996).
- 59. McGuigan, C, Pathirana, R.N., Balzarini, J., De Clercq, E.** "Intracellular Delivery of Bioactive AZT Nucleotides by Aryl Phosphate Derivatives of AZT" *J. Med. Chem.*, *36*, 1048-1052 (1993).
- 60. Balzarini, J., Kruining, J., Wedgwood, O., Pannecouque, C, Aquaro, S., Perno, C.-F., Naesens, L., Witvrouw, M., Heijntink, R., De Clercq, E., McGuigan, C.** "Conversion of 2', 3'-Dideoxyadenosine (ddA) and 2', 3'-Didehydro-2\ 3'-dideoxyadenosine (d4A) to Their Corresponding Aryloxyphosphoramidate Derivatives Markedly Potentiates Their Activity Against Human Immunodeficiency Virus and Hepatitis B Virus" *FEBS Letters*, **410**,324-328 (1997).
- 61. McGuigan, C, Wedgwood, O. M., De Clercq, E., Balzarini, J.** *Bioorg. Med. Chem. Lett.*, *6*,2359-2362 (1996).
- 62. Meyers, C.L.F., Borch, R.F.** "Activation Mechanism of Phosphoramidate Prodrugs" *J. Med. Chem.*, *43*,4319-4327 (2000).
- 63. Balzarini, J., Egberink, H. Hartmann, K., Karlsson, A., Perno, C.-F., Cahard, D., Naesens, L., Thormar, E., De Clercq, E., McGuigan, C.** "Mechanism of Anti-HIV Action of Masked Alaninyl 2',3'-Dideoxy-2',3'-Didehydrothymidine 5'-Monophosphate Derivatives" *Antiviral Res.*, *30*, A18 (1996).



- 64. Kumar, A., Coe, P.L., Jones, A.S., Walker, R.T., Balzarini, J., De Clerq, E.** "Synthesis and Biological Evaluation of Some Cyclic Phosphoramidate Nucleoside Derivatives" *J. Med. Chem.*, 33,2368-2375 (1990).
- 65. McGuigan, C, Tsang, H.-W., Cahard, D., Turner, K., Velazquez, S., Salgado, A., Bidois, L., Naesens, L., De Clercq, E., Balzarini, J.** "Phosphoramidates Derivatives of d4T as Inhibitors of HIV: The Effect of Amino Acid Variation" *Antiviral Res.*, 35, 195-204 (1997).
- 66. Meyers, C.L.F., Hong, L., Joswig, C, Borch, R.F.** "Synthesis and Biological Activity of Novel 5-Fluoro-2'-deoxyuridine Phosphoramidate Prodrugs" *J. Med. Chem.*, 43, 4313-4318 (2000).
- 67. Farquhar, D., Kuttesch, N J., Wilkerson, M.G., Winkler, T.** "Synthesis and Biological Evaluation of Neutral Derivatives of 5'-Fluoro-2'-Deoxyuridine 5'-Phosphate" *J. Med. Chem.*, 26,1153-1158(1983).

**Başyuru Tarihi: 01.06.2001**

**Kabul Tarihi: 29.06.2001**