



## Examination of the Performance of Spoon-Type Planting Machine in Kastamonu Taşköprü Garlic Planting

Atilla Verep<sup>a</sup>, Hüseyin Güran Ünal<sup>b,\*</sup>

<sup>a</sup>Institute of Science Kastamonu University, Kastamonu, Türkiye

<sup>b</sup>Department of Mechanical Engineering, Faculty of Engineering, Kastamonu University, Kastamonu, Türkiye

\*Corresponding author: gunal@kastamonu.edu.tr

Received: September 30, 2024 ◆ Accepted: December 12, 2024 ◆ Published Online: December 25, 2024

**Abstract:** Garlic production and consumption are increasing worldwide, including in Turkey. It has a wide place on tables due to its taste and health benefits. Kastamonu Taşköprü garlic is also a geographically indicated variety known and sought after worldwide due to its sharp aroma. Approximately 20% of garlic in Türkiye is produced in Kastamonu. Garlic is the most important agricultural product in the Kastamonu economy. Thousands of tons of garlic reach consumers unprocessed, in the form of hand-tied garlic, and are placed on tables. Apart from this, netted garlic in markets, peeled garlic, puree, and black garlic, used primarily in sausage-pastırma-pickle-food sectors, are also processed in facilities in Kastamonu and marketed nationwide. Due to the intensive labor requirement in production, production costs and the supply of labor requirements limit garlic production amounts in the region. In recent years, the use of machinery in planting has become widespread. The spoon-type planting machines are used to plant in rows and then facilitate operations such as weeding and uprooting. This study investigated the success of the spoon-type garlic planting machines used in the region with Kastamonu garlic. The field trials revealed planting performance with the sprout spacing measurement and camera image analysis with different speeds, tooth sizes, and field slope variables. As a result of the results obtained, it was seen that the spoon-type machine was far from making precise planting. When plant distribution was evaluated according to the row spacing in all variables, it was determined that the acceptable row spacing rate was insufficient (11.7-79.5%). It is possible to say that it scatters garlic randomly on the row. These machines need to be developed, and losses in garlic planting should be reduced.

**Keywords:** Garlic, Kastamonu, planting mechanization, resource efficiency, sustainable agriculture

**Öz:** Sarımsak üretimi ve tüketimi tüm Dünya’da ve Türkiye’de artmaktadır. Gerek lezzeti gerekse sağlık yönünden faydaları sebebiyle sofralarda geniş yer bulmaktadır. Kastamonu Taşköprü sarımsağı da coğrafi işaret sahibi, keskin aroması sebebiyle tüm dünyada tanınan ve aranan bir çeşittir. Türkiye’deki sarımsağın yaklaşık %20 si Kastamonu’da üretilmektedir. Sarımsak, Kastamonu ekonomisinde en önemli tarımsal üründür. Binlerce ton sarımsak işlenmeden, el bağı şeklinde tüketicilere ulaşmakta ve sofralarda yer almaktadır. Bunun dışında marketlerde yer alan filelenmiş sarımsak, başta sucuk-pastırma-turşu-gıda sektörlerinde kullanıma sunulan soyulmuş sarımsak, püre, siyah sarımsak gibi katma değeri yüksek ürünler de Kastamonu’daki tesislerde işlenip yurt geneline pazarlanmaktadır. Üretiminde yoğun işgücü gereksinimi sebebiyle üretim maliyeti ve işgücü ihtiyacının temini yörede sarımsak üretim miktarlarını kısıtlamaktadır. Son yıllarda ekim işlerinde makine kullanımı yaygınlaşmaya başlamıştır. Kullanılan kaşıkçıklı tip ekim makineleri sıraya ekim yapmakta, sonrasında ot alma, söküm gibi işlemlerin yapılmasını da kolaylaştırmaktadır. Bu çalışmada bölgede kullanılan kaşıkçıklı tip sarımsak ekim makinelerinin Kastamonu sarımsağı ile kullanıldığındaki ekim başarısı araştırılmıştır. Yapılan tarla denemelerinde farklı hız, diş büyüklüğü, tarla eğimi gibi değişkenlerle filiz aralık ölçümü ve kamera görüntüsü analizi ile ekim performansı ortaya konmuştur. Elde edilen sonuçlar neticesinde kaşıkçıklı tip makinanın hassas ekim yapmaktan oldukça uzak olduğu görülmüştür. Tüm değişkenlerde sıra üzeri mesafeye göre bitki dağılımı değerlendirildiğinde, kabul edilebilir sıra üzeri aralık oranının yetersiz olduğu saptanmıştır (%11.7-79.5). Sıra üzerine gelişi güzel sarımsak döktüğünü söylemek mümkündür. Bu makinelerin geliştirilerek sarımsak ekimindeki kayıpların azaltılması gerekmektedir.

**Anahtar Kelimeler:** Sarımsak, Kastamonu, ekim mekanizasyonu, kaynak verimliliği, sürdürülebilir tarım

### 1. Introduction

The scientific name for garlic in Latin is *Allium sativum*, which means “a burning plant”. Its thin green leaves, white roots, and pungent odor indicate that garlic is a member of the Allium genus, like onions and leeks. Garlic, used as a vegetable, is a plant that has been used in all cultures since ancient times as a condiment and as a medicine [1]. Garlic has gone far beyond being a plant that is only used dried or fresh due to its unique qualities. Garlic products available on the market are generally in the form of garlic tablets, garlic vinegar, garlic yogurt, garlic olives, garlic puree, garlic capsules, garlic mustard, (a wide variety) garlic sauces, garlic powder, garlic essential oil, garlic juice (extract), dried garlic, and garlic pickles [2], Kızılaslan and Tokatlı [3], in their study investigating the effects of garlic on human health, stated that

it has anti-inflammatory, antidiabetic, antioncogenic, antimicrobial, antioxidant, cardioprotective, immunomodulatory and hepatoprotective effects and recommended including garlic in daily nutrition. While 28,204,854 tons of garlic were produced in the world in 2021 [4], 0.4% of it was produced in Turkey with 132,617 tons [5]. Approximately 25% of Türkiye's production was produced in Kastamonu, which produced 33,122 tons. Taşköprü garlic, which is the most widely grown garlic variety in Turkey due to its sharp aroma and long-term preservation, is also known as white gold [6]. Garlic is the agricultural product that provides the most employment for Kastamonu Taşköprü District. Approximately 4000 families in Taşköprü sustain their lives with garlic production. This means 75% of the population sustains their lives with garlic income. Since garlic farming requires much labor, it plays an important role in the employment of the population in the Kastamonu-Taşköprü region. For this reason, in Kastamonu, where people emigrate due to limited sources of income, garlic farming has become an important source of income by tying the population to the field [7].

In today's world, where labor supply difficulties and costs are rapidly increasing, agricultural mechanization needs to be increased. The most critical factor in providing equal living space for plants is the precise planting of seeds. Planting precisely with equal distances between rows and on the row also provides convenience in weed control, fertilization, and harvesting processes in the advanced stages of production. Garlic production in Kastamonu requires intensive labor for planting, weed hoeing, harvesting, grading, and cleaning. Planting by hand-sprinkling also makes removing weeds from the randomly scattered seeds difficult. In order to provide equal living space for plants, precision planting machines that control the distances between rows and on the rows are essential. Due to its large and irregular structure, planting garlic cloves with a machine is more complex than other seeds. In recent years, the number of spoon-type garlic planting machines has increased with the search for mechanization in production. In a study conducted in 2008, when producers were asked about their most significant need for mechanization, 61.61% responded that planting and 16.67% responded that seed nipping was the most common [8]. In a study conducted in 2023, 27.8% of producers planted with machines, while 90.9% removed with machines [9]. Although producers have a high need for mechanization, their use of machines remains limited. This is because the planting machines used in the region did not show the expected performance and did not satisfy the users, and the teeth were not placed vertically in the soil as they were planted by hand. Tüfekçi et al. [10] tested the performance of the spoon-type planting machine in a laboratory environment during planting with Kahramanmaraş garlic. Ünal and Keskin [11] made the pneumatic planting machine suitable for garlic planting by changing the planting unit in their study on Taşköprü garlic and conducting a field trial. With this machine whose planting unit was changed, the empty crossing rate was 12.4%, the twinning rate was 6.2%, and the acceptability rate was 81.4%. Feng et al. [12] designed a pneumatic garlic planting machine, and in the trial, they conducted with this machine, they achieved 3.31% twinning, 8.65% empty crossing, and 88.04% acceptability. There is no study on the field performance of spoon-type planting machines, the only machines used in garlic planting in Kastamonu. Kastamonu garlic is used without examining its suitability for these machines. In this study, the spoon-type garlic planting machine used in garlic planting in Kastamonu was tested, and planting performance was examined using sprout spacing measurement and a camera image. Low planting performance leads to major losses due to failure to provide ideal equal living space for plants. The increase in twinning rate causes the cloves falling close to each other not to develop sufficiently and the garlic heads to remain small. The increase in empty crossing causes the field to be filled insufficiently by falling below the ideal number of plants per unit area. For example, a 10% loss leads to approximately 300,000,000 TL in Kastamonu, where 33000 tons of garlic are produced annually. For this reason, it is imperative to analyze the performance of the machines to be used and to improve their success.

**2. Material and Method**

**Biological material used in the experiments**

Taşköprü garlic grown in 2023 in the Kastamonu region was used in the study. After the garlic were in a cool warehouse away from sunlight until the planting season, they were separated into cloves in a clove-cutting machine 1 day before planting and divided into 3 classes as large, medium and fine types with the help of a round-hole rotary drum sieve. With the help of the drum sieve, 3 batches of 20 garlic cloves were taken to represent each class according to their sizes and the dimensions of these garlic cloves were measured with a precision of 0.1 mm with the help of a caliper and the averages and standard deviations of their basic dimensions (L: length, W: width, T: thickness) were calculated. In addition, the shape features found with the help of the following relations were also calculated. 20 garlic cloves were taken randomly from the garlic cloves in 3 batches representing each size and weighed on a precision scale. The samples were found to weigh 1000 grains. In addition, in order to calculate the dry matter weights of the same samples, they were separated into sizes and heated in an oven set at 105 degrees for 24 hours [13] and the weights were weighed on a precision scale. All these properties of the seeds used are given in Table 1.

$$\text{Grain volume (V) ) } \quad B=\sqrt{WT} \quad V=\frac{\pi B^2 L^2}{6(2L-B)} \quad \dots\dots \quad (1) [14]$$

$$\text{Sphericity (Ø) } \quad \text{Ø}=\frac{(LWT)^{1/3}}{L} \quad \dots\dots \quad (2) [15]$$

Shape ratio (Ra)  $Ra = \frac{W}{L}$  ..... (3) [14]

**Table 1.** Characteristics of the seed garlic cloves used

Small clove		Medium clove		Large clove		Mix clove	
Dimensions (mm)							
W	L	T	W	L	T	W	L
8.9±2	27.2±4	6.9±2	12.6±2	29.1±4	8.8±1	17.0±3	31.2±4
Shape features							
V(mm <sup>3</sup> )	Ø	Ra	V(mm <sup>3</sup> )	Ø	Ra	V(mm <sup>3</sup> )	Ø
505.4	0.4	0.3	1023.8	0.5	0.4	1803.6	0.5
Thousand-grain weight (gr)							
1055±55	1965±280	3050±115	2005±150	1055±55	1965±280	3050±115	2005±150
Dry matter ratio (%)							
43.6	41.22	41.15	41.65	43.6	41.22	41.15	41.65

**Garlic planter**

A Massey Ferguson 2635 tractor was used as a power source to pull the Çalışkan brand spoon planter used during the study. The planter operates at a fixed 16.5 cm row spacing and 6-8-10 cm row spacing that can be adjusted with the help of gears. The planter specifications are given in Table 2.

**Table 2.** Planter technical data

Brand	Çalışkan
Model	HC1-13
Row spacing (cm)	16.5
Number of planting units (pcs)	13
Planting width (cm)	248
Seed storage capacity (kg)	80
Tire size	165 x70 r13
Weight (kg)	800
Power requirement (hp)	70-80hp
Plantable area (m <sup>2</sup> /sa)	4500
Transport dimensions (cm)	160 x 276 x 145
above line spacing (cm)	6, 8, 10

**Garlic planter seed storage compartmentation**

Since the seed storage of the garlic planter we used has a single compartment and 13 rows, the seed storage compartment was divided into compartments with cardboard sheets to examine the planting performance of seeds of different sizes. The seed storage compartment was divided into four compartments with 3-3-3-4 spoon rows to accommodate fine, medium, large, and mixed seeds, respectively (Figure 1).



**Figure 1.** Seed chamber compartments

### Spoonlets

Detailed views of the spoonlets on the 13-row planting machine are given in Figure 2.

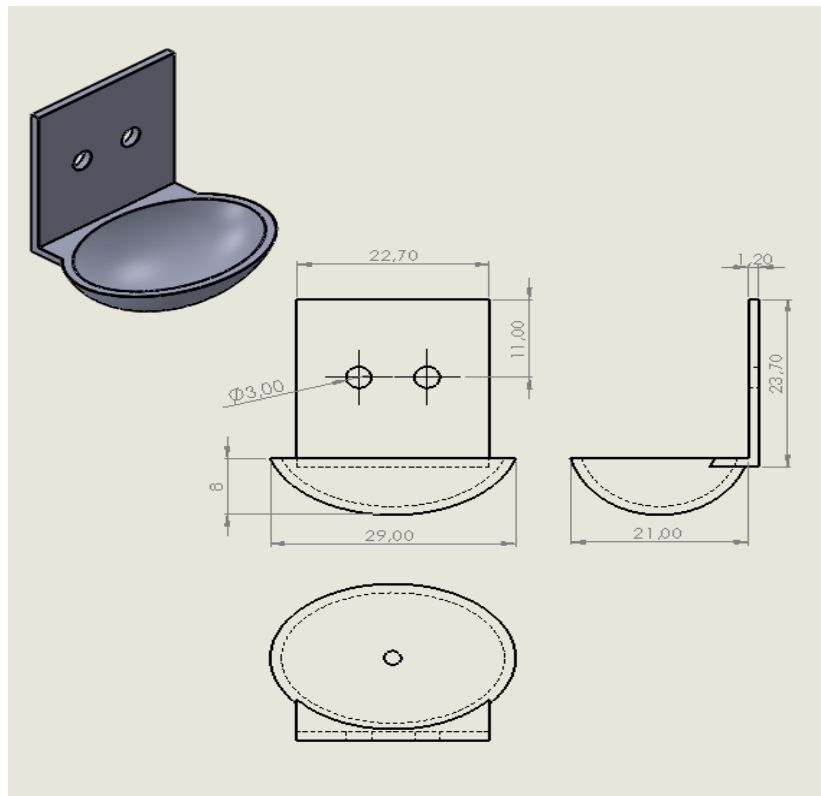

**Figure 2.** Technical drawings of the spoonlets used in the planting machine

### A field where the study was conducted

The study was conducted on February 20, 2024, in the field numbered 106 islands and 16 parcels in the Yukarı Dere location of the Karacaoğlu Neighborhood of Meşeli Village of Taşköprü district of Kastamonu Province. The field is approximately 700 m above sea level and has a slope of approximately 11%. Preparation studies were carried out in the field in the autumn season and before planting the year before planting. Two different slopes were used in this area: downward and upward.

8 cm was preferred as the distance between rows in all trials. Forward speed trials were conducted at three different gears, 1100 rpm engine speed, V1-1.32, V2-2.59, V3-3.62 km/h speeds.



**Figure 3.** The field where the experiment was conducted

**Determination of plant distribution uniformity on the row with sprout spacing measurement**

After the field trial conducted on 20.02.2024, the sprouts were expected to emerge completely, and the sprouts were measured on 23.04.2024. The distance on the row was theoretically set to 8 cm during the planting process. Since  $Z=8$  cm was taken, as a result of measuring the sprout spacing, intervals narrower than 4 cm were considered twinning, intervals larger than 12 cm were considered empty crossing, and measurements between 4-12 cm were considered acceptable intervals [16] (Table 3).

**Table 3.** Evaluation of plant distribution according to row spacing [16]

Definition	Plant spacing on row
Twinning	$< 0.5 Z$
Acceptable spacing	$\geq 0.5Z - \leq 1.5Z$
Spacing	$> 1.5 Z$

In order to determine the regularity of the sprouts emerging on the row, the distances between the thin, medium, large, and mixed-sized garlic sprouts planted on the 15 m tracks determined for each speed level were measured. In this process, which was carried out with five repetitions for each size of garlic sprouts on each track, the distances of the plants on the rows within 120 cm randomly selected were measured. The averages obtained were evaluated in Table 4.

**Table 4.** Evaluation of acceptable twinning and void ratios [16]

Acceptable	Twinning rate	Spacing rate	Evaluation
Plant spacing rate (%)	(%)	(%)	
>99	<0.5	<0.5	very good
>95-99	<0.5-2.5	<0.5-2.5	good
>90-95	<2.5-5.0	<2.5-5.0	average
>80-90	<5.0-10.0	<5.0-10.0	sufficent
<80	>10.0	>10.0	Inadequate



**Evaluation with the camera image**

A total of 13 spoon bands of the precision planting machine, divided into four different chambers during planting, were recorded with a camera. Camera recordings were made with two mobile phones carried by two people. The recording with one camera is listed on half of the machine's spoons. The camera records were then examined slowly, and the garlic cloves taken with each spoon were counted. While counting the camera images, images of 10 spoons with five replications at different times for each variable were examined. Spoons with more than one tooth were calculated as twinning, spoons with one tooth were calculated as standard, and spoons with no teeth were calculated as empty crossing.



**Figure 4.** Taking images with a camera during planting

**3. Result and Discussion**

**Twinning rate**

The upslope and downslope twinning rates obtained by the measurement of shoot spacing and camera image analysis during the field trial are given in Table 5, respectively.

**Table 5.** Twinning rates

	According to sprout range measurement twinning rate on upslope (%)				According to the camera image twinning rate on upslope (%)			
	Small	Medium	Large	Mix	Small	Medium	Large	Mix
V 1	15.7±15.5	10.2±4.6	8.3±13.1	17.4±13.1	67.1±34.0	8.3±5.0	13.3±10.3	27.3±12.8
V 2	29.7±10	11.4±9.3	14.7±20.9	10.6±8.0	52.9±35.4	15.0±10.0	17.1±13.8	11.8±9.9
V 3	30.5±13.6	6.3±10.3	6.4±3.9	4.2±7.6	31.4±32.8	8.8±9.8	5.7±7.9	11.6±10.7
	Twinning rate on down slope (%)				Twinning rate on down slope (%)			
V 1	33.0±12.0	10.8±14.4	16.3±12.1	8.9±9.9	70.0±34.2	33.8±33.8	40.0±26.1	37.0±24.9
V 2	25.5±7.7	17.5±15.3	3.6±7.9	10.1-12.2	88.3±34.1	24.4±24.0	83.3±23.6	20.0±28.3
V 3	9.5±7.2	28.4±13.7	4±8.9	8.0±11.0	78.3±30.4	8.9±9.3	21.1±10.5	15.0±4.8

**Vacancy rate**

The upslope and downslope vacancy rates obtained by measuring shoot spacing and camera image analysis during the field trial are given in Table 6.

**Table 6.** Vacancy rates

	According to sprout range measurement vacancy rate on upslope (%)				According to the camera image vacancy rate on up slope (%)			
	Small	Medium	Large	Mix	Small	Medium	Large	Mix
V 1	42.6±24.6	50.4±17.9	79.8±15.4	58.0±17.6	7.9±10.3	26.7±12.9	21.7±34.3	2.5±4.6
V 2	33.0±11.3	65.1±26.7	67.3±29.4	64.6±15.7	10.0±14.6	10.0±15.3	9.2±9.3	13.6±10.3
V 3	27.8±11.5	75.2±18.0	70.5±18.8	78.5±20.7	12.9±14.6	20.0±8.9	14.8±10.7	11.4±13.5
	Vacancy rate on down slope (%)				Vacancy rate on down slope (%)			
V 1	24.2±7.4	69.5±17.3	60.3±13.5	60.8±20.2	5.0±7.9	14.2±13.7	1.7±4.1	8.1±10.7
V 2	33.2±9.9	45.1±11.2	81.4±24.9	57.1±21.3	0.0±0.0	13.3±18.0	0.0±0.0	10.0±14.1
V 3	62.5±20.4	27.3±13.7	71.3±24.1	70.9±17.1	3.3±4.9	36.7±30.4	8.3±7.5	17.5±9.2

**Acceptable rates**

The acceptable rates of upslope and downslope obtained by the measurement of shoot spacing and camera image analysis during the field trial are given in Table 7, respectively.

**Table 7.** Acceptable rates

	According to sprout range measurement acceptable rate on upslope (%)				According to the camera image acceptable rate on upslope (%)			
	Small	Medium	Large	Mix	Small	Medium	Large	Mix
V 1	41.6±18.6	39.3±15.2	11.9±6.0	24.6±19.1	27.1±23.3	65.0±9.6	65.0±27.4	70.2±13.1
V 2	37.3±14.8	23.5±22.0	18.0±14.3	24.9±12.5	34.3±23.9	75.0±12.9	73.7±11.9	74.6±9.9
V 3	41.6±18.3	18.4±12.5	23.2±17.3	17.3±17.0	55.7±29.5	71.3±14.7	79.5±13.4	77±12.4
	Acceptable rate (%) on down slope				Acceptable rate (%) on down slope			
V 1	42.8±13.2	19.6±16	23.4±12.3	30.3±18.6	25.0±21.2	52.1±23.4	58.3±26.4	54.8±23.6
V 2	41.3±12.9	37.4±18.2	15±20.9	32.8±16.6	11.7±8.2	62.2±23.3	16.7±23.6	70.0±42.4
V 3	28±22	44.3±8.9	20.6±23.1	21±18.9	18.3±9.8	53.3±27.8	63.9±18.8	67.5±12.2

In all variables, twinning was determined as 4.0-33.0% according to the measurement between the sprouts, and 5.7-88.3% according to the image analysis. Vacancy was determined as 24.2-81.4% according to the measurement between the sprouts, and 0.0-36.7% according to the image analysis. According to the measurement between the sprouts, the acceptable was determined as 11.9-44.3%, and 11.7-79.5% according to the image analysis.

When the effect of tractor forward speed is evaluated, in the average of all variables, the acceptable rate is determined as 29.2, 28.8, 26.8% in V1, V2, V3 speeds according to the tiller measurement, and 52.2, 52.3, 60.8% according to the camera image. It is seen that the acceptable rate decreases as the speed increases according to the tiller measurement, and the acceptable rate increases according to the camera image. The results obtained with the tiller spacing measurement values are also consistent with the results of other researchers [17-19]. When the effect of the terrain slope is evaluated, in the average of all variables, the acceptable rate is determined as 26.8% and 30.1% in the up and down slopes according to the tiller measurement, and 64.0% and 45.5% in the up and down slopes according to the camera image, respectively. According to the measurement between the sprouts, the acceptable rate is lower on the upward slope. In contrast, according to the camera image, the acceptable rate is higher on the upward slope. Ünal [20] reported in his study that the seed tube's angle, height, and material are effective in garlic cloves' falling times.

When the effect of garlic clove sizes is examined, in the average of all variables, the acceptable rate was determined as 38.8, 30.4, 18.7, and 25.2% for small, medium, large, and mixed garlic clove sizes according to the measurement between the sprouts, and 28.7, 63.2, 59.5, 69.0% according to the camera image, respectively. It is seen that the acceptable rate decreases as the garlic clove sizes increase according to the measurement between the sprouts, while the acceptable rate increases as the garlic clove sizes increase according to the camera image.

In the average of all variables, the acceptable rate was 28.4% according to the measurement between the sprouts and 54.7% according to the camera image. In general, the acceptable rates obtained with the camera image are higher. These values show the actual filling amount of the spoons. The number of sprout intervals is misleading in showing the spoons' filling performance. It varies depending on falling height, seed tube slope, seed tube material, the possibility of rebound and drifting after falling, and the sprout's emergence direction.

**Evaluation of the planter success**

According to the sprout spacing measurement and camera image analysis of the planter used in the study, the sufficiency status of garlic seeds in two different slopes, three different progress speeds, and four different sizes is shown in Table 8.

**Table 8.** Qualification status of the planter

Qualification status according to sprout range measurement																							
Small						Medium						Large						Mix					
ye			ae			ye			ae			ye			ae			ye			ae		
ie	bs	kl	ie	bs	kl	ie	bs	kl	ie	bs	kl	ie	bs	kl	ie	bs	kl	ie	bs	kl	ie	bs	kl
V 1	x	x	x	x	x	x	x	x	x	x	x	x	x	x	x	x	x	x	x	x	x	x	x
V 2	x	x	x	x	x	x	x	x	x	x	x	x	x	x	o	x	x	x	x	x	x	x	x
V 3	x	x	x	z	x	x	z	x	x	x	x	x	z	x	x	o	x	x	o	x	x	z	x

Qualification status according to camera image																							
Small						Medium						Large						Mix					
ye			ae			ye			ae			ye			ae			ye			ae		
ie	bs	kl	ie	bs	kl	ie	bs	kl	ie	bs	kl	ie	bs	kl	ie	bs	kl	ie	bs	kl	ie	bs	kl
V 1	x	z	x	x	z	x	z	x	x	x	x	x	x	x	x	i	x	x	i	x	x	z	x
V 2	x	z	x	x	c	x	x	z	x	x	x	x	z	x	x	c	x	x	x	x	x	z	x
V 3	x	x	x	x	o	x	z	x	x	z	x	x	z	x	x	z	x	x	x	x	x	x	x

ae: downward slope, ye: upward slope, x: insufficient, z: sufficient, o: average, i: good, c: very good, ie: twinning, bs: blank pass, kl: acceptable

When the obtained results regarding twinning, empty crossing, acceptable rates, and precision planting machine trial criteria are examined, it is possible to say that the machine is inadequate in all variables, and the seeds are left randomly on the row rather than precision planting. [10] Tüfekçi et al. determined the acceptable row spacings as 36-47-35%, respectively, with a forward speed of 0.25-0.5-1.0 km/h in laboratory experiments with a spoon-type garlic planter. In this study, in the experiments conducted with Maraş garlic, the row planting performance was found to be insufficient.

The reasons for the negativities can be listed as the inappropriateness of the spoon size and shape to the Kastamonu garlic clove size and shape, the absence of a mixer or a guide towards the spoons in the seed chamber, and the seed tubes being too high and curved. As a result of the producers not liking the performance of the spoon planting machines used in the region, their use remains low at 27.8%. The necessity of 79.6% of garlic cultivation with external labor supply causes farmers to produce in small plots that they can handle with their own families and not to be able to increase their planting areas [9].

In the field trial conducted by Ünal and Keskin [11] with the pneumatic garlic planter they developed, the best results were obtained with 12.4% space ratio, 6.2% twinning ratio, 81.4% normal planting ratio, 94.57% sprouting ratio and 42.79% coefficient of variation at 11.6 cm row spacing and 2.6 km/h machine forward speed.

It was seen in the study that it is not appropriate to determine the suitability of garlic planting machines to the trial criteria by measuring the sprout spacing. Considering the density of the row spacing (8 cm) and the size of the teeth (approximately 3 cm), measurements made according to the position of the sprout tips can be inaccurate, as seen in Figure 3. Even if the centers of the teeth are ideally 8 cm, the spacing of the sprouts on the soil can be closer than 4 cm and be perceived as twinning, or larger than 12 cm and be perceived as empty spacing. The significant difference between the results obtained with camera images and sprout spacing measurements proves this. Ünal and Keskin [11] reported that the method used to evaluate the test results is suitable for demonstrating the performance of existing precision planting machines but that this evaluation is not reliable for plants such as garlic and shallots, which are large, heavy, irregularly shaped, and have differences in the point at which the sprout emerges from the surface, rather than for small and more regular-shaped plant seeds such as sugar beet and corn.





**Figure 5.** Measurement errors of sprout spacing

Our study was also the first to determine planting performance with camera images during field trials. Although there are studies conducted with camera images and image processing techniques in laboratory environments in existing studies, image analysis was not encountered in field trials.

#### **4. Conclusion and Suggestions**

This research has shown that spoon machines used in garlic planting must be developed. With its current structure, it is impossible to say that it leaves seeds at equal intervals on the row; it is more appropriate to say that it pours them randomly on the row. It is necessary to approach the distances on the row to the ideal size, reduce twinning and empty crossing rates, and increase acceptable rates.

For this purpose, technical arrangements that can be made can be listed as follows:

- i) Spoonlet shape and dimensions should be revised for Kastamonu garlic.
- ii) Modifications should be made in the warehouse, such as adding a mixer or a vibration provider to ensure that the cloves are directed to the spoons.
- iii) A mechanism should be worked on to ensure that the excess seeds in spoons that hold more than one garlic clove are dropped and singulated.
- iv) The point where the garlic falls from the spoonlets should be brought as close to the soil as possible, the drop pipe used in between should be shortened, and it should be ensured to be straight and vertical. Studies have shown that pneumatic machines used in garlic planting give better results. Such machines' development and widespread use will also contribute to a more uniform planting.

This research also showed that determining planting performance according to sprout spacing in garlic is misleading. Camera image examination provides more realistic results. Work on production mechanization, especially planting Taşkoprü garlic, the largest agricultural production in Kastamonu province, and providing a living for hundreds of families, should be encouraged and increased.

#### **Conflict of Interest**

The authors declare that they have no competing interests.

#### **Ethics Committee Approval**

Ethics committee approval is not required.

#### **Author Contribution**

Conceptization: AV, HGÜ; methodology and laboratory analyzes: AV, HGÜ; writing draft: AV, HGÜ; supervision: HGÜ, proof reading and editing: All authors have read and agreed to the published version of manuscript.

## Acknowledgements

This publication was prepared by using a part of the master's thesis study of Atilla Verep, Kastamonu University, Institute of Science, Department of Mechanical Engineering.

## 5. References

- [1] Rebecca L. J. & Stewen F. (2016) National Geographic Encyclopedia of Medicinal Plants:152-157.
- [2] Koyuncu, M. (2012). Garlic and Taşköprü Garlic. Taşköprü Garlic Panel Proceedings, (pp:11-20), 6 February 2012. Kastamonu.
- [3] Kızılaslan, N. & Tokatlı, K. (2021). Effects of garlic on human health. TOGÜ Journal of Health Sciences, 1(2), 62-71.
- [4] FAO, (2024). Statistical data of FAO. Retrieved from: <http://faostat.fao.org/site/567/default.asp> (access date: May 8, 2024).
- [5] TÜİK, (2024). Production statistics, <https://biruni.tuik.gov.tr/medas/?kn=92&locale=tr> (access date: August 11, 2024).
- [6] Ipek M, Ipek A, Simon PW. 2008. Molecular characterization of Kastamonu garlic: An economically important garlic clone in Turkey. *Scientia Horticulturae*, 115(2), 203-208.
- [7] Çetin, T. & Karakuş, U. (2005). Population Movements in Taşköprü (Kastamonu) District Center. Istanbul University and Turkish Geographical Society National Geographical Congress, 29-30 September 2005, Proceedings Book p.523-532.
- [8] Ünal, H.G., Saçılık, K. & Yurtlu, Y.B. (2010). A study on the determination of agricultural practices and approaches in Taşköprü garlic, 26. National Congress of Agricultural Mechanization, (pp. 263-271), Hatay, Turkey, (October 2010)
- [9] Ünal, H.G. (2024). Production Habits and Problems in Taşköprü Garlic, *Turkish Journal of Agriculture - Food Science and Technology*, 12(7), 1156-1161.
- [10] Tüfekçi Y., Çakır B. & Akdemir B.(2018). Investigation of the Effect of Spoonlet Type on Planting Performance and the Suitable Spoonlet Type in Garlic Planters, *Journal of Agricultural Machinery Science*, 14(3), 179-187.
- [11] Ünal H.G. & Keskin R. (2005). Development of garlic planting machine prototype, *Journal of Agricultural Sciences* 11(3), 303-310.
- [12] Feng D., Li H., Qi X., Sun X, Wang J & Nyambura M.S. (2024). Design and laboratory experiments of a pneumatic disc-type garlic precision seed-metering device, *American Society of Agricultural and Biological Engineers*. 67(2), 451-460.
- [13] AOAC, (2000). Official Method of Analysis, Association of Official Analytical Chemists (No. 934.06), Washington, DC.
- [14] Al-Mahasneh, M. A. & Rababah, T. M. (2007). Effect of moisture content on some physical properties of green wheat. *Journal of food engineering*, 79(4), 1467-1473.
- [15] Dursun, E. & Dursun, I. (2005). Some physical properties of caper seeds. *Biosystems Engineering*, 92(2), 237-245.
- [16] Anonymous (1999). Agricultural mechanization tools testing principles and methods, Ministry of Agriculture and Rural Affairs p: 246, Ankara.
- [17] Karayel, D. & Özmerzi A. (2001). Effect of the distance and sowing speed in the row on the evenness of sowing in melon and cucumber planting with an air-suction single-grain planter system, *Journal of Akdeniz University Faculty of Agriculture*, 14(2), 63-67.
- [18] Ünal H.G. (2006). A study on the possibilities of planting shallots with a garlic planting machine prototype, *Journal of Agricultural Sciences*, 12(1), 37-43.
- [19] Karagülmez A., Konak M. & Özbek O. (2018). Effect of some operating parameters on the evenness of seed distribution in the row in a horizontal plate mechanical precision planter system, *Selçuk Journal of Agriculture and Food Sciences*, 32(3), 350-354.
- [20] Ünal H.G. (2003). Determination of the effect of seed tube material, falling angle and seed size on falling time in garlic, *Journal of Agricultural Sciences*, 10(3), 287-290.