

1-GUARDABLE SUBGRAPHS OF GRAPHS

NAZLİCAN ÇAKMAK AND EMRAH AKYAR

0009-0007-1289-926X and 0000-0003-3045-5092

ABSTRACT. Cops and Robbers game is played on a graph. There are two players in the game consisting of set of cops and only one robber. They play in respectively; on each player's turn, the player may either move to an adjacent vertex or stay in its vertex. If one of the cops comes into the vertex with the robber then the robber is captured. Therefore, game ends and cop wins the game. In this study, 1-guardable subgraphs of graphs in the game of Cops and Robbers is considered. It is mentioned about some special subgraphs and their relations. It is known that if the subgraph is 1-guardable then it must be isometric but the converse of this argument may not be true. We show that for the inverse to be true, some conditions must be added.

1. INTRODUCTION

The game of Cops and Robbers on graphs is presented by Quilliot firstly and advanced by Nowakowski and Winkler [1]. The game is played with two players named cop and robber. Initially, each player chose a vertex respectively on a graph. Players move to adjacent vertices or can stay their location. After some finite moves, cop wins if he comes to the same vertex with the robber. The robber wins if he can avoid the cop forever. The minimum number of cops needed to catch the robber is called cop number and denoted by $c(G)$. If cop number is 1 then graph is called cop-win graph. A graph which is $c(G) > 1$ is sometimes called robber-win. Introductory work about the cop number came in 1984 with Aigner and Fromme [2, 3]. Bonato and Nowakowski have written the book that gives the most detailed information [4].

To determine the cop number is a hard problem on the game of Cops and Robbers. If G is a graph of order n , then $c(G) = O(\sqrt{n})$ is known as Meyniel's conjecture [5]. This bound has been tried to improve and Frank showed that

$$c(n) \leq (1 + o(1))n \frac{\log \log(n)}{\log(n)}$$

Date: **Received:** 2024-10-10; **Accepted:** 2024-12-04.

2000 Mathematics Subject Classification. 05C57, 90D43.

Key words and phrases. Graphs, Cops and Robber, 1-Guardable.

for the cop number [5]. Chinifooroshan proved that

$$c(n) = O\left(\frac{n}{\log(n)}\right)$$

for the cop number of any graph G [6]. The best known upper bound for the cop number is given by Lu and Peg

$$c(n) = O\left(\frac{n}{2^{(1-o(1))\sqrt{\log_2 n}}}\right)$$

by using the probabilistic method [7].

An induced subgraph H of G is said to be k -guardable if, after finitely many moves, k cops can move only in the vertices of H in such a way that if the robber moves into H at round t , then he will be captured at round $t + 1$ for a constant integer $k \geq 1$. It was proved that the isometric path is 1-guardable [2].

In [8], it is shown that the cop number of generalized Petersen graph is at most 4 and also proved that finite isometric subtree of a graph is 1-guardable.

Quilliot was studied on retractions on graphs and he proved several theorems in [9] before the game is introduced. Retracts have an important role in the game. Let H be an induced subgraph of G . If there is a homomorphism f from G onto H that is identity on H which means $f(x) = x$ for every vertex $x \in H$. Then this map is said to be retraction and H is called retract of G . In [3], it was shown that retract of cop-win graph is also cop-win.

The number of moves is considered on cop-win graphs and it is called capture time. For a given graph with n vertices the capture time is bounded by $(n - 3)$ [10]. In another paper, this bound is improved and presented new upper bound as $(n - 4)$ for $n \geq 7$ and $\lfloor \frac{n}{2} \rfloor$ for $n \leq 7$ [11].

In this paper, we try to determine under what conditions the subgraph of a graph can be 1-guardable.

2. SOME SPECIAL SUBGRAPHS OF GRAPH

For the given graph $G = (V, E)$ and $H = (W, F)$, H is said to be *subgraph* of G if $W \subset V$ and $F \subset E$. Let $G = (V, E)$ be the any graph and $S \subset V$ be any subset of vertices of G . Then the *induced subgraph* $G[S]$ is the graph whose vertex set is S and whose edge set consists of all of the edges in E that have both endpoints in S . That is, for any two vertices $u, v \in S$, u and v are adjacent in $G[S]$ if and only if they are adjacent in G .

H is an *isometric subgraph* of G if $d_G(u, v) = d_H(u, v)$ for every vertices u, v in H . A *convex subgraph* H of an undirected graph G is a subgraph that includes every shortest path in G between its two vertices.

Proposition 1. The convex subgraph of a graph is an isometric subgraph.

Proof. Let G be any graph and H be a convex subgraph of G . Then H includes every shortest path in G between its two vertices. Hence, $d_G(u, v) = d_H(u, v)$ for $u, v \in G$. \square

Note that the converse of Proposition 1 may not be true. Although C_5 is isometric subgraph of W_6 but it is not convex subgraph (see Figure 1).

Proposition 2. The isometric subgraph of a graph is an induced subgraph.

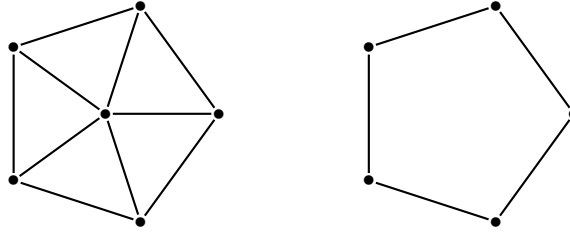
FIGURE 1. C_5 is an isometric subgraph of W_6 but not convex.

Proof. Let G be a graph and H be an isometric subgraph of G . Then assume that H is not induced subgraph of G . Then there exist $x, y \in V(H)$ such that the edge $xy \notin E(H)$. In this case, $d_G(x, y) = 1$ but $d_H(x, y) \neq 1$. This contradicts with H is isometric. If H is isometric subgraph of G then H must be induced subgraph of G . \square

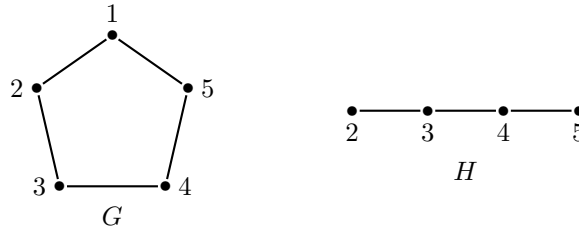
FIGURE 2. H is induced subgraph of G but not isometric.

If H is an induced subgraph of G then H may not be an isometric subgraph of G . It is seen easily in Figure 2. While $d_H(2, 5) = 3$, $d_G(2, 3) = 2$.

Corollary 2.1. *The convex subgraph of a graph is an induced subgraph.*

Proof. It is the conclusion of Proposition 1 and Proposition 2. \square

Proposition 3. *The convex subgraph of a graph is a retract.*

Proof. Let G be a graph and H be a convex subgraph of G . Thus, H is an induced subgraph of G . It can be defined f as a graph homomorphism such that

$$f : V(G) \rightarrow V(H), \quad f(v) = \begin{cases} \{u : d(u, v) = d(u, H)\} & , \text{ if } v \notin V(H) \\ v & , \text{ if } v \in V(H) \end{cases}$$

If the set $\{u : d(u, v) = d(u, H)\}$ has more than one element, only one element can be chosen from this set. \square

There is an example of homomorphism mentioned in the above proof in Figure 3. If homomorphism is defined as

$$f(v_1) = v_1, f(v_2) = v_2, f(v_3) = v_3, f(v_4) = v_4, f(v_5) = v_3, f(v_6) = v_2, f(v_7) = v_2$$

then f is a retraction from G onto H . It can be chosen $f(v_6) = v_3$ then there is a different retraction with the same graphs.

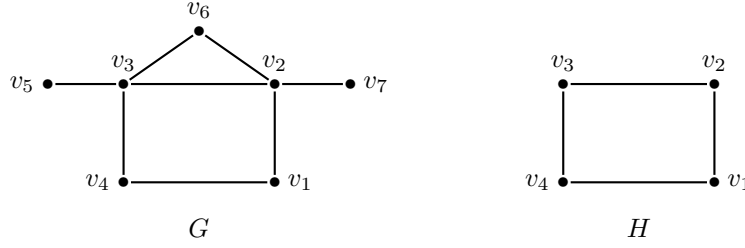

FIGURE 3. H is a convex subgraph which is a retract of G .

Corollary 2.2. *The convex subgraph of the cop-win graph is cop-win.*

Proof. Let G be a cop-win graph and H be a convex subgraph of G . Then, by Proposition 3 H is retract. It is known that if G is cop-win, then each retract of G is also cop-win. Hence convex subgraph of the cop-win graph is cop-win. \square

Proposition 4. The retract of a graph is an isometric subgraph.

Proof. Let G be a graph and H be retract of graph G so by definition, there exists a homomorphism $f : V(G) \rightarrow V(H)$ such that $f(x) = x$ for every $x \in V(H)$. In this case for any $x, y \in V(H)$, $f(x) = x$ and $f(y) = y$. Since f is the identity on $V(H)$ we get

$$d_H(f(x), f(y)) = d_H(x, y)$$

and by the definition of homomorphism

$$d_G(x, y) \geq d_H(f(x), f(y)) = d_H(x, y).$$

On the other hand, the shortest path between the vertices x and y can pass through the vertex u such that $u \in V(G) - V(H)$. So, this path does not stay entirely in H . Hence $d_G(x, y) \leq d_H(x, y)$ so equality $d_G(x, y) = d_H(x, y)$ is provided. Then, H is an isometric subgraph of G . \square

3. 1-GUARDABLE SUBGRAPHS OF GRAPH

Suppose that H is an induced subgraph of G and assume that k cops guard the subgraph H . Then after finitely many moves, for a fixed integer $k \geq 1$, H is said to be k -guardable if the robber moves into the subgraph H at round t then he is captured at round $t + 1$. Note that if one cop can guard a subgraph H in G , then H must be isometric in G . If it is not, then there are two vertices $u, v \in V(H)$ such that $d_H(u, v) > d_G(u, v)$. The robber can travel between u and v infinitely many times without being caught by the cop that guards H .

Note that there can also be subgraphs in G , not 1-guardable, although they are both isometric and cop-win (see Figure 4 and also see [12]).

Connected graph G is given and H is a subgraph of G . Let the set A be a set of access points to subgraph H and define as

$$A = \{v \in V(G) \setminus V(H) \mid N(v) \cap H \neq \emptyset\},$$

and for $v \in A$, define the set B_v such that

$$B_v = \{u \in V(H) \mid N_H(v) \subset N_H(u)\}$$

as the set of points in H that watch the points in set A . Let the set $B = \bigcup_{v \in A} B_v$ be (see Figure 5). Following conclusions can be given according to these notations.

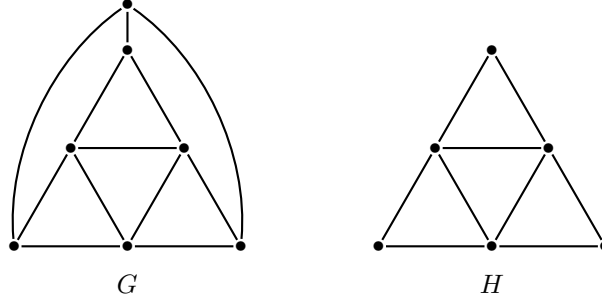

FIGURE 4. An isometric subgraph H of G is cop-win but H is not 1-guardable in G .

Lemma 3.1. *If $B_v \neq \emptyset$ for all $v \in A$ and*

$$d_G(v_1, v_2) \geq \max\{d_H(x, y) : x, y \in B\},$$

for every $v_1, v_2 \in A$ then H is an isometric subgraph of G .

Proof. Let x and y be any vertices of subgraph H . There are three cases:

- (1) Let $x, y \in B$. If x and y are adjacent or the same vertices, there is nothing to prove. If they are not adjacent, by the definition of sets A and B and assumption $d_H(x, y)$ can not be different from $d_G(x, y)$.
- (2) Let $x \in B$ and $y \notin B$. So the shortest path between x and y must be in H . Otherwise, let the path P be the shortest path between x and y but not in H so there exists a vertex $z \in A$ on the path P . Since $z \in A$ there is a vertex $z' \in B$ watching z . Hence there is another path for $u_1, u_2, \dots, u_k \in B$ and $w \in H$ such that

$$P' : y \rightarrow \dots \rightarrow z \rightarrow w \rightarrow z' \rightarrow u_1 \rightarrow u_2 \rightarrow \dots \rightarrow u_k \rightarrow x.$$

By the inequality given by assumption, the path P' is shorter than the path P . This contradicts with P being the shortest path. Hence shortest path P between x and y must be in H .

- (3) Let $x, y \notin B$. Proof is similar to the previous case. Thus H is an isometric subgraph. □

Lemma 3.2. *If $B_v \neq \emptyset$ for all $v \in A$ and induced subgraph $G[B]$ is a complete graph then H is 1-guardable.*

Proof. Let cop be positioned at one of the vertices of set B and let the robber be positioned at one of the vertices r_i which is seen in Figure 5. The cop is watching the robber at one of the vertices $u_i \in B$ and let the next move of robber go through one of the vertices v_i . When the robber moves over from vertices v_i to subgraph H , cop comes to one of the vertices $u_i \in B_{v_i}$ corresponding to vertex v_i . Since $G[B]$ is a complete graph then the robber is captured on the next move. Hence H is 1-guardable. □

If the set $G[B]$ is not complete then H may not be 1-guardable. Let's explain briefly: If B is not complete then cop can not be moved between vertices in B . So, the robber can not be captured when he comes into subgraph H .

It is a strict condition that the induced subgraph $G[B]$ is a complete graph. If the robber can enter the subgraph H from only one vertex, this condition can be loosened.

Theorem 3.3. *Let G be a graph, H is a subgraph of G . If there exists a vertex $x \in V(G) \setminus V(H)$ such that $|N_s(x) \cap A| > 1$ for $s > 0$ then let $k = \min\{s : |N_s(x) \cap A| > 1, x \in V(G) \setminus V(H)\}$, otherwise we set $k = d(R, A)$. If for all $v \in A$, $B_v \neq \emptyset$ and the inequalities*

$$\max\{d(x, y) : x, y \in B\} \leq k$$

and

$$\min\{d(v_1, v_2) : v_1, v_2 \in A\} \geq \max\{d(x, y) : x, y \in B\}$$

are valid then H is 1-guardable.

Proof. There are two cases:

- (1) Let w be a vertex satisfying $k = \min\{s : |N_s(x) \cap A| > 1, x \in V(G) \setminus V(H)\}$. When the robber comes to vertex w , then the cop moves towards to vertices that watch the adjacent vertices of the vertex w in the set A . Because of the inequality $\max\{d(x, y) : x, y \in B\} \leq k$ given with statement of theorem, cop can make these moves. Therefore, the cop waits the robber on one of the vertices $u_i \in B_{v_i}$. So the robber is captured in one move when he comes to subgraph H .
- (2) Suppose that there is no vertex w satisfying the conditions given in theorem. It can be mentioned about two cases:
 - (a) There are adjacent vertices in set A . In this case, because of the inequality $\min\{d(v_1, v_2) : v_1, v_2 \in A\} \geq \max\{d(x, y) : x, y \in B\}$, induced subgraph $G[B]$ must be complete graph. Then cop can move to any vertex in B that he wants. Therefore the robber is captured in one move when he comes to subgraph H .
 - (b) If there is no adjacent vertices in set A . Then there is a path between R and set A and the robber moves on this path. Because of the both inequalities given in theorem, the cop can comes to vertex $u_i \in B_{v_i}$. Thus the robber is captured in one move when he comes to subgraph H .

As a result, subgraph H is 1-guardable. \square

Example 3.4. Let G be a graph given in Figure 6 and $H = G[\{i, j, k, l\}]$ induced subgraph of G . Then we get $A = \{e, f, g, h\}$ and $B = i, j, k, l$. Since

$$|N_2(a) \cap A| = |N_2(b) \cap A| = |N_2(c) \cap A| = |N_2(d) \cap A| = 2$$

we find $k = 2$. Besides, for all $v \in A$ $B_v \neq \emptyset$ and the inequalities

$$2 = \max\{d(x, y) : x, y \in B\} \leq 2 = k$$

and

$$3 = \min\{d(v_1, v_2) : v_1, v_2 \in A\} \geq \max\{d(x, y) : x, y \in B\} = 2$$

are valid. Hence, by Theorem 3.3 we obtain that H is 1-guardable.

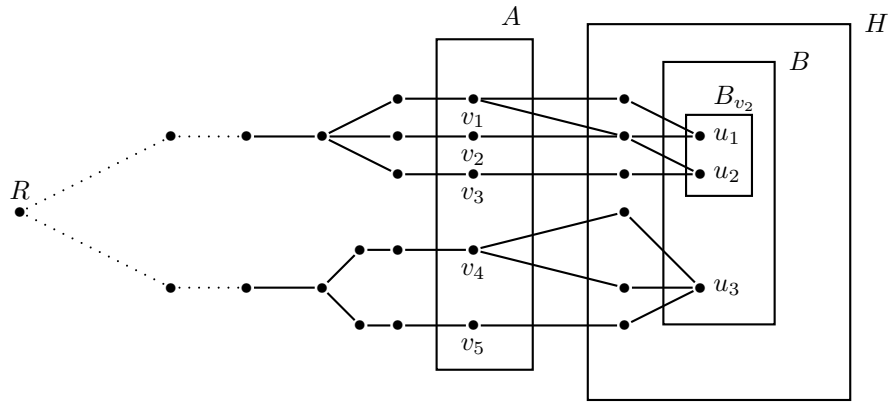

FIGURE 5. Figure that is given in proof of Teorem 3.3

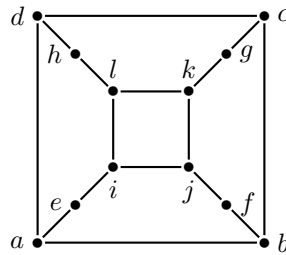

FIGURE 6. Graph G in Example 3.4

4. CONCLUSION

In this paper, we try to determine under what conditions the subgraph of a graph can be 1-guardable. Some special subgraphs of a graph was defined at first then was given the relations between these subgraphs. Some conditions were given with the help of lemmas and theorem in order for the subgraph to be 1-guardable. Finally, an example of a graph that verifies the theorem is given.

5. ACKNOWLEDGMENTS

The authors would like to thank the reviewers and editors of Journal of Universal Mathematics.

Funding

The authors declared that has not received any financial support for the research, authorship or publication of this study.

The Declaration of Conflict of Interest/ Common Interest

The authors declared that no conflict of interest or common interest

The Declaration of Ethics Committee Approval

This study does not be necessary ethical committee permission or any special permission.

The Declaration of Research and Publication Ethics

The authors declared that they comply with the scientific, ethical, and citation rules of Journal of Universal Mathematics in all processes of the study and that they do not make any falsification on the data collected. Besides, the author(s) declared that Journal of Universal Mathematics and its editorial board have no responsibility for any ethical violations that may be encountered and this study has not been evaluated in any academic publication environment other than Journal of Universal Mathematics.

REFERENCES

- [1] R. Nowakowski, P. Winkler, Vertex-to-Vertex Pursuit in a Graph, *Discrete Mathematics*, Vol.43, No.2-3, pp.235-239 (1983).
- [2] M. Aigner, M. Fromme, A Game of Cops and Robbers, *Discrete Applied Mathematics*, Vol.8, No.1, pp.1-12 (1984).
- [3] A. Berarducci, B. Intrigila, On the Cop Number of a Graph, *Advances in Applied Mathematics*, Vol.14, No.4, pp.389-403 (1993).
- [4] A. Bonato, R. Nowakowski, *The Game of Cops and Robbers on Graphs*, American Mathematical Society, Providence, RI (2011).
- [5] P. Frankl, Cops and Robbers in Graphs with Large Girth and Cayley-Graphs, *Discrete Applied Mathematics*, Vol.17, No.3, pp.301-305 (1987).
- [6] E. Chiniforooshan, A Better Bound for the Cop Number of General Graphs, *Journal of Graph Theory*, Vol.58, No.1, pp.45-48 (2008).
- [7] L. Lu, X. Peng, On Meyniel's Conjecture of the cop Number, *Journal of Graph Theory*, Vol.71, No.2, pp.192-205 (2012).
- [8] T. Ball, R. W. Bell, J. Guzman, On the Cop Number of Generalized Petersen Graphs, *Discrete Mathematics* (2016).
- [9] A. Quilliot, A Retraction Problem on Graph Theory, *Discrete Mathematics*, Vol.54, pp.61-71 (1985).
- [10] A. Bonato, P. Golovach, G. Hahn, J. Kratochvil, The Capture Time of a Graph, *Discrete Mathematics*, Vol.309, No.18,SI, pp.5588-5595 (2009).
- [11] T. Gavenciak, Cop-win Graphs with Maximum Capture-time, *Discrete Mathematics*, Vol.310, No.10-11, pp.1557-1563 (2010).
- [12] L. Lu, Z. Wang, A Note on 1-Guardable Graphs in the Cops and Robber Game, *Arxiv*, eprint-1804.02802, math.Co (2018).

(Nazlıcan Çakmak) VOCATIONAL SCHOOL OF TECHNICAL SCIENCES, BASKENT UNIVERSITY,
06790 ANKARA, TURKEY

Email address: nazlicancakmak@baskent.edu.tr

(Emrah Akyar) DEPARTMENT OF MATHEMATICS ESKISEHIR TECHNICAL UNIVERSITY 26470 ES-
KISEHIR, TURKEY

Email address: eakyar@eskisehir.edu.tr