



Otomatik Araçlar İçin Radyofar Temelli Yön Bulma

Beacon Based Navigation for Automized Vehicles

Mert SUBAŞIAY^{1*}, Tuğba Selcen NAVRUZ¹

¹ Gazi University, Faculty of Engineering, Electrical and Electronics Engineering, Ankara, Turkey

Başvuru/Received: 10/11/2018

Kabul/Accepted: 13/12/2018

Son Versiyon/Final Version: 31/12/2018

Öz

Bu makalede günümüzde yaygın bir çalışma alanı olan insansız veya otomatik araçlar için geliştirilmiş bir yön bulma sistemi sunulmuştur. Amaç, GPS(Global Positioning System) sisteminin çalışmadığı veya hatalı çalıştığı noktalarda yön bulmayı sağlamaktır. Sunulan sistem temel olarak yol boyunca arka arkaya dizilmiş radyofarlardan aldığı açı bilgisi ile yön bulma üzerine kuruludur. Otomatik araçlarda, şehir içinde veya şehirlerarası yön bulmada, GPS'e destek olma potansiyeline sahiptir. Sistemin avantajları ise; hızlı bir şekilde araç otomasyonu sağlayabilmesi ve ortam koşullarından oldukça az etkilenmesidir. Kullanıldığı mesafeye göre, GPS'den daha ucuza daha hassas otomasyon sağlayabilmektedir. Yapılan MATLAB benzetimlerinin sonuçları sistemin uygulanabilir ve geliştirilebilir olduğunu kanıtlar niteliktedir. Benzetimlerde hem düz yolda hem de virajlı yollarda; bu sistemle, yüksek hassasiyetle aracın şeridini korunduğu sonucuna ulaşılmıştır.

Anahtar Kelimeler

“Navigasyon, Yön bulma, İnsansız araçlar, Otomize araçlar, Radyofar”

Abstract

This paper is about a navigation system for unmanned or automized vehicles which is one of the important issues nowadays. We propose a system that solves the issue about navigating where GPS system does not work or cannot reach to enough accuracy. Proposed system basically consists of setting beacons alongside the road and navigate according to bearing angles of those beacons. The system can assist vehicles that are navigated with GPS, in cities or between cities. The advantages of the proposed system are, providing quick automation and being less sensitive to environmental conditions. Proposed system can provide much cheaper maintenance and more sensitive automation than GPS when it is assisted by a map in its data base. The MATLAB simulations of the system prove that system is practicable and developable. In simulations it is verified that; with this system, vehicle can keep its line with high precision.

Key Words

“Navigation, Direction finding, Unmanned vehicles, Automized vehicles, Beacon”

1. INTRODUCTION

Nowadays big companies such as Mercedes, Tesla and Google are working on automatized vehicles. Each of these companies has their own unique systems but they are using similar hardware and GPS (Global Positioning System) technology. However there is no commercially full automatic car due to lack of system reliability. Companies integrate these systems to their cars but none of them guarantee a safe drive. So it is advised that even when using auto pilot, driver must not let go of steering wheel.

Intuitively, RFID-ANS (Radio Frequency Identification Assisted Navigation System) complements to the current GPS navigation system when GPS signals are not available (such as in tunnels) or when the GPS position is ambiguous to a vehicle (such as at cloverleaf intersections). But in practice, GPS does not provide sufficient information for navigation due to its low positioning accuracy (5 to 7 meters). Moreover, even combined with map-matching technologies, GPS still cannot achieve lane level positioning and cannot provide information regarding the traffic direction in the current lane. Nevertheless, these information are necessary to prevent vehicles from entering a wrong way when roads are under construction or lanes are temporarily borrowed by the traffic along a different direction (Cheng vd., 2012: 1).

When first GPS system worked operationally it had 100 meter of tolerance. After receiver adjustments, this tolerance reduced to 20 meters. DGPS (Differential GPS) has much lower tolerance and high accuracy. However the ideal conditions of DGPS depend on several important variables such as ionosphere effects, satellite positions and time differences. In most of the navigation systems those use GPS, system malfunction becomes due to non-homogeneity of environment and unknown object encounter while transferring data. For example GPS cannot be used for underground works and inside the mines, moreover some buildings block the GPS signals. The applications including RFID are mostly designed for indoor navigation. In RFID systems, indoor navigation is achieved by using methods of range finding, object defining and mapping. Due to nature of RFID all of these systems include data transmission. But this makes it dependent to a number of environmental factors. Besides these systems cannot be adapted to outdoor applications (Chris Tralie; Tsukiyama, 2011: 2)

In the long range navigation applications with RFID for cars and trucks, tags are placed under road and used not only for navigation but also for providing information about road. The disadvantage of this system are, the requirement of tags to be placed while road is being built and it requires huge number of tags (Jing vd., 2016: 2). In 2016, Apple proposed a beacon based navigation in one of its patent but this system also transmits data so it depends on environmental variables too (Varoglu, 2016). Proposed navigation system in this paper basically consists of marking road with beacons. Vehicle finds its path by measuring angles of beacons while taking its current heading direction as reference. While vehicle progresses through road it updates beacon in interest. Also with some extra beacons vehicle can be informed about changes in road (For example number of lanes or width of the road). A phased array antenna can be utilized to find the angles of beacons.

An antenna converts bound circuit fields into propagating electromagnetic waves and, by reciprocity, collects power from passing electromagnetic waves. Maxwell's equations predict that any time-varying electric or magnetic field produces the opposite field and forms an electromagnetic wave. The wave has two fields oriented orthogonally, and it propagates in the direction normal to the plane defined by the perpendicular electric and magnetic fields. The electric field, the magnetic field, and the direction of propagation form a right-handed coordinate system. The propagating wave field intensity decreases by $1/R$ away from the source, whereas a static field drops off by $1/R^2$. Any circuit with time-varying fields has the capability of radiating to some extent. We consider only time-harmonic fields and use phasor notation with time dependence $e^{j\omega t}$. An outward-propagating wave is given by $e^{-j(kR - \omega t)}$, where k , the wave number, is given by $2\pi/\lambda$. λ is the wavelength of the wave given by c/f , where c is the velocity of light (3×10^8 m/s in free space) and f is the frequency. Increasing the distance from the source decreases the phase of the wave (Milligan, 2005: 1).

Suppose that a wave approaches with an angle to the axis of an array located on the z axis (Figure 1). The wave reaches the top element first and progresses down the array in succession. If the signals are added directly, they will cancel each other to some extent because they have a progression of phases.

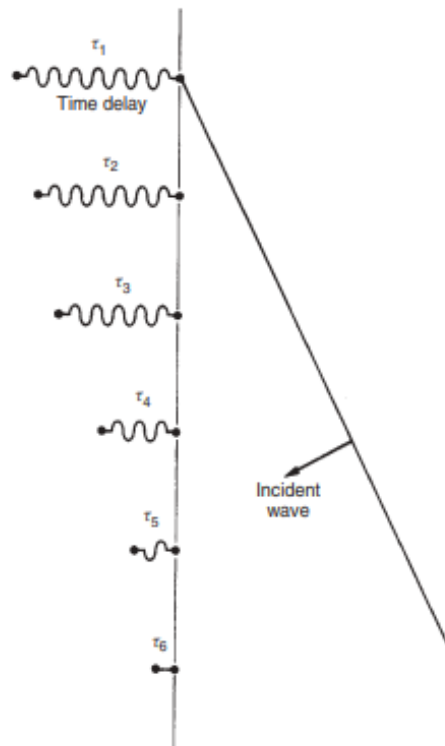

Figure 1: Linear array scanned with time-delay networks

Figure 1 shows the results of adding a series of time delays to equalize the path lengths in the lines where the position z_i along the axis determines the time delay τ_i for incident angle θ_0 :

$$\tau_i = z_i / c \cos (\theta_0 + \tau_0) \tag{1}$$

and velocity of light c . We add an arbitrary time delay τ_0 to keep all time delays, τ_i , positive. This feed network is frequency independent, as we vary the progression of time delays to scan the beam. Phase shifters replace the time-delay networks in phased arrays. They provide equivalent beam scanning at a single frequency. To scan to an angle θ_0 , the required phase shift is

$$(-2\pi/\lambda) z \cos(\theta_0) \text{ modulo } 2\pi \text{ (rad)} \tag{2}$$

$$(-360^\circ/\lambda) z \cos(\theta_0) \text{ modulo } 360^\circ \text{ (deg)} \tag{3}$$

for elements located on the z -axis. The phase factor on each element of a general space array is

$$e^{(-jk_0 \cdot r)} \tag{4}$$

where

$$k_0 = 2\pi \lambda (\sin \theta_0 \cos \phi_0 x^\wedge + \sin \theta_0 \sin \phi_0 y^\wedge + \cos \theta_0 z^\wedge) \tag{5}$$

is the vector propagation constant in the direction of the beam and r is the element location (Milligan, 2005: 117).

An array sensor system has multiple sensors distributed in space. This array configuration provides spatial samplings of the single sensor in signal reception and parameter estimation. Its superior spatial resolution provides a means to estimate the direction of arrival (DOA) of multiple signals. A sensor array also has applications in interference rejection, electronic steering, multi-beam forming, etc. This technology is now widely used in communications, radar, sonar, seismology, radio astronomy and so on (Grice vd., 2007).

DOA of wideband signals can be effectively estimated by using Space Time Adaptive Processor (STAP). STAP is the combination of space and time processing, thus it demands a higher processing power. Best performance of STAP is by choosing the reference signal as the center data of the FIR filter from the sensor at the origin (Grice vd., 2007: 1-2).

One of the big advantages of proposed system is that it does not require transferring data. The other big advantage of the system is that it does not depend on the amount of power of the incoming signal. Vehicle can receive the incoming electromagnetic wave from beacons with a phased array antenna and calculate angles of beacons. Therefore the proposed system is independent of most of the environmental factors since phased array antenna finds angle by phase difference. Beacons can be passive RFID tags and they can be energized by a transmitter on the vehicle. This will save us from energizing beacons by wire.

2. PROPOSED SYSTEM

The aim of designed system is to create an alternative to GPS system when GPS signal is not available or when it cannot provide enough accuracy. For example, RFID navigation can be used to transfer ores from a mine automatically or to navigate on Mars where GPS signal is unavailable. Also sand storms may cause a malfunction on GPS navigation since signals coming from outer atmosphere. Proposed system can assist in these kinds of cases. The principle of proposed system is navigating without an operator, using beacons alongside the road.

Here are important details:

- Beacons must be placed at the edge of the road as seen in Fig.2
- If road is curved, the line between beacon pairs, must intersect on the center of curve as seen from Fig.3.
- When road width changes, vehicle must be informed.

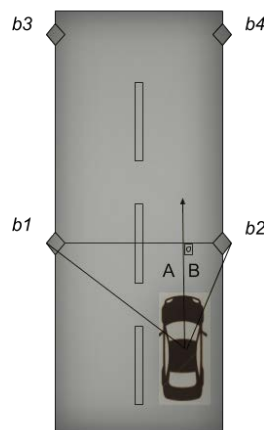

Figure 2: Straight road navigation

Placed beacons transmit electromagnetic wave omnidirectionally and none of them transfer data. A phased array antenna on vehicle can calculate angles of beacons. If beacon frequencies are different from each other, they can be identified easily. On the other hand beacons can broadcast with same frequency but they must not be placed inside their ranges.

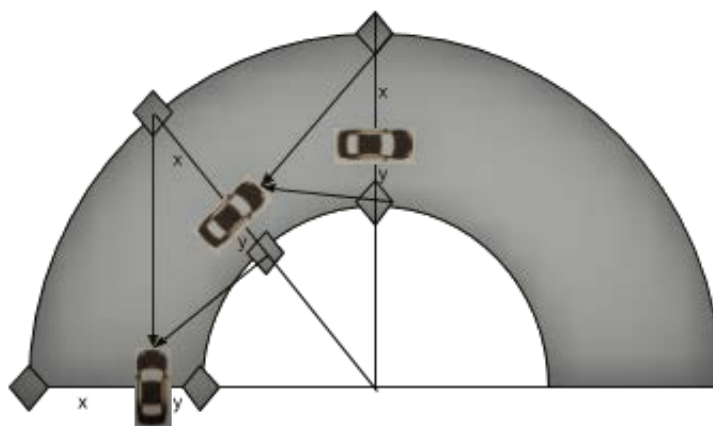

Figure 3: System implemented to a curved road

After calculation of beacon angles, system calculates angle of curve. If road is straight it can be identified with this calculation. Here the reference angle is the direction of vehicle. For example in Figure 2 A and B are angles of incidence. One of the system input is the ratio between the right side and left side of road widths (basically which line is used on road). If this information is satisfied to proposed system, vehicle can navigate on straight and curved roads without losing track of its line, Vehicle must be informed if road width changes since the input is the ratio of widths. This can be satisfied with different kinds of sensors or a beacon can be placed that transmits road width. The output of the system is angle of curved road and distance to the center of curve. These values are enough to navigate through a curved or straight road without losing line. When sum of both beacon

angles is equal to 180 degrees following beacon signals are taken into account and continues until no signal is received. System calculates several arithmetical and trigonometric equations at background.

Assume that beacon angles are 'b' and 'a' as seen in Figure 4.

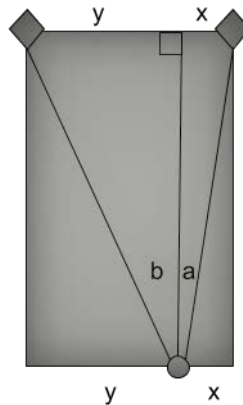

Figure 4: Angles of beacons on straight road

Also assume that line ratio is 'x / y' and the vehicles distance to line between beacons is 'h'.

In this case:

$$\tan(a) = x / h \tag{6}$$

$$y / \tan(b) = h \tag{7}$$

If h replaced in Eq. (6) as in Eq. (7)

$$\tan(a) = \tan(b) * x / y \tag{8}$$

From Eq. (8) the result is obtained as zero:

$$\tan(a) - \tan(b) * x / y = 0 \tag{9}$$

If the above equation is not equal to zero it means that vehicle is losing its line. On a straight road this equation shall stay equal to zero. If it's not then it means road ahead is curved. In this case following algorithm works:

Width ratio 'B / C' is given as input and distance to center of road from the edge of road is 'A'. Here beacon angles are 'b' and 'a' similar to straight road. So it means that complementary angles of 'b' and 'a' are 't' and 'g' respectively, when vehicle direction is taken as reference. In this case if we use triangle angle rules and sine theorem:

$$\sin(t) / (A+B+C) = \sin(t-m) / (B+A) \tag{10}$$

$$\sin(g) / A = \sin(g + m) / (B+A) \tag{11}$$

'A' is obtained as below from Eq. (11):

$$A = (B*\sin(g)) / (\sin(g + m) - \sin(g)) \tag{11}$$

If Eq. (10) is adjusted as this:

$$\sin(t) / \sin (t-m) = 1 + (C / (B+A)) \tag{12}$$

In Eq. (12) 'A' can be replaced as in the Eq. (11). After 'A' is replaced and trigonometric conversion formulas are used, a quartic equation is derived that depends on cosine (m). With this equation 'm' can be derived which is curve of road. After curve is found, with Eq. 11, 'A' also can be derived which is distance to center of curve.

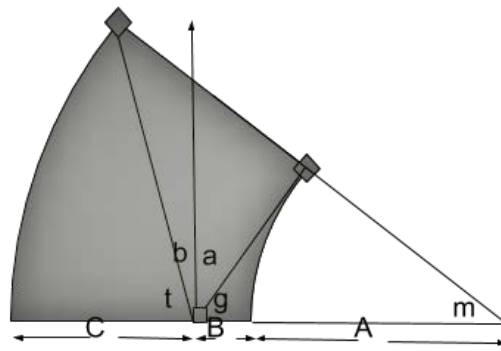

Figure 5: Angles on curved road

As seen in Figure 6 vehicle 'V2' can block signal broadcasting from 'b1' and cause malfunction for vehicle 'V2' navigation. To prevent other vehicles from blocking the signal, beacons can be placed higher than height of a truck. Height of the beacon only effects range of broadcast. Navigation algorithm does not depends on the height of the beacon since phased array antenna can be design as it can only detect horizontal incoming signal angle.

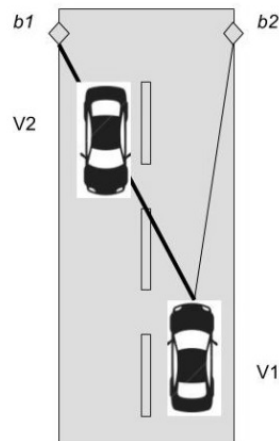

Figure 6: Signal blocked by other vehicle

Broadcasting signal can be reflected by ground and other vehicles as seen in Figure 7 and Figure 8. The main difference between reflected signal and broadcasting signal is amplitude and direction.

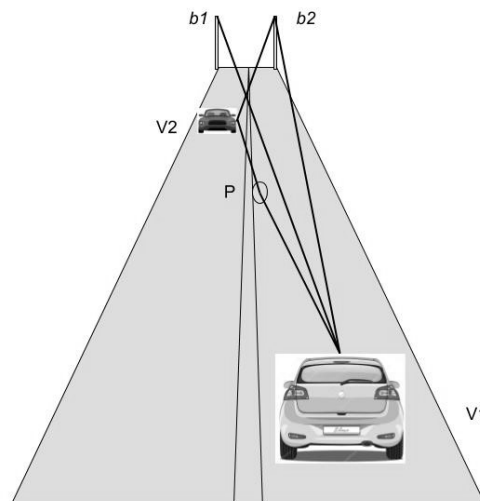

Figure 7: Signal reflection from other vehicle

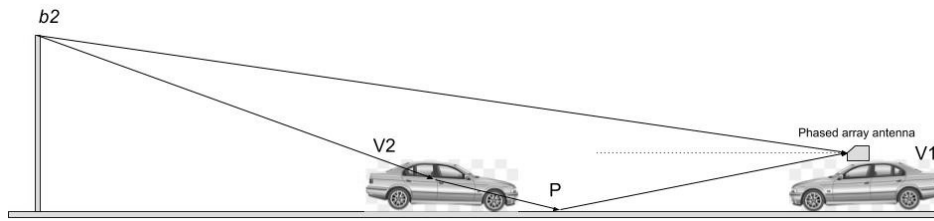

Figure 8: Signal reflection from other vehicle

Reflected signal may not reach phased array antenna due to attenuation or frequency distortions but in case, antenna can be designed as it will not receive signals coming from bottom of the antenna. Reflected signal will be coming from bottom of the vehicle since beacon transmits signal from a higher attitude. So broadcasting signal can be differentiated from reflected signal. To eliminate signals coming from bottom, a metal sheet can be placed under the antenna or antenna can be placed at the back of the vehicle (as seen in Figure 9) since most of the vehicles top is covered with metal.

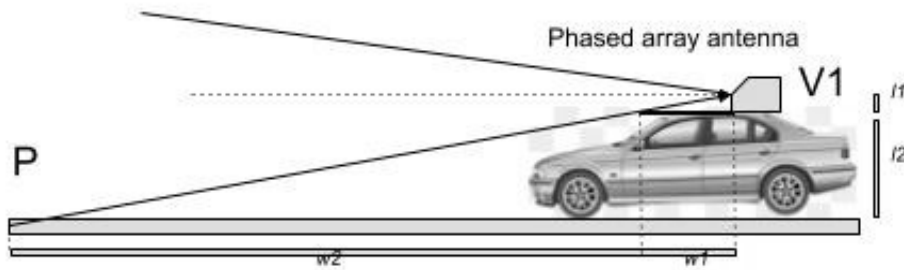

Figure 9: Phased array antenna design

If we calculate how far reflected signal can be blocked by cars top metal sheet:

$$(l1 + l2) / l1 = (w1 + w2) / w1 \tag{13}$$

In Eq. 13 we are looking for $(w1 + w2)$ which is how far reflected signal should be coming from to reach the antenna. If we assume average height of the vehicle as 1.5 meters, height of antenna as 0.1 meters and top sheet length as 3 meters we find:

$$(0.1 + 1.5) / 0.1 = (w1 + w2) / 3 \tag{14}$$

$$(w1 + w2) = 48 \text{ meters} \tag{15}$$

3. SIMULATION AND DISCUSSION

The system was simulated with MATLAB. In simulations, the direction that the vehicle traveled was assumed as the reference angle, and the angle to the point where the beacons were located was given as input to the system. These inputs correspond to the 't' and 'g' angles shown in Figure 5. Another input is the ratio of 'C' and 'B' distances.

After determining the inputs, the system is programmed to track the direction of the vehicle to be updated depending on the angle of the beacons. As shown in Figure 10, Figure 11, Figure 12, the vehicle can keep its route without leaving the line, according to the angle information taken from the beacons located at the sides of the road respectively.

An important problem that should be solved in the system is the location of the beacons. The arrangement of the beacon locations depends on the broadcasting frequency of the beacons. They may broadcast at the same frequency or at different frequencies. When the same frequency broadcasting is considered, there is a possibility that the vehicle will confuse from which beacon the signals is taken. So it is necessary to make a selection according to the arrival angle (a and b angles in Figure 5) of the signals. It is highly likely that the algorithm in the vehicle will mix the places of the beacons where the intersection of broadcast fields of radio stations is intense (for example, in bends and intersections). Therefore, the distance of the beacons should be selected considering the intersection of the broadcast areas.

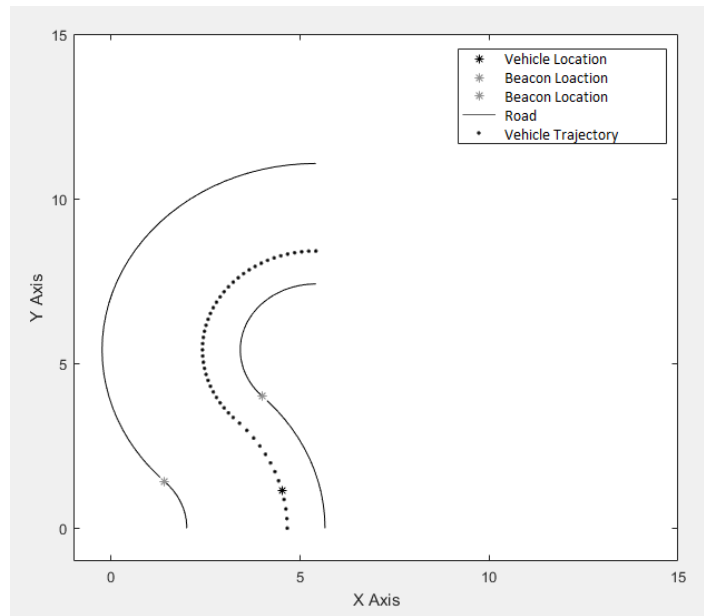

Figure 10: Vehicle status on T = 1 instance

On the other hand, if we consider the design of a different frequency broadcast radio, the intersection of the broadcast ranges of the beacons is not a problem. If at least 3 different frequencies are selected and are assigned periodically along the way to the beacons in pairs, the intersection of the beacons are blocked on the straight path. However, more frequencies may be needed during bends and intersections. If a design is to be selected in such a manner in the beacons, the phased array antenna(s) on the vehicle must be considered in accordance with this design.

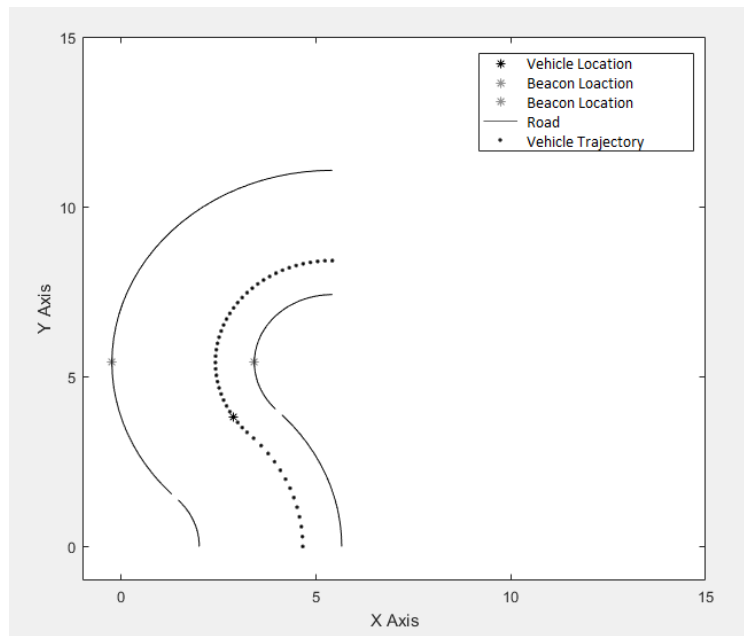

Figure 11: Vehicle status on T = 2 instance

An advantage of the different frequency broadcast beacon design is that if one of the beacon pairs fails, the vehicle may notice that it is malfunctioning and the path can be estimated with another algorithm. In this way the design is more advantageous, but it has a wider area in the frequency band. At the same time, phased array antenna(s) make the design more challenging.

Two different simulations have been made, one for curved road and other one for an intersection. Intersection results can be seen in Figure 13, Figure 14, Figure 15 and Figure 16. To eliminate confusion of beacons in intersection simulation, additional beacons has been placed to the corners. In the implementation; beacons were placed at the bends at intervals of 45 degrees in curved road simulation. According to the results of the simulation, when it is accepted as (0,0) point and 0 degree as references, vehicle arrived the place where supposed to have arrived with a faulty of 0,00074% and reached to 1,4694 degrees fault in direction.

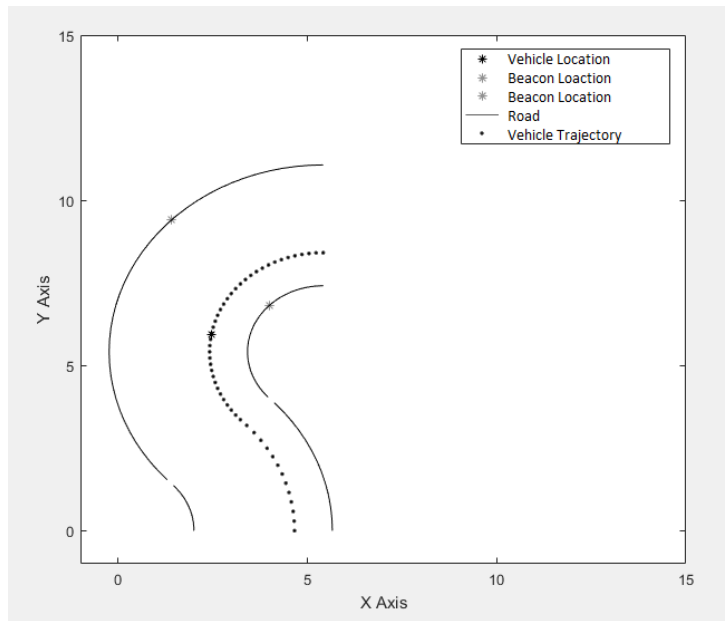

Figure 12: Vehicle status on T = 3 instance

The reason for the resulting error is due to the fact that sinus and cosine functions are used while the locations of the beacons are being written. Also some of the numbers are rounded.

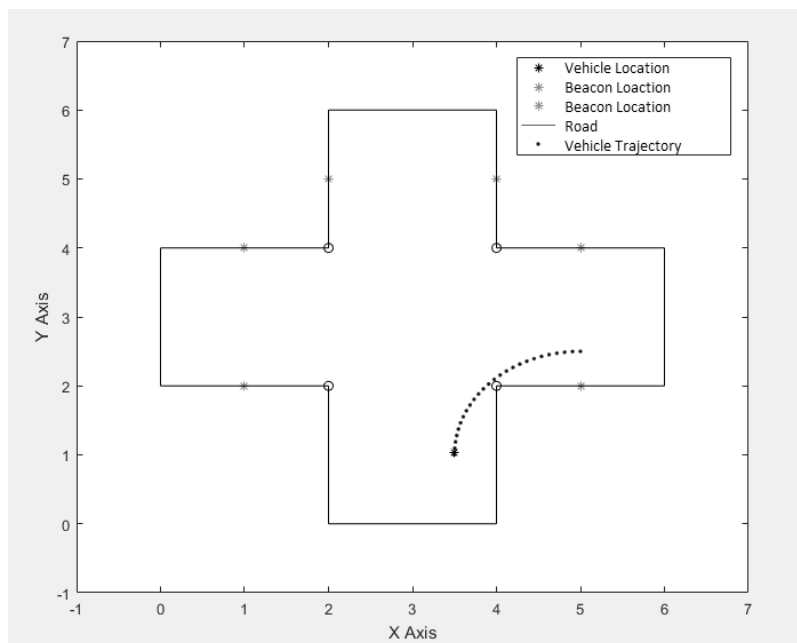

Figure 13: Vehicle status on T = 1 instance in intersection

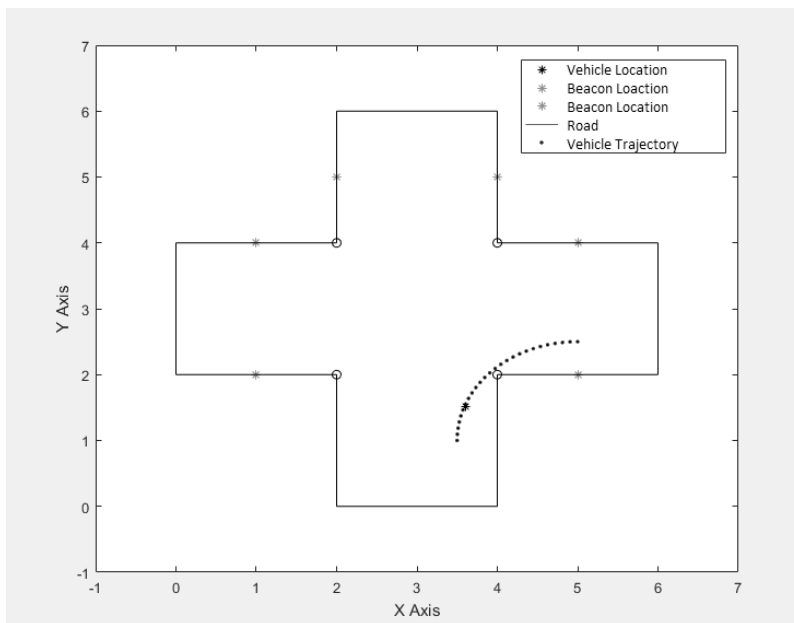

Figure 14: Vehicle status on T = 2 instance in intersection

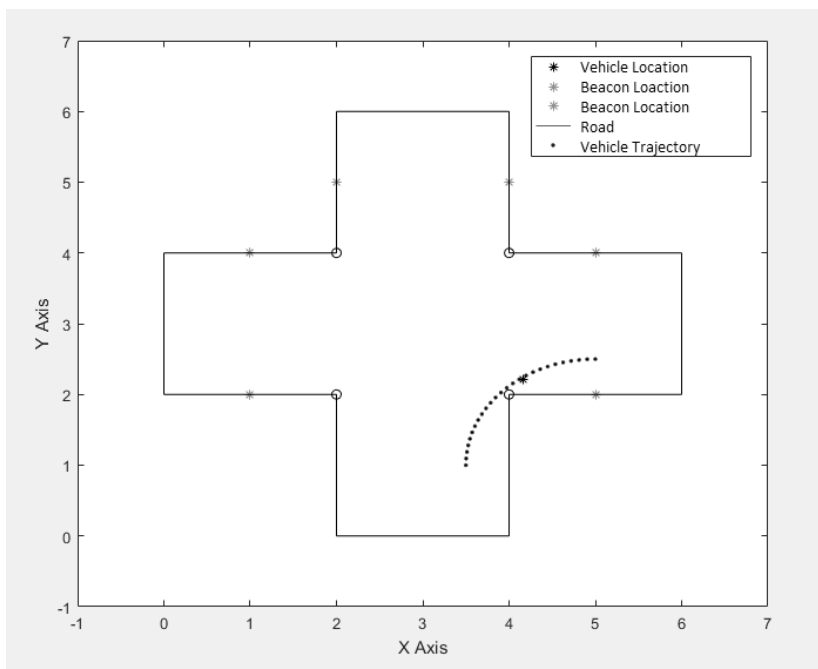

Figure 15: Vehicle status on T = 3 instance in intersection

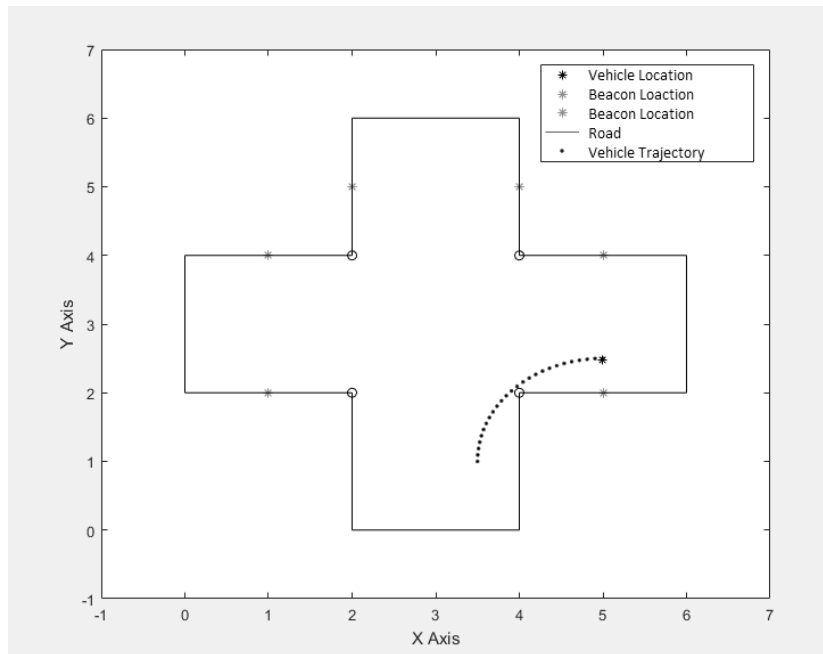

Figure 16: Vehicle status on T = 4 instance on intersection

4. CONCLUSION

Simulations made with MATLAB are evidence of the correctness of the algorithm and indicate that the system can be further improved. Electromagnetic transmission and antenna models also will be analyzed and added to simulation in future researches.

The disadvantage of the system is; along the road, the width of the road must be determined and reported to the system on the vehicle. This can be done with many different sensors, or with another beacon that indicates that the width of the road has changed. Also other vehicles and buildings may reflect the broadcasting signal and cause malfunction in navigation.

If we compare this to a satellite-based system (GPS, Galileo ...), the cost of constructing a satellite starts at \$ 100 million, and its orbit placement cost ranges from \$ 10 million to \$ 400 million (Brown and Harris, 2000: 11). A glitch that can occur during launch can cause the rocket to explode and cause these operations to be repeated (constructing and launching the satellite). Moreover, any electronic or software failure that may occur in the satellite after it has been placed in the orbit, may cause it to construct and launch again in a similar way. If you consider that satellite-based systems do not use a single satellite, the risk of cost, malfunction and error increases. In the proposed system, in case of any malfunction, the whole system does not collapse and the defective part can be repaired alone.

The weakness of the proposed system compared to the satellite-based systems is that the system needs to be laid separately on all roads. If the system is developed on its own, it can provide direction finding or it can be combined with GPS to increase the accuracy rate of GPS. In the future researches combining system with a local map will be carried out. Simulating with a map would be more accurate and realistic.

REFERENCES

Brown, G., Harris, W., (2000), *How Satellites Work*, retrieved from <https://science.howstuffworks.com/satellite.htm> on 4th July 2018.

Cheng, W., Cheng, X., Song, M., Chen, B., Zhao, W., (2012), On the Design and Deployment of RFID Assisted Navigation Systems for VANETs, *IEEE TRANSACTIONS ON PARALLEL AND DISTRIBUTED SYSTEMS*, 23(7), 1-1.

Grice, M., Rodenkirch, J., Yakovle, A., Hwang, H., Aliyazicioglu, Z., Lee, A., (2007), Direction of Arrival Estimation using Advanced Signal Processing, *California State Polytechnic University, Pomona*, 1-2

Jing, T., Wei, X., Cheng, W., Guan, M., Ma, L., Huo, Y., and Cheng, X., (2016), An Efficient Scheme for Tag Information Update in RFID Systems on Roads, *IEEE TRANSACTIONS ON VEHICULAR TECHNOLOGY*, 65(4), 1-2.

Milligan, T., (2005) *Modern Antenna Design, Second Edition* (p. 1-117), New Jersey: John Wiley & Sons, Inc..

Tralie, C., Robotic Navigation with RFID Waypoints, *Duke University, Electrical and Computer Engineering.*

Tsukiyama, T., (2011), RFID Based Navigation System for Indoor Mobile Robots, *Proceedings of the 18th World Congress The International Federation of Automatic Control Milano (Italy)*, 1-2.

Varoglu D., (2016), System with wireless messages to enhance location accuracy, *U.S. Patent and Trademark Office, Apple's U.S. Patent No. 9,344,989.*