



Soil erodibility evaluation by splash cups under the simulated rainfalls

Melis Özge Pınar ^{a,*}, Günay Erpul ^b

^a Transitional Zone Agricultural Research Institute, 26002 Eskisehir, Turkey

^b Ankara University, Faculty of Agriculture, Department of Soil Science and Plant Nutrition, 06110 Ankara, Turkey

Abstract

Soil erodibility is an important parameter to determine the sensibility of soil to the erosion and there are many methods to specify the erodibility. Until today, many methods were improved and the "Universal Soil Loss Equation (USLE), which has the most common use in worldwide, is one of them. In this prediction technology, the soil susceptibility to the water erosion is represented by a multiplier factor together with those for climate, topography, vegetation and conservation practices. This study aimed to determine a soil erodibility factor by the laboratory simulated rainfall tests under the specified kinetic energy and rainfall intensity values using the splash cups. For test soils, a total of 256 surface samples were taken from the fallow-crop system in the Asartepi Dam Basin and the splash erosion rate was found with the units compatible with the USLE. However, since the USLE predicts soil losses from not only splash erosion but also sheet and rill erosions, the measured splash values should be mathematically related to the erodibility equations commonly employed in the model in order to meet the model requirement.

Keywords: Splash erosion, rainfall simulation, energy flow, soil erodibility

Article Info

Received : 06.11.2011

Accepted : 04.06.2012

© 2012 Federation of Eurasian Soil Science Societies. All rights reserved

Introduction

Until today, some researchers tried to make relations between soil characteristics and physical rainfall parameters to explain the soil erodibility process. Hence, there are many studies about the relationships between soil erodibility and rainfall (Ellison, 1947; Young and Wiersma, 1973; Morgan, 1978; Poesen and Savat, 1981; Ghadiri and Payne, 1981, 1986, 1988; Poesen and Torri, 1988; Sharma and Gupta, 1989; Salles and Poesen, 2000; Ghadiri 2004). Bubenzer and Jones (1971) studied on the sensibility of soil to the splash erosion under the different rainfall intensities by using different drop size and drop velocity distribution. Kinnell (1973) related soil loss to the rainfall intensity. Park et al., (1983) and McIsaac (1990) calculated the rainfall energy with the rainfall intensity distributions. A study underlying the mathematical correlation between erosion and rainfall physics was done by Meyer (1981). After this, Park et al., (1983) and Gilley and Finkner (1985) showed that physical impact parameters (size, impact frequency and impact velocity) and splash erosion rates of rainfall were closely linked. McIsaac (1990) suggested rainfall intensity (I) and kinetic energy (KE) equations by using drop size distribution of rainfalls for any area. Especially, Gilley and Finkner (1985) intended to determine functionality of the erodibility equations statistically, defining an erodibility equation by using raindrops at terminal velocity and conclusively proposed a "rainfall detachment factor" under the natural conditions as a function of rainfall intensity. Another group of researchers developed a splash cup method to understand the sensibility of the soil surface to erosion and raindrop erodibility under either natural precipitations or simulated rainfalls. A raindrop threshold energy

* Corresponding author.

Transitional Zone Agricultural Research Institute, 26002 Eskisehir, Turkey

Tel.: +90 222 237 57 00

Fax: +90 222 237 57 02

ISSN: 2147-4249

E-mail address: melisozgepinar@gmail.com

value for the soil detachment was presented by [Sharma and Gupta \(1989\)](#), and then, an equation for the total rainfall KE was developed by [Sharma et al., \(1993\)](#). To explain the raindrop-induced interrill erosion processes, [Sharma et al., \(1995\)](#) used the approach of the USLE. Parallely, this research made an attempt to obtain the soil erodibility in the units of the USLE by the experimental splash cup technique.

Materials and Method

Study area

Asartepe dam basin is located in the catchment-area of the İlhan creek sub-basin in the Sakarya Basin, within the boundaries of the Ayaş district of the Ankara province, approximately 47 km northeast of Ankara in Turkey. The region has a semi-arid climate with the average annual precipitation of 350 mm and average temperature of the region is 11,9°C and ranges from -20,6 to 42 °C. A wide range of *Entisol* soils represents the study area, which is mostly sandy and shallow.

Study methods

Soil sampling

Soil samples were taken from an arable land under the fallow-crop system in the Asartepe Dam Basin. The grid-based 231 soil samples by a square-mesh method and 25 soil samples, totally 256 surface soil samples (0-10cm), were sampled systematically and randomly from a plot in the study area, respectively. The sizes of the sampling plot and grid sizes are 50 x 100m 5m x 5m (Figure 1), respectively.

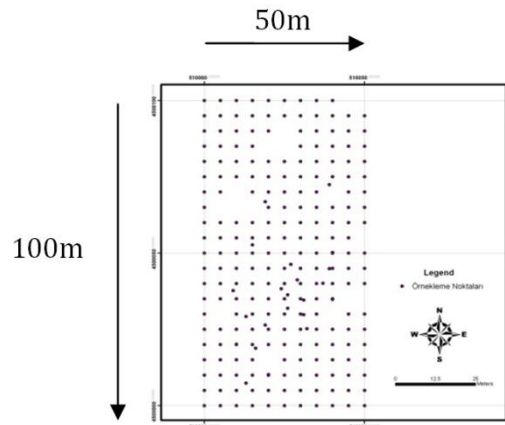

Figure 1. A combined grid-based and random sampling method

Determining rainfall energy and rainfall intensity

Rainfall simulations were carried out in the rainfall Simulation Unit at the Department of Soil Science and Plant Nutrition, Faculty of Agriculture, Ankara University ([Erpul and Çanga, 2001](#)).

To assess the rainfall energy, mass (m , kg), volume (V , m³) and surface area (A , m²) of the drops were calculated by the drop size (d , mm). For this study, these were $5,79 \times 10^{-5}$ kg, $5,79 \times 10^{-8}$ m³ and $1,809 \times 10^{-5}$ m², respectively, with a drop size of $4,8 \pm 0,07$ mm. The obtained KE for the uniform-sized raindrops falling 3m height was 1.491×10^{-3} kg m² s⁻² or "joule". Also, to determine the total KE flow of the artificial precipitation (E_T , J m⁻² s⁻¹), rainfall intensity measurements (I , m s⁻¹ or m³ m⁻² s⁻¹) or the determination of raindrop number (\mathcal{E} , # m⁻² s⁻¹) were implemented in the precipitation basin of the rainfall simulator.

Splash measurements

Soil splash tests by rainfall simulations were carried out with the air dried samples and the determination of moisture analysis were done for each soil sample. Bottom of the splash cups were covered with the porous fabric material for free drainage. Splash cups with the known weights and filled with the air-dried soils (W_{SK+HKT}) were exposed to the simulated rainfalls with the specified rainfall kinetic energy and rainfall intensity for 10 minutes (Figure 2a and 2b). After the rainfall simulations, the soil splash cups were dried in stoves for 24 hours at 120°C ($W_{(SK+WFKT)2}$, gr) and soil losses (W_T , gr) were calculated by Eq. (1):

$$W_T = W_{(SK+FKT)1} - W_{(SK+FKT)2} \quad (1)$$

$W_{(SK+FKT)1}$ and $W_{(SK+FKT)2}$ show oven-dry weights with the splash cups, respectively before and after rainfall. Soil loss (D , $\text{gr m}^{-2} \text{s}^{-1}$) from a splash cup surface per unit time was calculated by Eq. (2):

$$D = \frac{W_T}{A \cdot T} \quad (2)$$

A and T are splash cup surface area (m^2) and duration of rainfall simulation (s), respectively. In this research, the splash erosion was calculated with the USLE – K unit (Renard et al., 1997) (Eq. (3)):

$$K_s = \frac{D}{ET \cdot I} = \frac{\text{gm}^{-2}\text{s}^{-1}}{\text{Jm}^{-2}\text{s}^{-1} \cdot \text{ms}^{-1}} = \frac{\text{gm}^{-2}}{\text{Jm}^{-2} \cdot \text{ms}^{-1}} \quad (3)$$

K_s , E_T and I are respectively raindrop splash erosion, rainfall energy and rainfall intensity. Finally, the unit of Eq. [3] was converted into the USLE - K unit ([$\text{ton ha}^{-1}/(\text{MJ ha}^{-1} \text{mm h}^{-1})$]).

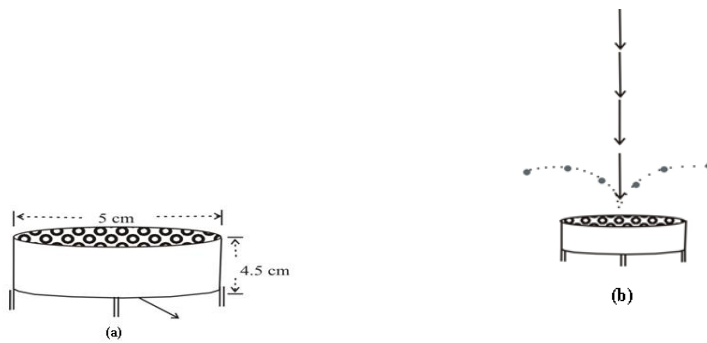

Figure 2. Splash cup and radial soil particle splash movement by vertical drop impact

Physical and chemical soil analyses

Aggregate stability, organic matter (OM), hydraulic conductivity (HC) and particle size distribution (PSD)

Aggregate stability analysis was conducted by the wet sieving method with only one diameter size suggested by Kemper and Rosenau (1986). Soil samples were sieved from the 1 mm diameter sized sieve and the soils which remained on the sieve were used for the analysis. The sieve of 0,5 mm diameter was used for the wet sieving and a stability index was calculated by Eq. (4).

$$AS = \frac{mb}{ma + mb} \quad (4)$$

AS: aggregate stability index; ma : the amount of the dispersed soil in water; and mb : the amount of the dispersed soil in sodium hexametaphosphate ($\text{pH} > 7$) or NaOH ($\text{pH} < 7$).

Before the rainfall simulations, the soil samples were air-dried without crushing in the laboratory in order to introduce the natural conditions of the soil samples and to be a reference point. Particle size distribution (Bouyoucus, 1951) and hydraulic conductivity (Klute et al., 1986) analyses were also performed. Organic material content of the soils was determined according to the revised Walkley - Black method (Walkey and Black, 1934; Walkley, 1947; Peech et al., 1947; Greweling and Peech 1960; Nelson and Sommers, 1982 and Tüzüner, 1990).

Statistical methods

Descriptive statistics was obtained using MINITAB 14.0. “Pearson correlation coefficient” (Eq. (5)) was calculated with a significance level of “ $p < 0,05$ ” among K_s and research soil properties.

$$\rho = \frac{\sum_{i=1}^n (x_i - \bar{x})(y_i - \bar{y})}{(n-1)s_x s_y} \quad (5)$$

\bar{x} , average sample for first variable; s_x , standard deviation for first variable; \bar{y} , average sample for second variable; s_y , standard deviation for second variable; n, number of sample.

Results and Discussion

The values of the descriptive statistics were given in Table 1. The descriptive statistics were done for particle size distribution (PSD), hydraulic conductivity (HC), organic material (OM), aggregate stability (AS) and K-value (K_s).

Table 1. The values of the descriptive statistics

Descriptive statistics	S	Si	C	HC	OM	AS	K_s
Average	38,70 ± 0,406	29,54 ± 0,318	31,87 ± 0,377	2,706 ± 0,142	0,06 ± 2,8019	0,44 ± 0,767	0,0282 ± 0,001
St. deviation	6,429	5,031	5,968	2,277	0,9624	4,88E-02	0,0151
Variance	41,327	25,308	35,615	5,184	0,9263	0,00285	0,0002
Coef. of Variation	16,61	17,03	18,72	84,13	34,35	6,94553	53,45
Min.	27,5	7,4	4,1	0,17	0,72	0,60134	0,01
Max.	96,6	56,5	56,2	13,84	8,04	0,93099	0,141
Skewness	3,17	0,63	-1,33	1,72	1,64	0,58	2,94
Kurtosis	25,32	5,4	6,68	3,46	5,01	0,692	14,82
KS*	0,075	0,064	0,103	0,036	0,065	0,662	0,1

*KS: Kolmogrov-Smirnov

“Pearson correlation coefficients” are shown in Table 2, there were no significant correlations between K_s – OM, K_s – AS and OM – AS with the original data set. However, when the original variable values were *ln*-transformed, better correlations were found (Table 2). The correlations of OM – AS ($P \leq 0,009^{**}$), OM – HC ($P \leq 0,000^{**}$) and OM – VFS ($P \leq 0,020^*$) were found statistically significant. Besides, AS – C ($P \leq 0,009^{**}$), AS – Si ($P \leq 0,038^*$) and AS – Si-VFS ($P \leq 0,024^*$) correlations were significant. Although HC did not show any significant correlation with C ($P \leq 0,406$) its correlations with S and Si were found significant and the values were $P \leq 0,000^{**}$ and $P \leq 0,022^*$ respectively. The corrected sand and silt values (S+VFS and Si-VFS, respectively) also indicated statistically significant relations with HC ($P \leq 0,001^{**}$ and $P \leq 0,026^*$, respectively).

There was no statistically significant correlation between K_s and other soil characteristics with the analysis carried out by both original data set and transformed data set although expected strongly. The reason was attributed to the fact that the soil samples were taken only from the arable land under the fallow-crop system in the Asartepe Dam Basin. Especially, in terms of OM and physical parameters soil sampling may not reveal enough variability, resulting in very confined data. Since OM content is closely associated with the land use type, most probably a satisfying range for statistical analysis to account for the diversity in the soils of the research area could not be obtained in data set. This situation particularly caused an inability to

generate a regression model between K_s and the tested soil physical characteristics. Only the correlation between K_s and VFS happened to be significant at the level of ($P \leq 0,088$).

Table 2. “Pearson correlation coefficients” between K_s and research soil properties using *ln-transformed data*

Variable	K_s	AS	OM	S	Si	C	HC	VFS	S+VFS	Si-VFS
K_s	1									
AS	0,209	1								
OM	0,237	0,009**	1							
S	0,711	0,266	0,946	1						
Si	0,995	0,038*	0,788	0,000**	1					
C	0,934	0,009**	0,552	0,000**	0,000**	1				
HC	0,421	0,792	0,000**	0,000**	0,022*	0,406	1			
VFS	0,088	0,510	0,020*	0,001**	0,007**	0,336	0,186	1		
S+VFS	0,818	0,294	0,672	0,000**	0,000**	0,000**	0,001**	0,625	1	
Si-VFS	0,792	0,024*	0,442	0,000**	0,000**	0,000**	0,026*	0,876	0,000**	1

K_s : RUSLE – K factor, AS: aggregate stability, OM: organic material, S: sand, Si: silt, C: clay, HC: hydraulic conductivity, VFS: very fine sand, S-VFS: revised sand, Si+VFS: revised silt, ** $P < 0,01$, * $P < 0,05$

Conclusion

The research indicated that the USLE-K factor could be experimentally obtained under the laboratory simulated rainfall conditions by the splash cup technique provided that it could be mathematically related to the erodibility equations, and once this is built with a wide range of data set, it could be more direct and easier method that those using the empirical equations with some independent soil property parameters.

Acknowledgment

This study has been conducted in the frame of the BAP project of the Ankara University “Updating Traditional Soil Map Units of Water Erosion with RUSLE – K and Determining the Uncertainty of Map Units by Geostatistics” (ref no: 08B4347003). The authors thank to Agricultural Eng. Sevinç MADENOĞLU to allow using soil samples from her Ph.D. study site and Research Assistant Selen Deviren SAYGIN for methodologically helping in the aggregate stability test and statistical analysis.

References

- Bouyoucos, G.J. 1951. A recalibration of hydrometer method for making mechanical analysis of soils. *Agronomy Journal* 43, 434-438.
- Bubbenzer, G.D., Jones Jr. B.A., 1971. Drop size and impact velocity effects on the detachment of soils under simulated rainfall. *Transactions of the ASAE* 14, 625-628
- Ellison, W.D. 1947. Soil erosion studies. *Agricultural Engineering* 28, 145-146.
- Erpul, G., Çanga, M.R., 2001 Toprak Erozyon Çalışmaları İçin Bir Yapay Yağmurlama Aletinin Tasarım Prensipleri ve Yapay Yağış Karakteristikleri. *Ankara Üniversitesi Ziraat Fakültesi Tarım Bilimleri Dergisi* 7(1), 75-83.
- Ghadiri, H. 2004. Crater formation in soils by raindrop impact. *Earth Surface Processes and Landforms* 29, 77-89.
- Ghadiri, H., Payne, D., 1981. Raindrop impact stress. *Journal of Soil Science* 32, 41-49.
- Ghadiri, H., Payne, D., 1986 The risk of leaving soil surface unprotected against falling rain. *Journal of Soil and Tillage Research* 8, 119 – 130.
- Ghadiri, H., Payne, D., 1988. The formation and characteristics of splash following raindrop impact on soil. *Journal of Soil Science* 39, 563-75.
- Gilley, J.E., Finkner, S.C., 1985. Estimating soil detachment caused by raindrop impact. *Transactions of the ASAE* 28, 140-146.
- Greweling, T., Peech, M., 1960. *Chemical soil tests*. Cornell Univ. Agric. Exp. Sta. Bull.960. Cornell University, USA.
- Kemper, W.D., Rosenau, R. C. 1986. Aggregate stability and size distribution. In: A. Klute (Ed.), *Methods of Soil Analysis*, Part 1. Agronomy Monographs, American Society of Agronomy, Madison, USA.
- Kinnell, P.I.A. 1973. The problem of assessing of erosive power of rainfall from meteorological observations. *Soil Science Society America Proceedings* 37, 617-621.
- Klute, A., Dirksen, C. 1986. Hydraulic conductivity and diffusivity laboratory methods. In: A. Klute (Ed.), *Methods of Soil Analysis*, Part 1. Agronomy Monographs, American Society of Agronomy, Madison, USA.

- Mclsaac, G.F. 1990. Apparent geographic and atmospheric influences on raindrop sizes and rainfall kinetic energy. *Journal Soil and Water Conservation* 45, 663-665.
- Meyer, L. D. 1981. How rainfall intensity affects inter-rill erosion. *Transactions of the ASAE* 24, 1472-1475.
- Morgan, R.P.C. 1978. Field studies of rainsplash erosion. *Earth Surface Processes* 3, 295– 299.
- Nelson, D.W., Sommers LE. 1982. Total Carbon, organic carbon, and organic matter. In: A. L. Page (Ed.), *Methods of soil analysis. Part 2. American Society of Agronomy, Madison, USA.*
- Park, S.W., Mitchell, J.K., Bubenzer, G.D., 1983. Rainfall Characteristics and Their Relation to Splash Erosion. *Transactions of the ASAE* 26, 795-804.
- Peech, M., Dean, L.A., Reed, J.F., 1947. *Methods of soil analysis for soil-fertility investigations: USDA. Circ. No. 757, pp. 7-12. USA.*
- Poesen, J., Savat, J., 1981. Detachment and transportation of Loose sediments by raindrop splash. *Catena* 8, 19-41.
- Poesen, J., Torri, D., 1988. The effect of cup size on splash detachment and transport measurements. Part II. Field measurements. *Catena* 12, 113–126.
- Renard, K.G., Foster, G.A., Weesies, D.A., McCool, D.K., Yoder, D.C., 1997. Predicting soil erosion by water: a guide to conservation planning with the revised universal soil loss equation (RUSLE). *Agriculture Handbook No. 703. USDA, Washington, DC.*
- Salles, C., Poesen, J., 2000. Rain properties controlling soil splash detachment. *Hydrological Processes* 14, 271-282.
- Sharma, P.P., Gupta, S.C., 1989. Sand Detachment by Single raindrops of varying kinetic energy and momentum. *Soil Science Society America Journal* 53, 1005-1010.
- Sharma, P.P., Gupta, S.C., Foster, G.R. 1993. Predicting Soil Detachment by raindrops. *Soil Science Society America Journal* 57, 674-680.
- Sharma, P.P., Gupta, S.C., Foster, G.R. 1995. Raindrop induced soil detachment and sediment transport :from interrill areas. *Soil Science Society America Journal* 59, 727-734.
- Walkley, A., Black, I.A., 1934. An examination of the effect of the degtjareff method for determining soil organic matter and a proposed modification of the chromic acid titration method. *Soil Science* 37, 29-38.
- Walkley, A., 1947. A critical examination of a rapid method for determining organic carbon in soils - effect of variations in digestion conditions and of inorganic soil constituents. *Soil Science* 63, 251-264.
- Young, R. A., Wiersma, J. L. 1973. The role of rainfall impact in soil detachment and transport. *Water Resources Research* 9, 1629–1636.
- Tüzüner, A., 1990. *Toprak ve Su Analiz Laboratuvarları El Kitabı*. Tarım Orman ve Köyişleri Bakanlığı Köy Hizmetleri Genel Müdürlüğü, Ankara.