

A NEW ADHESIVE COATING SOLUTION BASED ON A NATURAL ANIMAL POLYMER - PART I: PREDICTION OF BREAKING FORCE AND ELONGATION OF COATED COTTON YARNS

DOĞAL HAYVANSAL POLİMER ESASLI YENİ BİR BAĞLAYICI POLİMER- BÖLÜM I: KAPLAMALI PAMUK İPLİKLERİNİN KOPMA KUVVETİ VE UZAMASININ TAHMİNLENMESİ

Cozmin-Toma BUDA*, Daniela NEGRU, Dorin AVRAM

'Gheorghe Asachi' Technical University of Iasi, Department of Technology and Design of Textile Products, Iasi, Romania

Received: 20.06.2011

Accepted: 04.10.2011

ABSTRACT

In the first part of the article the influence of the coating material based on a natural animal polymer was investigated. Mathematical modeling and the optimization of the coated yarn's breaking force and elongation at break were presented by the rotatable central composition design, enabled by the factorial program order 22. The independent variables were X1 – concentration of natural animal polymer, which influences with his characteristics the yarn characteristics, X2 – tension force, which influences the way the solution will penetrate the structure of cotton yarn, and dependent variables Y1 – breaking force and Y2 – elongation at break of the coated cotton yarn. The properties of the coating material have to be found in the characteristics of the final coated yarn. Coating solution improves the coated yarn's characteristics with approximately 30% by forming an exterior layer on the yarn and also by getting into the yarn and connecting the fibers, so during the efforts that the yarn is subjected the coating material will take a part of stress.

Key Words: Natural animal polymer, Coating material, Tensile properties, Mathematical modelling, Optimization.

ÖZET

Makalenin ilk bölümünde, doğal hayvansal polimer esaslı kaplama malzemesinin etkisi incelenmiştir. Kaplamalı ipliklerin kopma kuvveti ve kopma uzamasının matematiksel modellenmesi ve optimizasyonu, 22faktöriyel düzeninde, döndürülebilir merkezi birleşik tasarımla gerçekleştirilmiştir. Bağımsız değişkenler, X1-iplik özelliklerini etkileyen, doğal hayvansal polimerin konsantrasyonu, X2-çözeltinin pamuk ipliğinin içine işleme şeklini etkileyen germe kuvveti ve bağımlı değişkenler kaplamalı pamuk ipliğinin Y1- kopma kuvveti ve Y2-kopma uzamasıdır. Kaplama malzemesinin özellikleri, son kaplanmış ipliğin özelliklerine aktarılmalıdır. Kaplama çözeltisi, iplik üzerinde bir harici tabaka olarak yer alarak ve ayrıca ipliğin içerisine girip, liflere bağlanarak kaplanmış ipliğin özelliklerini yaklaşık %30 iyileştirmektedir, böylece ipliğin kuvvete maruz kalması sırasında, kaplama malzemesi gerilimin bir kısmını üzerine almaktadır.

Anahtar Kelimeler: Doğal hayvansal polimer, Kaplama malzemesi, Gerilme özellikleri, Matematiksel modelleme, Optimizasyon.

* **Corresponding Author:** Cozmin Toma Buda, cozminbuda@gmail.com, Tel:+40 756 06 26 80 Fax:+40 232 23 04 91

1. INTRODUCTION

Today, many researchers are focusing on producing composite materials from natural fibers and natural resins and polymers. For example, Swedish researchers prepared a thermoset composite by using acrylate modified soybean oil resin and natural fibers, and the result was that it's possible to produce composite with high

mechanical properties, without adding a reactive comonomer like styrene to the resin (1). Hailin Lin, and Sundaram Gunasekaran obtained an adhesive by using cow blood (2), while Keyur P. Somani, and Sujata S. Kansara used polyurethane based on castor oil, for wood bonding (3).

W. Brockmann mentioned that natural adhesives including organic polymers

obtained from bones and animal skin have the advantage that they are biodegradable (4). Animal polymers are protein colloid glues. Proteins are organic compounds made of amino-acids arranged in a linear chain and folded into a globular form. The amino-acids in a polymer chain are joined together by the peptide bonds between the carboxyl and amino groups of

adjacent amino acid residues and colloid, a type of chemical mixture in which one substance is dispersed evenly throughout another. The particles of the dispersed substance are only suspended in the mixture, unlike in a solution, in which they are completely dissolved. This occurs because the particles in a colloid are larger than the ones in a solution – small enough to be dispersed evenly and maintain a homogeneous appearance, but large enough to scatter light and not dissolve. Because of this dispersal, some colloids have the appearance of solutions. A colloidal system consists of two separate phases: a dispersed phase (or internal phase) and a continuous phase (or dispersion medium). A colloidal system may be solid, liquid, or gaseous. In all animal glue production, the degreased raw material is subjected to the basic reaction of hydrolysis of collagen, a multiple helical chain protein: the rate of this hydrolysis increases with temperature and stronger acid or alkaline conditions. Hide glues are usually made through an acid process. The production conditions are designed to break down the collagen, but they retain large molecules in the resulting soluble proteins. The resulting dilute protein solutions are concentrated by evaporation and then gelled by cooling (5).

Production of animal glue is considered environmentally “friendly”, since it involves conversion of unpleasant waste into useful products, but an economic operation depends on satisfactory disposal of residues: some of these are used as slow release

nitrogenous fertilizers.

2. MATERIAL AND METHOD

For optimization of the breaking force and elongation, the coated cotton yarns were produced using the laboratory installation, presented in Figure 1. In this experiment 13 different types of coated cotton yarn were obtained accordingly with the experimental matrix. This coated yarns were tested on the dynamometer to establish the breaking force and elongation for each type of coated cotton yarn and this results were introduced in the optimization programme with the purpose of establishing the optimum values for breaking force and elongation and also to investigate if the properties of the coating material are found in the characteristics of the final coated yarn.

2.1. Experimental Conditions

The breaking force was tested by using the dynamometer produced by SDL ATLAS, H5KT. The tests were made according to the standard ISO 2062, breaking force of the yarns. 50 samples were tested for each experiment of the rotatable central composition program.

The experimental data were obtained by using a program for statistical processing of data, TEXPRO 2, developed by a research team from the Textile Faculty of Iasi, Romania. The rotatable central composition program, TEXPRO 2, allows getting a statistical-mathematical model.

The cotton yarn used in these experiments has the quality characteristics presented in Table 1:

Table 1. Cotton yarn characteristics

Characteristic	Unit of measure	Value
Linear density	dtex	600
Tenacity	cN/dtex	0,93
Elongation	%	6,1

Animal polymer is a protein derived from the simple hydrolysis of collagen, which is the principal protein constituent of animal hide, connective tissue and bones. Coated cotton yarn with natural animal polymer was produced in the laboratory by using the installation presented in Figure 1.

Natural animal polymer is considered to be hydrolysed collagen: $C_{102}H_{149}O_{38}N_{31}+H_2O = C_{102}H_{151}O_{39}N_{31}$ which gives an approximate chemical composition of 51.29% carbon, 6.39% hydrogen, 24.13% oxygen, and 18.19% nitrogen (6). Viscosity was measured by the flow velocity of the natural animal polymer solution through a funnel; the bloom measurement refers to the elasticity of a gelatinous mass, the higher the number, the greater the elasticity is. The characteristics of natural polymer are presented in Table 2.

The coated yarn was obtained from a solution whose components were mixed in a basin placed on a water thermostated bath at 65°C. Proportions of the components from the coating solution are presented in Table 3.

Table 2. Natural animal polymer characteristics

Chemical name	Hydrolysed collagen
Chemical Formula	$C_{102}H_{151}O_{39}N_{31}$
Viscosity (milipascal seconds)	140 – 160
Jelly Strength, Bloom Gram	300
pH	6,2
Water: (%)	12,6
Fat (%)	5,6
Ash (%)	1,2

Table 3. Proportion of solution components

Solution	Natural animal polymer (%)	Glycerine (%)	Starch (%)	Water (%)
1	20	7	2	71
2	23	7	2	68
3	30	7	2	61
4	37	7	2	56
5	40	7	2	51

After the solution was produced, it was placed on the other thermostated bath, heated with oil, placed on the laboratory installation which had the temperature set at 60°C to maintain the proper temperature. After the cotton yarn is immersed in the coating solution, it passes through a spinneret which has the role to give the proper diameter of the coated yarn. Coating material is placed on the yarn and then it enters a device which blows cold air; this operation is done because the coating material needs to settle and cool before winding. The conditions used to produce coated cotton yarn with natural polymer are presented in Table 4.

2.2. Installation for Producing Coated Polyester Yarn with Natural Animal Polymer

Coated yarn with natural animal polymer was produced by using the laboratory installation made for this purpose and presented in Figure 1.

The cotton yarn [2] is unwind from the coil and passed through the guidance rolls [1], the tensioning device [3], and with the help of the rolls [6] it is immersed in the thermostated bath [4]

which contain heated oil [5], where it is placed a basin with the natural animal polymer solution [7] used for coating. After the yarn is immersed, it is pulled through the spinneret [8] in the cooling zone [9] and through the guidance roll [10] to the winding mechanism [11].

2.3. Mathematical Model of the Breaking Force and Elongation of the Coated Cotton Yarn

The model, the simulation and the optimization of the treating processes shall follow a certain algorithm, which needs the following stages:

I – setting of an optimization criterion or the target function, Y_i , for the properties under study;

II – selecting the independent or decision-enabling variables, X_i ;

III – applying the mathematical model (find the target function) for the process under study regarding adhesion properties of the solution, as well as the same model simplification under reasonable limits;

IV – testing and interpreting the mathematical model, respectively the assessment of the extent to which it

represents the process under real conditions;

V – selecting the method to further determine the optimal solution or the optimum;

VI – finding the optimal solution and the maximum or minimum value of the target function or the mathematical model proposed.

2.3.1 Active Experimental Planning Central Compositionally Rotatable of 2² Order

The empirical model shape which lays at the basis of the central compositionally rotatable planning corresponds to the following relation:

$$Y = b_0 + \sum_{i=1}^n b_i x_i + \sum_{j=1}^n b_j x_i x_j \quad (1)$$

where Y is the response function; X_i, X_j – the coded variables of the process studied; b_0, b_i, b_j, b_{ij} – the model coefficients.

The significance of the coefficients was tested by using the t-Student test which, was followed by the finding and the interpretation of the target function optimum.

Table 4. Conditions used to produce cotton yarn coated with natural polymer

Type of yarn used for coating	Cotton Yarn
Temperature of the water thermostated bath (°C) used for mixing the solution components	65
Temperature of the oil thermostated bath (°C) from the laboratory installation	60
Winding speed (m/min)	5
Temperature of the airflow device (°C)	20
Diameter of the spinneret (mm)	0,7

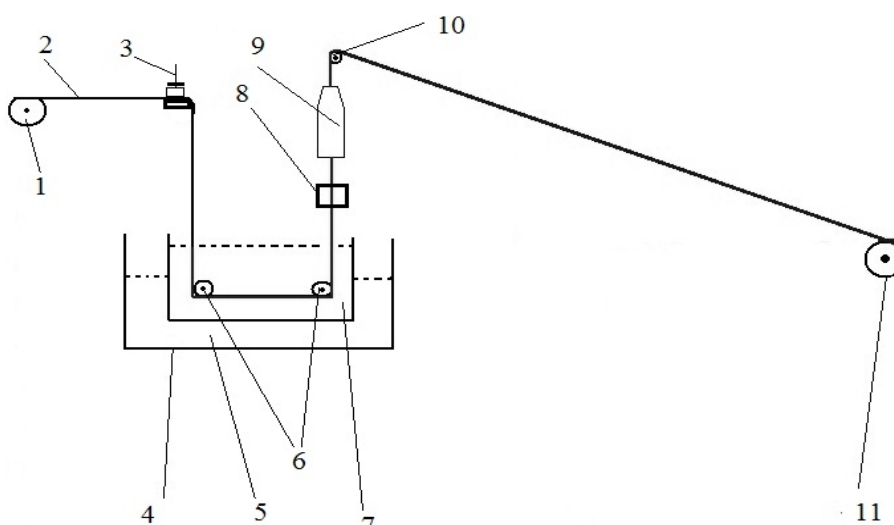

Figure 1. Schematic installation for produce coated yarns with natural animal polymer (1, 10: guidance rolls; 2: polyester yarn; 3: tension system; 4: thermostated bath; 5: heated oil; 6: rolls for immersing the yarn; 7: coating solution; 8: spinneret; 9: device with cold airflow; 11: winding mechanism)

The rotatable central composition program with independent variables was chosen because it is rotatable; the mathematical model obtained from processing statistical factorial experiment allows determining the response at equal distances from the center of the experiment with the same accuracy, regardless of the direction.

The statistically designed experiment usually involves varying two or more variables simultaneously and obtaining multiple measurements under the same experimental conditions [6]. To work out the present mathematical model, the experiment planning was performed in conformity with the rotatable central composition program of 2² order [10], considering two independent variables (X_i):

X₁ – concentration of the natural animal polymer from the solution;

X₂ – tension force.

The optimization criteria or the target function, taken as dependent variable (Y_i, N), were considered:

Y₁ – breaking force;

Y₂ – elongation;

According to the values of the dependent variables breaking force and elongation, the destination of the coated yarn will be established and the way the coated yarn will behave in the structure of a composite material during stresses will be known.

The concentration of natural animal polymer will influence the properties of the coated yarn by increasing the dependent variables. The tension force applied at the beginning of the installation is related to the cotton yarn, because the same cotton yarn was used for all the experiments. By increasing or decreasing the tension force applied on the yarn, it will be produced a modification of stretching,

which will affect the way the solution penetrates the cotton yarn and the way it will brace the fibres after cooling.

Experimental matrix contains 13 experiments, 8 of them being distinct, and 5 referring to the center program. The empirical mathematical model (functional relation) between the target function, Y_i (dependent variable) and independent variables (X₁, X₂) takes the form of a regression equation:

$$Y = b_0 + b_1X_1 + b_2X_2 + b_{11}X_1^2 + b_{22}X_2^2 + b_{12}X_1X_2 \quad (2)$$

2.3.2. Checking the Significance of Coefficients

Checking the significance of coefficients b_i Student test was realized by comparing the calculated statistics t_c to tabulated statistics t_{tab}.

Coefficients of the regression equation are considered significant for the significance level of α = 0.05 and v = n - 1 degrees of freedom. If the relation is satisfied:

$$t_c \geq t_{tab(\alpha, v)} \quad (3)$$

To determine t_c statistics it was used the following relation:

$$t_c = \frac{|b_i|}{S_{b_i}} \quad (4)$$

where b_i is the regression coefficient tested; S_{bi} the standard deviation.

2.3.3. Checking the Adequacy of the Mathematical Model

Appropriateness of the mathematical model proposed was checked by computing the Fisher test value, F:

$$F_c = \frac{\sum_{i=1}^n (Y_{ei} - \bar{Y}_e)^2}{\sum_{i=1}^n (Y_{eki} - Y_{ek})^2} \quad (5)$$

where Y_{ei} – is the experimental values of the dependent variable; \bar{Y}_e is the

average value of the dependent variable; Y_{eki} is the experimental values of the dependent variable in the center of the program and \bar{Y}_{ek} is the average value of the experimental values in the center of the program.

The mathematical model is considered appropriate if the condition expressed by inequality is acquired:

$$F_c \geq F_{tab}(\alpha, v_1, v_2) \quad (6)$$

where F_c represents the calculated value of F statistic; F_{tab}(α, v₁, v₂) the tabulated value with distribution F, with v₁=v₂=N-1 degrees of freedom for default significance level α.

Another way to check the adequacy of the model, which means the ability of the model to properly represent the studied process, is to determine the percentage deviations between measured and calculated values:

$$Deviation = \left| \frac{Y_m - Y_c}{Y_m} \right| \cdot 100 \quad (7)$$

If the percentage differences are less than 10%, then the mathematical model is appropriate [7].

3. RESULTS AND DISCUSSIONS

The code and the real values of the two independent variables X₁ – concentration of natural animal polymer and X₂ – tension force applied to the cotton yarn during production process is presented in Table 5.

On the base of the mathematical modeling program, the dependent variables, Y₁ – breaking force and Y₂ – elongation at break were measured. The calculated values and deviations are presented in Table 6.

Table 5. Code and real values for the two independent variables X₁ and X₂

No. of the experiment	X ₁		X ₂	
	Real (%)	Code	Real (cN/tex)	Code
1	30	+1	0,8	+1
2	23	-1	0,8	+1
3	37	+1	0,2	-1
4	23	-1	0,2	-1
5	20	-1,414	0,5	0
6	40	+1,414	0,5	0
7	30	0	0,1	-1,414
8	30	0	0,9	+1,414
9	30	0	0,5	0
10	30	0	0,5	0
11	30	0	0,5	0
12	30	0	0,5	0
13	30	0	0,5	0

Table 6. Experimental matrix

Exp. Nr.	Y ₁ Measured (N)	Y ₁ Calculated (N)	Deviation (%)	Y ₂ measured (%)	Y ₂ calculated (%)	Deviation (%)
1	6,01	6,204	3,22	6,09	6,268	2,922
2	7,2	7,448	3,44	7,52	7,805	3,789
3	5,09	5,140	0,98	5,12	5,195	1,464
4	6,38	6,414	0,53	6,97	7,132	2,324
5	5,85	5,729	2,06	6,79	6,874	1,237
6	9,68	9,22	4,75	9,95	9,613	3,386
7	8,8	8,934	1,52	9,54	9,404	1,425
8	7,87	7,854	0,2	8,43	8,312	1,399
9	8,11	8,278	2,07	9,62	9,546	0,768
10	8,53	8,278	2,95	9,91	9,546	3,762
11	8,05	8,278	2,83	9,25	9,546	3,201
12	8,69	8,278	4,74	9,81	9,546	2,690
13	8	8,278	3,47	9,13	9,546	4,557

The regression equations for the dependent variable Y₁ – breaking force and Y₂ – elongation, using the TexPro2 program, are as follows:

$$Y_1 = 8,278 + 0,987 * X_1 - 0,382 * X_2 - 0,727 * X_1^2 - 0,442 * X_2^2 \quad (8)$$

$$Y_2 = 9,546 + 0,969 * X_1 - 0,386 * X_2 - 1,152 * X_1^2 - 0,844 * X_2^2 \quad (9)$$

The significance of the regression equation coefficients of Y₁ (breaking force) from processing experimental data was determined by using Student test ($t_{tab(\alpha=0,95;v=4)} = 2,132$) for the two independent variables (X₁ – concentration of natural animal polymer from the coating solution), (X₂ – tension force). They are shown in Table 7:

Table 7. Regression equation coefficients and their significance for Y₁

Coefficient	Value	Statistic t _c	Coefficient significance
b0	8.278	59,225	significant
b1	0.987	8,932	significant
b2	-0.382	-3,456	significant
b11	-0.727	-6,134	significant
b22	-0.442	-3,730	significant

From the analysis of Table 7 it can be seen that for breaking force of coated cotton yarn with solution containing natural animal polymer, the coefficients are significant because it was found as $t_c \geq t_{tab(\alpha=0,05;v=4)}$.

The significance of the regression equation coefficients of dependent variable Y₂ (elongation) from processing experimental data was determined by using Student test ($t_{tab(\alpha=0,95;v=4)} = 2,132$) for the two independent variables (X₁ – concentration of natural animal polymer from the coating solution), (X₂ – tension force). They are shown in Table 8:

Table 8. Regression equation coefficients and their significance

Coefficient	Value	Statistic t _c	Coefficient significance
b0	9,546	62,83	significant
b1	0,969	8,006	significant
b2	-0,386	-3,912	significant
b11	-1,152	-8,877	significant
b22	-0,844	-6,504	significant

From the analysis of Table 8 it can be seen that for coated cotton yarn with solution containing natural animal polymer, the coefficients are significant because it was found as $t_c \geq t_{tab(\alpha=0,05;v=4)}$.

The adequacy of the mathematical model is highlighted by the Fisher test, for dependent variable Y₁, $F_c = 57,05 > F_{tab(0,05,12,12)} = 2,67$,

and by the percentage of deviations between measured and calculated values (Table 6), which are below 5% for the samples bonded with a layer of adhesive solution. The mathematical model for the dependent variable breaking force is thus adequate.

For the dependent variable Y₂ – elongation, the Fisher test is $F_c = 69,23 > F_{tab(0,05,12,12)} = 2,67$ and the deviation percentage is below 5%.

This indicates that the mathematical model for the dependent variable elongation is adequate.

The analysis of the regression equations (8, 9) of the dependent variables – breaking force and elongation highlights the following:

- the independent parameters X₁ – concentration of natural polymer and X₂ – tension force influence differently the breaking force and

the elongation. The coefficient b_1 is greater than 2.6 times than the coefficient b_2 . This indicates a stronger influence of concentration of natural animal polymer – X_1 on the breaking force and the elongation compared to the parameter X_2 – tension force.

- the regression coefficients of main effects (b_1 and b_2) have different signs – ($+b_1$) and ($-b_2$) –, which leads to the idea that the objective function will be maximized through the variation of experimental parameter X_1 to positive levels and of experimental parameter X_2 to negative levels of the objective function.
- The analysis of the quadratic terms coefficients (b_{11} and b_{22}) shows that the rate of change of the dependent variable Y_1 and Y_2 , depending on the parameters X_1 and X_2 , is greater when it depends on the parameter X_1 (8,7%) then when it depends on the parameter X_2

(5,33%) for Y_1 and X_1 (12%) and X_2 (8,8%) for Y_2 .

- quadratic form (b_{11} and b_{22}) has the same sign (negative) and will decrease the value of dependent variable – breaking force and elongation.
- the presence of the second-degree terms in the regression equation indicates a well-formed response surface.
- in conclusion, the analysis of the regression equation coefficients emphasizes the influence of independent parameters on the value of depended variable characteristic.

In the case of coated cotton yarn, there is a strong statistical connection between the dependent variables (breaking force, elongation) and independent variables (concentration and tension force), as indicated by the value of multiple correlation coefficient of breaking force $R_{Y \cdot X_1, X_2} = 0,982$,

and $R_{Y \cdot X_1, X_2} = 0,954$ for elongation at break.

Coefficient of multiple determination ($R^2 = 0,910$) indicates an influence of 91% of independent parameters on elongation; the remaining 9% represents the influence of the other factors that weren't taken into question.

For breaking force, Coefficient of multiple determination ($R^2 = 0,964$) indicates an influence of 96.4% of independent parameters; the remaining 3,6% represents the influence of the other factors that weren't taken into question.

Response surface resulting from the graphics processing of the mathematical model obtained for dependent variable Y_1 – breaking force and Y_2 – elongation represents an elliptic parabola whose projection in X_1OX_2 plan stands for a family of ellipses, Figure 2 and 3.

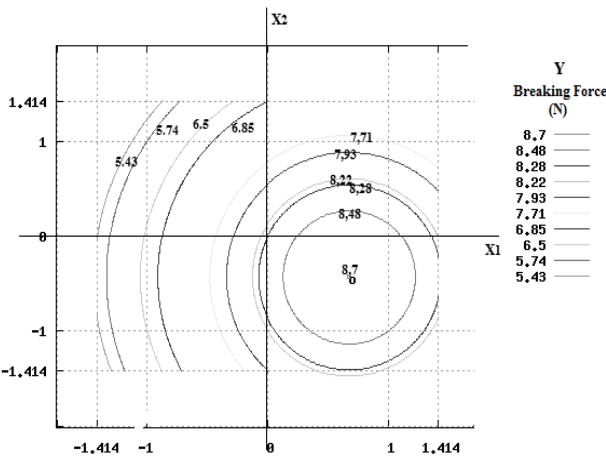

Figure 2. 2D graphical representation of the level curves $Y = \text{constant}$ for response surface $Y_1 = f(X_1, X_2)$

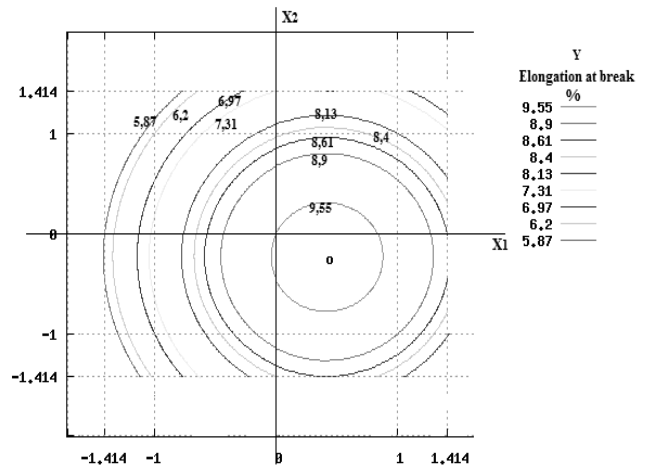

Figure 3. 2D graphical representation of the level curves $Y = \text{constant}$ for response surface $Y_2 = f(X_1, X_2)$

The projection in X_1OX_2 plan of parabolic peak represents the extreme, which is the point of maximum $Y_1=8,695$ N for breaking force, corresponding to the following coordinates: $X_1=0,679$ and $X_2=-0,432$, which are code values and correspond to the following real values: $X_1=34,5$ % and $X_2=0,37$ cN/tex. For elongation at break, a point of maximum $Y_2 = 9,794\%$ is obtained for the coordinates $X_1 = 0,420$ and $X_2 = - 0,229$; the maximum elongation at break for the

coated cotton yarn is obtained for a concentration of natural polymer animal of 33% and a tension force of 0,43 cN/tex.

Maximum points corresponding to breaking force and elongation at break show an increase for coated cotton yarn in comparison with the carrier cotton yarn, which has the breaking force of 5,6N and the elongation at break of 6,1%. This increase results from the fact that the solution based on

a natural animal polymer is an aqueous solution; it penetrates the cotton yarn, bracing the cotton fibers after cooling. This brace of fibers improves the coated yarn tensile properties. The coating material based on a natural animal polymer has a positive effect on the breaking force, improving this important characteristic.

Given the position of the maximum, resulted from the graphics processing of mathematical model obtained for the

breaking force and the elongation at break of coated cotton yarn with solution based on natural animal polymer, it is expected that changes in the parameters X_1 and X_2 in quadrant II should be used to maximize the objective functions Y_1 and Y_2 .

4. CONCLUSIONS

The rotatable central composition design enabled by factorial program order 2^2 has led to the following general conclusions:

- The variation mode of the independent variables chosen for breaking force and elongation: X_1 – concentration of natural animal polymer from the coating solution; X_2 – tension force corresponds to the values set by the application of the active empirical experimental planning possible through the rotatable central composition design of the 2^2 order, used by the program TexPro2;

- Mathematical equations were found for both suggested target functions: Y_1 – breaking force; Y_2 – elongation at break; the mathematical models were validated by the application of the t test (Student) and by models suitability check with Fisher test; the expressions of the mathematical models are appropriate, corresponding to the experimental data; thus, the optimum values were found for the target functions, which are maximum points.

- If 2 independent variables vary (concentration of natural animal polymer from solution and tension force), by the interpretation of the mathematical models found for the 2 target functions, the following conclusions result:
 - Maximum of breaking force is obtained for a concentration of natural polymer animal of 34,5% and a tension force of 0,37 cN/tex.
 - Maximum of elongation at break is obtained for a concentration of

natural polymer animal of 33% and a tension force of 0,43 cN/tex.

Natural animal polymer improves the characteristics of the yarn, which means that the natural animal polymer and the cotton yarn act as a whole. Being an aqueous solution, it goes through the fibers of the cotton yarn and after cooling gathers the fibers and improves the breaking force and the elongation at break.

There is an increase of 35% in breaking force of coated cotton yarn and of 37% in elongation compared to the simple cotton yarn.

Taking into consideration the producing temperature for natural polymer, different agents (electromagnetic, anti-microbial) can be added in the coating solution, which can improve the final product characteristics.

REFERENCES

1. Akesson D., Skrifvars M., Walkenstrom P., 2009, "Preparation of Thermoset Composites from Natural Fibers and Acrylate Modified Soybean Oil Resins", *Journal of Applied Polymer Science*, Vol:114, pp:2502-2508.
2. Hailin L., Gunasekaran S., 2010, "Cow blood adhesive: Characterization of physicochemical and adhesion properties", *International Journal of Adhesion & Adhesives*, Vol:30, pp:139–144.
3. Keyur P.S., Sujata S.K., Natvar K.P., Animesh K.R., 2003, "Castor oil based polyurethane adhesives for wood-to-wood bonding", *International Journal of Adhesion & Adhesives*, Vol:23, pp:269–275.
4. Brockmann W., Kligen J., Schroder B., 2008, "Adhesive Bonding-Materials", Applications and Technology, Wiley-VCH, ISBN: 978-3-527-31898-8.
5. Packham D.E., 2005, "Handbook of Adhesion, Second Edition", John Wiley & Sons, ISBN: 0-471-80874-1.
6. İlbay I.İ., Çelik N., 2009, "A Statistical and Experimental Investigation on Product Design for Copolymer Based Multichannel Polyester Draw Textured Yarns", *Tekstil ve Konfeksiyon*, Vol:19(4), pp:291-298.
7. Ciocoiu M., 2002, *Bazele statistico-matematice ale analizei și controlul calității în industria textilă*, Ed. Performantica, Iași.