

## Zooming Procedure for the Thermo-economic Diagnosis of Highly Complex Energy Systems

Vittorio VERDA\*

Department of Energy Engineering - Polytechnic of Turin. Turin-Italy.

Tel: (+39) 011 564 44 68, Fax: (+39) 011 564 44 99

E-mail: verda@polito.it

Luis SERRA and Antonio VALERO

CIRCE - Department of Mechanical Engineering University of Zaragoza.

Zaragoza-Spain.

Tel: (+34) 976 76 18 63, Fax: (+34) 976 73 20 78

E-mail: serra@posta.unizar.es

### Abstract

Diagnosis techniques are usually adopted in energy systems to prevent anomalies that can cause, if not repaired, failures (Zaleta 1997). The aim of thermo-economic diagnosis is different in that it is oriented to plant energy savings while the plant is in operation. In particular, it focuses on discovering reductions in system efficiency (detection of anomalies), locating where these inefficiencies have occurred, and understanding their causes. The solution of this problem is not banal, due to 'collateral effects'. In fact, when the efficiency of a component decreases because of an anomaly, the efficiencies of the other components generally vary. Moreover, if some settings are not complied with, the control system intervenes and commands an adjustment, which changes the effects of the anomaly on the components.

This paper proposes an approach particularly helpful for the diagnosis of complex energy systems. With this approach, the system is first divided into macro-components. A zooming strategy allows one to focus attention on a small part of the system. Then a detailed analysis of a few macro-components (the really malfunctioning ones) is conducted. Such an analysis is based on the principle of eliminating the contributions of the main collateral effects, i.e. the efficiencies of the components dependent on their operating conditions and control system interventions.

In this paper, the procedure is presented and applied to a combined cycle, composed of two gas turbines, two HRSGs and a steam turbine.

*Key words: thermo-economic diagnosis, malfunction location, induced effects, control system effects*

### 1. Introduction

The engineering discipline called *diagnosis* deals with the analysis of the operating conditions of energy systems in order to discover possible anomalies. In particular, the thermo-economic approach to diagnosis addresses those anomalies provoking variations in plant efficiency. Its aim consists of detecting possible malfunctions, localizing them, quantifying their effects on the components and understanding the

causes. These tasks characterize the *inverse problem* of diagnosis, which consists of finding the causes of variations in efficiencies by measuring their effects. In contrast, the *direct problem* consists of determining the effects of known anomalies.

Thermoeconomics considers the productive processes occurring in a system. The physical model is represented by a *productive structure*, which expresses the productive role of each

---

\* Author to whom all correspondence should be addressed.

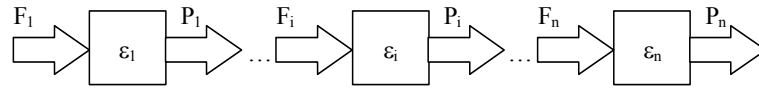

Figure 1a. Sequential process (reference condition)

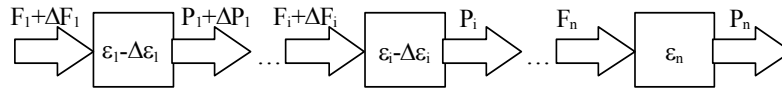

Figure 1b. Effect of an anomaly (operating condition)

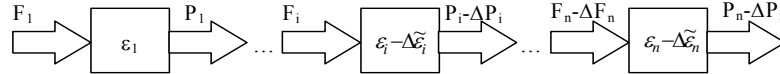

Figure 1c. Elimination of the control system effects (free condition)

component by defining the required resources and the provided product. Exergy is usually used to define resources and products (Valero et al., 1986). Sometimes it is split into thermal and mechanical components (Tsatsaronis et al., 1990) or complemented by negentropy flows (Frangopoulos 1987; von Spakovsky and Evans 1990).

A general diagnosis procedure is conducted by calculating some thermoeconomic quantities, which highlight the behavior of each subsystem and comparing the values found at two operating conditions: an actual condition and a reference condition, where the system works without anomalies. The advantage of such a procedure is a systemic and unique approach to plant analysis, whatever the cause of the malfunction. This procedure can furthermore easily be adapted to a computer-aided program for plant diagnosis.

The diagnosis problem is generally not easy to solve, due to the interconnections between the components and the dependence of their efficiencies on the operating conditions. To better explain this problem and to formulate a possible solution, let us consider the sequential productive structure shown in Figure 1 (Lozano and Valero 1993).

In a sequential process, the product (P) of a component completely feeds the downstream component, being its only fuel (F). If an anomaly occurs in the  $i^{\text{th}}$  component (Figure 1b), its efficiency decreases and a larger amount of fuel ( $F_i + \Delta F_i$ ) is required to maintain the same product  $P_i$  as at the reference condition (Figure 1a). All the upstream components must increase their production since the malfunctioning component requires larger resources. This effect is called dysfunction (Torres et al., 1999). A dysfunction is not necessarily a negative effect in and of itself. It only means that the production of a component is different than that expected. However, a dysfunction can generate negative effects. In fact, variation of the operating condition of a component generally causes its

efficiency to vary, even though no anomaly has occurred inside the component. This type of behavior is called an induced malfunction, i.e. it is induced by the presence of anomalies in other components (Valero et al. 1999). A decrease in efficiency can also be caused by an anomaly occurring in the component itself.

Assuming  $\Delta \tilde{\epsilon}_i$  to be the reduced efficiency in the  $i^{\text{th}}$  component caused by the anomaly, component production decreases by an amount  $\Delta P_i$  (see Figure 2) at constant fuel usage. Overall plant production decreases too. Under this condition, the control system intervenes in order to restore the previous production. The plant moves toward the new reliable operating condition shown in Figure 1b and characterized by the same production as at the reference condition. Since the  $i^{\text{th}}$  component produces the amount  $P_i$  (as at the reference condition), the downstream components are not affected by the presence of the anomaly and their efficiencies assume the expected values. In contrast, upstream components increase their production (dysfunction) because of the larger amount of fuel required by the  $i^{\text{th}}$  component.

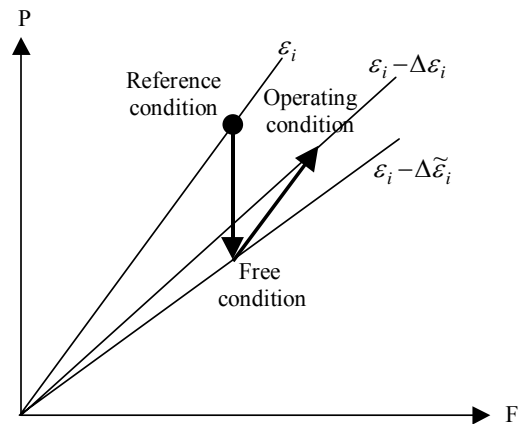

Figure 2. Efficiency curves of the  $i^{\text{th}}$  component at different operating conditions

These dysfunctions generally cause the efficiencies of components to vary. For this reason, the anomaly cannot be found by means of a simple calculation of efficiencies. Furthermore, at the new operating condition resulting from intervention of the control system, overall plant fuel use increases. The additional consumption  $\Delta F_1$  is called the *fuel impact* (Reini 1994).

In a sequential process, the correct localization of anomalies can be obtained by filtering the intervention of the control system. The determination of the condition that would occur if the control system did not intervene, the *free condition* (Verda et al., 2001a), allows one to achieve this goal. For the sequential process, this condition is characterized by the same fuel as at the reference condition, but a different product, as shown in *Figure 1c*. The anomaly can be correctly located in the  $i^{th}$  component by comparing the free and reference conditions: the uppermost component exhibiting a reduced efficiency is characterized by an intrinsic malfunctioning behavior. For simplicity, if several anomalies have occurred, they can be found by iteratively applying the localization procedure and removing them. In reality, it is possible to locate different anomalies at the same time by means of a procedure, which allows one to filter all the induced effects (Verda et al., 2001b).

In a highly complex energy system, the localization of anomalies should be preceded by the construction of a less detailed sequential productive structure, obtained by grouping together several components into macro-components. As an example, a combined cycle

plant can be represented as shown in *Figure 3*. In this way, it is possible to locate the first anomaly in the uppermost macro-component, i.e. the nearest to the plant fuel, characterized by a varied (reduced) efficiency. A comparison between free and reference conditions is, thus, successful.

The precise location of the anomaly in a restricted volume is done by applying a procedure to the macro-component that allows one to eliminate the induced effects. Localization of multiple anomalies requires the application of the procedure presented here to all of the macro-components of the system downstream of the uppermost macro-component.

As previously specified, induced effects take place when a component without anomalies works at a non-reference condition. From a thermoeconomic point of view, this means that the component's fuel value differs from the reference value. These effects ideally are eliminated by means of a thermoeconomic model of the components without anomalies, provided that each component is isolated and its reference resources artificially restored. If, at this point, there is a production different from the reference value, an intrinsic malfunction is present.

This diagnosis approach entails a progressive elimination of *disturbances*, which impede one from clearly seeing the cause of the degraded behavior of the system. The procedure only requires knowledge of several operating conditions: the condition to be examined, the reference condition, and some other conditions to be used for evaluating control system effects.

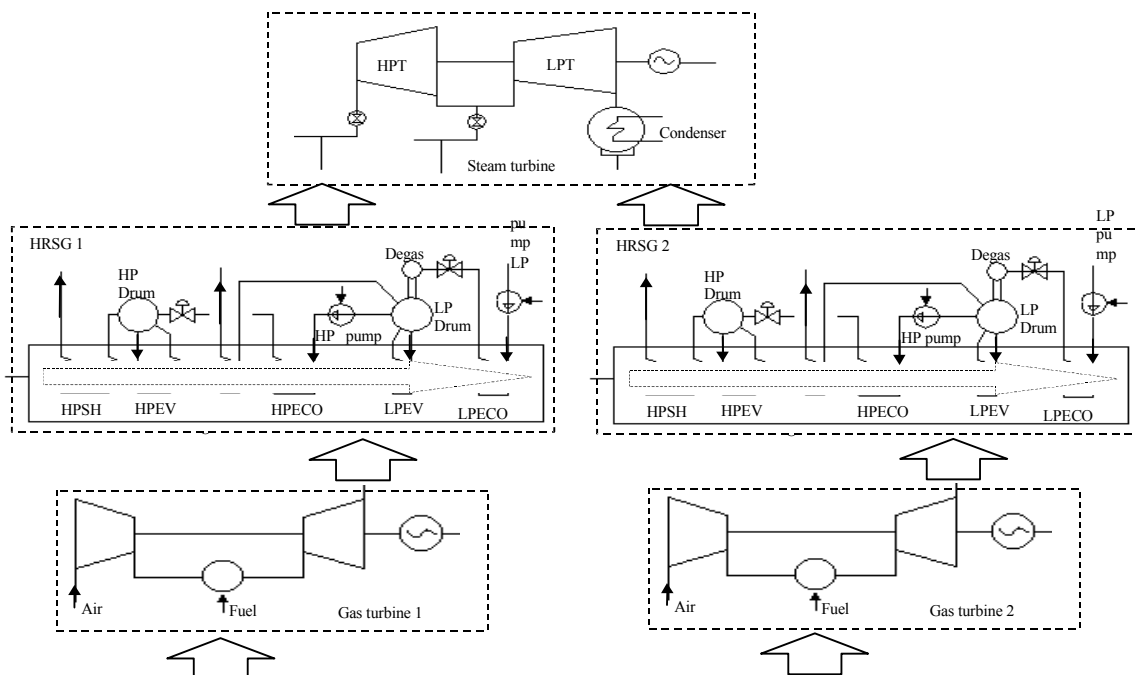

Figure 3. Sequential scheme of a combined cycle

For the application presented in this paper, a simulator has been used, instead of the plant itself, in order to reproduce the operating conditions corresponding to different anomalies. Once the effects of the anomalies have been determined, the analysis is conducted by assuming that the real location of the anomalies is unknown. Thus, only deviations in thermoeconomic quantities and the positions of the control settings are used to diagnose the anomaly.

Finally, the contribution of the intrinsic and all the induced effects, eliminated at each step of the diagnosis procedure, is shown in this paper for some of the anomalies.

## 2. The Thermoeconomic Model

The Structural Theory (Valero et al., 1992) is adopted for building the thermoeconomic model of the system. In this approach each subsystem or component is identified by a single product (without losing generality) but different fuels, provided by as many components. This product feeds other components or constitutes a part of the plant product. In Figure 4, an example of a productive structure is shown. Flow  $E_{ij}$  is fuel for the  $j^{\text{th}}$  component and the product of the  $i^{\text{th}}$  component. Plant fuels and products are indicated, respectively, as  $E_{0i}$  and  $E_{i0}$ .

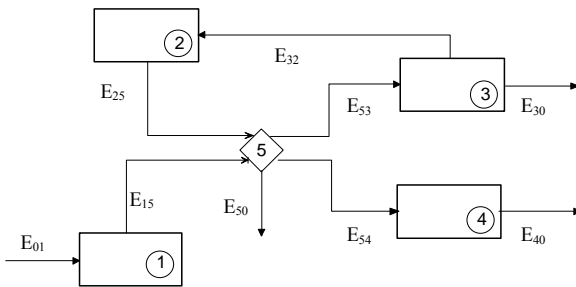

Figure 4. Example of a productive structure

The thermoeconomic behavior of components is expressed and evaluated by the unit exergy consumption. It is defined as the ratio between each resource of the  $i^{\text{th}}$  component and its product:

$$k_{ji} = \frac{E_{ji}}{P_j} \quad (1)$$

The first step for whatever diagnosis procedure is detection of the anomalies. The presence of an anomaly can be discovered by means of a comparison of the fuel consumptions calculated at the operating and reference conditions. A different consumption can be

caused by a different plant production or the presence of an anomaly. The Structural Theory takes into account these two contributions in a general formulation of fuel consumption called the fuel impact formula (Torres et al. 1999; Reini 1994; Valero et al. 2002), which is particularly helpful for multi-product systems:

$$\Delta F_T = \sum_{i=1}^n k_{p_i}^* \cdot \Delta P_{e_i} + \sum_{i=1}^n \left( \sum_{j=0}^n k_{p_j}^* \cdot \Delta k_{ji} \right) P_{i_{ref}} \quad (2)$$

where:

$\Delta F_T$  is the fuel impact;

$k_{p_j}^*$  is the unit exergy cost of the product of the  $j^{\text{th}}$  component, calculated at the operating condition. The cost of a flow indicates the amount of overall fuel required to produce it. The unit exergy cost is obtained as a ratio between the cost of the flow and its exergy;

$\Delta P_{e_i}$  is the variation in overall plant production provided by the  $i^{\text{th}}$  component, which occurs between operating and reference conditions;

$\Delta k_{ji}$  is the variation in unit exergy consumption  $k_{ji}$ , which occurs between operating and reference conditions.

$P_{i_{ref}}$  is the total product of the  $i^{\text{th}}$  component at the reference condition.

The first term on the right hand side is associated with a different plant production, while the second with a change in behavior of the components. This is the term to be considered for diagnosis purposes: it is not zero if an anomaly has occurred in the system. Moreover, each element of the summation expresses the effect of the anomalies on a component, allowing for their quantification.

## 3. Location of Anomalies at the Macro-Component Level

The localization of anomalies can be accomplished by first identifying the macro-component where they are located. This second step of diagnosis can be achieved by eliminating the malfunctions that are propagated upstream, as happens in a sequential structure. Thus, the uppermost macro-component characterized by malfunction is also the subsystem where the anomaly is located. For example, if a malfunction occurs in the HRSG1 (see Figure 3) and the effects induced toward the uppermost macro-component (i.e. the TG1 gas turbine) are eliminated, no malfunctions occur in the TG1. The HRSG is identified as the macro-component

containing the anomaly because it is the uppermost component, which is characterized by a degraded efficiency.

The flows of the productive structure depicted in *Figure 3* only go downstream. The only malfunctions propagating upstream are those provoked by the control system operation. If an anomaly occurs, for example, in the steam turbine, its efficiency decreases and its production too. If the total production is fixed, the gas turbines are adjusted in order to increase their production and restore their set point. The gas turbine adjustments generally make their efficiencies vary, which means that they suffer induced malfunctions. The effects of the anomaly occurring in the steam turbine have, thus, been propagated upstream and, as a consequence, the gas turbines have changed their operating condition.

The use of a diagnosis procedure, which filters the effects of the control system, allows one to eliminate the effects directed upstream. A possible approach consists of determining the free condition (Verda et al. 2001a; Verda 2001), i.e. the artificial operating condition that would occur in a malfunctioning plant if its control system did not operate. This condition can only be determined mathematically, since in reality it is not acceptable. Its determination can be achieved by considering the operating condition and by restoring the same adjustment set (control settings) as at the reference condition. The free condition is, thus, characterized by the same anomaly as at the operating condition, but the effects of the control system do not appear. The general productive flow at the free condition  $E_{free}$  is:

$$E_{free} = E_{op} + \sum_{i=1}^{nap} \frac{dE}{dx_i} \cdot (x_{i_{ref}} - x_{i_{op}}) \quad (3)$$

where  $E_{op}$  is the productive flow at the operating condition,  $nap$  is the number of adjustment parameters,  $x$ , moved by the control system in order to determine an acceptable operating condition. If the combined cycle in *Figure 3* is considered, the adjustment parameters are the igv (inlet guide vane) position and the fuel mass flow rate. Therefore, equation (3) can be written as:

$$E_{free} = E_{op} + \frac{dE}{dx_1} (x_{1_{ref}} - x_{1_{op}}) + \frac{dE}{dx_2} (x_{2_{ref}} - x_{2_{op}}) \quad (4)$$

The derivatives can be evaluated by means of additional available data. These are productive flows  $E_{add}$  determined at as many conditions as possible, all of which are different since they correspond to different plant production or ambient conditions but for none of which any anomalies have occurred. Thus,

$$\begin{pmatrix} \frac{dE}{dx_1} \\ \frac{dE}{dx_2} \end{pmatrix} = \begin{bmatrix} x_{1_{add1}} - x_{1_{ref}} & x_{2_{add1}} - x_{2_{ref}} \\ x_{1_{add2}} - x_{1_{ref}} & x_{2_{add2}} - x_{2_{ref}} \end{bmatrix}^{-1} \cdot \begin{Bmatrix} E_{add1} - E_{ref} \\ E_{add2} - E_{ref} \end{Bmatrix} \quad (5)$$

where the  $x_{add}$ s are the adjustment parameters at these conditions.

The comparison between the free and reference conditions can be made by means of the values assumed by each unit exergy consumption ( $\Delta k_{ij}$ ). An increased value means that the component needs more fuel to supply the same product as at the reference condition, which also means that this process is less efficient. By means of such a comparison, only the intrinsic malfunction (associated with the anomaly) and the malfunctions induced by the dependencies of the performance of the components at the operating condition are still present.

Four different cases, each corresponding to a different anomaly simulated in the system, are considered here. The four anomalies are:

- MF1: an efficiency reduction (1%) in the compressor efficiency curves in order to simulate fouling (Sedigh, Saravanamutoo 1991);
- MF2: an efficiency reduction (-1%) in the gas turbine in order to simulate a general performance deterioration such as surface erosion or fouling of the annulus and airfoils (Diakunchack 1992);
- MF3: a heat transfer coefficient reduction (-5%) of the high pressure evaporator to simulate its fouling;
- MF4: an efficiency reduction (-1%) of the high-pressure steam turbine to simulate a performance deterioration.

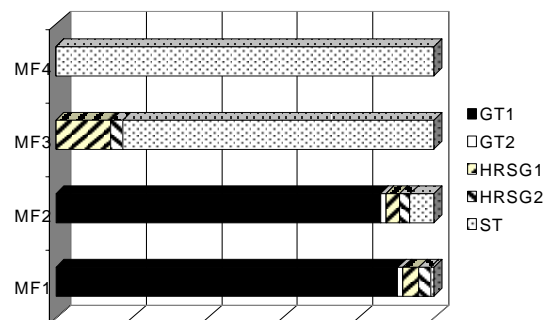

*Figure 5. Localization of anomalies in macro-components*

All of these anomalies have the same order of magnitude, i.e. they determine comparable additional fuel consumptions.

The graph in *Figure 5* shows variations in unit exergy consumptions calculated for the macro-components as the difference between the values at the free and reference conditions. The uppermost components (the row bars closest to the left side of the graph) where variations in the unit exergy consumption are found are the malfunctioning ones.

#### 4. Localization of the Anomalies in Components

The third step of the analysis aims at eliminating the last induced effect, i.e. variations in components efficiencies due to different inlet conditions. As explained before, when the fuel of a component varies, its production varies, too. Generally their ratio (i.e. the unit exergy consumption) does not remain constant. Thus, malfunctions also take place in some components if no anomaly has occurred.

This analysis is only made for the macro-component identified as the one containing the anomaly in the previous step. Single anomalies have been considered here, but when a diagnosis procedure is applied in a real plant, the number of anomalies is a priori unknown. Thus, induced effects should be eliminated from the whole system in order to identify all the intrinsic effects. This can be done by applying the procedure proposed here as many times as the number of anomalies that have occurred.

The induced effects are ideally eliminated when each component, at the free condition, is isolated and the reference inlet conditions are then restored. In a thermoeconomic representation, this means that the same fuel as at the reference condition is imposed. Thus, a component production different from the expected value is symptomatic of an intrinsic malfunction. This step can only be made mathematically. A thermoeconomic model, which allows one to calculate the product of a component when its fuel varies, is required to achieve this goal.

Here, an approach developed from previous work (Verda et al., 2001b) is proposed. A simple thermoeconomic model allows one to evaluate the effect of fuel changes on the unit exergy consumptions of components, i.e.:

$$\hat{k}_{ji} = k_{ji,ref} + \sum_{l=0}^n \left( \frac{\partial k_{ji}}{\partial E_{jl}} \cdot \Delta E_{jl} \right) \quad (6)$$

This equation is a thermoeconomic model of a component working without anomalies. In fact, all the operating conditions are obtained from the reference condition by only varying the fuels and moving toward the free condition ( $\Delta s$ , thus, the variation of fuel between the reference and free conditions as shown in a succeeding

paper (Verda et al., 2002) where the case MF3 is analyzed in depth).

Derivatives are calculated, as shown in the previous paragraph, by means of available data corresponding to the plant operating without anomalies and with different boundary conditions. These derivatives are zero if a variation of flow  $E_{jl}$  does not affect the unit exergy consumption  $k_{ji}$ . Equation (6) is a first order development of the function expressing the thermoeconomic behavior of a component. It means that its use is recommended for slight deviations in fuels with respect to the reference fuels. Otherwise, important non-linearities can take place.

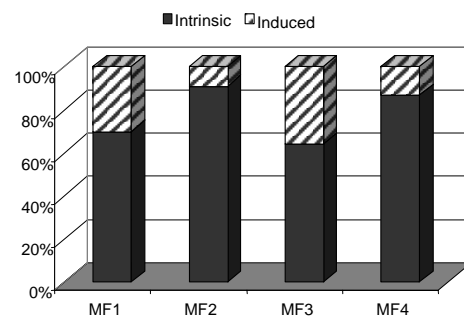

Figure 6. Localization of anomalies in components

In *Figure 6*, the results obtained by applying the diagnosis procedure are shown. Plain areas are the intrinsic malfunctions found, while striped areas are the residual induced malfunctions. These are non-linearities, which occurred because the hypothesis of slight anomalies was not satisfied. In all cases, the intrinsic malfunction is significantly greater than the induced effects so that the anomalies can be correctly located.

#### 5. Quantification of the Effects of the Anomalies

The variation in unit exergy consumption is a suitable parameter for achieving the main purpose of diagnosis, i.e. the localization of anomalies. Nevertheless, it does not provide any quantification of effects on the overall plant (Stoppato and Lazzaretto 1996). To do so, the fuel impact associated with malfunctions, introduced above, can be successfully adopted. This parameter is also called the cost of malfunctions,  $MF^*$  (Torres et al., 1999). Using this parameter, equation (2) can be written as:

$$\Delta F_T = \sum_{i=1}^n MF_i^* + \sum_{i=1}^n k_{p_i}^* \cdot \Delta P_{e_i} \quad (7)$$

The productive flows at the operating, reference and free conditions allow one to

calculate the variation in unit exergy consumption, the malfunctions and their cost. The values of the latter are calculated using:

$$\Delta F_{ji} = k_{p_j}^* \cdot (k_{ji_{op}} - k_{ji_{ref}}) P_{i_{ref}} \quad (8)$$

Each element  $\Delta F_{ji}$  represents the fuel impact caused by the variation in unit exergy consumption in the  $i^{\text{th}}$  component. The sum of the  $i^{\text{th}}$  terms is then the total impact of malfunctions on the  $i^{\text{th}}$  component, while the sum of all the elements  $\Delta F_{ji}$  is the total cost of the malfunctions.

The elements in TABLE 1A are the cost of malfunctions calculated for each component for case MF1. These elements are calculated as the difference between operating and reference conditions. Thus, the contributions of the control system are still present.

In TABLE 1B, the contribution of the control system has been eliminated by substituting the operating condition with the free condition in equation (5). The unit cost of the product of the  $j^{\text{th}}$  component is calculated at the free condition too.

TABLE 1A. COST OF THE MALFUNCTIONS WHEN THE CONTROL SYSTEM IS IN OPERATION [KW].

	GT1	GT2	HRSG1	HRSG2	ST
Ambient	715	-9	15	15	0
GT1	0	0	-56	0	0
GT2	0	0	0	-47	0
HRSG1	0	0	0	0	1048
HRSG2	0	0	0	0	-960
ST	0	0	0	0	0
Total cost of malfunctions					722 kW

TABLE 1B. COST OF THE MALFUNCTIONS WITHOUT CONTROL SYSTEM OPERATION [KW]

	GT1	GT2	HRSG1	HRSG2	ST
Ambient	585	-9	12	12	0
GT1	0	0	-34	0	0
GT2	0	0	0	-32	0
HRSG1	0	0	0	0	668
HRSG2	0	0	0	0	-662
ST	0	0	0	0	0
Total cost of malfunctions					540 kW

The total fuel impact associated with the control system is the difference between the total cost of the malfunctions calculated in tables 1a and 1b (722-540 kW). It corresponds to the variation in cost of the malfunctions between the operating and free conditions, i.e. the conditions after and before, respectively, the control system

has commenced operation, supposing, of course, that the anomaly appears instantaneously.

In order to better characterize the effect of the control system operation on the system, the total impact is now split among the macro-components. These contributions are obtained as the difference between the total impact of malfunctions on the macro-component, calculated with and without the contribution of the control system. As an example, for case MF1, the impact of the control system on the GT1 gas turbine is the difference between the sum of the first column in table 1a (715 kW) and the sum of the first column in table 1b (585 kW).

Figure 7 shows the relative contribution of the control system on all the examined cases. Each shaded block shows the impact of the control applied on a macro-component divided by the total fuel impact associated with the malfunctions.

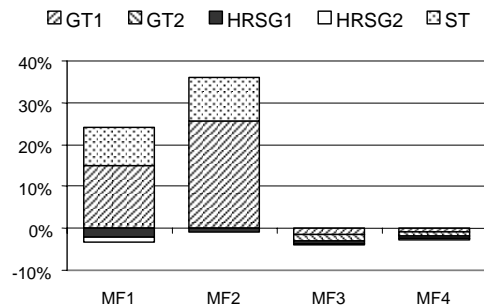

Figure 7. Effects of the control system on the macro-component

For cases MF1 and MF2, the anomaly occurs in the first gas turbine. The corresponding operating condition is not acceptable because the outlet turbine temperature differs from its set point (moreover the electric load is lower than desired, but the variation of the electric load is low and in an acceptable range). The control system operates in order to restore an acceptable operating condition. Here, the adjustment of only the GT1 gas turbine has been considered for simplicity. In reality, the two gas turbines are adjusted in order to produce the set electric load. Its intervention mainly affects the gas turbine itself (15% of the fuel impact) and the steam turbine (9% of the fuel impact). The second gas turbine is not affected as it is working correctly and no adjustment is necessary. The effect on the HRSGs is negative. This means that the exergy efficiency of these macro-components has increased slightly. In both cases, the effects are only propagated downstream since the anomaly has occurred in the upper macro-component.

For cases MF3 and MF4, significant upstream effects, quantified at about 3% for both cases, take place. In fact, the anomalies occur in

HRSG1 and in the steam turbine, respectively. In both cases, the electric load decreases so that the gas turbines have to increase their production. At the new operating conditions, the gas turbines are more efficient than at the reference condition, so that the contribution of the control system to the fuel impact of these components is negative. Small effects are also present in the first HRSG.

Malfunctions calculated by using equation (6) are the malfunctions induced by the behavior of components, i.e. the malfunctions, which this step aims to eliminate. Similarly, the costs of these malfunctions are obtained by substituting equation (6) into equation (8), such that:

$$\Delta F_{ji} = k_{pj}^* \cdot (\hat{k}_{ji} - k_{ji,ref}) P_{i,ref} \quad (9)$$

The cost of the product  $k_{pj}^*$  is calculated here at the reference condition, consistent with the hypothesis of slight deviations in fuels with respect to the reference condition. Equation (9) shows that the only considered effect is the variation of fuels with respect to the reference, i.e. the characteristic behavior of components (not flat exergetic efficiency maps).

TABLE 2A. COSTS OF THE MALFUNCTIONS [KW] BEFORE THE OPERATION OF THE CONTROL SYSTEM

Supplier	CC	C	T	A
Ambient	-1236	0	0	0
CC	0	0	-60	0
C	947	0	80	0
T	0	1056	0	0
A	0	0	0	0
Total cost of malfunctions				787 kW

TABLE 2B. COSTS OF THE MALFUNCTIONS [KW] WITHOUT THE EFFECTS INDUCED BY COMPONENTS (EQUATION (9))

Supplier	CC	C	T	A
Ambient	15	0	0	0
CC	0	0	73	0
C	38	0	3	0
T	0	1328	0	0
A	0	0	0	0
Total cost of malfunctions				1458 kW

Costs of the malfunctions in the components are shown in TABLE 2. In TABLE 2A, costs are calculated without eliminating the contribution of effects directly induced by the components as was done in TABLE 1B for the macro-components. The total cost of the malfunction is 787 kW, while in table 1 the contribution of the first gas turbine to the fuel impact was evaluated as 585 kW (the sum of the

first column in TABLE 1B). The difference is due to the different costs of the component products, determined by the more detailed structure considered in this step.

In TABLE 2B, the linear thermoeconomic model defined by equation (6) has been introduced in order to separate the contribution due to induced malfunctions.

## 6. Conclusions

A thermoeconomic procedure for the diagnosis of complex energy systems has been proposed in order to show the contributions of induced effects. The technique consists of a progressive elimination of the effects induced by the control system and the dependence of the behavior of the components on the operating conditions.

In particular, a combined cycle power plant has been considered in order to illustrate the application of the procedure as well as its limits. The results obtained by applying the procedure to four cases, each corresponding to a different anomaly, are summarized in figure 8.

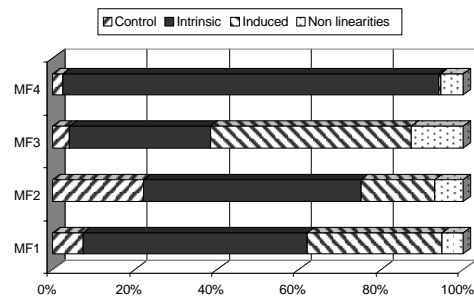

Figure 8. Main effects in the thermoeconomic diagnosis

The control system induces important effects on plants so that its contribution cannot be forgotten. Furthermore, the behavior of components can strongly depend on the operating condition and sometimes the effects induced by this dependence can be larger than the intrinsic effects (for example, as in case MF3).

The elimination of the former effects, using a linear thermoeconomic model, allows one to correctly locate the anomalies in simple cases. Nevertheless, when different anomalies simultaneously occur in a plant (as is the case in real situations), quantification of each contribution is crucial to distinguishing between true anomalies and induced effects.

## References

Diakunchak, I. S., 1992, "Performance Deterioration in Industrial Gas Turbines."



*Journal of Engineering for Gas Turbines and Power*. Vol. 114. pp. 161-168.

Frangopoulos C. A., 1987, "Thermoeconomic Functional Analysis and Optimization" *Energy - The Int. J.* 7, pp.563-571.

Lozano, M.A., Valero, A., 1993, "Theory of the Exergetic Cost. Energy" *The International Journal*, Vol. 18, No: 9, pp. 939-960.

Reini, M., 1994, "Analisi e Sviluppo dei Metodi Termoeconomici per lo Studio degli impianti di Conversione dell'Energia" Ph.D. Thesis. Università di Padova.

Seddigh, F., Saravanamuttoo, H. I. H., 1991, "A Proposed Method for Assessing the Susceptibility of Axial Compressors to Fouling" *ASME Journal of Engineering for Gas Turbines and Power*. Vol. 113, pp. 595-601.

Torres, C., Valero A., Serra L., Royo J., 1999, "Structural theory and Thermoeconomic Diagnosis. Part I: On Malfunction and Dysfunction Analysis" *ECOS 99*. June 8-10. Tokyo, Japan.

Tsatsaronis G., Pisa J. and LIN L., 1990, "The Effect of Assumptions on the Detailed Exergoeconomic Analysis of a Steam Power Plant Design Configuration - Part I: Theoretical Development. Part II: Results and Discussion" *Proceedings of FLOWERS 90*, Florence, May 28 - June 1.

Valero A., Lozano M. A. and Muñoz, M. A., 1986, "General Theory of Exergy Savings- Part I: On the Exergetic Cost, Part II: On the Thermoeconomic Cost, Part III: Energy Savings and Thermoeconomics" *Computer-Aided Engineering of Energy System*, pp. 1-21, A.S.M.E. W.A.M. 1986, AES-Vol. 2-3.

Valero A., Torres C., Serra L., 1992, "A General Theory of Thermoeconomics: Part 1. Structural Analysis" *ECOS92*. Zaragoza-Spain.

Valero, A., Torres, C., Lerch, F., 1999, "Structural theory and Thermoeconomic Diagnosis. Part III: Intrinsic and Induced

Malfunctions". *ECOS 99*. June 8-10. Tokyo, Japan.

Valero A., Correas L., Zaleta A., Lazzaretto A., Verda V, Reini M. and Rangel V., 2002, "On the Thermoeconomic Approach to the Diagnosis of Energy System Malfunctions. Part-2 Malfunction Definitions and Assessment" *ECOS02*. Berlin-Germany.

Verda V., Serra L., Valero A., 2001, "A procedure for filtering the induced effects in the thermoeconomic diagnosis of an energy system" ASME IMECE. New York.

Stoppato A., Lazzaretto A., 1996, "The Exergetic Analysis for Energy System Diagnosis" *AES. Thermodynamics and the Design, Analysis and Improvement of Energy Systems*. (Ed. Duncan, A. B.; Fiszdon, J.; O'Neal, D. and Den Braven, K.) ASME Book n° H01022, 1996, pp. 191-198.

Verda V., 2001, "Thermoeconomic Diagnosis of an Urban District Heating System based on Cogenerative Steam and Gas Turbines" Ph.D. Thesis. Polytechnic of Turin and University of Zaragoza.

Verda, V., Serra, L., Valero, A. 2001a, "The effects of the regulation system on the thermoeconomic diagnosis of a power plant. Part 1: The diagnosis procedure" *ECOS 2001*. July 4-6. Istanbul, Turkey.

Verda V., Serra L., Valero A., 2002, "Effects of the Productive Structure on the Results of the Thermoeconomic Diagnosis of Energy Systems". *International Journal of Applied Thermodynamic*. In publishing.

von Spakovsky M. R. and Evans R. B., 1990, "The Foundations of Engineering Functional Analysis (Part I and II)" *A Future for Energy, FLOWERS 1990*, Stecco and Moran, Florence.

Zaleta A. A., 1997, "Conceptos sobre el diagnostico y la evaluacion termoeconomica de turbinas de vapor" Ph.D. Thesis. University of Zaragoza (in Spanish).