

## Supercritical Fluid Parameters in Organic Rankine Cycle Applications

Sotirios Karellas, Andreas Schuster\*

National Technical University of Athens, Laboratory of steam boilers and  
thermal plants 9 Heroon Polytechniou, 15780 Athens Greece  
E-mail: sotokar@mail.ntua.gr

Technische Universität München, Institute of Energy Systems  
Boltzmannstr. 15, 85748 Garching, Germany  
E-mail: schuster@es.mw.tum.de

### Abstract

Nowadays, the use of Organic Rankine Cycle (ORC) in decentralised applications is linked with the fact that this process allows to use low temperature heat sources and offers an advantageous efficiency in small-scale applications. Many state of the art applications like geothermal and biomass fired power plants as well as new applications like solar desalination with reverse osmosis, waste heat recovery from biogas digestion plants or micro-Combined Heat and Power (micro-CHP) systems can successfully use the ORC process. The investigation of supercritical parameters in ORC applications seems to bring promising results in decentralised energy production. This paper presents the results from the simulation of the ORC process in normal and supercritical fluid parameters and discusses the efficiency variation in various applications.

*Keywords: Organic Rankine cycle (ORC), supercritical parameters, waste heat recovery.*

### 1. Introduction

The Organic Rankine cycle (ORC) is a Clausius Rankine cycle in which an organic working fluid is used instead of water-steam. In the last years it became quite popular in energy production processes, due to the fact that it gives the possibility to use heat of small supply rate and low temperature level. One of the main challenges when ORC is used in a process is the choice of the appropriate working fluid and of the particular cycle design with which maximum thermal efficiency can be achieved.

The ORC process is similar to the Steam process, which uses water as working fluid. The difference between water and an exemplary organic fluid is shown in *Figure 1*. The diagram shows the saturation lines and three isobars with the same pressure for water and organic fluid. It can be clearly seen, that the Critical Point (C.P.) of organic fluids is reached at lower pressures and temperatures compared with water. For numerous organic fluids the vapour saturation

line has a positive inclination. This allows the use of a recuperator for preheating the liquid working fluid by desuperheating the expanded vapour. In the state of the art applications which are discussed nowadays, saturated or slightly superheated vapour is expanded in the turbine. However, the investigation of supercritical fluid parameters is of high importance, since, as it will be discussed later, it leads to higher thermal efficiencies making these plants even more attractive for waste heat applications.

The main advantage of the supercritical process is the fact that the average high temperature in which the heat input is taking place is higher than in the case of the subcritical fluid process. Therefore, according to Carnot, the efficiency is higher. *Figure 2* shows the process of a sub- and supercritical ORC in a T-s-Diagram for a constant superheated vapour temperature. Even for constant superheated vapour temperatures, the heat input occurs at a higher

---

\* Author to whom correspondence should be addressed. schuster@es.mw.tum.de

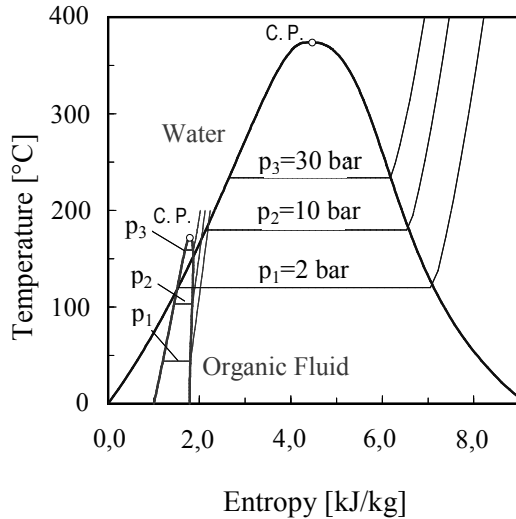

Figure 1. T-S Diagram for organic fluid and water.

average temperature level. In reality such big superheating as shown in the diagram would not be realized due to the tremendous heat exchange area needed due to the low heat-exchange coefficient for the gaseous phase.

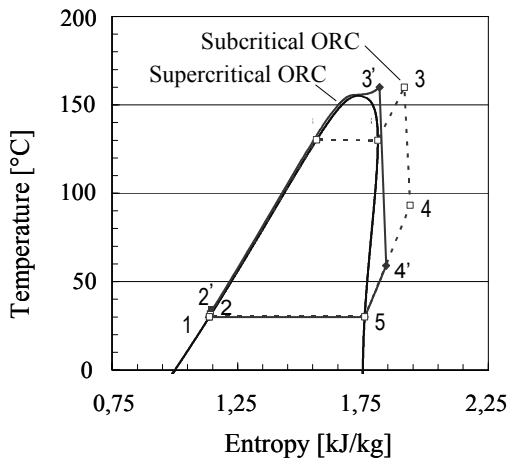

Figure 2. Sub- and supercritical ORC. Example of R245fa.

The thermal efficiency of the cycle is defined as follows:

$$\eta_{th} = \frac{P_{mech}}{\dot{Q}_{Thermal-oil}} \quad (1)$$

$P_{mech}$  is the net mechanical power produced with the ORC process (which will be assumed as equal the net electrical power). This power

output is analogue to the enthalpy fall in the turbine minus the enthalpy rise in the pump:

$$P_{mech} \sim (h_3 - h_4) - (h_2 - h_1) \quad (2)$$

The heat input to the ORC process is done usually with the help of the thermal oil and is analogue to:

$$\dot{Q}_{Thermal-oil} \sim (h_3 - h_2) \quad (3)$$

$h_1$ ,  $h_2$ ,  $h_3$  and  $h_4$  are the specific enthalpies according to Figure 2.

In the case of supercritical process, the enthalpy fall ( $h_3-h_4$ ) is much higher than in the subcritical one, whereas the feed pump's additional specific work to reach supercritical pressure, which corresponds to the enthalpy rise ( $h_2-h_1$ ), is very low.

Therefore, according to equation (1), the efficiency of the process is higher in the case of supercritical ORC parameters and this fact provides new frontiers in the investigation of ORC applications.

For the heat exchange system that transfers the heat from the heat source to the organic fluid, the efficiency is defined by the following equation:

$$\eta_{HEX} = \frac{\dot{Q}_{Organic\ fluid}}{\dot{Q}_{Heat-source}} \quad (4)$$

Finally, the efficiency of the whole system is defined as follows:

$$\eta_{System} = \frac{P_{mech}}{\dot{Q}_{Heat-source}} = \eta_{HEX} \cdot \eta_{th} \quad (5)$$

The above presented efficiencies will be used for the qualitative analysis of the ORC applications which will be described in this paper.

## 2. Cycle design

### 2.1 Organic Fluids

The first step when designing an ORC cycle application is the choice of the appropriate working fluid. The working fluids which can be used are well known mainly from refrigeration technologies. The selection of the fluid is done according to the process parameters of the cycle. According to the critical pressure and temperature, as well as the boiling temperature in various pressures, the appropriate fluid which provides the highest thermal and system efficiency has to be selected. However, the thermodynamic parameters of the fluid are not the only criteria to select them for efficient

applications. The Montreal Protocol, an international treaty for the protection of the stratospheric ozone layer, and the EC regulation 2037/2000 restrict the use of ozone depleting substances (European Parliament and council, 2004). Therefore, the cycle designer should always be aware of the global warming potential and the low ozone depletion of the working fluid before designing the ORC application. Finally, safety reasons like the maximum allowable concentration and the explosion limit should be considered.

In TABLE I four selected fluids and their characteristics are presented.

TABLE I. LIST OF WORKING FLUIDS.

Fluid	$T_c$ [°C]	$p_c$ [bar]	$T_{s, 1 \text{ bar}}$ [°C]	$p_s, 20^\circ\text{C}$ [bar]
R134a	101,1	40,6	-27,1	5,7
R227ea	101,7	29,3	-16,5	3,9
R236fa	124,9	32,0	-1,4	2,3
R245fa	154,1	36,4	14,9	1,2

The fluids are given in the order of rising critical temperature  $T_c$  and normal boiling temperature  $T_{s, 1 \text{ bar}}$ .  $p_c$  is the critical pressure and  $p_s$  the vapour pressure at 20°C.

The ORC process can work with a constant superheating of a few Kelvin. Higher superheating in order to avoid liquid in the exhaust vapour is not necessary, because the expansion ends in the area of superheated vapour in contrast to water.

Higher superheating of the vapour is favorable for higher efficiencies, but because of the low heat exchange coefficients this would lead to very large and expensive heat exchangers.

## 2.2 The turbine

The power range of ORC process applications can vary from a few kW up to 1 MW. The most commonly used turbines which are available in the market cover a range above 50 kW. Therefore, expanders in the power range below 10 kW have to be found. A very promising solution to this turbine market problem is to use the scroll expander. This expander works in a reverse way as the scroll compressor, which is a positive displacement machine used in air conditioning technologies. Scroll machines have two identical coils the one of which is fixed and the other is orbiting with 180° out of phase forming crescent-shaped chambers, whose volumes accelerate with increasing angle of rotation.

Another promising machine for the expansion of the working fluid is the screw type compressor.

Rotary screw compressors are also positive displacement machines. The mechanism for gas compression utilises either a single screw element or two counter rotating intermeshed helical screw elements housed within a specially shaped chamber. As the mechanism rotates, the meshing and rotation of the two helical rotors produces a series of volume-reducing cavities. Gas is drawn in through an inlet port in the casing, captured in a cavity, compressed as the cavity reduces in volume, and then discharged through another port in the casing.

Screw type compressors can work in the reverse direction also as expanders providing similar efficiencies. The effectiveness of the screw mechanism is dependent on close fitting clearances between the helical rotors and the chamber for sealing of the compression cavities.

## 3. Applications of the organic Rankine cycle

The use of waste heat from a process is the main application of the Organic Rankine Cycle. *Figure 3* shows the general scheme of waste heat recovery by means of ORC process. More specifically, waste heat is transferred via a thermal oil into the organic medium in the evaporator. The organic medium is then expanded in the turbine.

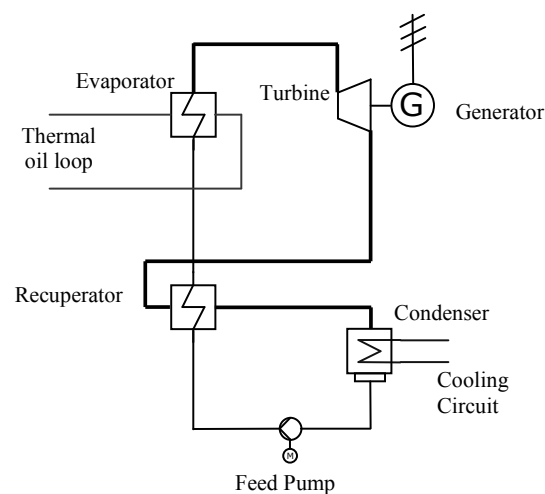

Figure 3. Main components of the ORC.

In this chapter three different types of ORC applications will be discussed: The use of waste heat from biomass combustion, internal combustion engines and geothermal process.

### 3.1. Biomass combustion

Combustion is the most common process for energy production from this renewable fuel. The fact that it is CO<sub>2</sub>-free has led the countries to the financial support of biomass combustion technologies. Some countries like for example Germany support extra the use of innovative technologies such as ORC process. Therefore,

many examples of ORC powered Combined Heat and Power plants are working in central Europe like Stadtwärme Lienz Austria 1000 kW<sub>el</sub>, Sauerlach Bavaria 700 kW<sub>el</sub>, Toblach South Tyrol 1100 kW<sub>el</sub>, Fußach Austria 1500 kW<sub>el</sub> (Duvia et al., 2002; Obernberger et al., 2002).

The main reason why the construction of new ORC plants increases is the fact that it is the only proven technology for decentralized applications for the production of power up to 1 MW<sub>el</sub> from solid fuels like biomass. The electrical efficiency of the ORC process lies between 6-17 % (Karl, 2004).

However, even if the efficiency of the ORC is low, it has advantages, like the fact that the system can work without maintenance, which leads to very low personnel costs. Furthermore the organic working fluid has, in comparison with water, a relatively low enthalpy difference between high pressure and expanded vapour. This leads to higher mass flows compared with water. The application of larger turbines due to the higher mass flow reduces the gap losses compared to a water-steam turbine with the same power. The efficiency of an Organic Rankine Cycle turbine is up to 85 % and it has an outstanding part load behavior (Turboden).

The exhaust gas from biomass combustion has a temperature of about 1000 °C. For the use of the exhaust heat in the ORC process, the working fluid which is used in most of the biomass applications is octamethyltrisiloxane (OMTS). Drescher et al. (2007) discusses the use of other organic fluids and calculates an efficiency rise of around three percentage points in the case where Butylbenzene is used.

### 3.2. Waste heat recovery from IC engines

A typical example of ORC powered waste heat recovery units comes from the field of Internal Combustion (IC) Engines. ORC process

can be found for example in biomass digestion plants. In this case, biogas coming out from the biomass digester is burned in an internal combustion engine. The waste heat from this engine operates the ORC cycle. Depending on the size of the digestion plant and the standard of the insulation of the plant, the thermal need is between 20 ... 25 % of the waste heat of the motor (Fachagentur Nachwachsende Rohstoffe, 2004). According to the low temperature level, the digester can be heated with the cooling water of the motor and the turbocharger. For driving the ORC the heat of the exhaust gas can be used.

A coupling of the ORC process with internal combustion engines can be also found in

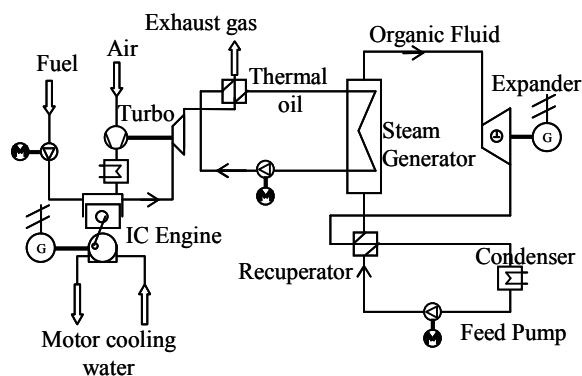

Figure 4. Schematic representation of waste heat recovery for combustion engines.

first prototypes for on-road-vehicle applications, where the condition for waste heat is variable. Figure 4 shows the schematic setup of such a system.

As shown in the figure, the combustion air is first compressed and then, after being cooled ends at the combustion chamber, where the fuel is being burned. The exhaust gas which leaves the motor at a temperature around 490 °C transfers the needed heat to the thermal oil, which preheats, evaporates and superheats the organic fluid. The superheated organic vapour is expanded in a scroll or a screw type expander, which, coupled with a generator, produces electric power. Due to the fact, that the used working fluid is after the expansion still in the area of superheated vapour, it is used in the recuperator in order to preheat the liquid working fluid. After being desuperheated, the vapour is condensed in a condenser which is cooled back with air or water from an evaporative cooler. The feed pump raises the pressure of the working fluid and forces the fluid again through the heat exchangers.

As working fluid for the calculations, the fluorohydrocarbon R245fa was chosen. The fluid has a very broad application range. It is used as foaming agent, refrigerant and filling for thermosiphons as well as working fluid for Organic Rankine Cycle for heat recovery and bottoming cycles (Honyewell, 2000). Due to the negative inclination of the vapour saturation line (see Figure 2) between evaporation (2-3') and condensation (5-1), the sensible heat which rests in the expanded vapour (4) can be used for preheating the liquid working fluid.

The assembly of the system is the same in the cases of sub- and supercritical fluid parameters. Figures 5 and 6 show the Q-T diagrams of sub- and supercritical ORC process in waste heat recovery from an internal

combustion engine. The exhaust gas heats the thermal oil which temperature reaches the value of about 240°C. In the subcritical case, the preheating, evaporation, and superheating area are clearly distinguished, when, on the other hand, in the case of supercritical parameters this does not happen. This fact has an effect on the exergy losses of the systems. In the second case the thermodynamic efficiency is better and this can be also observed in *Figures 5 and 6*, since in

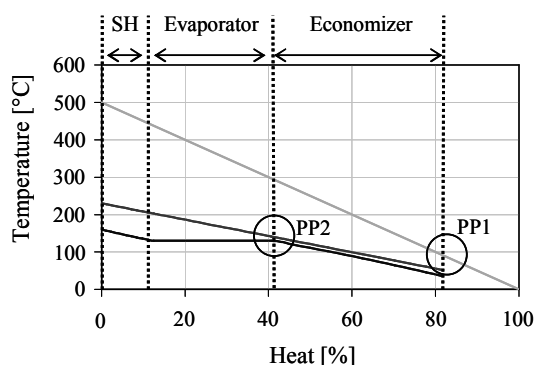

Figure 5. *Q-T diagrams of subcritical ORC waste heat recovery process.*

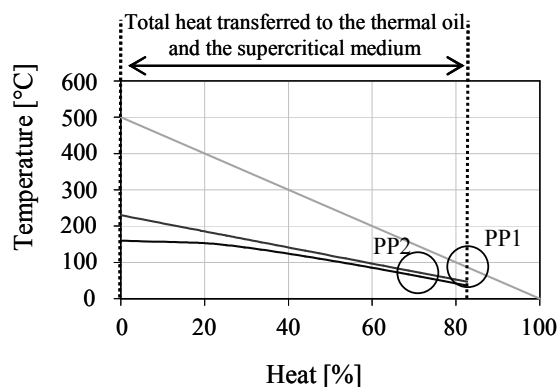

Figure 6. *Q-T diagrams of supercritical ORC waste heat recovery process.*

the second diagram, the area between the thermal oil curve and the organic fluid curve is much smaller than in the first one.

In both diagrams the minimum temperature difference between the thermal oil and the exhaust gas (pinch point PP1) was kept constant at 40 K. The second pinch point linked with the minimum temperature difference between the thermal oil and the organic medium (PP2) was also kept constant at the value of 10 K. The thermal efficiency as well as the system efficiency for subcritical and supercritical fluid parameters are presented in TABLE II.

As presented in TABLE II, the calculations proved that the thermal efficiency of the Organic Rankine cycle is more than one percentage point

TABLE II. EFFICIENCIES OF SUB- AND SUPERCRITICAL ORC PROCESSES COMBINED WITH IC ENGINES.

	Subcritical	Super-critical	relative efficiency gain
$\eta_{Th}$	14,62 %	15,97 %	+ 9,2 %
$\eta_{System}$	11,27 %	12,72 %	+ 12,8 %

higher in the case of supercritical fluid parameters as it has been discussed when presenting equation (1). The total efficiency of the system is also about one percentage point better in the case in which supercritical fluid parameters are used. Therefore, the total efficiency of the system is about 13% higher in the case of supercritical fluid parameters. This result is linked with two facts. First of all, with the fact that, as already mentioned, the thermodynamic efficiency is better in the case of supercritical ORC and the second is that in the supercritical process more heat can be transferred from the exhaust gas into the thermal oil when the pinch point (PP1) difference between them is the same. The total efficiency of the system can be improved further if the internal efficiency of the pump is better. For the above mentioned calculations a pump efficiency of 75 % has been taken into consideration.

### 3.3. Geothermal plants using ORC

Another case where the ORC technology is applied is its combination with the heat coming from geothermal heat sources. Conventional power station technology is not suitable for heat sources with temperatures between 80°C and 160°C. The Kalina process which is a process using a mixture of ammonia and water seems to be the only alternative to ORC. An example of a

geothermal plant using the ORC process is the plant Neustadt-Glewe in Germany (Broßmann et al.), which was the first geothermal power plant in Germany (Lund, 2005). This plant is a simple Organic Rankine Cycle Plant which uses n-Perfluoropentane ( $C_5F_{12}$ ) as working fluid. It uses water of approximately 98°C located at a depth of 2.250 m and converts this heat to 210 kW electricity by means of an Organic-Rankine-Cycle (ORC) turbine. Another well known geothermal plant using ORC process is the Altheim Rankine Cycle Turbogenerator in the upper Austrian city Altheim. This plant produces

1 MWel power and supply heat to a small district heating system ([www.geothermie.de](http://www.geothermie.de)). The thermal power input from the geothermal water is equal to 12,4 MWth.

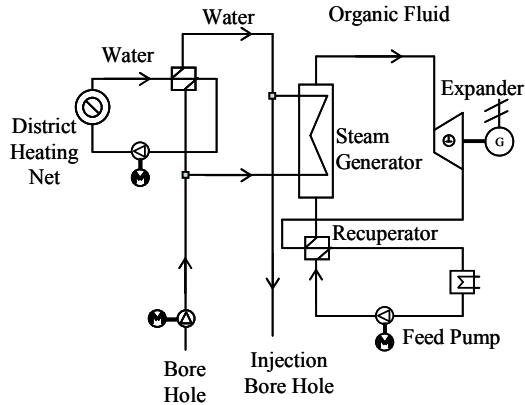

Figure 7. Geothermal ORC plant.

The Geothermal plant which has been taken into consideration during the calculations of the ORC process is shown in Figure 7. As it can be seen in this figure, hot water coming from the earth is pumped and provides heat to a heat exchanger for the district heating net. Another part of it bypasses the heating net and is used as heat sources for the Organic Rankine Process.

The cold water is returned to the earth. A difference between the ORC used for the geothermal plant and the processes described before is that in the case of geothermal plants no thermal oil is needed. The hot water coming from the earth has a temperature of around 90°C-160°C and provides its heat directly to the ORC fluid.

The efficiency of the geothermal power plant has been calculated in various cases.

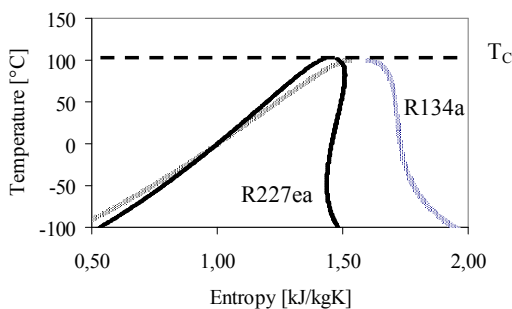

Figure 8. R227ea and R134a saturation curves.

Two working fluids have been taken into consideration: the working fluids R134a and R227ea. These two working fluids, according to TABLE I are suitable for such plants, since they both have a critical temperature of around 100°C.

The form of their saturation lines is also of great interest since the one is with an inclination (227ea) and the other without (see figure 8)

The heat source temperature in the calculations varied between 110 °C and 160 °C.

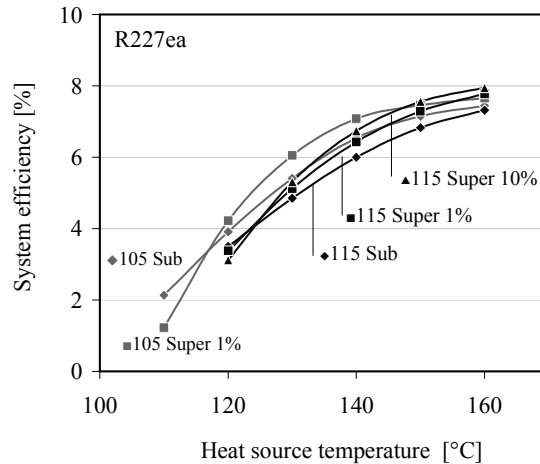

Figure 9. System efficiency for sub- and supercritical cycles (R227ea).

In Figure 9 and Figure 10 the variation of the system efficiency in subcritical and supercritical fluid parameters is presented.

Two cases of superheated vapour temperature are presented (105°C and 115°C). In the case of supercritical calculations, the cases of 1% and 10% pressure above the critical pressure have been examined. The efficiency of the turbine was set to 80 %, the efficiency of the feed pump to 70 %, condensation temperature to 30 °C and the temperature difference at the pinch point of the recuperator to 5 K. Pressure losses are neglected.

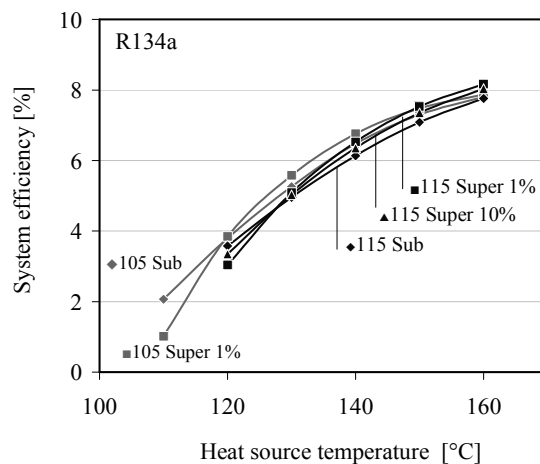

Figure 10. System efficiency for sub- and supercritical cycles (R134a).

Concerning the thermal efficiency of the ORC process, the results from the calculations are presented in TABLE III.

In TABLE III, in the cases in which the efficiency is typed bold, the expansion in the turbine ends in the two-phase area (point 4 in Figure 1), so no recuperator can be used. That is the reason why the thermal efficiency in these

TABLE III. THERMAL EFFICIENCY FOR SUB- AND SUPERCRITICAL FLUID PARAMETERS.

R227ea					
	sub 35,5 bar	super (1%) 29,5 bar	super (10%) 32,2 bar	super (20%) 35,1 bar	super (30%) 38,0 bar
$T_{\text{vapour}}$ [°C]	$\eta_{\text{Th}}$ (%)	$\eta_{\text{Th}}$ (%)	$\eta_{\text{Th}}$ (%)	$\eta_{\text{Th}}$ (%)	$\eta_{\text{Th}}$ (%)
105	11,21	10,52	<b>8,60</b>	<b>8,11</b>	<b>7,84</b>
115	12,14	12,17	11,85	11,00	<b>9,77</b>
125	12,9	13,19	13,16	12,95	12,52
135	13,58	14,02	14,13	14,13	14,00
R134a					
	sub 35,9 bar	super (1%) 40,6 bar	super (10%) 48,7 bar	super (20%) 48,7 bar	super (30%) 52,8 bar
$T_{\text{vapour}}$ [°C]	$\eta_{\text{Th}}$ (%)	$\eta_{\text{Th}}$ (%)	$\eta_{\text{Th}}$ (%)	$\eta_{\text{Th}}$ (%)	$\eta_{\text{Th}}$ (%)
105	10,44	<b>10,34</b>	<b>8,7</b>	<b>7,97</b>	<b>7,61</b>
115	11,56	11,29	<b>11,04</b>	<b>10,67</b>	<b>9,84</b>
125	12,45	12,5	12,3	11,85	<b>11,50</b>
135	13,22	13,46	13,45	13,27	12,94

cases of supercritical parameters is much lower than the subcritical ones, in which a recuperator is used. The high content of liquid in the exhaust vapour can be harmful for the turbine blades.

It can be seen, that the thermal efficiency declines with rising supercritical pressure beginning from an optimum pressure. This effect can be explained with the characteristics of the isobars in the T-s-diagram. The change from sub- to supercritical rises the average upper process temperature. A further rise of the pressure at given live vapour temperature moves the starting point of the expansion to the left side, so the enthalpy difference in the turbine declines, whereas the enthalpy difference, that has to be cooled back in the condenser is nearly constant.

In TABLE III it can be also observed that the use of supercritical fluid parameters is not always followed by better thermal efficiencies, which is caused by lower internal heat transfer between exhaust gas and liquid working fluid (see *Figure 2*) in the supercritical process.

However, due to the fact that, as discussed in the previous chapter, in the supercritical process more heat can be transferred from the exhaust gas into the thermal oil when the pinch point (PP1) difference between them is the same, the system efficiency is better in the case of supercritical fluid parameters, even if the thermal efficiency in some cases is lower (see *Figures 9 and 10*).

#### 4. Conclusions

The Organic Rankine Cycle is nowadays the only proven technology in the power range of a few kW up to 1MW. Various applications are using this technology in order to utilise heat of low temperature level. The main task of the designers of such applications is to choose the right working fluid and the right thermodynamic properties of the working fluid in order to optimize the power output and the efficiency of the system. This paper has shown that supercritical fluid parameters can maximise the efficiency of the system, since they provide systems with better thermodynamic efficiency. The use of supercritical fluid parameters could also be applied in modern applications like thermal desalination (Schuster et al., 2005) or micro CHP.

#### Nomenclature

$h$	Enthalpy	[kJ/kgK]
$P$	Power	[kW]
$p$	Pressure	[bar]
$Q$	Heat	[kWh]
$s$	Specific entropy	[kJ/kgK]
$T$	Temperature	[°C]

#### Greek letters

$\eta$	Efficiency	[%]
--------	------------	-----

#### subscripts

$c$	Critical
$HEX$	Heat Exchange system
$mech$	Mechanical
$s$	Saturation
$th$	Thermal

#### Abbreviations

C.P.	Critical Point
CHP	Combined Heat and Power
EC	European Commission
IC	Internal Combustion
ORC	Organic Rankine Cycle
OMTS	OctaMethylTrisilOxane
PP	Pinch Point
SH	Super Heater

#### References

Broßmann, E., Eckert, F., Möllmann, G.: *Technical concept of the geothermal power plant Neustadt-Glewe. (technisches Konzept des geothermischen Kraftwerks Neustadt-Gelewe)*. Berlin, Germany; [http://www.geothermie.de/gte/gte43/technisches\\_konzept\\_des\\_geotherm.htm](http://www.geothermie.de/gte/gte43/technisches_konzept_des_geotherm.htm) (in German)

- Drescher I., Brüggemann D. (2007): *Fluid selection for the Organic Rankine Cycle (ORC) in biomass power and heat plants*, Applied Thermal Engineering 27 (2007) 223-228.
- Duvia, A., Gaia M. (2002): ORC plants for power production from 0,4 MWe to 1,5 MWe: technology, efficiency, practical experiences and economy. 7<sup>th</sup> Holzenergie Symposium, Zürich, Switzerland, 18. October 2002.
- European Parliament and Council (2004): *Regulation (EC) No 2037/2000 on substances that deplete the ozone layer*, March 2004.
- Fachagentur nachwachsende Rohstoffe e.V. (2004) (ed.): *Assistance for Biogas production and use (Handreichung Biogasgewinnung und –nutzung)*. Leipzig. (in German)
- Honeywell(2000):*Genertron®245fa.Applications Development guide*. Honeywell Fluorine Products, Morristown, USA, [http://www.geothermie.de/gte/gte3637/altheim\\_gaia.htm](http://www.geothermie.de/gte/gte3637/altheim_gaia.htm)
- Karl, J. (2004): *Decentralised energy systems, new technologies in liberalised energy market Dezentrale Energiesysteme , (Neue Technologien im liberalisierten Energiemarkt)* Oldenbourg Wissenschaftsverlag, München,. (in German)
- Lund, J (2005). W.: *Combined Heat and Power plant Neustadt-Glewe, Germany*. GHC, Bulletin June.
- Obernberger, I., Thonhofer, P., Reisenhofer E. (2002):*Description and evaluation of the new 1000 kWel Organic Rankine Cycle process integrated in the biomass CHP plant in Lienz, Austria*. Euroheat& Power, Volume 10/2002.
- Schuster, A., Karellas, S., Karl, J. (2005): *Simulation of an innovative stand-alone solar desalination system with an Organic Rankine Cycle*. SIMS 2005, 46<sup>th</sup> Conference on Simulation and Modeling, Trondheim, Norway, 13-14 October 2005.
- Turboden High Efficiency Rankine for Renewable Energy and Heat Recovery* available at: <http://www.turboden.it/orc.asp> (Date of access 25.01.06)