

# Mixer with Secondary Venturi: An Invention for the First-Generation LPG Kits

Muji Setiyo\* and Budi Waluyo

0000-0002-6582-5340, 0000-0002-5656-592X

Department of Automotive Engineering, Faculty of Engineering, Universitas Muhammadiyah Magelang, Magelang 56172, Indonesia

## Abstract

Engine performance is one of the problems in LPG applications for vehicles with first-generation converter kits. Therefore, this paper presents the development of a mixed prototype to be applied to LPG fueled vehicles, using first-generation converter kits (converters and mixers). Development for the LPG prototype started with design, prototyping, ending with testing on the vehicles. The prototyping process consisted of design and machining activities, carried out with Pro-Eng software and a turning machine respectively. Furthermore, the prototype mixer was tested on a 1500 cc engine, as the output torque and power were measured using a chassis dynamometer with the standardized test method. The results of this study indicate that the mixer with secondary venturi shows better output torque and power than a standard mixer at almost all daily speeds for public fleet and private vehicles. In conclusion, mixer with a secondary venturi is feasible for implementation in public transport that deals with the heavy load.

*Keywords:* LPG fueled vehicle, converter, mixer, secondary venturi

\* Corresponding author

Muji Setiyo

[setiyo.muji@ummgl.ac.id](mailto:setiyo.muji@ummgl.ac.id)

Address: Department of Automotive  
Engineering, Faculty of Engineering,  
Universitas Muhammadiyah  
Magelang, Indonesia

Tel: +62293 324945

Research paper

Manuscript

Received 06.12.2018

Revised 02.03.2019

Accepted 27.03.2019

Doi: 10.30939/ijastech..492830

## 1. Introduction

Indonesia's primary energy consumption has increased by more than 50% from 2000 to 2010. However, oil production which supports the majority of energy needs dropped from peak production of 1.6 million barrels per day to barely 861,000 barrels per day in 2012. Concerns have also risen, as oil reserves have decreased by more than 1.9 billion barrels since 1992, representing the sharpest decline in Asia. Considering the projection period 2016-2050, prices for all types of energy are forecasted to increase with varying growth, dependent on the development of the price of each kind of energy at this time. Coal, natural gas, diesel oil, fuel oil, and biomass prices are forecasted to grow 1.2%, 0.9%, 2.3% and 1.2% per year respectively [1].

In the transportation sector, growth in the number of vehicles, availability of fuel, and the increase in fuel prices in Indonesia are strategic issues that must be resolved by the Government. Data from the Central Bureau of the Statistics Republic of Indonesia presented that in 2016 the number of vehicles in Indonesia surpassed 129 million units, including passenger vehicles, buses, trucks, and motorbikes [2]. Of this total, more than 14 million units are potential passenger vehicles to be converted to LPG/LGV or CNG, by a bi-fuel

or full dedicated system.

LPG has a long history as a vehicle fuel, although experiments using LPG began around 1910. The first experiment was applied to vehicles in California, United States in 1950, when the Chicago Transit Authority ordered 1,000 buses with LPG fuel, with Milwaukee converting 270 fuel oil ran taxis to LPG. Subsequently, LPG became one of the most popular alternative fuels for vehicles, starting from the United States and extending into Europe, Asia, and other continents [3].

LPG is obtained from hydrocarbons produced from refining crude oil and processing of natural gas, with the main components dominated by propane ( $C_3H_8$ ) and butane ( $C_4H_{10}$ ) [4]. LPG has an energy content of 46.23 MJ/kg and 26 MJ/l, which is slightly higher than gasoline which stands at 44.4 MJ/kg and 34.8 MJ/l [5]. The energy content of LPG per mass unit is relatively higher than gasoline, although per unit volume is lower. For this reason, the same tank size of vehicles run by LPG, cover a shorter distance than those run on gasoline.

### 1.1. Performance of LPG vehicles

Initially, vehicles driven by LPG only produced 80-90%

power compared to vehicles run on gasoline [6]–[8]. Development of LPG kits through research has seen power losses due to LPG properties reduced. The power and emissions of LPG vehicles were improved by applying the ignition timing regulator, modifying engine components and increase of compression ratios [9]–[14]. Other efforts were also carried out by managing LPG temperatures on the fuel rails [15] and by modifying valve lifters combined with injection duration [16]. Presently, LPG kits have achieved Liquid Phase Direct Injection (LPDI), which is equivalent to GDI. Losses due to intakes system have been successfully eliminated, with lower emissions due to LPG properties that have low emission characteristics.

### 1.2. Growth of LPG vehicles

Every year, the World LPG Association (WLPGA) issues an annual report on the number of LPG vehicles operating worldwide, fuel consumption, and the number of refueling sites. Their 2018 data indicated that the number of LPG run vehicles globally is estimated at over 27 million, supported by more than 78 thousand refueling sites, with global consumption of more than 26 million tons [17], which is a slight increase from 2017 [18]. Of the ten countries observed by WLPGA, Turkey ranked first in the number of vehicles. However, South Korea ranked first in consumption (The latest data on LPG vehicles in the world are presented in Table 1). The promotion policy of LPG to replace gasoline differs across countries, as the issue of price, availability, and environment are often critical factors surrounding ease of conversion. Countries that have successfully promoted LPG to replace gasoline, also provide reasonable incentives.

Table 1. Top ten LPG market in the world, 2017 [17]

Country	Consumption (thousand tonnes)	Vehicles (thousand)	Refuelling sites
Korea	3314	2122	2037
Turkey	3116	4617	10297
Russia	3100	3000	4900
Poland	1915	3082	6287
Italy	1675	2309	3979
Ukraine	1503	2500	3800
Thailand	1320	1065	1450
Mexico	1101	420	2150
China	1007	168	560
Japan	728	200	1406
Rest of the world	8056	7653	41401
<b>World</b>	<b>26835</b>	<b>27136</b>	<b>78267</b>

### 1.3. Status of LPG vehicles in Indonesia

In Indonesia, LPG for vehicles application started in 1988 for Taxis in Jakarta. However, until now, the growth has not been clearly seen. In 2007, the use of LPG for vehicles with the name of "Vigas", was promoted again by

the government [19]. Notably, Indonesia has successfully carried out a mega project to replace kerosene with LPG, for households and small industries through the "blue sky program" [20]. Till date, the Government has continued to promote Vigas, by providing free converter kits for public fleets. However, public fleets drivers have complained about the power of their cars, hence leading to LPG use decline and further to return to gasoline. Notably also is the fact that available converter kits, are not fully compatible with average old vehicles.

In the previous work, the authors have produced a mixer with venturi area that can be adjusted to the condition of the engine [21]. Some weaknesses in partial loads can be reduced with this new mixer design. However, it is still not suitable to be applied to vehicles when heavy load condition (for example on slopes or acceleration with a lot of loads). Given that Indonesia is a country that has many mountains, LPG vehicles with first-generation converter kits (converter and mixer), it is necessary to develop a mixer that is able to supply LPG according to engine load, especially when heavy loads. Therefore, this paper reports the results of developing a mixer with secondary venturi, from design, prototyping, and testing of prototypes to vehicles.

## 2. Method

### 2.1 Prototyping

The prototyping process involved design and machining activities. Design activities were carried out with Pro-Eng software, while machining activities were carried out with a turning machine. In this study, the main material for the mixer was Teflon, which was suitable for machining. Photographic view of prototyping is presented in Fig. 1.

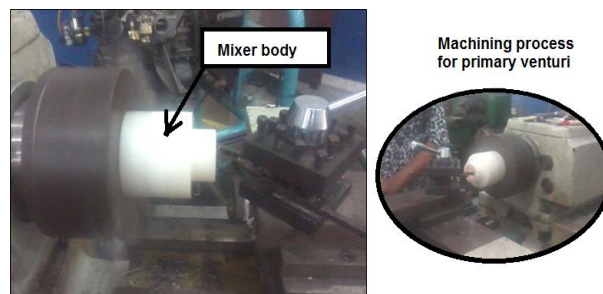

Fig. 1. Photographic view of mixer prototyping using a turning machine

### 2.1 Prototype testing

After the prototyping process, the activity continued with testing of the prototype on a chassis dynamometer Hofmann Dynatest Pro. A Stefanelli 50 HP vaporizer was also installed on a 1500cc engine, modified for bi-fuel experiences, making it possible to operate both LPG and gasoline alternately. LPG used during the research was obtained from Pertamina (Indonesian State-Owned

Company), with a mixture of propane and butane. Testing of torque and power was carried out at room temperature, which was not conditioned. Furthermore, to help cool the engine, an electric blower was powered in front of the car.

The testing mode was conducted with "P-Max Program" to get the curve of torque and power. The car was placed on a dynamometer with a trained driver, accelerating from rest to maximum speed by changing gears smoothly but quickly. The specification of the engine used in this study is described in Table 2. Acceleration was carried out until the maximum power was exceeded, after which the clutch was released, leaving the car engine to rotate freely. With the return of the engine to the stationary rotation, power loss was however recorded. The photographic view of the engine testing by a chassis dynamometer is shown in Fig. 2.

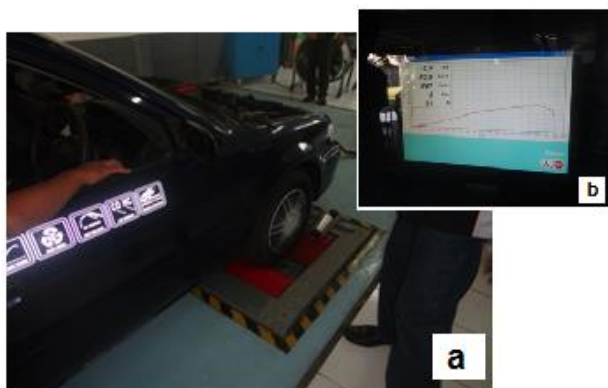

Fig. 2. Testing on chassis dynamometers: (a) car placement and (b) curve display during engine running

Table 2. Engine specification

Engine manufacturer	: Toyota
Engine code	: 5A-FE
Cylinders	: Inline 4
Capacity	: 1498 cc
Bore × Stroke	: 78.7 × 77 mm
Valve mechanism	: DOHC, 4 valves per cylinder
Maximum power output	: 77 kw @ 6000 rpm
Maximum torque	: 135 Nm @ 4800 rpm
Compression ratio	: 9.8:1
Fuel system	: EFI

### 3. Result and Discussion

#### 3.1. Mixer Prototype

The mixer developed includes two main parts namely, mixing house (A) in a cylindrical shape and a vacuum regulating cone (B). The mixing house is equipped with an inlet nipple for LPG from the evaporator, while the vacuum regulating cone includes a cone body, a spring, a sliding shaft, and a cone holder. The design of the mixer with a

secondary venturi compared to the standard mixer is presented in Fig. 3 as follows.

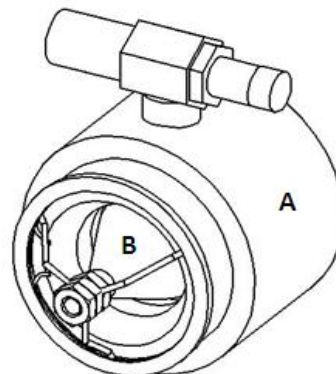

Fig. 3. Mixer with secondary venturi developed in this study

The technical summary which is the advantages of the new mixer includes; 1) The venturi area changes automatically depending on the vacuum and engine behavior. When idle, the venturi area is small, but on high speed, the venturi areas increases according to the level of vacuum; 2) When the engine works under heavy load (wide throttle valve and low engine speed), the vacuum level at the mixer will decrease, while the cone reduces the venturi hole so that the vacuum will rise. Subsequent increase in the vacuum will further increase the flow of LPG so that the engine torque will increase; 3) The level of cone spring tightness can be adjusted by turning the adjusting bolt externally, without removing the mixer from the throttle body (Figure 4).

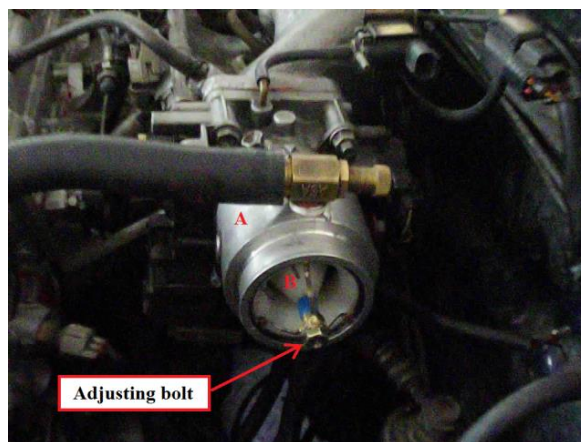

Fig. 4. Installing a mixer on the throttle body, spring tightness can be adjusted by turning the adjusting bolt from the outside of the mixer.

#### 3.2. Detail Construction

Mixer with secondary venturi developed, includes mixing house (10), a primary venturi (20), a secondary

venturi (30), and a locking part (40), as shown in Fig. 5 as follows.

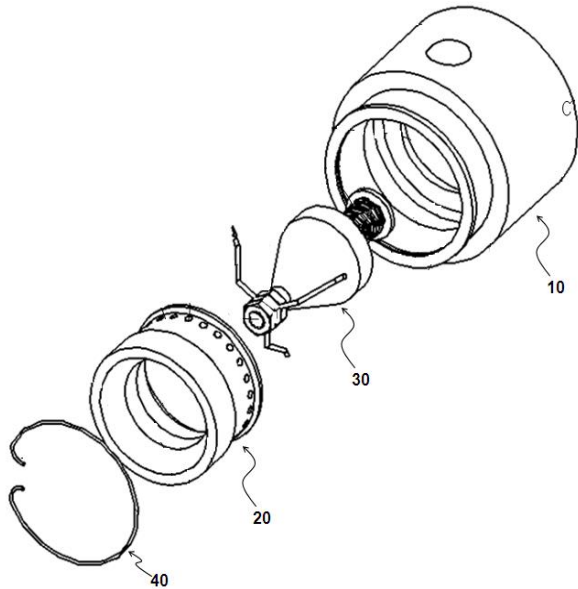

Fig. 5. Detail construction of mixer with secondary venturi

The mixing house (10) was formed by a mixing body having at least one gas inlet hole and at least one bolt hole, for connection of the mixer to the throttle body. Primary venturi (20) is cylindrical in shape found inside the mixing house, similar to the primary venturi found in the old mixer. Secondary venturi (30) includes a vacuum regulating cone

that has a slide hole and a spring mount, a sliding rod that penetrates the slid hole in the vacuum regulating cone, two fastening nuts, at least three supporting braces, a return spring, and a damper mounted between the cone and fastening nut. The locking part is a ring which has an indentation at both ends, (40) and attached to the groove of the mixing mouth.

The mixing house was made up of aluminum alloy, while primary venturi and vacuum regulating cones were made up of aluminum alloys and reinforced plastic materials. Gliding rods are made up of metal materials that have good sliding properties, corrosion resistant and wear resistant. The locking part was made up of materials that have spring properties. A mixer with a secondary venturi that matches this design, where the hardness of the return spring and vacuum adjusting cone clearances can be adjusted by adjusting the length of the sliding rod through the fastening nut or replacement of the rubber damper length.

### 3.3. Engine Torque and Power

The engine torque and power of the mixer with the secondary venturi, compared to the standard mixer on the chassis dynamometer are presented in Fig. 6. The red curve shows the performance of the mixer with secondary venturi, while the black curve shows the performance of the mixer without secondary venturi. Engine torque is measured in N.m (right) and engine power is measured in hp (left).

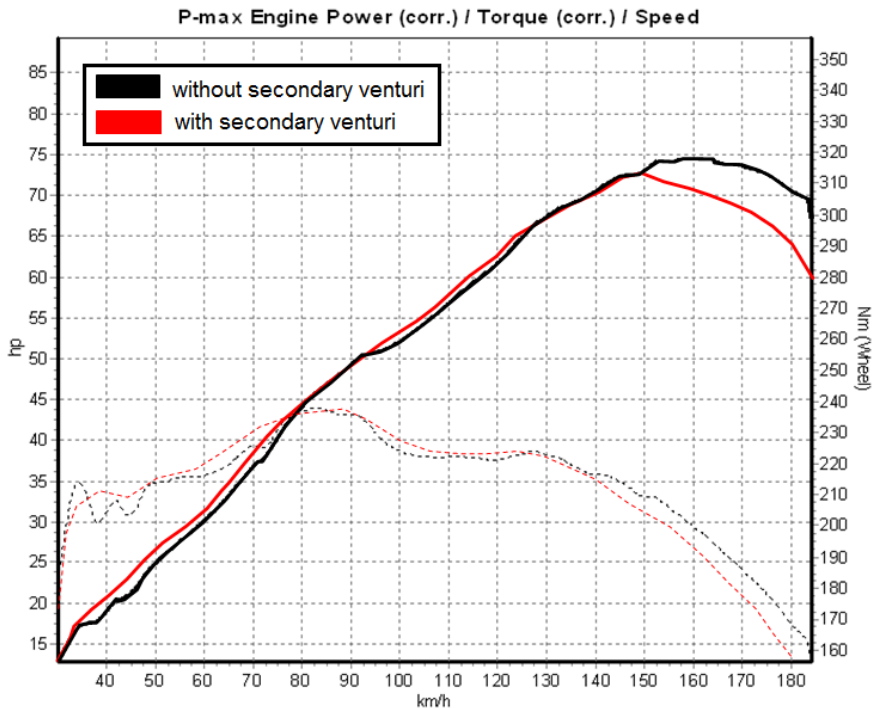

Fig. 6. Output torque and power of mixer with secondary venturi compared to the standard mixer

From Fig. 6, a mixer with a secondary venturi shows a better output torque and power than a standard mixer at vehicle speeds below 140 km/h. However, for the vehicle at above 140 km/h, standard mixers produce higher performance. Although, in daily vehicle applications, where the vehicle speed does not exceed 100 km/h, a lower pick power at vehicle speeds above 140 km/h will not be a problem.

Results of the test show that the cone mounted inside the mixer worked properly when the cone was able to regulate the vacuum. During acceleration under heavy load, the cone was able to provide an accurate vacuum signal to the LPG vaporizer providing a better LPG-air mixture. Observations during the study showed that the mixer area can change according to vacuum level and engine speed. However, at low engine speed, the cone moves forward to narrow the venturi. Further observation showed that at high engine speed, the cone moves backward to expand the venturi, however for heavy load (under wide throttle valve and low engine speed), the cone moves to narrow the venturi. As a result, the vacuum increases as the LPG flow increases to enrich the mixture.

#### 4. Conclusion

From a series of experiments conducted, we found that mixers with secondary venturi were able to improve the performance of LPG vehicles, especially during acceleration. With opening of the throttle at low manifold vacuum, the mixer is able to make self-adjustments for additional fuel supply. When the engine operates dynamically, the cone moves forward and backward automatically to regulate the venturi area. As regards the holistic output, we have not been able to report the emissions produced (g/km) through emission test according to the standardized test method. However, the results of this development are promising, as regards improvement of LPG vehicle performance with first-generation converter kits, and are feasible for application in public transport that deals with the heavy load.

#### Acknowledgment

This article is an output of INSINAS (multi-year research) funded by the Ministry of Research and Technology of the Republic of Indonesia. The researchers thanked the Department of Ototronik VEDC Malang and the Automotive Laboratory of Universitas Muhammadiyah Magelang for the support of the equipment and services provided. Prototype presented in this article have also been granted patents from the Ministry of Law and Human Rights of the Republic of Indonesia with patent number of IDS000001799.

#### References

- [1] E. Prasodjo *et al.*, *Indonesia Energy Outlook 2016*. Jakarta: Indonesian National Energy Council, 2016.
- [2] Central Bureau of Statistics Republic of Indonesia, "The Number of Motorized Vehicles by Type, 1949-2016," 2018. [Online]. Available: <https://www.bps.go.id/linkTabelStatis/view/id/1322>. [Accessed: 08-Aug-2018].
- [3] M. R. Werpy, A. Burnham, and K. Bertram, "Propane Vehicles: Status, Challenges, and Opportunities," Argonne, 2010.
- [4] J. Adolf, C. Balzer, A. Joedicke, and U. Schabla, "Shell LPG Study," Hamburg, 2015.
- [5] ETSAP, "Automotive LPG and Natural Gas Engines," © IEA ETSAP - *Technol. Br. T03*, no. April, pp. 1-5, 2010.
- [6] M. A. Ceviz and F. Yüksel, "Cyclic variations on LPG and gasoline-fuelled lean burn SI engine," *Renew. Energy*, vol. 31, pp. 1950-1960, 2006.
- [7] M. Gumus, "Effects of volumetric efficiency on the performance and emissions characteristics of a dual fueled (gasoline and LPG) spark ignition engine," *Fuel Process. Technol.*, vol. 92, no. 10, pp. 1862-1867, 2011.
- [8] A. Sürmen and M. Ihsan, "A comparative study of carburation and injection fuel supply methods in an LPG-fuelled SI engine," vol. 107, pp. 511-517, 2013.
- [9] B. Erkus, A. Surmen, M. I. Karamangil, R. Arslan, and C. Kaplan, "The effect of ignition timing on performance of LPG injected SI engine," *Energy Educ. Sci. Technol. Part a-Energy Sci. Res.*, vol. 28, no. 2, pp. 1199-1206, 2012.
- [10] B. Erkuş, M. I. Karamangil, and A. Sürmen, "Enhancing the heavy load performance of a gasoline engine converted for LPG use by modifying the ignition timings," *Appl. Therm. Eng.*, vol. 85, pp. 188-194, 2015.
- [11] A. Kaleli, M. A. Ceviz, and K. Erenturk, "Controlling spark timing for consecutive cycles to reduce the cyclic variations of SI engines," *Appl. Therm. Eng.*, vol. 87, pp. 624-632, 2015.
- [12] C. Gong, F. Wei, X. Si, and F. Liu, "Effects of injection timing of methanol and LPG proportion on cold start characteristics of SI methanol engine with LPG enriched port injection under cycle-by-cycle control," *Energy*, vol. 144, pp. 54-60, 2018.
- [13] S. M. Lawankar, "Comparative Study of Performance of LPG Fuelled Si Engine at Different Compression Ratio and Ignition Timing," *Int. J. Mech. Eng. Technol.*, vol. 3, no. 4, pp. 337-343, 2012.

- 
- [14] K. Ravi and E. Porpatham, "Effect of piston geometry on performance and emission characteristics of an LPG fuelled lean burn SI engine at full throttle condition," *Appl. Therm. Eng.*, vol. 110, pp. 1051–1060, 2017.
- [15] M. A. Ceviz, A. Kaleli, and E. Güner, "Controlling LPG temperature for SI engine applications," *Appl. Therm. Eng.*, vol. 82, pp. 298–305, 2015.
- [16] C. Çınar, F. Şahin, Ö. Can, and A. Uyumaz, "A comparison of performance and exhaust emissions with different valve lift profiles between gasoline and LPG fuels in a SI engine," *Appl. Therm. Eng.*, vol. 107, pp. 1261–1268, 2016.
- [17] World LPG Association, "Autogas Incentive Policies," Neuilly-sur-Seine, 2018.
- [18] World LPG Association, "Autogas Incentive Policies, 2017 Edition," Neuilly-sur-Seine, 2017.
- [19] V. Susanti, A. Hartanto, A. S. Ridwan, M. S. Hendri, R. Estiko, and A. Hapid, "Fuel Subsidy and Air Pollution Reduction by Policy Program Of Conversion Fuel CNG for Vehicles in West Java Province," *J. Mechatronics, Electr. Power, Veh. Technol.*, vol. 01, no. 2, pp. 43–52, 2010.
- [20] H. Budya and M. Yasir Arofat, "Providing cleaner energy access in Indonesia through the megaproject of kerosene conversion to LPG," *Energy Policy*, vol. 39, no. 12, pp. 7575–7586, Dec. 2011.
- [21] M. Setiyo, B. Waluyo, M. Husni, and D. W. Karmiadji, "Characteristics of 1500 CC LPG fueled engine at various of mixer venturi area applied on Tesla A-100 LPG vaporizer," *J. Teknol.*, pp. 43–49, 2016.